

No. 747,895.

PATENTED DEC. 22, 1903.

F. SCHUMACHER.  
ROLLER BEARING.

APPLICATION FILED OCT. 14, 1901.

NO MODEL.

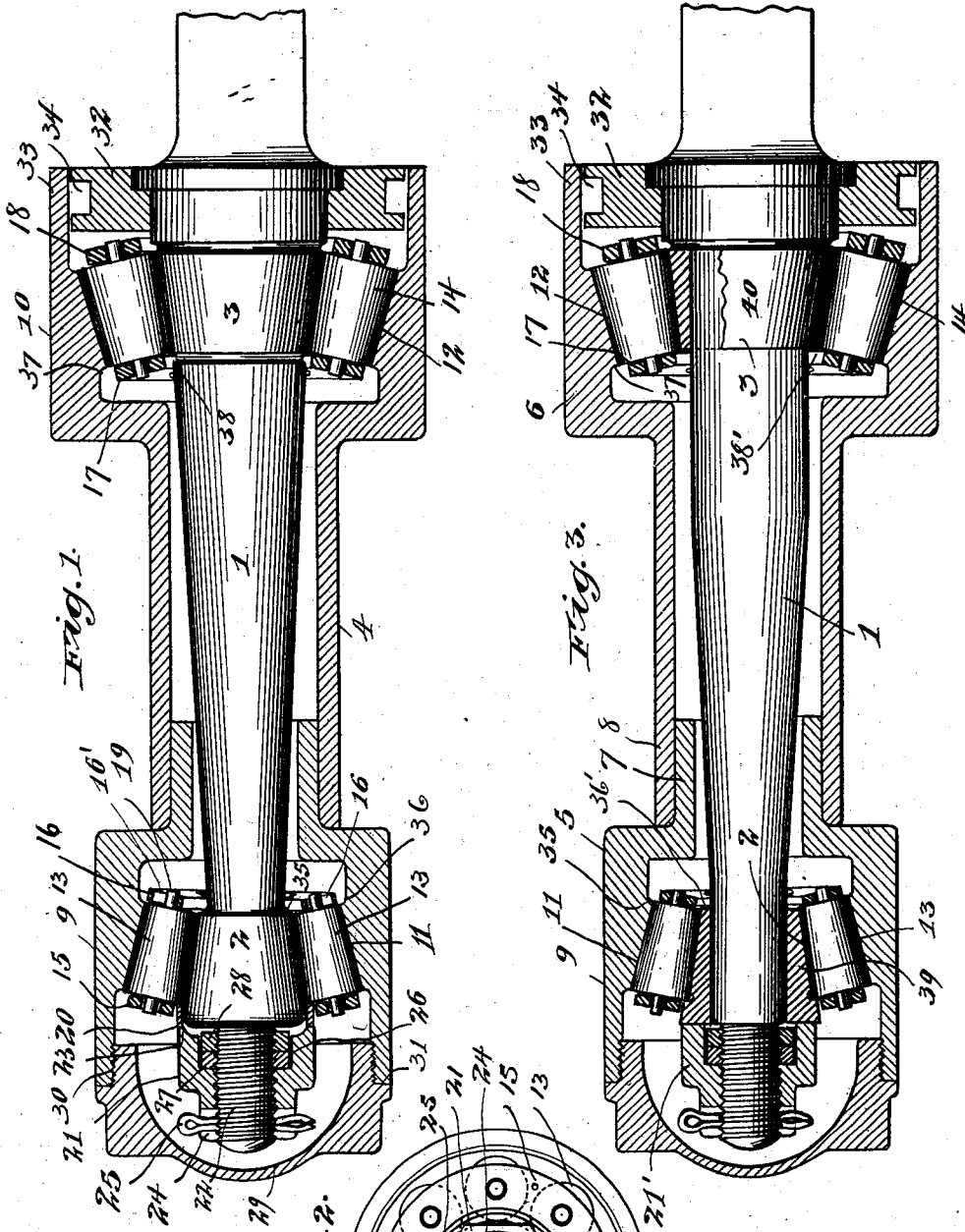

Witnesses,  
*J. S. Mann,*  
*A. N. Graves*

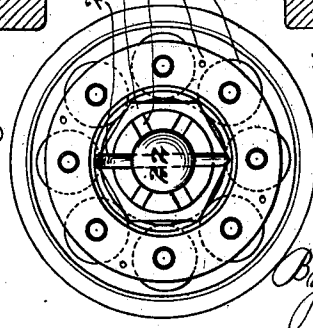

Inventor,  
*Frederick Schumacher,*  
 By *Offield Taylor Luthrum,*  
*Att'y.*

# UNITED STATES PATENT OFFICE.

FREDERICK SCHUMACHER, OF CHICAGO, ILLINOIS, ASSIGNOR, BY MESNE ASSIGNMENTS, TO MITCHELL F. MCCARTHY, OF CHICAGO, ILLINOIS.

## ROLLER-BEARING.

SPECIFICATION forming part of Letters Patent No. 747,895, dated December 22, 1903.

Application filed October 14, 1901. Serial No. 78,554. (No model.)

*To all whom it may concern:*

Be it known that I, FREDERICK SCHUMACHER, of the city of Chicago, county of Cook, and State of Illinois, have invented certain new and useful Improvements in Roller-Bearings, of which the following is a specification.

This invention relates to improvements in roller-bearings and refers more specifically to an improved roller-bearing adapted for vehicle-wheels and the like.

Among the salient objects of the invention are to provide a construction involving the use of a lesser number of parts and parts of simpler and more massive construction than have heretofore been combined; to provide a construction in which adjustment to compensate for wear at both ends of the axle or journal may be accomplished by the simple adjustment of a single adjusting annulus or nut; to provide a construction which enables the spindles or journals of vehicles which have originally been designed for the ordinary journal without ball or roller bearings to be reformed or shaped to embody in the present invention, thereby saving the expense of an entire new journal; to provide a construction which may be set or adjusted to a certain position and the journal thereafter removed and replaced without destroying or affecting the adjustment for wear; to provide a construction in which the entire adjustment may be effected by adjustment of a single part accessible at the outer end of the spindle, and in general to provide a simplified and improved construction of the character referred to.

To the above end the invention consists in the matters hereinafter described, and more particularly pointed out in the appended claims, and same will be readily understood from the following, reference being had to the accompanying drawings, in which—

Figure 1 is an axial sectional view of a preferred embodiment of my invention. Fig. 2 is an end view of the outer end of the spindle with the end-closing cap removed, and Fig. 3 is a view similar to Fig. 1 of a modified construction.

Referring to said figures, 1 designates the spindle or journal, which is provided adja-

cent to its end portions with oppositely-disposed conical bearing-surfaces or races 2 3, respectively, the outer end race 2 being substantially smaller than the inner race, as usual. In the preferred construction (shown in Fig. 1) both of the conical bearing-surfaces are formed directly upon the surface of the journal and the direction of taper of each is toward the other or toward the central portion of the length of the journal.

4 designates as a whole the journal-box, which is suitably constructed to inclose the spindle throughout its length, said journal-box in the preferred construction shown here- in consisting of two members 5 and 6, respectively, having contracted central portions 7 and 8, which telescope and fit together, as indicated clearly in drawings, and enlarged end portions 9 and 10, respectively, which are chambered to receive the bearing portions of the journal. Between the bearing-surfaces 2 and 3 of the journal and the correspondingly-inclined bearing portions 11 and 12, respectively, of the box are interposed conical rollers 13 and 14, these rollers being arranged, as usual, in series encircling the journal and being confined and held at suitable intervals apart by means of caging-rings 15, 16, 17, and 18, which are engaged with the trunnions 19 of the individual rollers in the usual manner. In order to permit the outer set of rollers to be adjusted over the end of the journal after they have been assembled or connected by means of the caging-rings, the inner ring 16 is formed with radially-disposed slots 16' to receive the trunnions 19 of rollers, thereby enabling the smaller ends of said rollers to move outwardly or expand, so as to pass over the largest portion of that end of the journal. Inasmuch as these slots 16' are of a width practically equal to the diameter of the trunnions, the caging-ring 16 obviously serves to confine the rollers accurately in position circumferentially, notwithstanding their freedom to move outwardly. Owing to the fact that the race portion of the inner end of the journal is larger than the largest part of the outer end of the latter, the set of rings belonging to that end may obviously be adjusted to position without any special provision.

Describing now the means whereby the op-

erative parts of the journal are locked together and in an adjusted position, 20 designates an adjusting-ring constructed to fit upon the outer end of the journal in position for its inner edge to contact against the larger ends of the rollers 13 thereof, this ring being of sufficient width to project substantially beyond the bearing portion at its edge opposite that which engages the rollers.

21 designates an adjusting-nut threaded upon the reduced and threaded extension 22 of the journal and having its inner edge 23 arranged to bear against the edge of the adjusting-ring 20. The outer end of that portion of the nut which engages the threaded extension 22 is provided with a plurality of diametrically-disposed slots or grooves 24, and the end of the extension 22 is apertured to receive a key or cotter 25, inserted through any given one of said slots and the end of the extension, the depth of said slots being considerable, so that the nut may be adjusted back and forth and still be locked in adjusted position by the cotter in a familiar manner. In order to provide means whereby the bearing may be taken apart without loosening the adjustment, the adjusting-nut 21 is made hollow or provided in its inner face with a recess 26, and within this recess are threaded upon the extension 22 a pair of lock-nuts 27 and 28, respectively. After placing the lock-nuts 28 and 27 and the adjusting-nut 21 upon the extension 22 in the order named the position of the adjusting-nut is determined by setting the outer lock-nut 27 at different points on said extension until the desired position of adjustment is obtained, then by locking it in such position by means of the lock-nut 28, it being understood, of course, that it is necessary to turn the adjusting-nut on and off until the desired position of adjustment is determined. It will thus be seen that the distance to which the adjusting-nut 21 may be advanced will be fixed, and therefore the adjustment of the bearing as a whole. It will be further obvious that the removal of the adjusting-nut 21 for the purpose of removing the journal will not disturb the lock-nuts 27 and 28, and the adjustment of the bearing will therefore be retained, since the adjusting-nut will be returned to position and screwed up against nut 27.

In order to close the outer end of the journal, the latter is provided with an end-closing cap 29, provided with a reduced and threaded portion 30, which fits within the correspondingly-threaded outer end of the journal-box, said cap being provided with an annular shoulder 31, which abuts against the end margin of the box. The opposite end of the journal is provided with a dust-excluding ring 32, over the periphery of which the end portion 33 of the journal-box fits closely, a circumferential groove 34 being formed in the dust-ring 32 to form a trap which aids in preventing access of dust and other matter to the bearings.

It is to be particularly noted that each of the conical bearing-surfaces upon which the sets of rollers act, both of the journal and of the journal-box, are so formed or constructed as to avoid being worn into grooves or uneven surfaces—that is to say, those portions of said surfaces which are engaged by the smaller ends of the bearings terminate at their edges at recesses or retreated portions, as indicated at 35, 36, 37, and 38, so that as the rollers are advanced to compensate for wear they will simply project or overhang said rollers more or less, but will not encounter ribs which would be formed by the wear of the rollers upon smooth surfaces extending beyond the ends of the rollers. This is a feature of much importance, since it has been found in practice that rollers wearing upon smooth bearing-surfaces tend to cut away such surfaces and form, as it were, grooves within which they travel, and upon adjustment to compensate for wear thus incurred only the extreme ends of the rollers have bearing with the races, for the reason that the rollers are advanced so as to rest at their advanced ends upon the unworn and relatively higher surfaces. This obviously results in a defective bearing and an undue increase of friction, as well as an unnatural and unnecessary strain upon the rollers. By making the journal in the form described these objectionable results are entirely avoided, and in this connection it may be noted that it is entirely immaterial if the wearing-surfaces at the larger ends of the rollers become uneven, since the rollers will always be advanced farther and farther by adjustment to compensate for wear.

The operation of the device is entirely obvious from the foregoing description and need not, therefore, be detailed.

In Fig. 3 I have shown a modification which in its general construction is substantially like that hereinbefore described; but in this instance the wearing-surfaces or roller-race portions of the journal are formed upon separate wearing-rings 39 and 40, which are fitted upon the journal in proper positions. The provision of a removable wearing-ring at the outer end of the journal obviates the necessity of providing the radially-grooved caging-ring, since the wearing-ring 39 may be adjusted to position after the rollers have been inserted. In this modification also the wearing-ring 39 is adjusted forwardly or toward the smaller end of its rollers to compensate for wear instead of the set of rollers themselves being advanced, it being obvious that substantially the same result of taking by wear will be arrived at. In this instance, therefore, the adjusting-nut 21' is constructed to fit directly against the end of the bearing-ring 39, and thus serves to determine the position of the latter. In other respects the bearing is practically identical with that previously described, it being noted that the annular recesses or retreats 36' and 38' are formed at

the inner edges of the bearing-rings 39 and 40 by the difference in diameter between the latter and the portions of the spindle upon which they rest.

5 While I have herein described what I deem to be preferred embodiments of my invention, yet it will be obvious from the foregoing that the details thereof may be modified to some extent without departing from the spirit of  
10 the invention, and I do not, therefore, wish to be limited to these details, except to the extent that they are made the subject of specific claims.

I claim as my invention—

15 1. In a roller-bearing, the combination of a journal and journal-box, each having conical roller-engaging surfaces, interposed rollers and means for effecting the longitudinal relative adjustment of the rollers, said roller-engaging surfaces being raised above the immediately adjacent surfaces of the bearing  
20 members at those sides of said surfaces toward which the rollers are advanced relatively by adjustment, whereby the bringing  
25 of the rollers into bearing engagement with unworn surfaces by adjustment is avoided.

2. In a roller-bearing, the combination of a journal provided at axially-separated points with conical bearing-surfaces which taper toward each other, a journal-box inclosing said  
30 journal and provided with correspondingly-tapered roller-races, series of conical rollers interposed between said journal and journal-box and means for effecting the relative ad-  
35 vance of said conical rollers in the direction of their smaller ends, those sides of the annular races toward which the rollers are advanced relatively being raised above the immediately-adjointing surfaces of the bearing  
40 members, as and for the purpose set forth.

3. In a roller-bearing for vehicle-wheel journals, the combination of a spindle provided at its outer end with an inwardly-tapering integral roller-race portion, a journal-  
45 box inclosing said race portion and provided

with a correspondingly-tapered opposed bearing-surface, a set of conical rollers interposed between said spindle and journal-box, a hollow adjusting-nut threaded upon an extension  
50 of the spindle extending beyond said bearing portion and arranged to confine said rollers against longitudinal outward movement, and a pair of check-nuts threaded upon the said spindle extension within said hollow  
55 adjusting-nut, as and for the purpose set forth.

4. In a roller-bearing for vehicle-wheel journals, the combination of a spindle provided at its outer end with an inwardly-tapering integral roller-race portion, a journal-  
60 box inclosing said race portion provided with a correspondingly-tapered opposed bearing-surface, a set of conical rollers interposed between said journal-box and spindle, a pair of caging-rings engaging and confining the opposite ends of said rollers, the inner caging-  
65 rings being provided with radially-elongated slots for the reception of the roller-trunnions and an adjusting-nut mounted upon the outer end of the spindle and arranged to confine  
70 the set of rollers against outward movement.

5. In a roller-bearing the combination of a spindle provided with a conical or tapering roller-race surface, a journal-box surrounding said race, a set of conical rollers inter-  
75 posed between the journal-box and race, caging devices engaged with said rollers, means at the larger end of said conical race portion of the spindle adapted to abut against the  
80 larger ends of said rollers to confine the same against axial movement in the direction of their said larger ends, an adjusting-nut adapted to engage said means, and adjustably-fixed means for marking the different positions of adjustment of said nut.

FREDERICK SCHUMACHER.

Witnesses:

FREDERICK C. GOODWIN,  
ALBERT H. GRAVES.