



US00D701475S

(12) **United States Design Patent**  
**Matsumoto et al.**

(10) **Patent No.:** **US D701,475 S**

(45) **Date of Patent:** **\*\* \*Mar. 25, 2014**

(54) **AUTOMOBILE AND/OR TOY REPLICA THEREOF**

(75) Inventors: **Kengo Matsumoto**, Nagoya (JP); **Shinichi Hiranaka**, Miyoshi (JP); **Shin Miyata**, Nissin (JP); **Satoru Sugimoto**, Toyota (JP)

(73) Assignee: **Toyota Jidosha Kabushiki Kaisha (JP)**

(\*) Notice: This patent is subject to a terminal disclaimer.

(\*\*) Term: **14 Years**

(21) Appl. No.: **29/431,238**

(22) Filed: **Sep. 5, 2012**

**Related U.S. Application Data**

(62) Division of application No. 29/388,890, filed on Apr. 4, 2011, now Pat. No. Des. 669,406.

(30) **Foreign Application Priority Data**

|              |      |       |             |
|--------------|------|-------|-------------|
| Jan. 7, 2011 | (JP) | ..... | 2011-000242 |
| Jan. 7, 2011 | (JP) | ..... | 2011-000243 |
| Jan. 7, 2011 | (JP) | ..... | 2011-000244 |
| Jan. 7, 2011 | (JP) | ..... | 2011-000245 |
| Jan. 7, 2011 | (JP) | ..... | 2011-000246 |

(51) **LOC (10) Cl.** ..... **12-16**

(52) **U.S. Cl.**  
USPC ..... **D12/169**

(58) **Field of Classification Search**  
USPC ..... D12/163, 196, 171, 169, 216, 90-92, D12/86; 180/68.1, 68.6; 296/193.11  
See application file for complete search history.

(56) **References Cited**

**U.S. PATENT DOCUMENTS**

|            |        |                 |
|------------|--------|-----------------|
| D501,435 S | 2/2005 | Hosoda et al.   |
| D536,284 S | 2/2007 | Nakamura et al. |

|                 |         |                      |         |
|-----------------|---------|----------------------|---------|
| D538,716 S      | 3/2007  | Hogios               |         |
| D539,196 S      | 3/2007  | Pfeiffer             |         |
| D539,707 S      | 4/2007  | Golden et al.        |         |
| D578,444 S      | 10/2008 | Kuo                  |         |
| D587,636 S      | 3/2009  | Kanno et al.         |         |
| D592,560 S      | 5/2009  | Bauer et al.         |         |
| D596,088 S      | 7/2009  | Camacho et al.       |         |
| D605,989 S      | 12/2009 | Leng et al.          |         |
| D619,514 S *    | 7/2010  | Syouji et al. ....   | D12/169 |
| D620,850 S *    | 8/2010  | Sakae et al. ....    | D12/169 |
| D637,533 S *    | 5/2011  | Miyazawa et al. .... | D12/169 |
| D640,614 S *    | 6/2011  | Kumai et al. ....    | D12/169 |
| D640,958 S *    | 7/2011  | Yokoi et al. ....    | D12/169 |
| 2006/0119115 A1 | 6/2006  | Filip et al.         |         |

**OTHER PUBLICATIONS**

2009 Audi A6, www.netcarshow.com, posted by NetCarShow at least as early as 2009.

2011 Lexus CT200h, www.netcarshow.com, publicly known at least as early as Mar. 2010.

\* cited by examiner

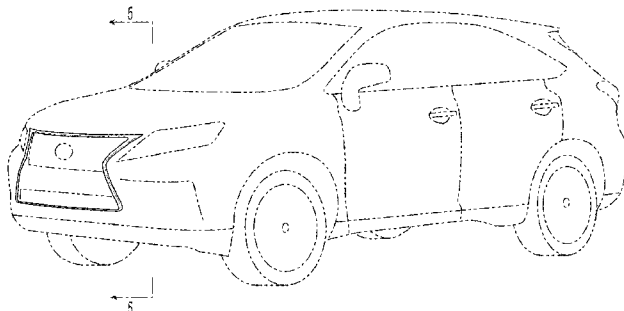
*Primary Examiner* — Melody Brown  
(74) *Attorney, Agent, or Firm* — SAIDMAN DesignLaw Group

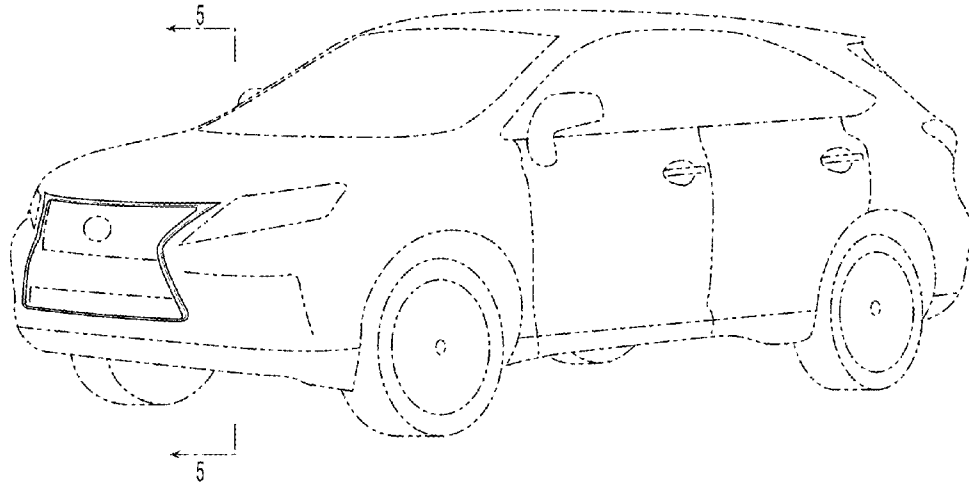
(57) **CLAIM**  
The ornamental design for an automobile and/or toy replica thereof, as shown and described.

**DESCRIPTION**

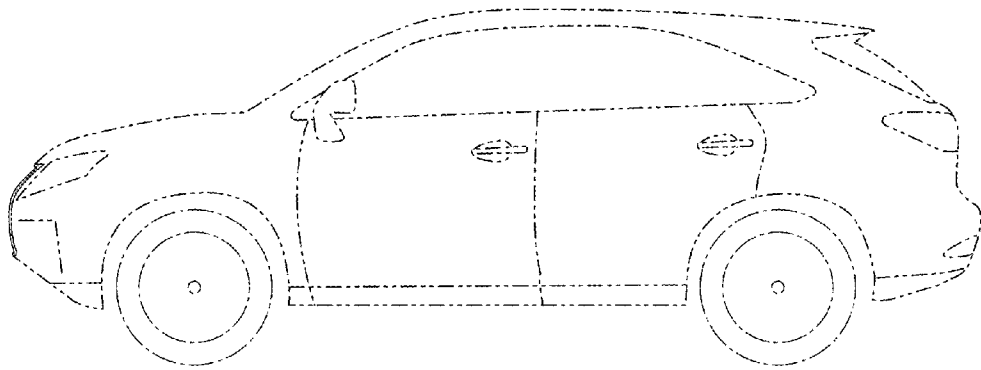
FIG. 1 is a perspective view of an automobile and/or toy replica thereof showing our new design;  
FIG. 2 is a left side view thereof, the right side view being a mirror image;  
FIG. 3 is a top view thereof;  
FIG. 4 is a front view thereof;  
FIG. 5 is an enlarged view showing a portion of FIG. 1 defined by line 5-5; and,  
FIG. 6 is an enlarged view showing a portion of FIG. 4 defined by lines 6-6.  
The broken lines illustrate environmental structure and form no part of the claimed design.

**1 Claim, 4 Drawing Sheets**

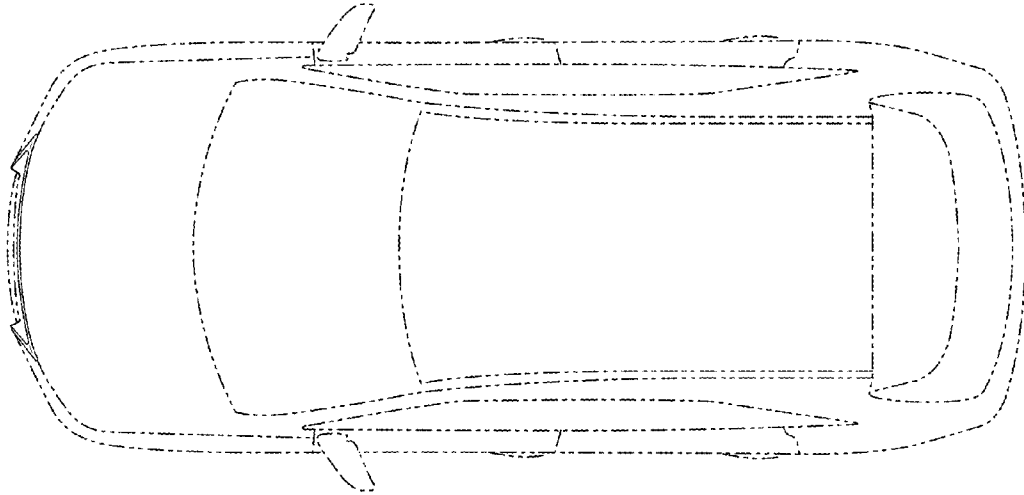




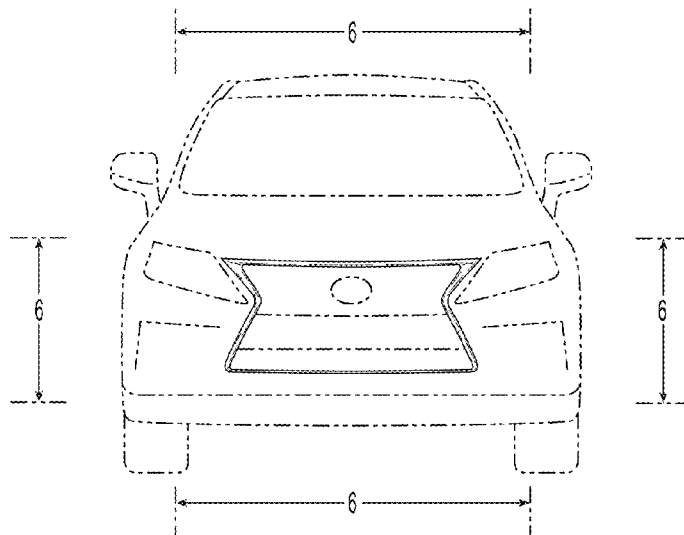
**Fig. 1**



**Fig. 2**



**Fig. 3**



**Fig. 4**

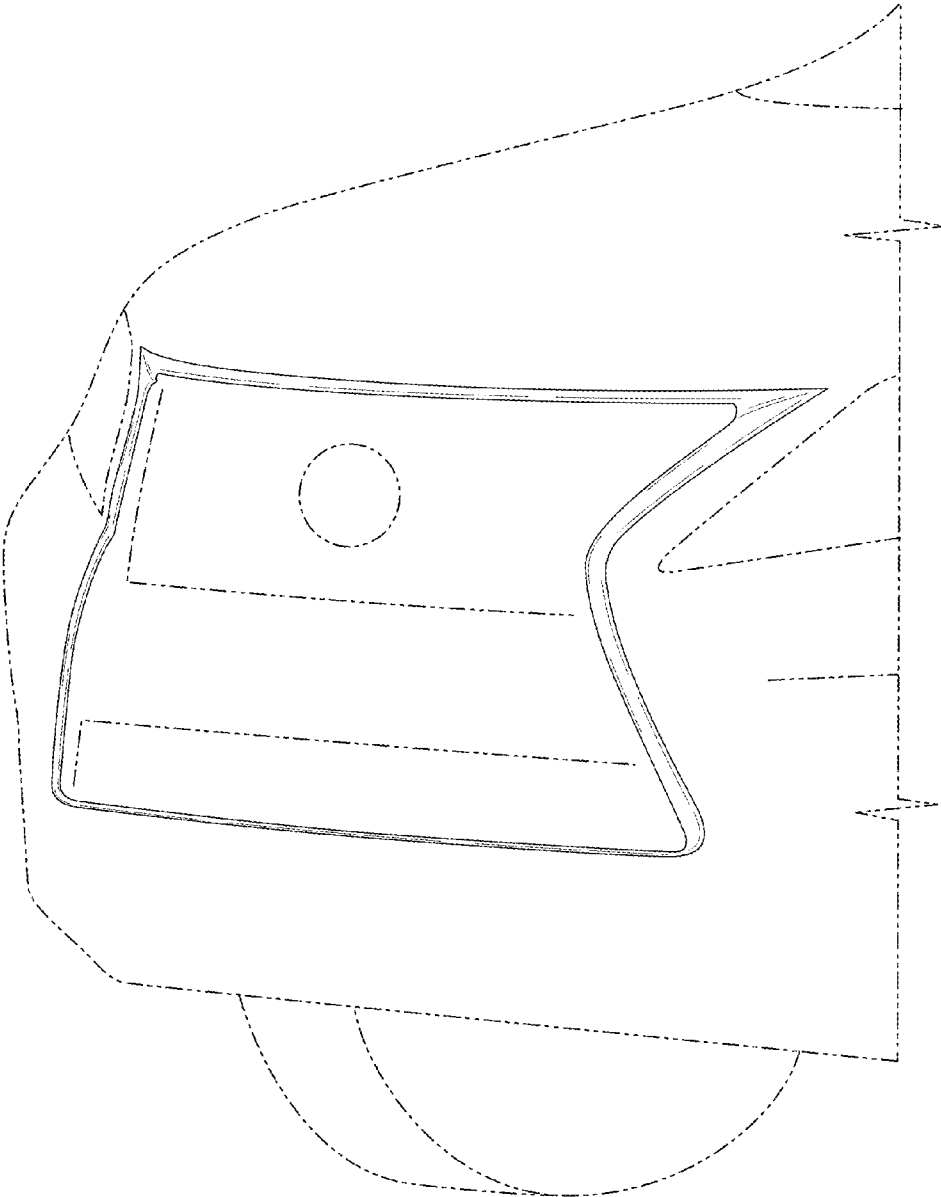
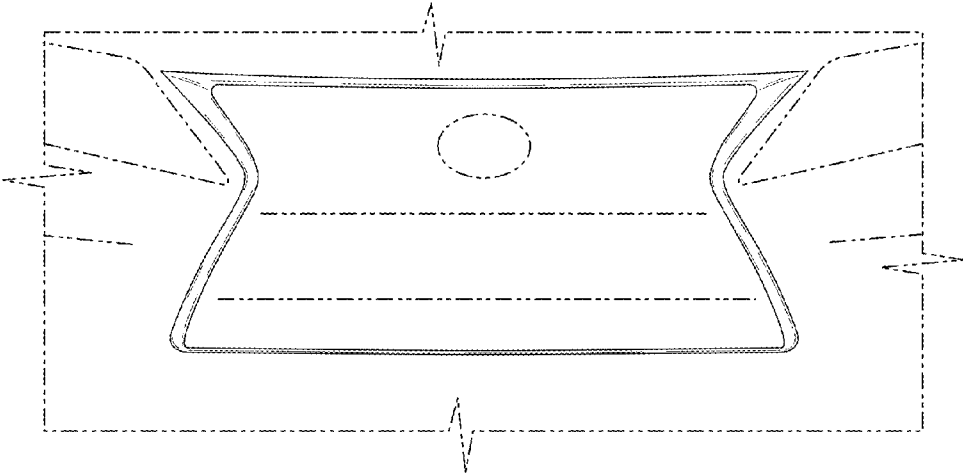


Fig. 5



**Fig. 6**