

No. 765,229.

PATENTED JULY 19, 1904.

S. J. DUNLOP.  
GAGE COCK.

APPLICATION FILED MAR. 22, 1904.

NO MODEL.

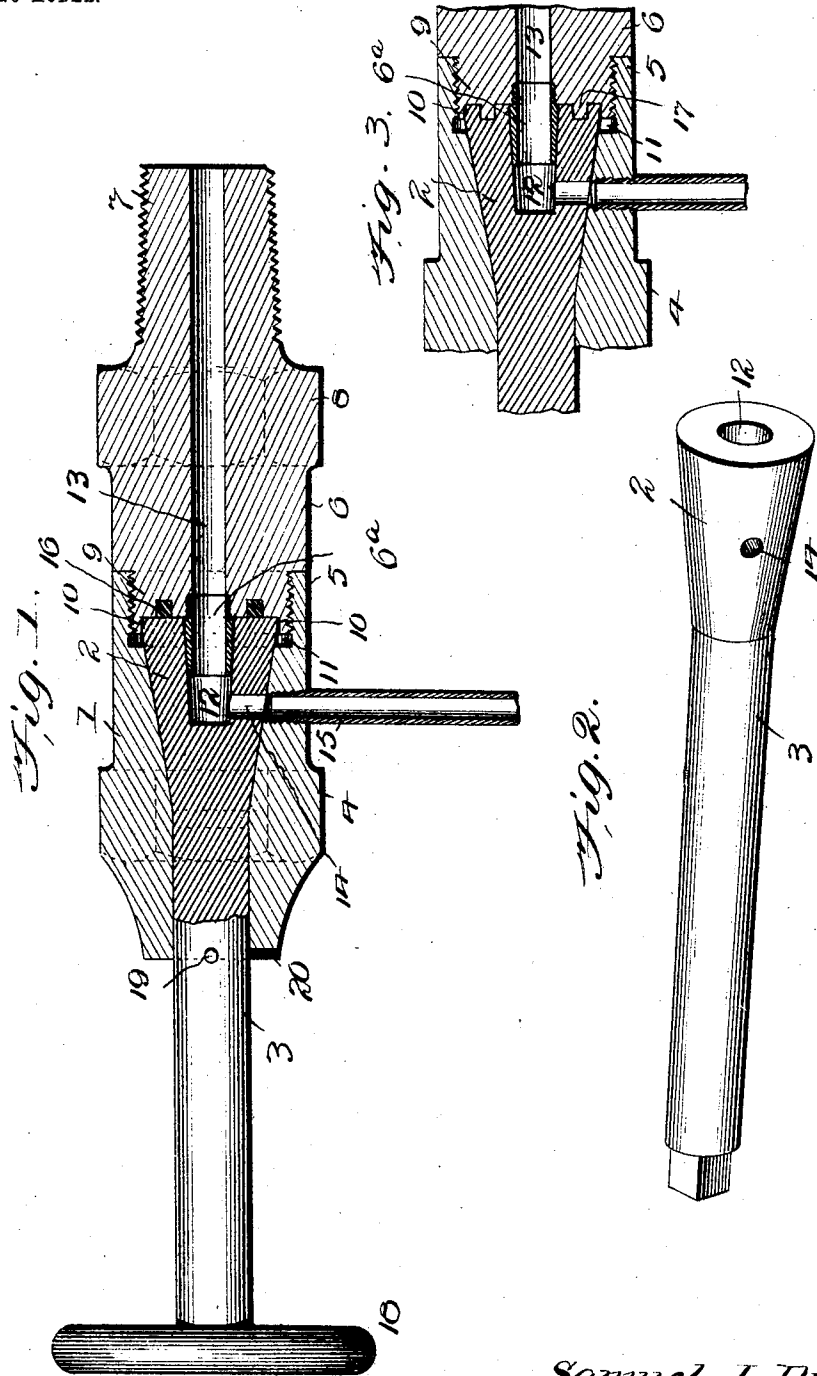

Witnesses.  
*F. C. Barry.*  
*J. C. Brillham.*

Inventor  
*Samuel J. Dunlop.*  
 3811  
*W. J. Fitzgerald*  
 Attorney

# UNITED STATES PATENT OFFICE.

SAMUEL J. DUNLOP, OF NEWARK, OHIO, ASSIGNOR OF ONE-HALF TO  
WILLIAM M. GLENN, OF NEWARK, OHIO.

## GAGE-COCK.

**SPECIFICATION** forming part of Letters Patent No. 765,229, dated July 19, 1904.

Application filed March 22, 1904. Serial No. 199,383. (No model.)

*To all whom it may concern:*

Be it known that I, SAMUEL J. DUNLOP, a citizen of the United States, residing at Newark, in the county of Licking and State of Ohio, have invented certain new and useful Improvements in Gage-Cocks; and I do hereby declare the following to be a full, clear, and exact description of the invention, such as will enable others skilled in the art to which it appertains to make and use the same.

My invention relates to valves or gage-cocks; and it consists of certain novel features of combination and construction of parts, the preferred form whereof will be hereinafter clearly set forth, and pointed out in the claims.

The prime object of my invention, among others, is to provide a valve or gage-cock which will be found thoroughly reliable in the performance of its office and which at the same time will possess great capacity to resist wear and consequent leakage.

A further object of my invention is to provide means to compensate for the wear incident to moving one metal part upon another.

Another object is to convey the steam, water, or other liquid through the valve on the most direct or shortest line without in any wise coming in contact with the valve and the seat thereof.

Other objects and advantages will be hereinafter made clearly apparent, reference being had to the accompanying drawings, which are made a part of this application, and in which—

Figure 1 shows a longitudinal central section of my valve as applied to an ordinary gage-cock. Fig. 2 is a perspective view showing the valve removed from its seat. Fig. 3 is a sectional view of the valve and its seat, showing another form of materialization of my invention.

The various details and cooperating accessories will for convenience be designated by numerals, the same numeral applying to a similar part throughout the several views.

While I shall illustrate my invention as applied to use upon an ordinary gage-cock for steam-engines, it will be understood that the essential features of my invention may be

utilized in a great variety of ways, inasmuch as my form of valve will be found efficient and valuable not only as a steam gage-cock, but as a valve for the control of steam, water, oil, or gas, inasmuch as my valve will be found particularly advantageous and efficient for the control of all liquids or fluids, especially those charged with gritty substances, as oil, water, &c. It therefore follows that my form of valve will be especially desirable when used as a blow-off valve for discharging steam and grit carried thereby incident to the cleaning of a boiler. The great efficiency of my form of valve is due to the fact that the valve proper never moves off of its seat, but always remains in close engagement therewith, being simply rotated upon its seat in order to bring a port leading from the interior of the valve into registration with a port in the casing.

Referring in detail to the drawings, 1 designates the main or body portion of my valve, which is provided with an interior bore the major portion whereof is conical in form, while the outer end is cylindrical. The conical part of the bore is coincident in size with the conical body portion 2 of my valve proper, while the stem 3, made integral with my valve, is cylindrical in form, and therefore snugly fits in the cylindrical bore in the outer end of the body portion 1, a suitable wrench-surface 4 being formed upon the body portion 1 to facilitate the control thereof, as will be hereinafter set forth.

The body portion 1 of my valve is provided with an internally-threaded valve or extension 5, adapted to receive the threaded inner end of the anchoring portion or extension 6 of my valve, the extreme end of said extension being slightly conical and threaded, as indicated by the numeral 7, said threaded terminal being designed to be seated in a threaded hole in the boiler or other point where the valve is to be located, a wrench-face 8 being formed to facilitate the seating thereof. The inner end of the anchoring member 6 is reduced in size, as indicated by the numeral 9, and this reduced portion being threaded fits securely within the flange 5, as before stated, a suitable annular recess being formed in the

extreme inner end of the extension 9 to receive the end of the valve 2. It will thus be observed that the valve 2 is surrounded by an exteriorly-threaded flange, as designated by the numeral 10. I also provide the annular groove or recess 11 surrounding the inner end of the conical valve 2, said recess being desirable as a seat for packing if deemed necessary.

It will be observed by reference to the drawings that the conical valve-body 2 is provided with a bore 12, which registers with the bore 13 in the anchoring member 6. It will be furthermore seen that I have provided a discharging-port 14, extending through the wall of the valve and communicating with the bore 12 and adapted to be brought into or out of registration with a corresponding bore or exit-port in the casing or body portion 1, said part preferably having threaded therein the discharging-nipple 15.

The anchoring extension 6 is provided with a nipple or extension 6<sup>a</sup>, which may be formed integral with the extension 6 or may be threaded into the end of the bore 13. This device is provided with a bore of substantially the same size as the bore 13 and is designed to form a continuation thereof. The outer periphery of the extension 6<sup>a</sup> may be conical or cylindrical and in all cases is designed to snugly fit within the bore 12.

From the foregoing description it is therefore obvious that my valve may be instantly opened or closed by simply turning the valve 2 upon its seat, and since said valve always remains squarely in engagement with its seat it will be impossible for sediment, grit, or the like carried by the steam, water, or other liquid passing through the valve to enter between the seat and valve, thereby insuring that the life and usefulness of the valve will be long preserved.

Obviously that class of valves or gage-cocks wherein the valve proper rises off of its seat to permit the escape of the steam or the like around it will cause more or less deposit of sediment and grit between the valve and seat, and thus destroy the prepared surfaces thereof and incidentally cause a leakage, it being found in practice that a gage-cock of ordinary construction will very soon begin to leak after the same has been used but a comparatively short time, whereas in the use of my form of valve the pressure of the steam within the boiler will naturally tend to hold the valve truly upon its seat, when a simple rotation or partial rotation of the valve will cause the registration of the discharging-ports in the valve and casing, thereby enabling the valve to be instantly opened and as quickly closed.

If it should be deemed desirable, a suitable gasket-seat, as an annular groove, may be provided in the inner end of the extension 9 and the gasket 16 located therein, said gasket be-

ing designed to bear directly against the inner end of the conical valve-body 2, as clearly shown in Fig. 1.

In some instances the gasket-seat in the end of the extension 9 may be replaced with an annular rib or extension 17, designed to fit a corresponding annular recess provided in the end of the valve, and it is therefore obvious that in case the valve and its seat should become worn the inner end of the valve will withdraw from engagement with the face of the extension 9; but said annular rib or extension 17 will guard against the possibility of the escape of steam or the like between said parts. It is thought, however, that both the extension or rib 17 and the gasket 16 may be entirely dispensed with and reliance placed solely upon the ground tightly-fitting faces of the valve and valve-seat for the exclusion or escape of steam or the like, and I therefore reserve the right to make my valve or gage-cock with or without said rib or gasket-seat, as I may find most desirable in practice.

The valve-stem 3 being properly shaped at its outer end is designed to receive a handle or controlling-wheel 18, whereby the valve may be readily opened or closed, as desired, a suitable stop-pin 19 being located in the valve-stem and designed to engage a shoulder 20, formed in the outer end of the body portion 1, when the valve is turned open or closed.

It will thus be seen that I have provided a very simple form of valve or gage-cock which will be found useful for a great variety of purposes not alone for the control of steam, but, as before stated, it will be found especially useful upon water-mains, as for opening and closing hydrants in case of fire, and also for use upon oil-pumps, where a large amount of grit, sand, or the like must pass through the valve. Since, therefore, the steam or the like controlled by my valve does not come in contact with the meeting surfaces of the valve and valve-seat, the wear upon the valve is almost wholly eliminated.

While I have described the preferred combination and construction of parts deemed necessary in materializing my invention, I desire to comprehend in this application all substantial equivalents and substitutes that may be regarded as falling fairly within the scope of my invention.

Having thus fully described the construction and manner of using my improved valve or gage-cock, further description is deemed unnecessary.

What I claim as new, and desire to secure by Letters Patent, is—

1. In a gage-cock, the combination with a body having a central bore, conical a portion of its length, and an anchoring member having a seat thereon and bore throughout its length, of a conical valve to fit said bore in the body portion, said valve having a hollow interior,

said valve and body portion having exit-ports adapted to register, and a nipple carried by said anchoring member adapted to take into and fit the interior opening in said valve whereby grit, &c., will be kept from the valve-seat, as set forth.

2. In a gage-cock, the combination with a body portion and an anchoring member having a valve-seat, of a valve having a hollow interior adapted to register with the bore in the anchoring member, of a nipple having a bore, said nipple being secured to said anchoring member and extending into the valve, said valve and body portion having suitable ports adapted to register when desired, as set forth.

3. The herein-described gage-cock, comprising a body portion, having a central bore, a valve located therein, an anchoring member having a seat for said valve and projections carried by said anchoring member adapted to take into suitable openings in said valve where-

by the leakage of steam between said valve and its seat will be prevented, as set forth.

4. A gage-cock, comprising a body portion having a central bore, a valve fitting in said bore and having a hollow interior, an anchoring member having a valve-seat and a bore throughout its entire length, and a tubular extension adapted to take into and register with the hollow interior of said valve whereby the bore in said anchoring member will be elongated and the steam-exit point carried beyond the junction of said valve and its seat, substantially as set forth.

In testimony whereof I have signed my name to this specification in the presence of two subscribing witnesses.

SAMUEL J. DUNLOP.

Witnesses:

WM. M. GLENN,  
NELLIE DUNLOP.