

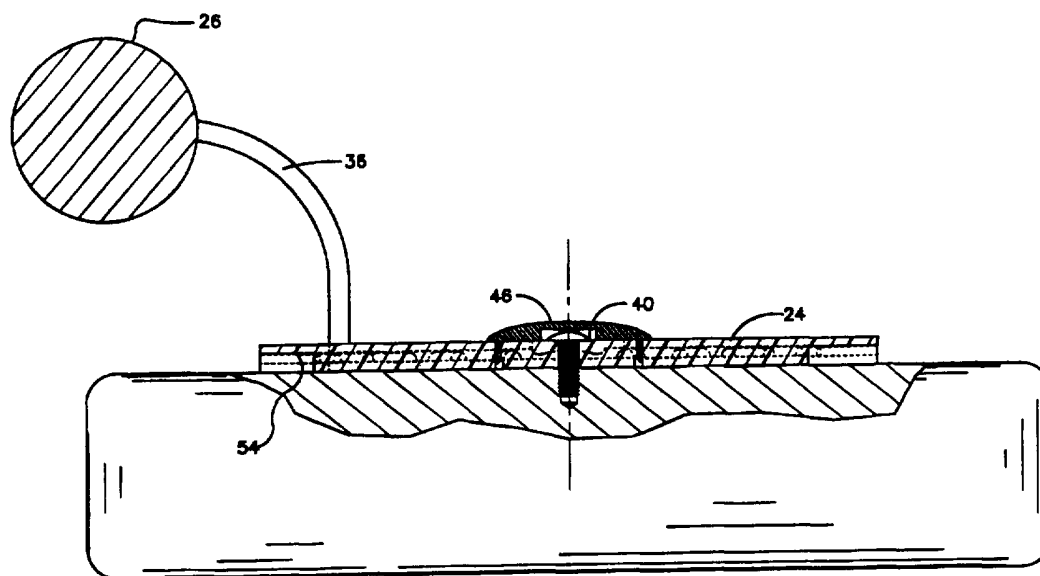

INTERNATIONAL APPLICATION PUBLISHED UNDER THE PATENT COOPERATION TREATY (PCT)

(51) International Patent Classification ⁶ : G09G 5/00	A1	(11) International Publication Number: WO 96/16396 (43) International Publication Date: 30 May 1996 (30.05.96)
<p>(21) International Application Number: PCT/US95/14408</p> <p>(22) International Filing Date: 16 November 1995 (16.11.95)</p> <p>(30) Priority Data: 08/341,429 17 November 1994 (17.11.94) US</p> <p>(71) Applicant: TELETRANSACTION, INC. [US/US]; 3330 West Market Street, Akron, OH 44334 (US).</p> <p>(72) Inventors: MYERSON, Robert, F.; Captiva Drive, Captiva Island, FL 33924 (US). CHUANG, Yung-Fu; 3252 Hardwood Hollow, Medina, OH 44256 (US). KOCHIS, Gary; 2663 Corry Circle N.W., Uniontown, OH 44685 (US). EMBREE, Donald, M.; 9105 Bietchley Avenue N.W., North Canton, OH 44720 (US).</p> <p>(74) Agent: FISHER, Thomas, E.; Watts, Hoffmann, Fisher & Heinke Co., L.P.A., P.O. Box 99839, Cleveland, OH 44199-0839 (US).</p>	<p>(81) Designated States: AU, CA, JP, MX, European patent (AT, BE, CH, DE, DK, ES, FR, GB, GR, IE, IT, LU, MC, NL, PT, SE).</p> <p>Published <i>With international search report.</i></p>	

(54) Title: INTERACTIVE DISPLAY USER INTERFACE COMPUTER AND METHOD



(57) Abstract

A hand-held portable computer (10) is disclosed. The computer includes a housing (12) at least partially enclosing computer electronics, a visible display screen (14) supported by the computer housing (12) and a handle assembly (20) connected to the computer housing (12). The handle assembly (20) includes a handle support (22), a support retainer (24) affixed to the housing (12) at a location opposite the screen (14) and a handle (26) supported by the handle support. The support retainer (24) adjustably connects the handle support (22) to the computer housing (12). In the preferred embodiment, the handle support (22) is rotatably adjustable with respect to the computer housing (12). The handle support (22) includes an annular ring having a plurality of indentations on one surface and the support retainer (24) includes a detent which engages a selected one of the indentations to secure the handle support in a desired rotational orientation.

FOR THE PURPOSES OF INFORMATION ONLY

Codes used to identify States party to the PCT on the front pages of pamphlets publishing international applications under the PCT.

AT	Austria	GB	United Kingdom	MR	Mauritania
AU	Australia	GE	Georgia	MW	Malawi
BB	Barbados	GN	Guinea	NE	Niger
BE	Belgium	GR	Greece	NL	Netherlands
BF	Burkina Faso	HU	Hungary	NO	Norway
BG	Bulgaria	IE	Ireland	NZ	New Zealand
BJ	Benin	IT	Italy	PL	Poland
BR	Brazil	JP	Japan	PT	Portugal
BY	Belarus	KE	Kenya	RO	Romania
CA	Canada	KG	Kyrgystan	RU	Russian Federation
CF	Central African Republic	KP	Democratic People's Republic of Korea	SD	Sudan
CG	Congo	KR	Republic of Korea	SE	Sweden
CH	Switzerland	KZ	Kazakhstan	SI	Slovenia
CI	Côte d'Ivoire	LI	Liechtenstein	SK	Slovakia
CM	Cameroon	LK	Sri Lanka	SN	Senegal
CN	China	LU	Luxembourg	TD	Chad
CS	Czechoslovakia	LV	Larvia	TG	Togo
CZ	Czech Republic	MC	Monaco	TJ	Tajikistan
DE	Germany	MD	Republic of Moldova	TT	Trinidad and Tobago
DK	Denmark	MG	Madagascar	UA	Ukraine
ES	Spain	ML	Mali	US	United States of America
FI	Finland	MN	Mongolia	UZ	Uzbekistan
FR	France			VN	Viet Nam
GA	Gabon				

INTERACTIVE DISPLAY USER INTERFACE COMPUTER AND METHOD

Cross-Reference to Related Application

5 The present application is a continuation-in-part of U.S. Application Serial No. 08/268,806 to Meyerson et al. entitled "Configurable Electronic Work Slate Unit" filed on June 30, 1994.

Field of the Invention

10 This invention relates to a hand-held portable computer and, more particularly, to a hand-held computer with an adjustable handle.

Background Art

15 Hand-held portable computers are used by a variety of enterprises including manufacturing firms, department, grocery and drug stores, transportation companies, package delivery services, insurance firms and utility companies. Hand-held computers are advantageously employed to facilitate such diverse business functions as inventory control, production scheduling and expediting, billing and both package route tracking.

20 Hand-held computers, including pen computers and touch screen computers, are gaining popularity in the hand-held computer market. A pen computer is a portable computer including a housing enclosing a microprocessor and associated circuitry and an interactive visible display screen, often referred to as an electronic workslate. Instead of using a keyboard to enter data and initiate processing routines, a pen computer utilizes either a cordless electromagnetic pen
25 or an electromagnetic pen tethered to the housing to interact with the microprocessor. By appropriately touching the display screen with the pen, a user may input data and access stored data, boot up an operating system, change screen displays or menus, select and run programs from a set of application and utility programs stored in computer memory and enter processing or query
30 commands. The pen computer also includes a transceiver for transmitting and receiving data via radio frequency signals and input/output ports to interface with various devices.

A touch screen computer is similar to a pen computer but, instead of using an electromagnetic pen to interface with the computer, a touch sensitive display screen is provided and the user interfaces with the computer by appropriately touching areas of the display screen with his or her finger to execute commands, enter data, respond to prompts, etc.

As user mobility is a key advantage of hand-held computers, such computers will often be operated by a user who is standing or walking, e.g., a user entering inventory data into the computer while walking through a warehouse. To use a pen computer in a standing position, the electronic pen is grasped in the user's writing hand while the housing is supported in the other hand by grasping an edge of the housing with the hand such that the user's fingers extend over a bottom surface of the housing and a thumb extends over a portion of an upper surface of the computer housing. Alternately, the computer may be supported by the user's forearm. In this position, a lower surface of the computer rests on the forearm and palm and the user grips the computer by curling his or her fingers curl over an edge of the housing. Either method of holding the computer is awkward and tiring and requires an application of significant force by user to grip the computer. In addition, repetitive use of the computer can cause discomfort because the user must angle his or her wrist to orient the display screen in a readable position.

The weight of a pen computer is appreciable, approximately five pounds. Holding such a five pound instrument for extended periods with one hand will induce fatigue in the user's grasping hand, wrist and arm. Compounding this problem is the fact that the user must use the pen in his or her writing hand, thereby precluding the possibility of alternating the hand holding the computer to ameliorate fatigue.

Similarly, a touch screen computer is held in one hand or supported by the user's forearm as described above. The user employs the index finger of his or her free hand (usually the writing hand) to appropriately touch the screen.

Ergonomic theories teach the importance of designing products suitable to human physiological capabilities and limitations. A pen computer or touch screen computer which does not provide an ergonomically proper means of holding and

positioning the computer can lead to a marked decline in user productivity as the work day continues as a result of increasing fatigue. Additionally, subjecting a user of a pen or touch screen computer to hand, wrist and arm fatigue may result in long term health problems such as carpal tunnel syndrome.

5

Disclosure of the Invention

A hand-held portable computer made according to this invention includes a housing at least partially enclosing computer electronics, a visible display screen supported by the housing and a handle assembly connected to the housing. The handle assembly includes a handle support, a support retainer affixed to the housing at a location opposite the screen and a handle supported by the handle support. The support retainer adjustably connects the handle support to the housing.

10

In the preferred embodiment, the handle support is rotatably adjustable with respect to the housing. The handle support includes an annular ring having indentations on one surface and the support retainer includes a detent which engages an aligned one of the indentations to secure the handle support in a desired rotational orientation. The support retainer further includes an annular surface and shoulder adjacent its outer periphery providing thrust and bearing surfaces for the handle support annular ring. The annular ring includes a pair of handle attachment members which extend outwardly from the annular ring and away from the housing. The handle attachment members optionally support a plurality of handle configurations.

15

20

As the handle support and handle may be rotatably adjusted with respect to the housing, a user of the pen computer will choose a rotation orientation which is comfortable and secure. If the user tires of a chosen handle orientation, the position of the handle may be expeditiously changed to a new desired position. Additionally, a variety of handle configurations afford the user the opportunity to select an ergonomically proper handle size and shape.

25

30

In an alternate embodiment, the handle assembly functions as a universal joint in that it is both rotatably and pivotably adjustable with respect to the housing. The handle assembly includes a handle support rotatably affixed to the

housing, a pair of handle attachment extensions hinged to the handle support and a handle supported by the pair of handle attachment extensions. A cam latching mechanism secures the handle support in a desired rotational orientation with respect to the housing. A surface of the housing facing the handle support assembly includes a plurality of aligned indentations. A detent affixed to the handle support interfits with an aligned one of the indentations to secure the handle support in the desired rotational orientation. Another cam latching mechanism secures the handle attachment extensions and the handle in a desired angular position with respect to the housing. The cam latching mechanism includes a plurality of indentations on one of the handle support and the handle attachment extension and other of the handle support and handle attachment extension has a detent which engages an aligned one of the indentations to secure the handle attachment extension in the desired angular orientation.

This embodiment provides an additional flexibility in positioning the handle as the handle is both rotationally and pivotably adjustable with respect to the housing. The handle may be advantageously pivoted to a position adjacent the housing when the computer is not being used thereby moving the handle out of harm's way, providing a streamlined appearance and occupying a minimum of space.

In a third embodiment, the computer includes a display screen housing supporting a visible display screen and a computer housing and handle assembly. The computer housing and handle assembly is rotatably affixed to the display screen housing. The computer housing and handle assembly includes a computer housing which encloses computer electronics, a handle subassembly is coupled to the computer housing and includes a handle for holding the computer and a cam latching mechanism to secure the computer housing and handle assembly in a desired rotational orientation with respect to the display screen housing. The cam latching mechanism includes a plurality of indentations on one of the display screen housing and the housing and handle assembly and the other of the two includes a detent which engages an aligned one of the indentations to secure the housing and handle assembly in the desired rotational orientation. The latching

cam mechanism further includes a detent biasing means for biasing the detent to engage the aligned indentation.

In another embodiment, the handle assembly includes a raised member which slidably interfits in a slot in the computer housing. The user can slide the handle assembly along a path of travel parallel to a surface of the computer housing to a selected position.

These and other objects, advantages and features of the invention will become better understood from a detailed description of a preferred embodiment which is described in conjunction with the accompanying drawings.

Brief Description of the Drawings

Figure 1 is a top plan view of the hand-held computer of the present invention;

Figure 2 is a bottom plan view of the computer of Figure 1 showing a rotatably adjustable handle assembly;

Figure 3 is a view, partially in elevation and partially in section, of the computer shown in Figure 1, the sectional portion of the view as seen from the plane indicated by line 3-3 of Figure 2;

Figure 3A is an enlarged sectional view of a cam latching mechanism of the handle assembly as seen from the plane indicated by line 3A-3A of Figure 2, an engaged position being shown in solid and a nonengaged position being shown in phantom;

Figure 4 is an exploded view of the handle assembly of Figure 2, a second position of a handle support and handle are shown in phantom;

Figure 5 is a bottom plan view of a hand-held computer having a pivoting and rotatably adjustable handle assembly;

Figure 6 is an elevation view of the computer of Figure 5 as seen from the plane indicated by line 6-6 of Figure 5;

Figure 7 is a bottom plan view of a held computer having a housing rotatably adjustable with respect to a visible display screen;

Figure 8 is an elevation view of the computer of Figure 7 as seen from the plane indicated by line 8-8 of Figure 7;

Figure 9 is a perspective view of a hand-held computer having an adjustable handle assembly which a user may selectively position along a path of travel parallel to a surface of the computer housing;

5 Figure 10 is an enlarged sectional view showing the attachment structure of the handle assembly and the housing of the hand-held computer of Figure 9 showing the attachment structure between the handle assembly and the housing; and

10 Figure 11 is a perspective view of a hand-held computer having a pivoting handle assembly wherein the handle assembly is affixed to an upper surface of a housing, the upper surface of the housing supporting a video display screen.

Detailed Description

Turning to the drawings, Figures 1-4 illustrate the preferred embodiment of a hand-held computer, shown generally at 10. The computer 10 includes a
15 housing 12 enclosing a microprocessor (not shown) and associated computer circuitry (not shown). An interactive display screen 14 (Figure 1) is coupled to and forms a part of the housing 12. An electronic pen 15, which is not attached to the computer 10, is employed by a user of the computer to input data and
20 commands by appropriately touching a tip of the pen to the display screen 14. Of course, it should be appreciated that the electronic pen 15 may be tethered to the housing 12. A handle assembly 20 is attached to the housing 12 adjacent a housing surface 16 opposite the display screen 14.

As best seen in Figure 4, the handle assembly 20 includes a handle support
25 22, a support retainer 24 and a handle 26. The handle support 22 includes an annular ring 30 having a plurality of indentations 32 separated by rounded raised cam portions or ridges 33. The cam portions 33 are formed in a housing support surface facing the support retainer 24. The handle support 32 also includes a pair of handle attachment members 34. Each handle attachment member 34 includes an extending portion 35 which extends outwardly from the annular ring 30 and an
30 angled portion 36 extending away from the housing surface 16.

The annular ring 30 is rotatably secured between the support retainer 24 and the housing surface 16. A screw 40 connects the support retainer 24 to the

housing 12 and, thereby, secures the handle support 22 in place. The screw 40 extends through an aperture 42 in the support retainer 24 and is threaded into a bore 44 in the housing 12. To provide a clean appearance, a cap 46 snaps onto the support retainer 24 and overlies a head portion of the screw 40.

5 The annular ring 30 is rotatable with respect to the housing 12 and the support retainer 24. If the coupling between the support retainer 24 and the housing 12 provided by the screw 40 is sufficiently tight, the frictional forces opposing relative movement between the annular ring 30 and the housing and support retainer will be sufficient to hold the handle support 22 in a desired
10 rotational position with respect to the housing. Alternatively, a friction brake (not shown) could be used to secure the handle support 22 in the desired position. Preferably, however, the support retainer 24 includes a cam latching mechanism in the form of a detent 50 which interfits into an aligned one of the annular ring indentions 32. As can best be seen in Figure 3A, the detent 50 is biased toward
15 engaged positions. The biasing of the detent 50 toward engaged positions may result from the resiliency of a material the detent is comprised of, for example, polypropylene or another resilient plastic or vinyl material. Alternately and preferably, a spring (not shown) is operably interposed between the detent and a surface of the support retainer to provide the desired engagement biasing.

20 To rotate the handle support 22 with respect to the housing 12, the user holds the housing with one hand and grasps the handle 26 with the other hand and relatively rotates them. Two handle positions (one being in phantom) are shown in Figure 4. When a sufficient force is applied to the handle 26, the attached
25 annular ring 30 will rotate with respect to the housing 12 and the support retainer 24. The detent 50, affixed to the support retainer 24, remains rotatively stationary and functions as a cam follower as it bears against and follows the rotating annular ring surface. As shown in phantom in Figure 3A, the detent 50 will be displaced from its indentation engaged position when a ridge 33, separating adjacent indentations 32, cams the detent. The detent 50 will ride up one face of the ridge
30 and down an opposing face as the annular ring 30 is rotated. The camming action of the detent 50 is facilitated by a tapered surface contour of the ridges 33. Additionally, a bearing surface 52 of the detent 50 is also tapered. Once the

handle 26 is in the desired rotational position with respect to the housing 12, the computer 10 is ready for operation.

The support retainer 24 further includes an annular surface and shoulder 54 (shown in Figure 3 and in phantom in Figure 2) adjacent an outer peripheral surface which provides thrust bearing and radial bearing surfaces for the annular ring 30. The angled portions 36 of the handle attachment members 34 terminate in end pieces 56 which include recessed portions (not shown) having central apertures. The handle 26 is secured between the recessed endpieces. A selected one of a variety of handle configurations may be employed including straight cylindrical handle (shown in Figures 1-4), an arcuate handle (shown in Figures 5 and 6), etc.

An alternate embodiment of the present invention is illustrated in Figures 5 and 6. In this embodiment, a pen computer 60 includes a handle assembly 62 including handle support 64 rotatably attached to a computer housing 66. A screw (not shown) overlaid by a cap 67 secures the handle support 64 to the housing 66. A surface of the computer housing 66 includes an aligned plurality of indentations 68 spaced apart by raised cam portions or ridges. The indentations 68 define a camming surface for a detent 70 protruding from a surface of the handle support 64 facing the housing 66. The detent and camming surface comprise a cam latching mechanism which secures the handle support 64 in a desired rotational orientation with respect to the housing 66.

Additionally, the handle assembly 62 includes a pair of handle attachment extensions 72. The handle attachment extensions 72 support an arcuately curved handle 74 and are hinged to the handle support 64 for pivotal adjustment with respect to the housing 66. Another cam latching mechanism is provided to secure the handle attachment extensions 72 in a selected angular relationship with respect to the housing 66. The cam latching mechanism includes a detent (not shown) affixed to one of the handle support extensions 68. This detent interfits with a selected one of an aligned plurality of indentations (not shown) on the handle support 64 to secure the handle attachment extensions 72 in the desired angular orientation with respect to the housing 66.

Extreme adjustment positions of the handle support extensions 72 and the handle 74 are respectively shown in phantom and solid lines in Figures 5 and 6. The phantom position would be used when the computer 60 is not in operation. As can be seen in Figure 6, the phantom position provides a "low profile" look to the computer and positions the handle 74 and handle attachment extensions 72 out of harm's way.

A third embodiment of the present invention is shown in Figures 7 and 8. In this embodiment, a hand-held computer 80 includes a display screen housing 82 supporting a display screen (not shown). The computer 80 also includes a computer housing and handle assembly 84 rotatably secured to the display screen housing 82. The computer housing and handle assembly 84 includes a computer housing 86 and a handle subassembly 88. A surface of the display screen housing 82 includes an aligned plurality of indentations 89 (shown in phantom in Figure 7) spaced apart by raised cam portions or ridges (also shown in phantom). The indentations 89 and ridges define a camming surface for a detent 90 protruding from a surface of the computer housing 86 facing the display screen housing 82. The detent and camming surface comprise a cam latching mechanism which secures the computer housing and handle assembly 84 in a desired rotational orientation with respect to the display screen housing 82. Alternately, the positions of the detent 90 and camming surface may be reversed, that is, the aligned plurality of indentations 88 may be disposed on a surface of the computer housing 86 and the detent 90 may protrude from a surface of the display screen housing 82 facing the computer housing 86.

The handle assembly 88 also includes a pair of handle attachment extensions 94 supporting a handle 96. The handle attachment extensions 94 are hinged to a support member (not shown) of the handle assembly 88 so as to pivot with respect to the display screen housing 82. Another cam latching mechanism (not shown) is provided to secure the handle attachment extensions 94 in a desired angular orientation with respect to the display screen housing 82 as described in the previous embodiment.

A fourth embodiment of the present invention is shown in Figures 9 and 10. In this embodiment, a hand-held computer 100 includes a handle assembly 102

slidably adjustable in a line parallel to a surface 104 of a housing 106. The housing surface 104 preferably includes two spaced-apart parallel slots 108 (although it should be understood that one slot would be sufficient to perform the function). As can best be seen in Figure 10, the handle assembly 102 includes two parallel extensions 110 which extend from a base 112 of a hand support 114 and slidably interfit in respective slots 108. The extensions 110 are T-shaped in cross-section and are sized to snugly interfit in the slots 108. The interfit is tight enough such that frictional forces prevent the handle assembly 102 from freely moving along its path of travel but not so tight as to prevent the user from moving the handle assembly by applying a force to he or she desires to change the handle position.

Alternately, a cam latching mechanism could be provided to insure positive latching of the handle assembly 102 in the selected position. The cam latching mechanism would be comprised of a plurality of surface indentations (not shown) in a portion of one of the slots 108 and an interfitting detent (not shown) extending from a corresponding surface of the one of the handle assembly extensions 110. Alternatively, the relative positions of the surface indentations and the detent could be reversed, with the plurality of surface indentations (not shown) in a portion of one of the handle assembly extensions 110 and the detent (not shown) extending from a corresponding surface of the one of the handle assembly extensions 110.

Yet another embodiment of a hand-held computer 120 of the present invention is shown in Fig. 11. In this embodiment, a handle assembly 122 is pivotably adjustable with respect to a housing 124. The handle assembly 122 includes a pair of handle attachment extensions 126 supporting a handle 128. The handle extensions 126 are affixed to a cylindrical pin 130. Ends of the pin 130 are rotatably supported by flanges 132 extending from the housing upper surface.

A cam latching mechanism is provided to permit the handle attachment extensions 126 to be pivotably adjusted and secured in a selected angular relationship with respect to the housing upper surface. The cam latching mechanism includes a detent (not shown) affixed to one of the handle attachment extensions 126. This detent interfits with a selected one of an aligned plurality of

indentations (not shown) on one of the flanges 132 to secure the handle attachment extensions 72 in the selected position. Alternatively, the cam latching mechanism could reverse the respective positions of the detent and the plurality of indentations, with the detent affixed to one of the flanges 132 and the plurality of indentations on the handle attachment extensions 72.

Although the invention has been described in its preferred form with a certain degree of particularity, it is understood that the present disclosure of the preferred form has been made only by way of example and that numerous changes in the details of construction, operation and the combination and arrangement of parts may be resorted to without departing from the spirit and the scope of the invention as hereinafter claimed.

CLAIMS

1. A hand-held computer for supplying data to and receiving data from a user, the computer comprising:
- 5 a) a housing and display screen structure delineating an internal space for housing computer components for providing displays on the screen and receiving and processing user provided information input via the screen;
- b) a means for imputing data via the display screen;
- c) a handle for use by a user in supporting the housing and screen structure;
- 10 d) handle connection structure adjustably interconnecting the housing and screen structure and the handle; and
- e) the connection structure including relatively moveable components adapted to enable relative adjustment movement between the handle and screen structure to permit a user to relatively position the handle and the housing and screen structure to an ergonomically acceptable position for support
- 15 of the computer with one hand and data input with the user's other hand.
2. The handle held computer of claim 1 wherein the handle includes an interior space for housing computer components.
3. The handle held computer of claim 1 wherein the connection structure includes a rotatable connection enabling relative rotational movement between said handle housing and screen structure.
4. The hand-held computer of claim 1 wherein the connection structure includes a pivotable connection enabling relative pivotal movement between said handle and said housing screen structure.
5. The hand-held computer of claim 1 wherein the connection structure includes a slidable connection enabling relative linear movement between said handle and said housing and screen structure.

6. The hand-held computer of claim 1 wherein the computer is a pen computer and data is input to the computer by contacting the display screen with an electromagnetic pen.

7. The hand-held computer of claim 1 wherein the computer is a touch screen computer having a touch sensitive display screen.

8. A hand-held portable computer comprising:

- a) a housing at least partially enclosing computer electronics;
- b) a visible display screen supported by the housing;
- c) a handle assembly connected to the housing, the handle

5 assembly including:

- i) a handle support;
- ii) a support retainer affixed to the housing, the retainer adjustably connecting the handle support to said housing; and
- iii) a handle supported by the handle support.

9. The hand-held portable computer of claim 8 wherein the support retainer is affixed to the housing at a location opposite the visible display screen.

10. The hand-held portable computer of claim 8 wherein the handle support is rotatably adjustable with respect to the housing, the handle support including an annular ring having a plurality of indentations on one surface and the support retainer including a detent which engages an aligned one of the
5 indentations to secure the handle support in a desired rotational orientation.

11. The hand-held portable computer of claim 9 wherein the handle support annular ring includes a pair of handle attachment members which extend outwardly from the annular ring and away from the housing.

12. The hand-held portable computer of claim 9 wherein the handle assembly support retainer includes an annular surface and shoulder adjacent an

outer periphery providing thrust and radial bearing surfaces for the handle support annular ring.

13. The hand-held portable computer of claim 9 wherein the handle assembly support retainer includes a detent biasing means for biasing the detent toward engagement with the aligned annular ring indentation.

14. The hand-held portable computer of claim 9 wherein the handle assembly support retainer includes two spaced apart detents protruding from a surface of the support retainer facing the handle support engaging an aligned two indentations on the handle support to secure the handle support in the desired rotational position.

5

15. The hand-held portable computer of claim 8 wherein the handle assembly support retainer is affixed to the housing by a locking screw extending through an aperture in the support retainer and into a threaded aperture in the housing, the locking screw being adjustable to restrict relative movement between said support retainer and said housing.

16. The hand-held portable computer of claim 8 wherein an outer surface of the handle is cylindrical.

17. The hand-held portable computer of claim 7 wherein the handle assembly further includes a handle attachment extension pivotably adjustable with respect to the housing and a latching means for securing the handle attachment extension in a desired angular orientation with respect to the housing, the handle attachment extension having a first and second end, the handle being affixed to the first end of the handle attachment extension and the second end of the handle attachment extension being hinged to the handle support.

5

18. The hand-held portable computer of claim 15 wherein the handle assembly latching means includes a plurality of indentations on one of the handle

support and the handle attachment extension and other of the handle support and handle attachment extension having a detent which engages an aligned one of the plurality of indentations to secure the handle attachment extension in the desired angular orientation.

19. A hand-held portable computer comprising:

- a) a display screen housing supporting a visible display screen;
- b) a computer housing and handle assembly rotatably affixed to

the display screen housing, the housing and handle assembly including:

- i) a computer housing at least partially enclosing computer electronics;
- ii) a handle subassembly coupled to the computer housing and including a handle for holding the computer; and
- iii) a latching mechanism to secure the computer housing and handle assembly in a desired rotational orientation with respect to the display screen housing.

20. The hand-held portable computer of claim 19 wherein the housing and handle assembly latching mechanism includes a plurality of indentations on one of the display screen housing and the computer housing and handle assembly and other of the display housing and the computer housing and handle assembly having a detent which engages an aligned one of the indentations to secure the computer housing and handle assembly in the desired rotational orientation.

21. The hand-held portable computer of claim 19 wherein the computer housing and handle assembly latching mechanism includes a detent biasing means for biasing the detent toward engagement with the aligned indentation.

22. The hand-held portable computer of claim 19 wherein the computer housing and handle assembly is affixed to the display screen housing by a screw extending through an aperture in the computer housing and handle assembly.

23. A method of operating a hand-held portable computer comprising:
- a) relatively moving a computer body and an adjustably connected handle until the handle and body are in an ergonomically comfortable relative position;
 - 5 b) grasping the handle with one hand and positioning a viewing screen in a desired position for inputting data; and,
 - c) inputting data into the computer by contacting the screen as the screen is held in the desired position.

24. The method of operating a portable hand-held computer set forth in claim 20 wherein the handle is in a storage position prior to the relatively moving step and is returned to the storage position subsequent to the inputting data step.

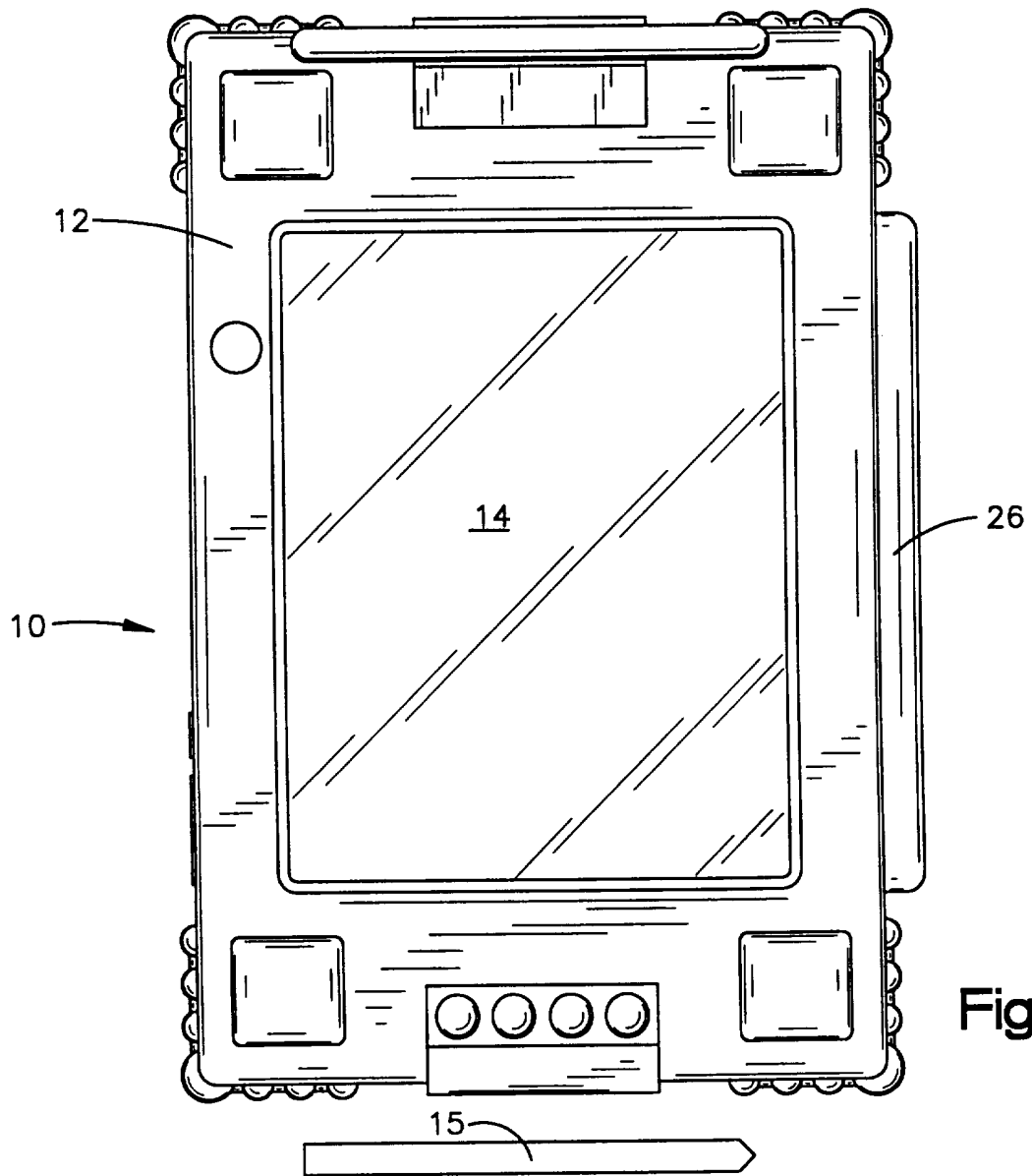

Fig.1

2/7

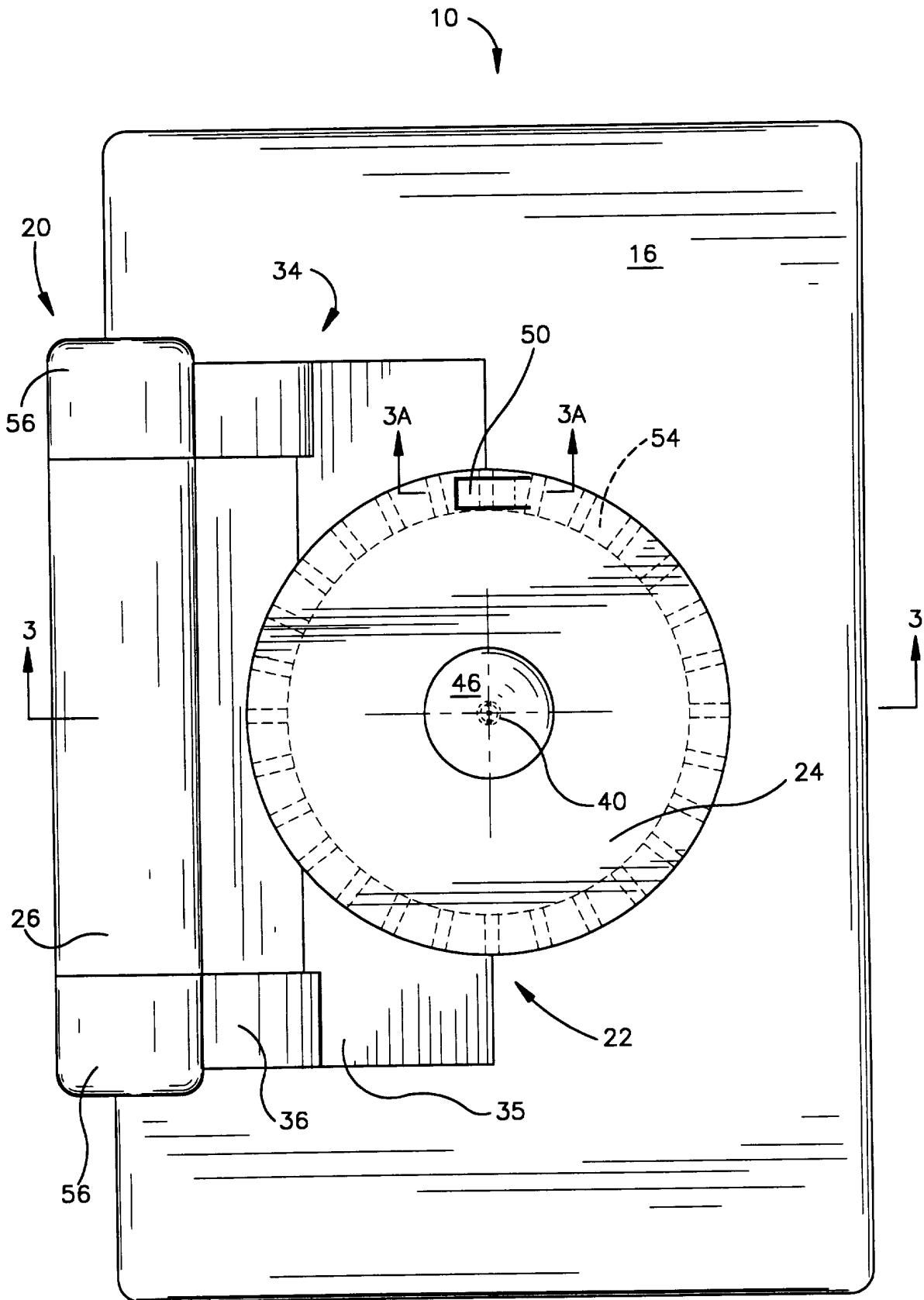

Fig.2

SUBSTITUTE SHEET (RULE 26)

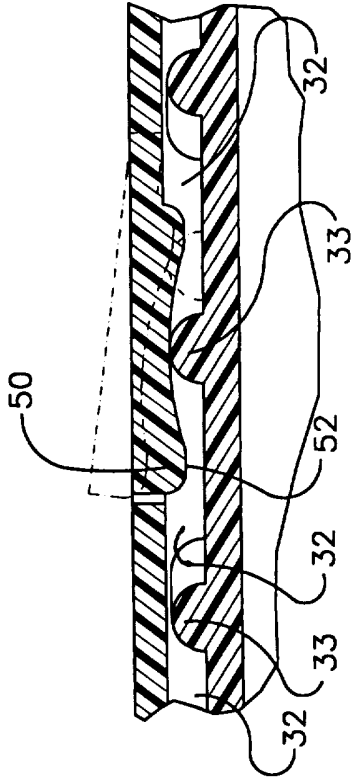

Fig.3A

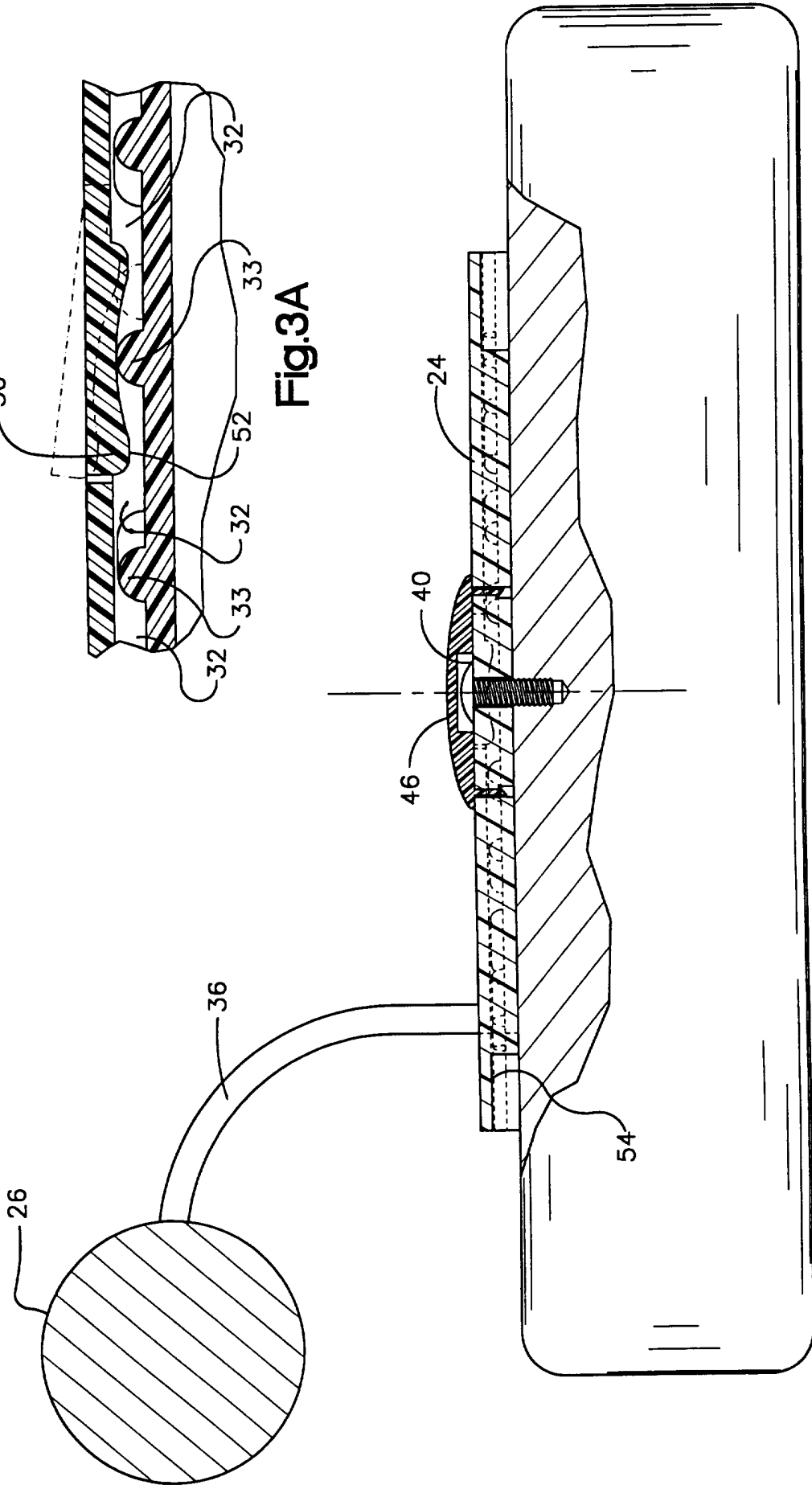

Fig.3

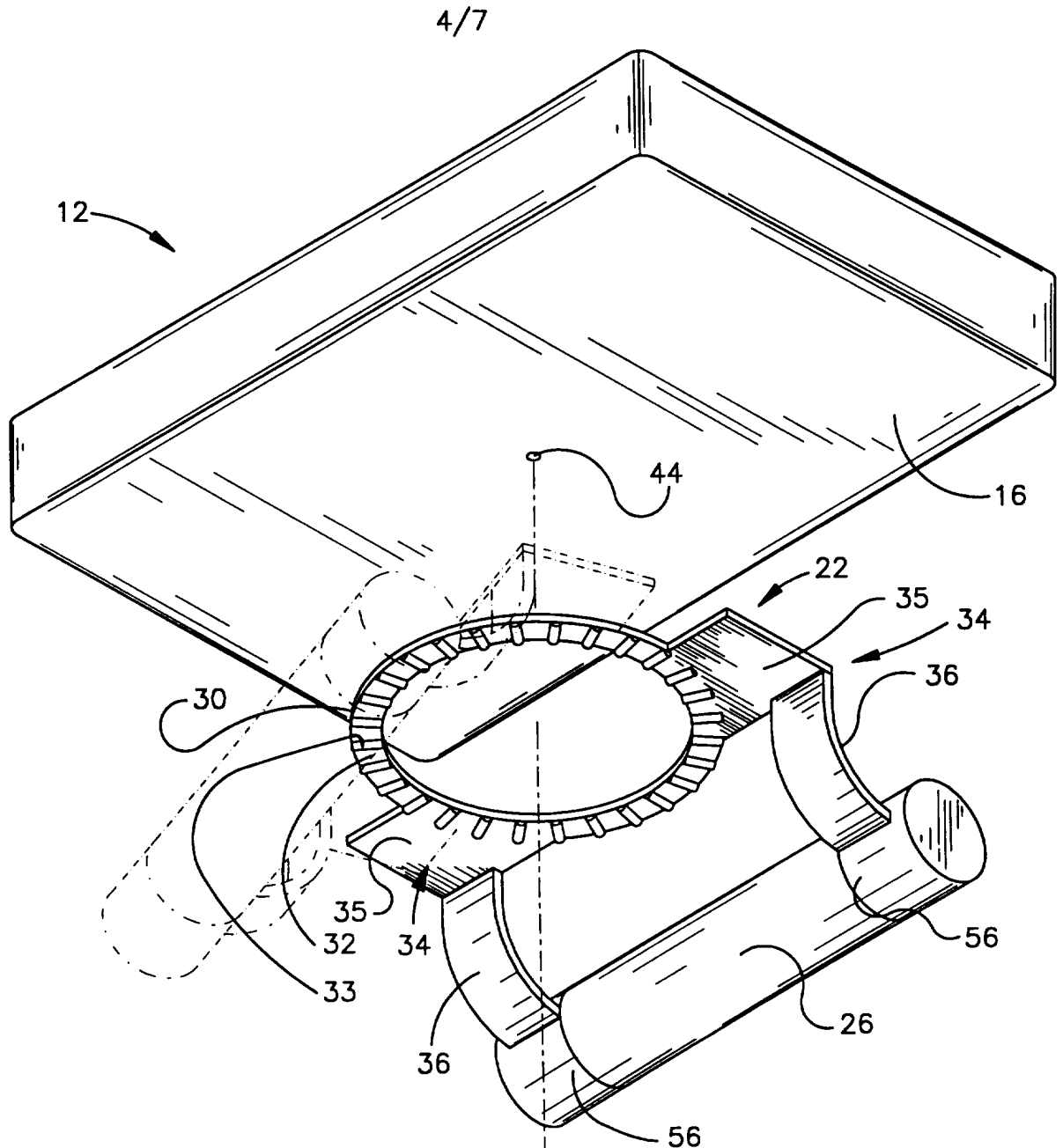
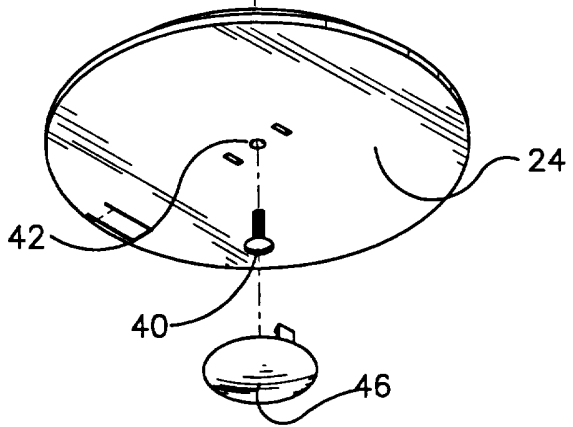

Fig.4



5/7

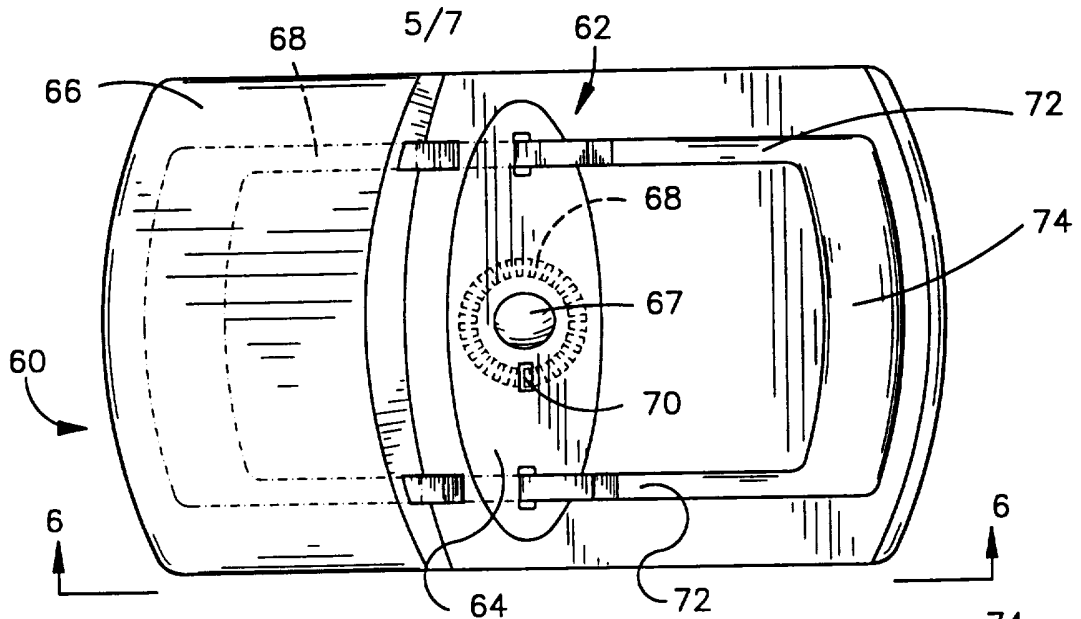

Fig. 5

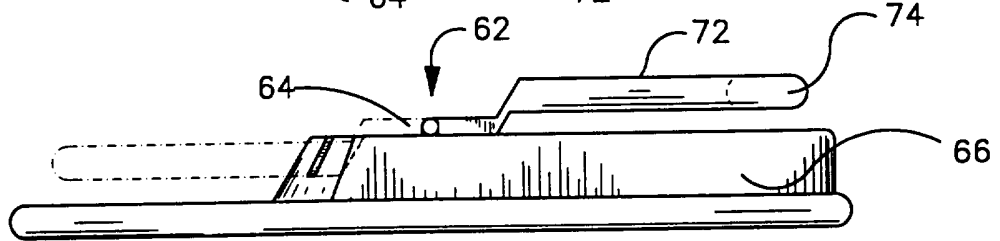

Fig. 6

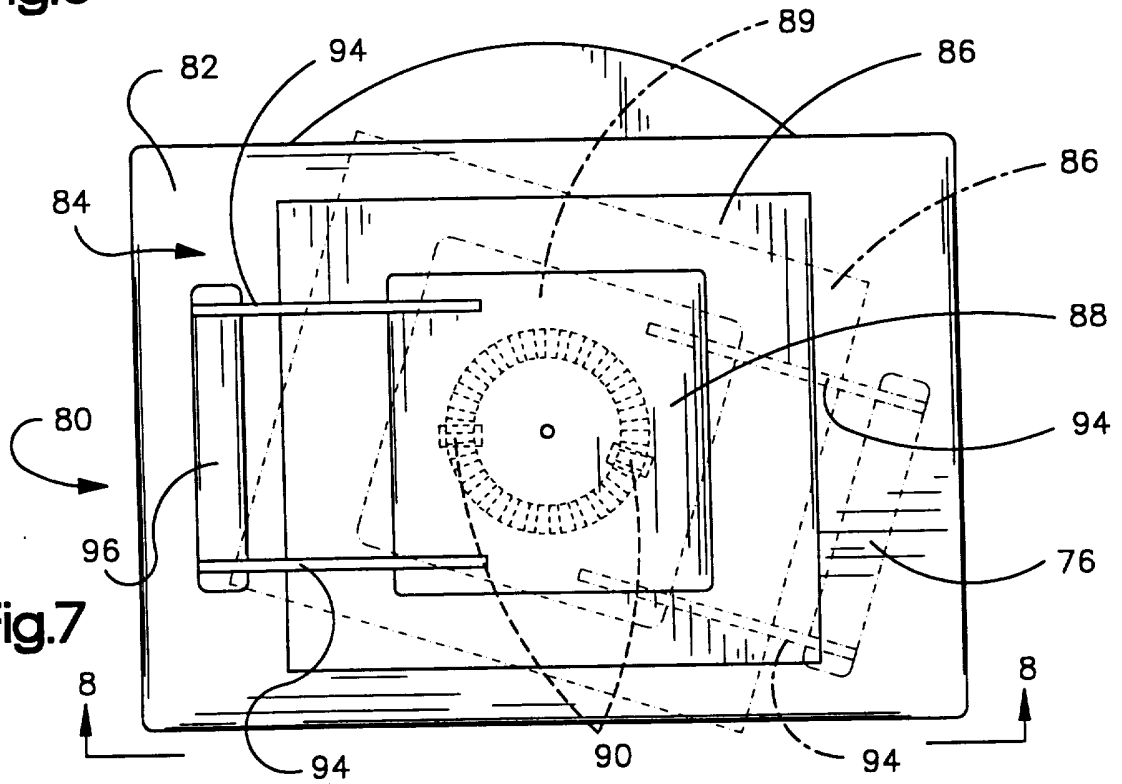

Fig. 7

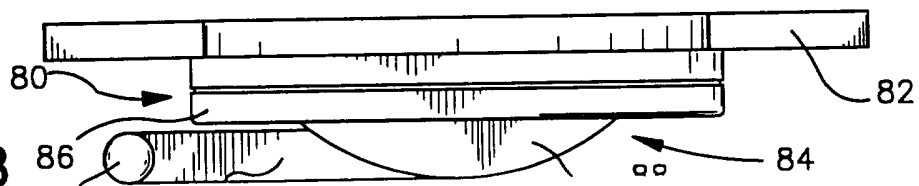

Fig. 8

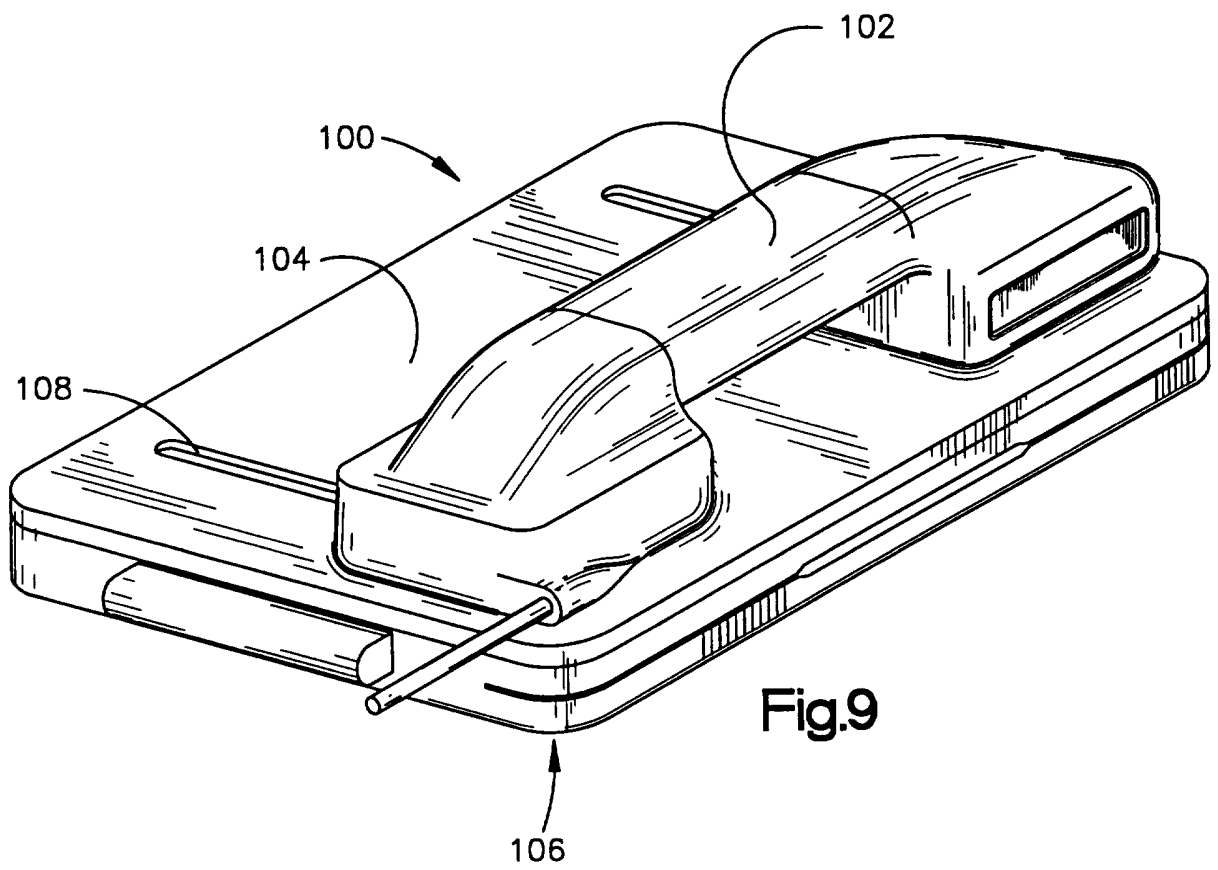

Fig.9

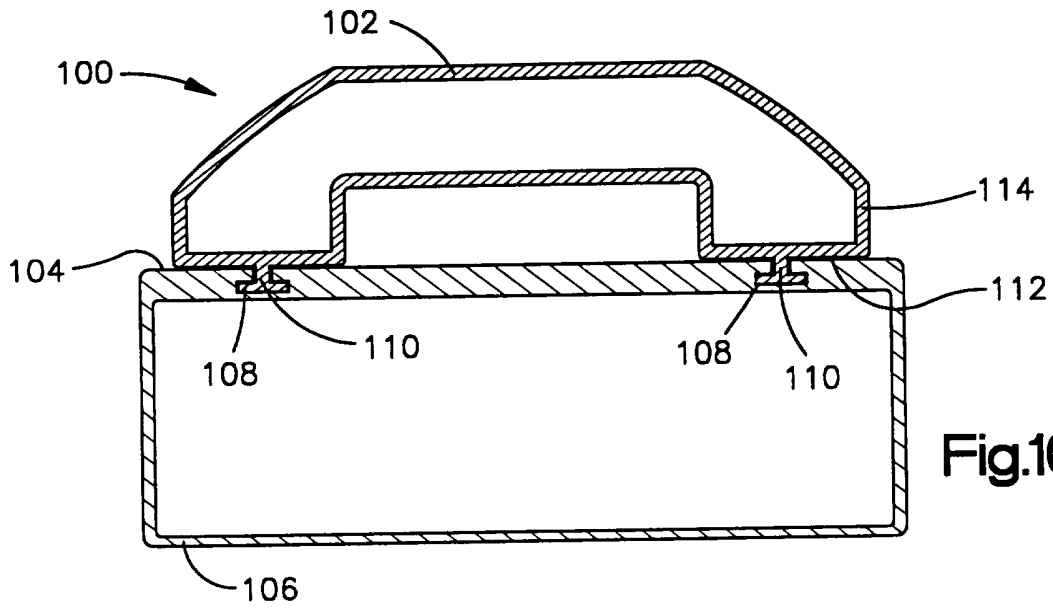

Fig.10

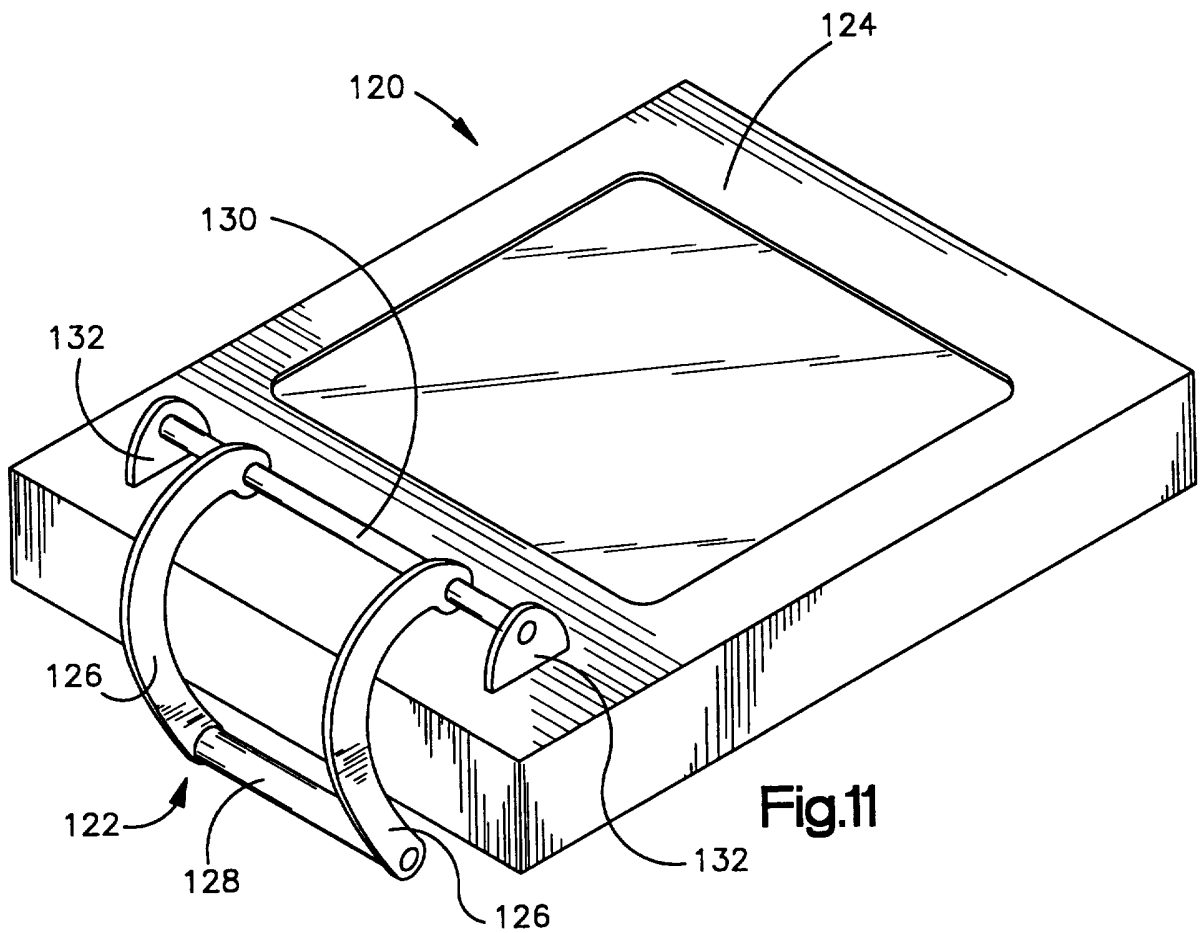

Fig.11

INTERNATIONAL SEARCH REPORT

International application No.
PCT/US95/14408

A. CLASSIFICATION OF SUBJECT MATTER

IPC(6) :G09G 5/00
US CL :345/156

According to International Patent Classification (IPC) or to both national classification and IPC

B. FIELDS SEARCHED

Minimum documentation searched (classification system followed by classification symbols)

U.S. : 345/169-183, 156; 178/18, 19, 20; 364/900; 455/347-351

Documentation searched other than minimum documentation to the extent that such documents are included in the fields searched

Electronic data base consulted during the international search (name of data base and, where practicable, search terms used)

C. DOCUMENTS CONSIDERED TO BE RELEVANT

Category*	Citation of document, with indication, where appropriate, of the relevant passages	Relevant to claim No.
Y	US, A, 4,237, 540 (Sato) 02 December 1980, see column 3, lines 3-9.	1-24
Y	US, A, 4,458,238 (Learn)03 July 1984, see column 3, lines 52-62.	1-24
Y	US, A, 4,916,441 (Gombrich) 10 April 1990, see column 8, lines 3-18; column 7, lines 54-62.	1-24
Y	US, A, 5,349,497 (Hanson et al) 20 September 1994, see column 4, lines 58-64.	1-24

Further documents are listed in the continuation of Box C. See patent family annex.

* Special categories of cited documents:	*T* later document published after the international filing date or priority date and not in conflict with the application but cited to understand the principle or theory underlying the invention
A document defining the general state of the art which is not considered to be part of particular relevance	*X* document of particular relevance; the claimed invention cannot be considered novel or cannot be considered to involve an inventive step when the document is taken alone
E earlier document published on or after the international filing date	*Y* document of particular relevance; the claimed invention cannot be considered to involve an inventive step when the document is combined with one or more other such documents, such combination being obvious to a person skilled in the art
L document which may throw doubts on priority claim(s) or which is cited to establish the publication date of another citation or other special reason (as specified)	*G* document member of the same patent family
O document referring to an oral disclosure, use, exhibition or other means	
P document published prior to the international filing date but later than the priority date claimed	

Date of the actual completion of the international search 21 DECEMBER 1995	Date of mailing of the international search report 08 FEB 1996
Name and mailing address of the ISA/US Commissioner of Patents and Trademarks Box PCT Washington, D.C. 20231 Facsimile No. (703) 305-3230	Authorized officer <i>B. J. Weldon</i> Ulysses Weldon Telephone No. (703) 305-4389