



(11) **EP 2 534 561 B1**

(12) **EUROPEAN PATENT SPECIFICATION**

(45) Date of publication and mention of the grant of the patent:
08.08.2018 Bulletin 2018/32

(51) Int Cl.:
G06F 3/044 ^(2006.01) **G06F 3/01** ^(2006.01)
G06F 3/0488 ^(2013.01)

(21) Application number: **11716367.5**

(86) International application number:
PCT/EP2011/000638

(22) Date of filing: **10.02.2011**

(87) International publication number:
WO 2011/098280 (18.08.2011 Gazette 2011/33)

(54) **COMPUTER KEYBOARD WITH INTEGRATED AN ELECTRODE ARRANGEMENT**

COMPUTERTASTATUR MIT INTEGRIERTER ELEKTRODENANORDNUNG

CLAVIER D'ORDINATEUR AVEC UN ARRANGEMENT D'ÉLECTRODES

(84) Designated Contracting States:
AL AT BE BG CH CY CZ DE DK EE ES FI FR GB GR HR HU IE IS IT LI LT LU LV MC MK MT NL NO PL PT RO RS SE SI SK SM TR

(30) Priority: **10.02.2010 DE 102010007698**

(43) Date of publication of application:
19.12.2012 Bulletin 2012/51

(73) Proprietor: **Microchip Technology Germany GmbH**
85737 Ismaning (DE)

(72) Inventor: **IVANOV, Artem**
82205 Gilching (DE)

(74) Representative: **sgb europe**
Lechnerstraße 25a
82067 Ebenhausen (DE)

(56) References cited:
WO-A2-2008/085418 US-A1- 2006 232 567
US-A1- 2008 042 978 US-A1- 2008 168 403
US-A1- 2009 315 841 US-B1- 6 204 839
US-B1- 6 680 677

EP 2 534 561 B1

Note: Within nine months of the publication of the mention of the grant of the European patent in the European Patent Bulletin, any person may give notice to the European Patent Office of opposition to that patent, in accordance with the Implementing Regulations. Notice of opposition shall not be deemed to have been filed until the opposition fee has been paid. (Art. 99(1) European Patent Convention).

Description

[0001] The invention concerns an input device, in particular in the form of a computer keyboard, that includes a keyboard over which in a per se well-known way by manually pressing keys corresponding keyboard entries can be made.

[0002] Such computer keyboards are widespread as independent peripheral devices or as integrated input system in case of portable computers, especially notebooks.

[0003] Especially for working with graphic user interfaces and using a menu navigation typically implemented here, it is usual to provide, besides a keyboard, also a pointing device like e.g. a computer mouse, a track ball, a graphic tablet or - especially for notebooks - a touch pad. By means of this pointing equipment in a well-known way cursor positions can be manually coordinated. The movements of a cursor correlate with a movement of the mouse, or a movement of a finger on the touch pad.

[0004] Pointing equipment typically also includes additional keys or input elements with which determined operations can be carried out, e. g. a left, middle, and right mouse button for selecting elements of the user interface, a scroll wheel, a wheel button and/or additional keys alongside the mouse or a strip on a touch pad, in which a contact and movement of the finger entails a scrolling, as well as special functions provided in the corners of a touch pad. The functions of some or all these additional keys or input elements can be also configured by the user, e.g. special function calls of the operating system if pressing an additional mouse button or if touching a certain corner of the touch pad.

[0005] The disclosure US2006/0232567 A1 discloses an input device allowing proximity detection of touches based on capacitance measurements.

[0006] The object of the invention is to create solutions in which for a user of a computer keyboard special operator benefits result as compared to conventional keyboard systems in association with a pointing device.

[0007] The abovementioned task can be achieved by an input device as defined in the independent claim. Further embodiments of the invention are specified in the dependent claims. According to an embodiment a computer keyboard may comprise a keyboard that includes a multitude of manually operable keys, and in this keyboard an electrode arrangement is integrated, which is designed, sensed and evaluated via a driver circuit in such a manner that by means of this electrode arrangement the detection of the spatial position or movement of a finger or a hand in an area in front of the keyboard is effected by use of an electrical-field, and wherein by means of the driver, circuit system signals are provided that have an information content that correlates with position and/or movement of a finger or a hand of the user.

[0008] It is thus advantageously possible to use a keyboard as an interface for gesture-like input operations and especially also to command the cursor in a precise

and well coordinated way on a graphic user interface, and also to fulfill additional tasks, without having to remove the hands out of the space above the keyboard for using a pointing device.

[0009] Especially in case of particularly compact portable computers, for example netbooks, the avoidance, allowed by the concept according to the invention, of a touch pad zone and the compactness obtained in this way prove to be particularly advantageous. It is possible to provide special subroutines for the processing of the signals ascertained according to the invention.

[0010] For example it is possible to provide control functions by a corresponding driver, which allow an intuitively particularly well manageable application of the technique according to the invention. For example it is possible to recognize if both hands of the user are detached from the keyboard. The control program can be oriented in such a way that in this state the gesture-based cursor control function is provided and a gesture-like navigation without contact of the cursor on a display is made possible. As soon as one of the two hands contacts the keyboard again, this cursor control mode is finished.

[0011] It is also possible to determine the beginning and the end of the movement of the cursor on the display by pressing one or several keys on the keyboard. These keys can be special keys provided for this function (e. g. mouse button analogously to for example "Scroll Lock", "Num Lock" etc.) or it can be overlapped to the keys already present on the standard keyboard; this superposition of functions can result from the application context (e. g. whenever a character function is called up) or be determined by predetermined keyboard shortcuts possibly configurable by the user (e. g. ALT+C for switching on/out cursor movement, redefinable by a menu).

[0012] It is also possible to determine certain areas on the keyboard in which a cursor movement is induced. These areas can be always provided (e. g. visually marked, possibly an area kept free of keys on the keyboard) or can be switched on and off (e. g. by "Num Lock" switching over between cursor keys ("Pos 1" etc.), number pad ("1", "2" etc.) and cursor movement).

[0013] It is also possible to recognize the beginning and the end of the cursor movement by certain intention-typical movements of the user, e. g. lifting off all fingertips of a hand from the keys introduces a cursor control, laying down fingertips of both hands finishes the cursor control. This embodiment is especially advantageous for experienced touch typing persons, as they typically have the fingertips (apart from the thumb) of both hands on the keys and lift off only one hand in the middle in order to take the mouse with it and move the pointer. The intention-typical movements can be provided together, in a menu that makes it possible for the user to determine or eliminate the action in case of these intention-typical movements from a set of actions. So for example a left-hander can define that when lifting off the left hand the cursor control is switched on, but when lifting off the right hand no action is started. A right-hander could define that

when lifting off the right hand the cursor control is started.

[0014] It is also possible to determine gestures by means of which special programme functions can be activated. For example it is possible to provide own input gestures for a certain activation of the gesture control. For example a movement of the palm of the hand in the fashion of a beckoning from an upper edge area of the keyboard can cause a pull down of the virtual touch pad over the number pad of the keyboard. When not using this feature, by moving the backs of the fingers towards the upper keyboard edge thus by waving aside, this virtual pad can again be pushed away.

[0015] These gestures can also illustrate functions of keys or other input elements that are typically applied on a pointing device, for example the click with the left/right mouse button by fast moving up and down a finger over the left/right input area of the keyboard or a scroll (scroll wheel) by slow movements with the whole hand into X or Y direction above the keyboard. Also a particularly intuitive extension of the range of functions of the display device with further important functions is possible, e. g. augmenting or diminishing a selected object or indicating range by a movement above the keyboard in Z direction.

[0016] The keys or further input elements of a pointing device can also be applied partially or in their entirety on the keyboard, e.g. a touch-sensitive strip for scrolling or keys for the function of the mouse buttons.

[0017] By the concept according to the invention it is possible to create an input device that under inclusion of a technique that can be realized cost-effectively has the advantage that the input device can be well used both by left and right handed persons.

[0018] According to a particularly preferred embodiment of the invention the keyboard is configured in such a way that the electrode arrangement includes a group of electrodes. This group of electrodes preferably includes an electrode subgroup that serves to detect signals indicative of the position.

[0019] The electrode group preferably includes a main electrode serving for contact detection. This main electrode can be designed as a relatively extensive electrode and extend substantially over the total keyboard. This main electrode can be provided with openings, which for example allow the mechanical accessibility of the keys. The main electrode can be realized as a substantially flat metal layer. The main electrode can also be realized in interaction with other components of the keyboard. Especially it is possible to realize the main electrode by a metallic coating of the housing section below the keys of the keyboard, especially also by a metallic coating of the internal area of the keyboard housing. It is also possible to integrate at least some keys into the main electrode. The keys can be metallized for this purpose in the area of their upper side or back side. It is also possible to produce the keys in an electrically conductive material. The metallized, or electrically conductive keys do not have to be necessarily galvanically coupled with the main electrode. It is possible to realize between the main elec-

trode and the keys a certain overlap and thus an electrical-field coupling, so that in the end the field generated by the main electrode can further diffuse over the conductive keys.

[0020] According to a particularly preferred embodiment of the invention the electrodes used as position detection electrodes can be arranged in the area of the number pad, or in the area typically used for the arrow keys. The size of this position detection electrodes can substantially correspond to the size of these keys. The position electrodes can be formed especially by these control keys. In this way it is advantageously possible to use the markings provided there anyway for navigation support for the touchless mouse control mode realizable according to the invention.

[0021] The keyboard according to the invention can be formed in such a way that it performs a dynamic allocation of the single electrodes with determined functions. For example it is possible in a primary recognized approach of a hand or a finger to use an electrode group for the precise determination of the position, that makes possible a particularly good triangulation of the finger or hand position. Ideal are electrodes situated with respect to the current finger position in the area of a cone surface the vertically opposed angle of which is in the range 30 to 60°.

[0022] According to a particular aspect of the present invention the electrode arrangement and the respective driver circuit are configured in such a way that they can detect a state to be considered a touch of the keyboard, and corresponding system signals are generated. This contact can be detected on the basis of certain signal levels and/or certain dynamic characteristics.

[0023] The keyboard according to the invention is preferably configured in such a way that a vertical projection of the observation area used for the position detection of a finger in the keyboard plane extends in a contact detection range. In this way it is possible at first to perform a cursor control without contact and to conclude this movement set by lowering and laying down the finger on the keyboard. The invention thus especially concerns a system, that makes possible both the detection of a finger movement preliminary to contacting a keyboard and the physical contacting of the keyboard itself. The system makes possible the processing of special gestures that besides a certain spatial course also contain contact phases or are initiated or concluded by them.

[0024] The electrode arrangement is preferably configured in such a way that it includes several electrodes arranged in the edge zone of the keyboard, these electrodes arranged in the edge zone being used for generating the signals indicative of the finger position.

[0025] The system signals generated by the driver circuit connected to the electrode arrangement are used according to the invention for the realization of a gesture-based control. The driver circuit can be formed in such a way that the system signals generated by it exist in a data or signal format usual for computer periphery systems. It is possible to undertake, already in the area of

the driver circuit, a relatively extensive signal preprocessing, by which a certain attenuation, scaling and where applicable also certain effects like a ballistic effect are reached. For the rest the X, Y and preferably also Z axis information obtained according to the invention by means of an electrode arrangement can be processed by a corresponding background program in the actual computer system. Besides the mere realization of a cursor control, the obtained signals can be evaluated also by a gesture detection program. Gesture interpretation and cursor control can be connected.

[0026] According to a particularly preferred embodiment of the invention the electrodes are grouped and arranged in such a way that one electrode subgroup primarily for detecting hand or finger movements of the right working hand and one primarily for detecting hand or finger movements of the left working hand are provided. The signals each time detected by both these electrode groups can be assigned each to a hand of the user. On the basis of these signals special statements can be made. For example a closing signal indicative for the conclusion of a gesture can be generated by touching a component of the keyboard. Especially in the two-hands detection it is possible that a closing signal for a gesture coordinated by the right hand is generated by a contact of the left hand with a keyboard component.

[0027] The driver circuit attached to the electrode arrangement can be formed in such a way that the position detection is done by successively measuring the levels of the voltages which are present at the position detection electrodes. Moreover it is possible to detect the field bridging between the position detection electrodes or the field bridging between the position detection electrodes and the main electrode. This detection can take place especially by voltage or load measurement. The area serving for the spatial detection of the finger position or finger movement can be sized in such a way that it substantially corresponds to the range of motion of the finger in association with a light movement of the hand in the wrist. If the position detection electrodes are arranged as corner electrodes in the area of a number pad of a keyboard, the observation area used for the finger position detection corresponds preferably more or less to a cube with an edge length from 8 to 14 cm. The position resolution is done preferably in the central area and in case of close approach to the keyboard with a greater precision than in the edge zone. It is possible, by a fast stirring movement of the forefinger or middle finger approached up to roughly 5 cm from the keyboard, to induce a cursor centering on the screen and then, by the further finger movement, to perform a corresponding movement of the cursor on the screen. It is possible to perform the cursor control in such a way that, for the cursor movement, finger movements are considered that are carried out in case of a certain Z distance value, thus a sufficiently narrow approach. Movements above a corresponding plane are then disregarded.

[0028] Further particulars and characteristics of the in-

vention result from the following description in association with the drawing. The figures show:

Figure 1 a perspective view to illustrate the use of the invention in a portable computer system;

Figure 2a a sketch to illustrate a conventional computer keyboard used by a user in association with a computer mouse;

Figure 2b another sketch to illustrate a conventional computer keyboard provided in a notebook computer in association with a touch pad;

Figure 3 a schematic representation to illustrate the structure of a computer keyboard according to the invention equipped with hand or finger position detection electrodes close to the border, that includes a number pad;

Figure 4 another schematic representation to illustrate the structure of a computer keyboard according to the invention with hand or finger position detection electrodes, without number pad;

Figure 5 a schematic representation to illustrate the electrode arrangement of a computer keyboard according to the invention, with hand or finger position detection electrodes where the position detection electrodes are situated in the contact detection range;

Figure 6 a sketch to illustrate the connection of the electrodes to a driver or evaluation circuit;

Figure 7 a schematic representation to illustrate the electrode arrangement of a further variant of a computer keyboard according to the invention with hand or finger position detection electrodes;

Figure 8 a circuit sketch to illustrate a first variant of the contact detection with the electrode design according to figure 7;

Figure 9 a circuit sketch to illustrate a second variant for contact detection with the electrode design according to figure 7;

Figure 10 a schematic representation to illustrate a further variant of the coupling of the electrodes to the driver or evaluation circuit;

Figure 11a schematic representation to illustrate the electrode arrangement of a further variant of a computer keyboard according to the invention with hand or finger position detection electrodes;

Figure 12 a schematic representation for the posi-

tioning of the switching areas between keyboard and mouse modes;

Figure 13 a schematic representation to illustrate the use of the switching areas.

Figure 14 a schematic representation of a so-called virtual keyboard, in which the keys are electrically inoperable or no more physically present at all and are operated only by means of gestures and contact.

[0029] Figure 1 shows a notebook computer with a flat display and a keyboard equipment.

[0030] In the area of the keyboard device an electrode device is provided for detecting the position of the finger of a user relatively to the keyboard equipment, without the keyboard being touched. The notebook computer is configured in such a way that the progress of an application program used in association with it can be coordinated by the movement of a finger of the user relative to the keyboard.

[0031] The electrode device includes several electrode sections provided in the area of the keyboard ELP, ELB that are connected to a sensor circuit, in which by that sensor circuit measuring signals are detected and processed, in which those measuring signals are influenced by the effect of the finger of the user on the electric-field properties of the environment of the respective electrode sections ELP, ELB.

[0032] In the embodiment shown here in the area of the flat display device optionally also an electrode device is provided, for detecting the position of a finger of the user in an area in front of the flat display device.

[0033] In the area of the keyboard there is a contact sensor system for detecting a signal indicative of a contact with the keyboard or its surrounding area. In the area of the flat display device there is optionally also a contact sensor system, for detecting a signal indicative of a contact with the flat display device.

[0034] By the electrode system integrated into the portable computer according to the invention it is possible to detect finger movements and approach states of the left and right hand without contact and to command with these detection results the progress of a user program.

[0035] In figure 2a a conventional computer keyboard is illustrated, by means of which in a per se well-known way inputs into a corresponding computer can be done. Such keyboards are used predominantly in association with a computer mouse. By this computer mouse it is possible to carry out a cursor movement correlating with the movement of the mouse.

[0036] This approach has proven successful, however it has the disadvantage that the user when using a computer must turn his hand from the keyboard to the mouse (Fig. 2a).

[0037] In applications like text editor or table editor, in which inputs are mainly done by means of the keyboard and at the same time formatting with the mouse are nec-

essary, this way is not comfortable. Moreover, two devices are necessary for the operation

[0038] In figure 2b a notebook is illustrated that includes an integrated keyboard and a touch pad. By means of the touch pad it is possible to induce cursor movements that correlate with the movement of the finger of a user on the touch pad. This solution is particularly used in notebooks, since no additional devices have to be carried around. Disadvantages of this alternative are a small active surface (for some tasks the operation is too sensitive); moreover space on the surface of the computer is necessary.

[0039] Figure 3 shows in a highly simplified way a keyboard T configured according to the invention that includes several keys K. This keyboard, in an area under the housing surface, is equipped with electrodes, in the following called gesticulation electrodes (outlined by broken lines).

[0040] These electrodes are:

(a) the position detection electrodes EL_P on the edge of the keyboard T and

(b) the contact detection electrode EL_B under the keys K.

[0041] For a representation simplification purpose all of the electrodes are shown as closed.

[0042] However, they can be designed as a grate, a network or a similar locally open structure, in order to procure e.g. necessary space for the key openings. So the contact detection electrode EL_B can be designed as a grate in the free space between the keys. Also in the other illustrations there is this graphic simplification.

[0043] The number of the position detection electrodes EL_P can vary; when it is greater (e.g. 8, as illustrated in figure 3), the movements of both hands can be registered.

[0044] Because of the used technology, i.e. the detection of the position of a finger on the basis of its effect on quasi static electric fields, it is advantageous if the keys K have a possibly flat form, like the keys of notebook keyboards.

[0045] The hand position over the coverage area can be translated directly into the screen-coordinates, for example: right lower area of the keyboard corresponds to the right lower area on the screen. Alternative, the deflection of the hand from the center of the coverage area can command the direction and the speed of the mouse pointer movement on the screen, for example: hand over the center of the keyboard causes no movement of the cursor, hand over right lower area of the keyboard moves the cursor downwards to the right with maximum (preset) speed.

[0046] An additional advantage results from the invention if the keyboard, e.g. in case of notebooks, for space reasons cannot be large. In such portable devices, generally some keys are left away and some keys have more

than one function.

[0047] Here the invention offers an improvement, on the one hand by the fact, that the space hitherto occupied by the touch pad can be used for the keyboard. Moreover it is possible to reproduce, based on the small "base keyboard" (figure 4), the functionality of the full keyboard.

[0048] The concept according to the invention and some examples:

(a) the user moves his right hand over the right edge of the base keyboard from the far right towards the center of the keyboard and with it "brings up" the number pad on the surface of the keyboard; the virtual number pad appears ("enters" from the right) on the screen. Further movements of the right hand of the user move the cursor or alternatively the focus on the virtual number pad. A light touch of the keyboard (without actuating the keys - only touching the surface) can be interpreted by the electronics and the software as typing on the virtual number pad.

(b) the number pad for the left-handers can come from the left side and allows to carry out corresponding inputs with the left hand.

(c) the function keys can be "brought up" from the top.

[0049] The invention also allows a completely gesture controlled operation. An important point is that the invention can be used in connection with existing software applications, and by using the invention the user can pass more easily from the former standard operation towards gesture operation.

[0050] The invention also offers the additional possibilities of the gesture control of existing system commands, e.g. a movement of the hand from top to bottom over the keyboard minimizes all the windows on the screen; the movement of the hand from the right to the left over the complete keyboard means "switch off computer".

[0051] By the concept according to the invention it is also possible to ascertain the existence of a hand or both hands of the user on the keyboard or at least near it, even if no keys are pressed. This information can be of interest for processes of the operating system. Especially in wireless keyboards a temporarily sleep mode can be activated, in which special energy saving functions exist.

[0052] In figure 4 another variant of a computer keyboard - without number pad - is illustrated, which comprises, similarly to the keyboard according to figure 3, position detection electrodes close to the border.

[0053] Figure 5 shows an electrode arrangement with electrodes applied in 2 layers from both sides on an insulating layer (represented as a slice at the bottom of the illustration). The generator electrode GEN extends under all position detection electrodes EL_P as well as under the contact detection electrode EL_B. The electrodes are connected to the gesture electronics according to figure

6.

[0054] In figure 7 another possible realization of the electrodes is illustrated. In this variant the generator electrode GEN is a frame under the position detection electrodes EL_P. The contact detection electrode EL_B is made in only one layer and can be realized e.g. as a grate between the keys or as a conductive foil with the openings for the key bars. Also the complete metallic coating of the keyboard can be used as EL_B. Such an electrode arrangement can be attached to the gesture electronics in various ways, as it is shown typically in the figures 6, 8, 9, and 10.

[0055] Figs. 6 and 10 show by way of example how the contact detection electrode can be connected to one of the entries of the gesture electronics. This entry does not have to be designed specially for this purpose. Figure 10 shows the connection possibility by means of a coupling capacitor CK to the "standard" gesture electronics.

[0056] Figure 8 and figure 9 show this variant with the measurement of the capacitive load at the generator electrode. This can be done for the load C e.g. by measuring the voltage drop at a connection impedance Z connected between the generator G and the generator electrode EL_B (schematically as signal S). This method of detecting the contact can be advantageous as it can be realized with a minor expenditure of electrodes in certain applications. In figure 11 an electrode configuration is illustrated in which all of the position detection electrodes EL_P are made as smaller units (tablets) together with the generator electrodes GEN.

[0057] Alternatively a distinction between the use of the keyboard and motion detection (mouse function) can take place in the following way: Switching areas are defined on the keyboard, starting from which the device is switched over into the mouse mode (or vice versa). These switching areas (example in figure 12 EB1 and EB2) can be defined best over the present electrodes. Their definition can apply for the left hand, for the right hand, or for both hands.

[0058] The function of the invention is then as follows:

(a) the user works on the keyboard. As long as he does not touch any of the switching areas, no gesture data are evaluated.

(b) the user puts his left hand so as to touch one or two of the switching areas with his fingers (Figure 13). In this moment the movements of his right hand are interpreted as mouse movements, the clicks of the mouse are carried out with touching one or the other switching area.

[0059] For this case no contact detection electrode is needed, in its place the generator electrode can be used, as it is marked in Figure 12 with EL_B/GEN.

[0060] Comparable functionalities can take place also with other hand assignments.

[0061] A further embodiment of the invention as for the

detection of clicks in the mouse mode consists in the fact that as soon as the input device is put into this mode, every key actuation at the keyboard is interpreted as a mouse click.

[0062] The function of the invention is then as follows:

(a) the user works on the keyboard. As long as the mouse mode is not activated, no gesture data are evaluated.

(b) the user activates the mouse mode of the input device in one of the ways described before. From this moment the movements of his hand are interpreted as mouse movements, the clicks of the mouse are carried out with the actuation of any keyboard key that in that moment is under his finger or hand. For this case no contact detection electrode is needed, in its place the generator electrode can be used, as this is marked in Figure 12 as EL_B/GEN.

[0063] Another field of application of the invention is illustrated in figure 14. Here a device VT is shown that has no keys and tendentiously looks like an enlarged mouse pad. This device acts as keyboard and pointing device, which is used when using a computer. For the work at the keyboard a virtual keyboard is visualized on the screen (similar to the number pad described before). It may include electrically inoperable keys for generating a tactile feedback. The keys however can also be completely omitted and optionally be printed on the area for orientation. The keyboard can appear as a guidance semitransparent over other applications on the screen or in a (dedicated) partition of the screen; the cursor control is done by gestures as described above. This field can be equipped with a slightly elastic coating. The definitive selection or actuation of a key is done only when exceeding a determined contact pressure or a determined dynamic profile.

[0064] The geometries described above of the electrodes are example embodiments. Also other geometries are possible that can differ from them especially in the form and their relative positions of the electrodes.

Claims

1. Input device with:

- a keyboard that includes a multitude of manually operable keys (K), further comprising:
- an electrode arrangement comprising at least one generator electrode (GEN, EL_B) and a plurality of detection electrodes (EL_B, EL_P), **characterized in that**
- the generator electrode (GEN) receives a drive signal that generates an electrical field between the generator electrode (GEN) and the detection electrodes (EL_B, EL_P);

- an evaluation circuit (GestIC) receiving a plurality of signals from said detection electrodes (EL_B, EL_P) for detection of the position and/or movement of a finger or a hand in an area placed above the input device (T) without touching the input device (T) and being further configured to interpret a gesture made by said finger or hand.

2. Input device according to claim 1, further comprising at least one first electrode (EB1, EB2) configured to detect a touch by a user wherein upon detection of a touch at said first electrode (EB1, EB2) the input device (T) is switched from a keyboard mode into a gesture detection mode.

3. Input device according to claim 1 or 2, comprising at least one second electrode (EB1, EB2) configured to detect a touch wherein upon detection of a touch at said second electrode (EB1, EB2) a signal equivalent to a mouse click is generated.

4. Input device according to claim 3, further comprising a contact detection electrode (EL_B) arranged under and encompassing said multitude of operable keys.

5. Input device according to at least one of claims 1 to 4, wherein the plurality of detection electrodes (EL_B, EL_P) are arranged around said multitude of operable keys (K).

6. Input device according to at least one of claims 1 to 5, wherein the generator electrode (GEN) is arranged in a layer below said plurality of detection electrodes (EL_B, EL_P).

7. Input device according to at least one of claims 1 to 6, wherein the evaluation circuit (GestIC) is configured to generate signals to initiate the showing of a number pad, or function keys on a screen associated with said input device (T).

8. Input device according to claim 6, wherein the generator electrode (GEN) is ringshaped and arranged under the detection electrodes (EL_P) arranged along the edge of the input device (T).

9. Input device according to at least one of claims 1 to 8, **characterised in that** the detection electrodes (EL_P) are grouped and arranged in such a way that there is one electrode subgroup primarily for detecting hand or finger movements of the right working hand and one primarily for detecting hand or finger movements of the left working hand.

10. Input device according to at least one of claims 1 to 9, **characterised in that** a closing signal indicative for the conclusion of a gesture is generated by touching a component of the keyboard.

11. Input device according to at least one of claims 1 to 10, **characterised in that** a closing signal for a gesture coordinated by a hand is generated by a contact of the other hand with a keyboard component.
12. Input device according to at least one of claims 1 to 10, **characterised in that** the keys (K) are electrically inoperable or are completely omitted.
13. Input device according to claim 6, wherein a plurality of generator electrodes (GEN) are provided and wherein each generator electrode (GEN) is associated with a respective detection electrode (EL_P) and arranged under said associated detection electrode (EL_P).
14. Stationary or mobile computer with a display device and an input device according to one of the preceding claims.
15. Stationary or mobile computer according to claim 14 further comprising in the area of the display device an electrode device for detecting the position of a finger of the user in an area placed in front of the display device.

Patentansprüche

1. Eingabevorrichtung, die aufweist:

- eine Tastatur, die eine Vielzahl von manuell bedienbaren Tasten (K) umfasst, die weiterhin aufweist:
- eine Elektrodenanordnung, die zumindest eine Generatorelektrode (GEN, EL_B) und eine Vielzahl von Detektionselektroden (EL_B, EL_P) aufweist, **dadurch gekennzeichnet, dass**
- die Generatorelektrode (GEN) ein Ansteuersignal empfängt, das ein elektrisches Feld zwischen der Generatorelektrode (GEN) und den Detektionselektroden (EL_B, EL_P) erzeugt;
- eine Auswerteschaltung (GestIC), die zur Erfassung der Position und/oder Bewegung eines Fingers oder einer Hand in einem über der Eingabevorrichtung (T) angeordneten Bereich ohne Berührung der Eingabevorrichtung (T) eine Vielzahl von Signalen von den Detektionselektroden (EL_B, EL_P) empfängt und weiterhin konfiguriert ist, eine durch den Finger oder die Hand ausgeführte Geste zu interpretieren.

2. Eingabevorrichtung gemäß Anspruch 1, die weiterhin zumindest eine erste Elektrode (EB1, EB2) aufweist, die konfiguriert ist, eine Berührung durch einen Anwender zu erfassen, wobei bei Erfassung einer Berührung an der ersten Elektrode (EB1, EB2) die Eingabevorrichtung (T) von einem Tastaturmo-

us in einen Gestenerfassungsmodus geschaltet wird.

3. Eingabevorrichtung gemäß Anspruch 1 oder 2, die zumindest eine zweite Elektrode (EB1, EB2) aufweist, die konfiguriert ist, eine Berührung zu erfassen, wobei bei Erfassung einer Berührung an der zweiten Elektrode (EB1, EB2) ein Signal erzeugt wird, das einem Mausklick entspricht.
4. Eingabevorrichtung gemäß Anspruch 3, die weiterhin eine Kontaktdetektionselektrode (EL_B) aufweist, die unter der und die Vielzahl der bedienbaren Tasten umfassend angeordnet ist.
5. Eingabevorrichtung gemäß zumindest einem der Ansprüche 1 bis 4, wobei die Vielzahl von Detektionselektroden (EL_B, EL_P) um die Vielzahl von bedienbaren Tasten (K) herum angeordnet ist.
6. Eingabevorrichtung gemäß zumindest einem der Ansprüche 1 bis 5, wobei die Generatorelektrode (GEN) in einer Schicht unter der Vielzahl von Detektionselektroden (EL_B, EL_P) angeordnet ist.
7. Eingabevorrichtung gemäß zumindest einem der Ansprüche 1 bis 6, wobei die Auswerteschaltung (GestIC) konfiguriert ist, Signale zu generieren, um die Darstellung eines numerischen Tastenfeldes oder von Funktionstasten auf einem der Eingabevorrichtung (T) zugehörigen Bildschirm zu starten.
8. Eingabevorrichtung gemäß Anspruch 6, wobei die Generatorelektrode (GEN) ringförmig ist und unter den entlang der Kante der Eingabevorrichtung (T) angeordneten Detektionselektroden (EL_P) angeordnet ist.
9. Eingabevorrichtung gemäß zumindest einem der Ansprüche 1 bis 8, **dadurch gekennzeichnet, dass** die Detektionselektroden (EL_P) gruppiert sind und auf eine derartige Weise angeordnet sind, dass es eine Elektrodenuntergruppe hauptsächlich zur Erfassung von Hand- oder Fingerbewegungen der rechten Arbeitshand und eine hauptsächlich zur Erfassung von Hand- oder Fingerbewegungen der linken Arbeitshand gibt.
10. Eingabevorrichtung gemäß zumindest einem der Ansprüche 1 bis 9, **dadurch gekennzeichnet, dass** durch Berühren einer Komponente der Tastatur ein Schlussignal erzeugt wird, das indikativ für die Beendigung einer Geste ist.
11. Eingabevorrichtung gemäß zumindest einem der Ansprüche 1 bis 10, **dadurch gekennzeichnet, dass** ein Schlussignal für eine durch eine Hand koordinierte Geste durch einen Kontakt der anderen

Hand mit einer Tastaturkomponente erzeugt wird.

12. Eingabevorrichtung gemäß zumindest einem der Ansprüche 1 bis 10, **dadurch gekennzeichnet, dass** die Tasten (K) elektrisch nicht funktionsfähig sind oder vollständig entfallen. 5
13. Eingabevorrichtung gemäß Anspruch 6, wobei eine Vielzahl von Generatorelektroden (GEN) bereitgestellt wird und wobei jede Generatorelektrode (GEN) einer entsprechenden Detektionselektrode (EL_P) zugehörig ist und unter der zugehörigen Detektionselektrode (EL_P) angeordnet ist. 10
14. Stationärer oder mobiler Computer mit einer Anzeigevorrichtung und einer Eingabevorrichtung gemäß einem der vorherigen Ansprüche. 15
15. Stationärer oder mobiler Computer gemäß Anspruch 14, der im Bereich der Anzeigevorrichtung weiterhin eine Elektrodenvorrichtung zur Erfassung der Position eines Fingers des Anwenders in einem vor der Anzeigevorrichtung angeordneten Bereich aufweist. 20

Revendications

1. Dispositif d'entrée présentant :

- un clavier qui inclut une multitude de touches pouvant être actionnées manuellement (K), comprenant en outre :
- un agencement d'électrodes comprenant au moins une électrode génératrice (GEN, EL_B) et une pluralité d'électrodes de détection (EL_B, EL_P), **caractérisé en ce que** :
- l'électrode génératrice (GEN) reçoit un signal de commande qui génère un champ électrique entre l'électrode génératrice (GEN) et les électrodes de détection (EL_B, EL_P) ;
- un circuit d'évaluation (GestIC) recevant une pluralité de signaux provenant desdites électrodes de détection (EL_B, EL_P), en vue de la détection de la position et/ou du mouvement d'un doigt ou d'une main dans une zone placée au-dessus du dispositif d'entrée (T), sans effleurement du dispositif d'entrée (T), et étant en outre configuré de manière à interpréter un geste réalisé par ledit doigt ou ladite main. 50

2. Dispositif d'entrée selon la revendication 1, comprenant en outre au moins une première électrode (EB1, EB2) configurée de manière à détecter un effleurement réalisé par un utilisateur, dans lequel, suite à la détection d'un effleurement au niveau de ladite première électrode (EB1, EB2), le dispositif d'entrée (T) est commuté d'un mode clavier à un mode de

détection de geste.

3. Dispositif d'entrée selon la revendication 1 ou 2, comprenant au moins une seconde électrode (EB1, EB2) configurée de manière à détecter un effleurement, dans lequel, suite à la détection d'un effleurement au niveau de ladite seconde électrode (EB1, EB2), un signal équivalent à un clic de souris est généré. 5
4. Dispositif d'entrée selon la revendication 3, comprenant en outre une électrode de détection de contact (EL_B) agencée sous et entourant ladite multitude de touches actionnables. 10
5. Dispositif d'entrée selon au moins l'une quelconque des revendications 1 à 4, dans lequel la pluralité d'électrodes de détection (EL_B, EL_P) est agencée autour de ladite multitude de touches actionnables (K). 15
6. Dispositif d'entrée selon au moins l'une quelconque des revendications 1 à 5, dans lequel l'électrode génératrice (GEN) est agencée dans une couche située au-dessous de ladite pluralité d'électrodes de détection (EL_B, EL_P). 20
7. Dispositif d'entrée selon au moins l'une quelconque des revendications 1 à 6, dans lequel le circuit d'évaluation (GestIC) est configuré de manière à générer des signaux pour initier l'affichage d'un pavé numérique, ou de touches de fonction sur un écran associé audit dispositif d'entrée (T). 25
8. Dispositif d'entrée selon la revendication 6, dans lequel l'électrode génératrice (GEN) est en forme d'anneau et est agencée en dessous des électrodes de détection (EL_P) agencées le long du bord du dispositif d'entrée (T). 30
9. Dispositif d'entrée selon au moins l'une quelconque des revendications 1 à 8, **caractérisé en ce que** les électrodes de détection (EL_P) sont regroupées et agencées de telle sorte qu'il existe un sous-groupe d'électrodes destiné principalement à détecter les mouvements de la main ou des doigts de la main de travail droite, et un sous-groupe d'électrodes destiné principalement à détecter les mouvements de la main ou des doigts de la main de travail gauche. 35
10. Dispositif d'entrée selon au moins l'une quelconque des revendications 1 à 9, **caractérisé en ce qu'un** signal de fermeture indicatif de la conclusion d'un geste est généré en effleurant un composant du clavier. 40
11. Dispositif d'entrée selon au moins l'une quelconque des revendications 1 à 10, **caractérisé en ce qu'un**

signal de fermeture pour un geste coordonné par une main est généré par un contact de l'autre main avec un composant de clavier.

12. Dispositif d'entrée selon au moins l'une quelconque des revendications 1 à 10, **caractérisé en ce que** les touches (K) sont inexploitablement ou sont totalement omises. 5
13. Dispositif d'entrée selon la revendication 6, dans lequel une pluralité d'électrodes génératrices (GEN) est fournie, et dans lequel chaque électrode génératrice (GEN) est associée à une électrode de détection respective (EL_P) et agencée en dessous de ladite électrode de détection associée (EL_P). 10
15
14. Ordinateur fixe ou mobile doté d'un dispositif d'affichage et d'un dispositif d'entrée selon l'une quelconque des revendications précédentes. 20
15. Ordinateur fixe ou mobile selon la revendication 14, comprenant en outre, dans la zone du dispositif d'affichage, un dispositif d'électrode destiné à détecter la position d'un doigt de l'utilisateur dans une zone placée en face du dispositif d'affichage. 25

30

35

40

45

50

55

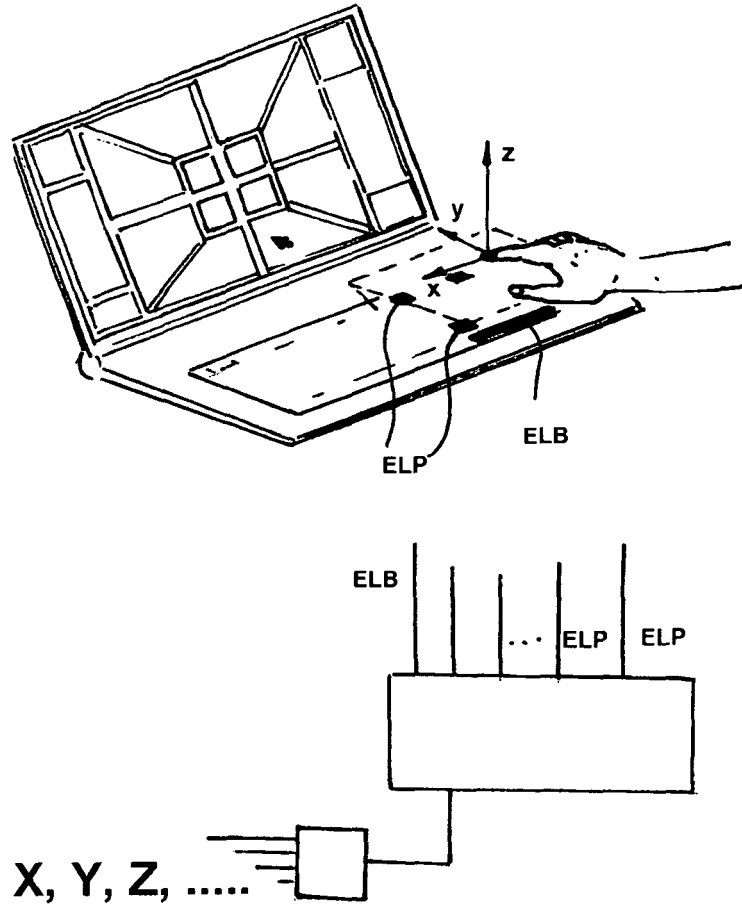

Fig. 1

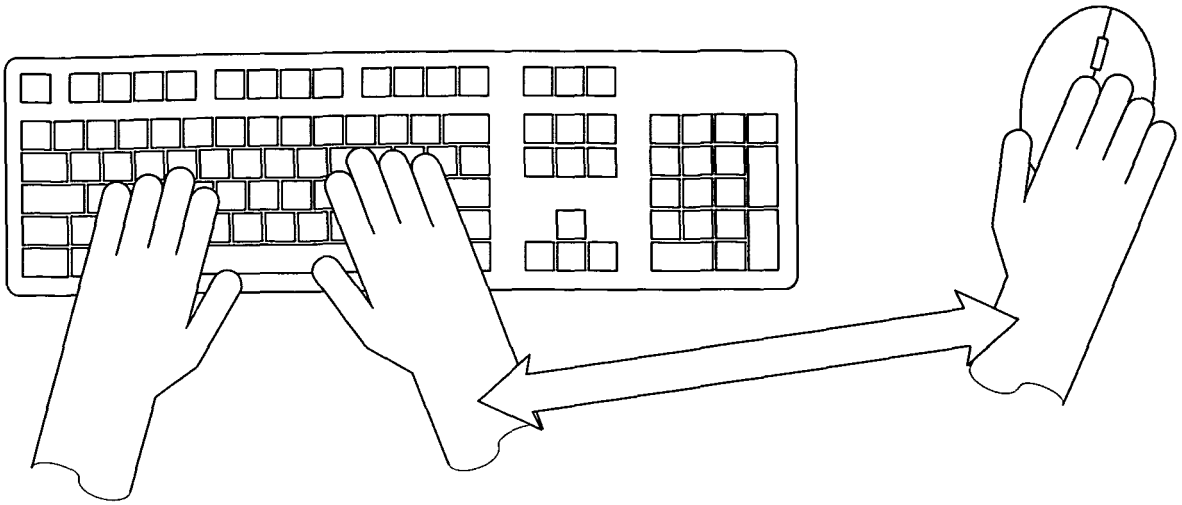

Fig. 2a

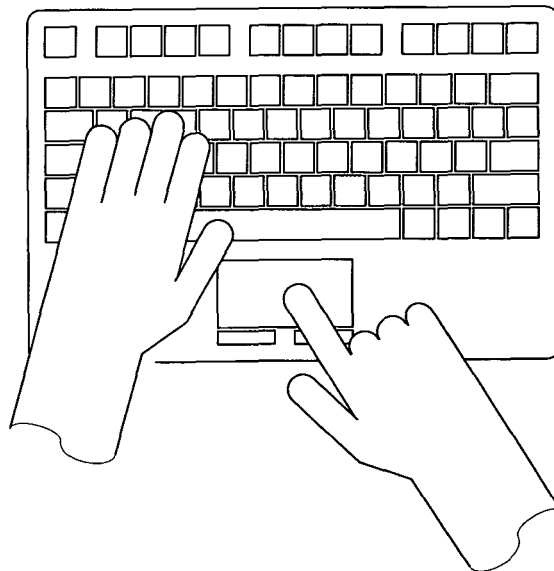
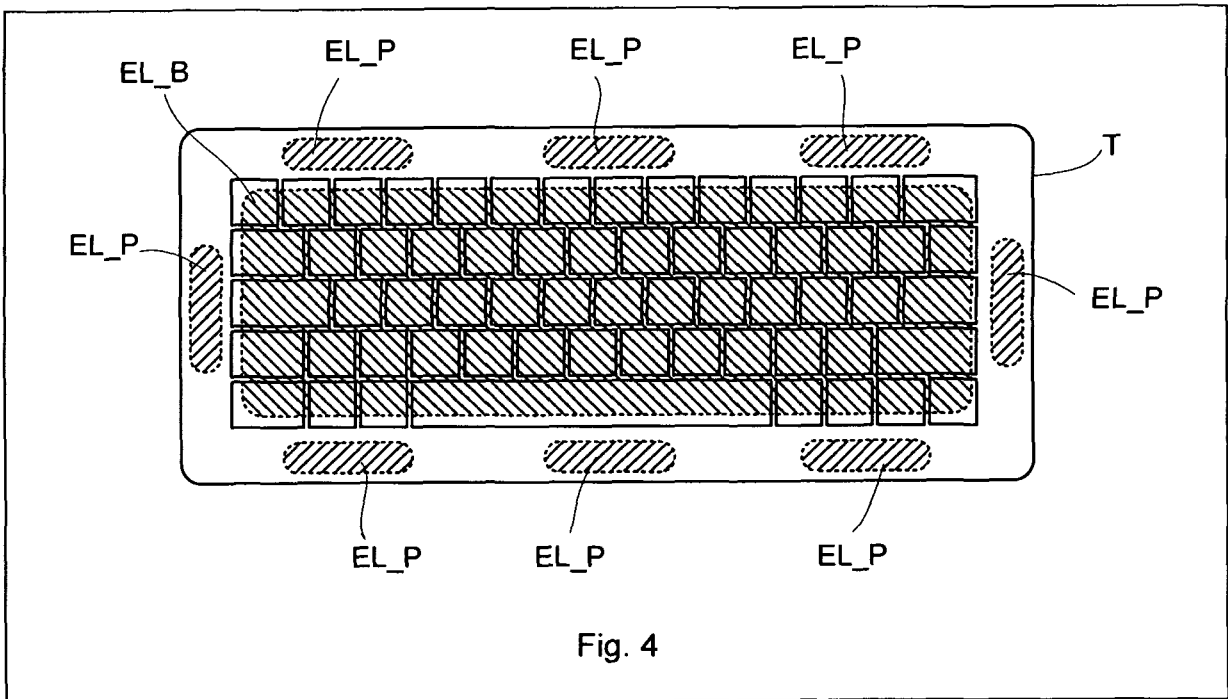
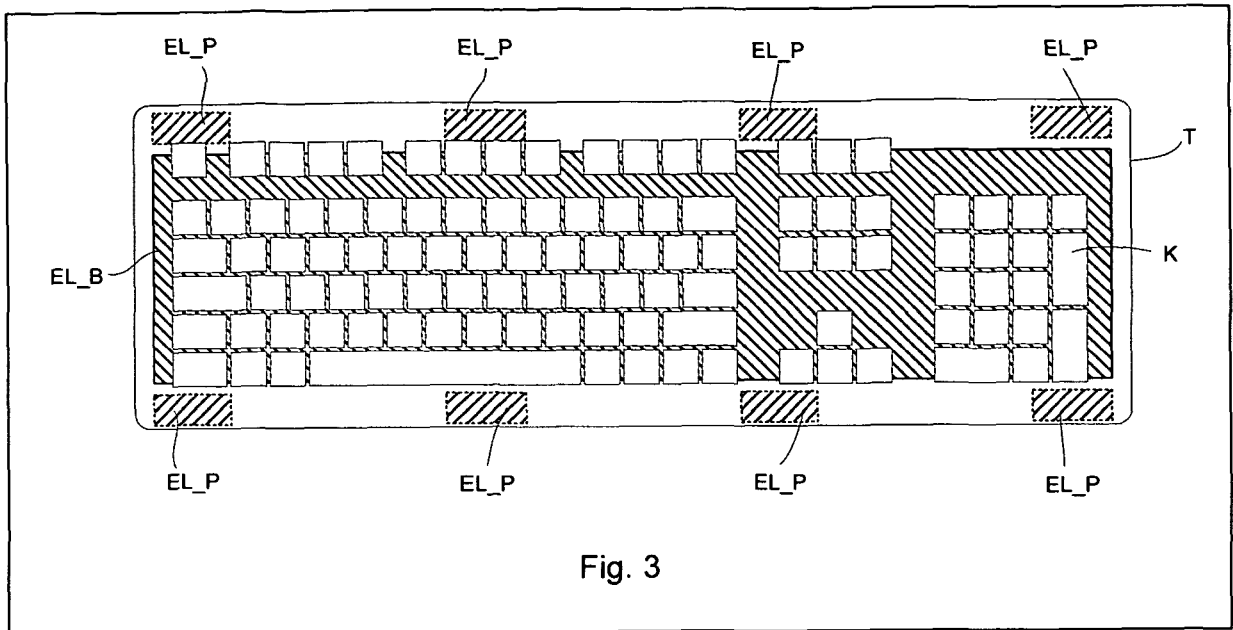

Fig. 2b



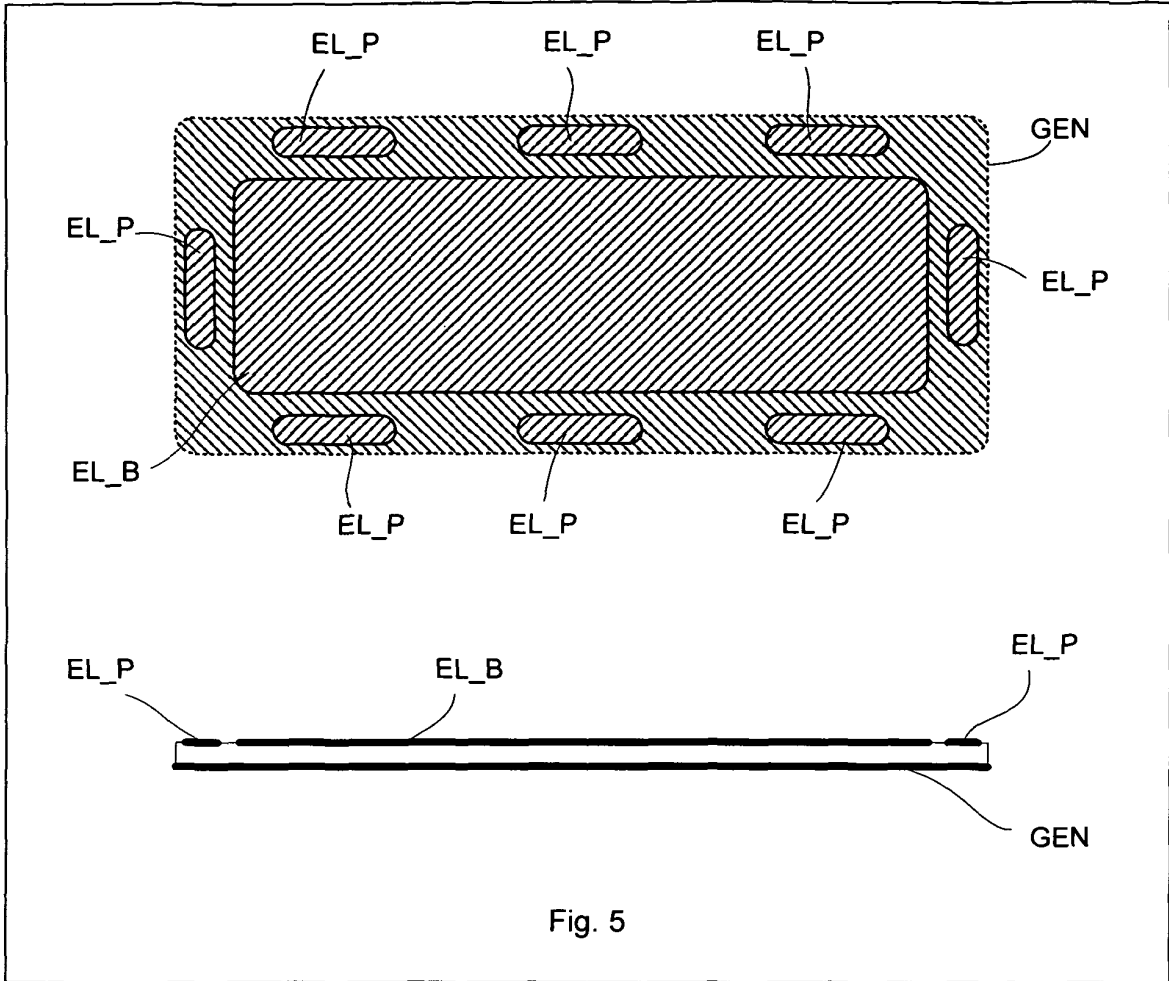

Fig. 5

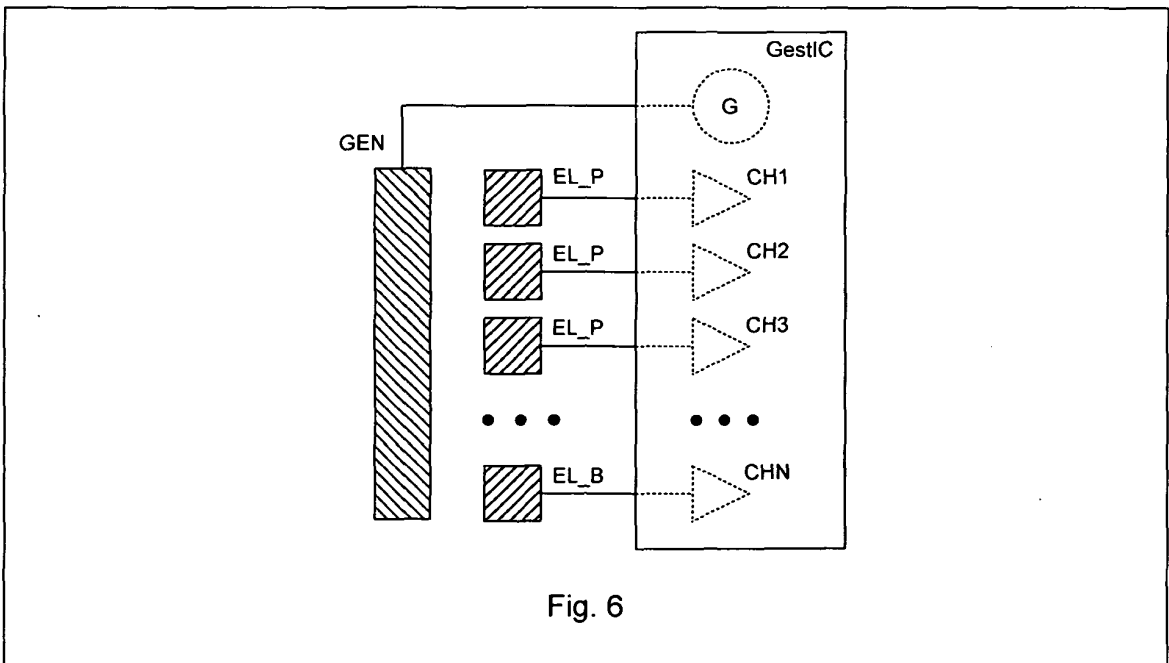

Fig. 6

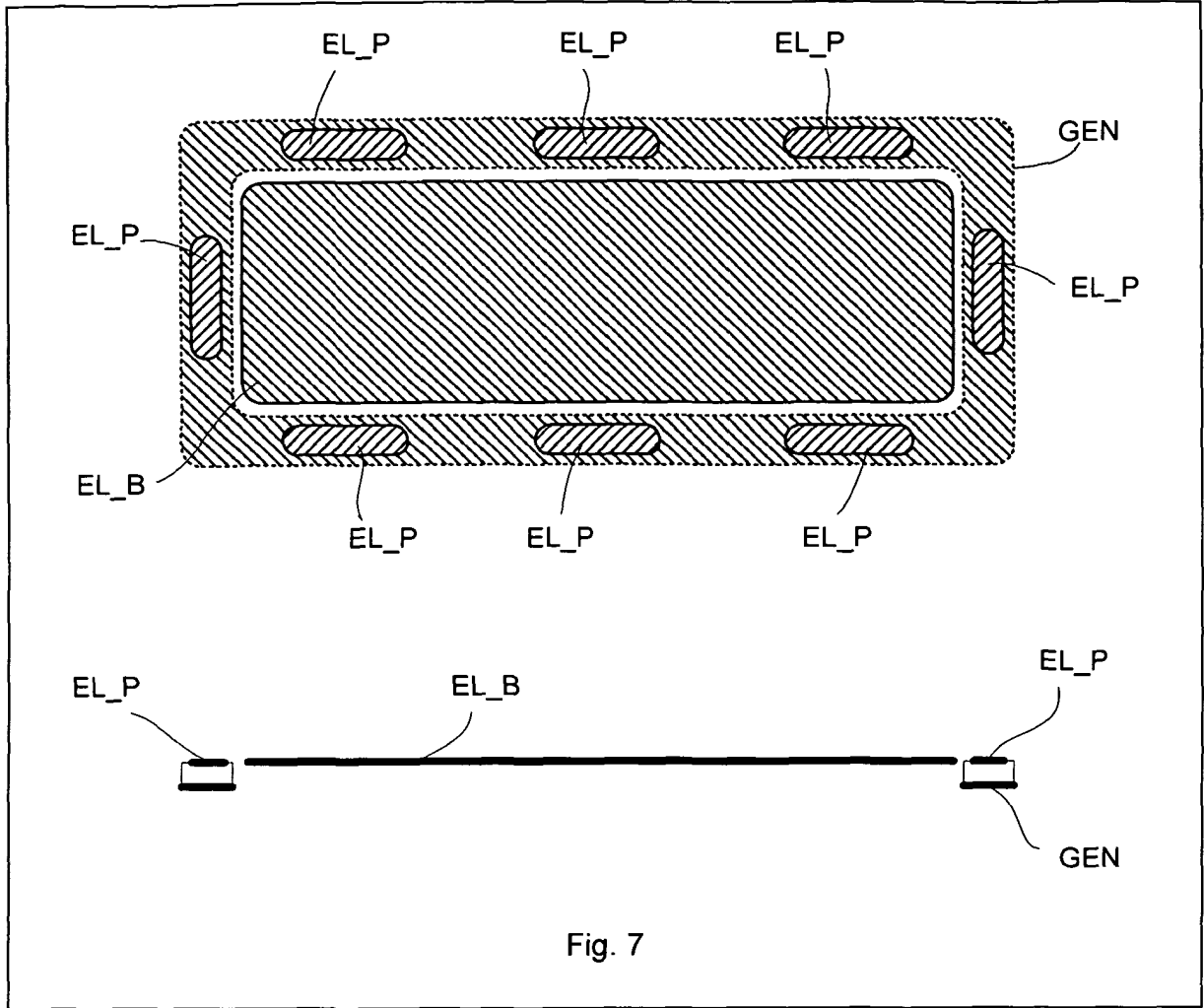

Fig. 7

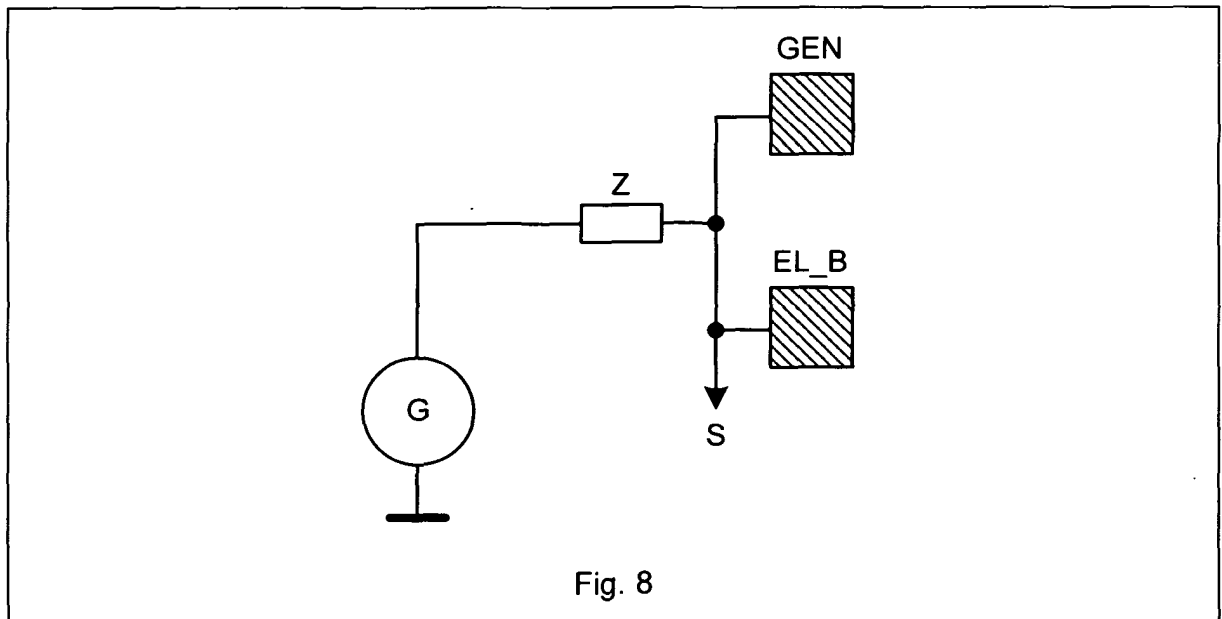

Fig. 8

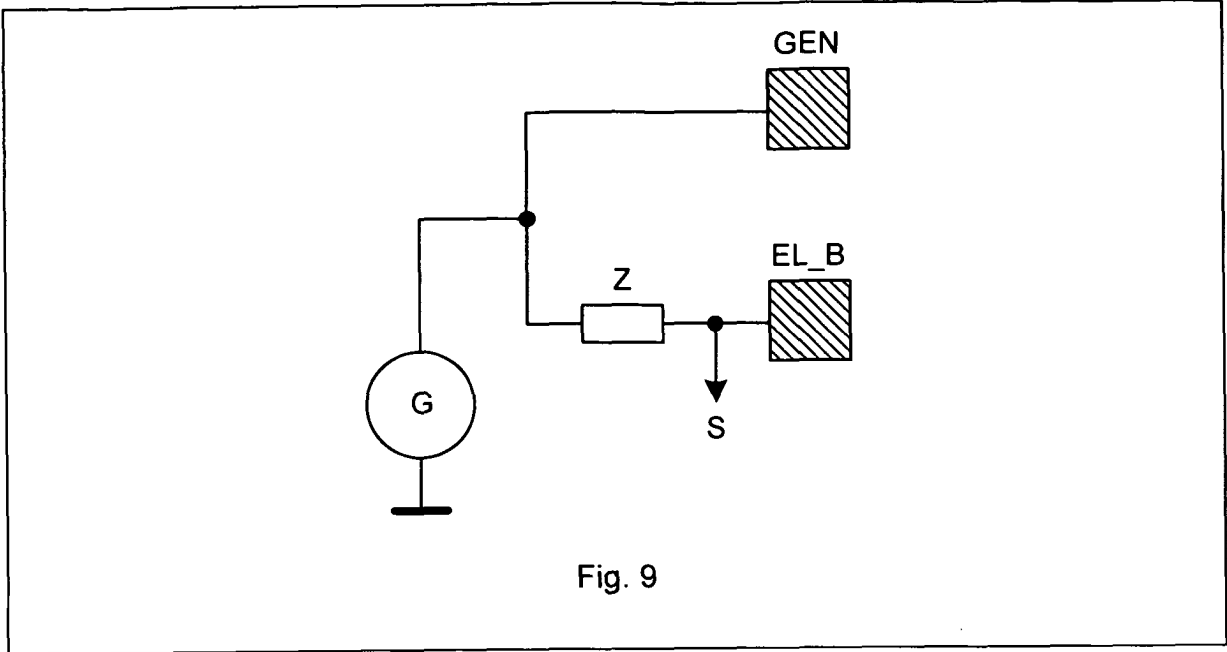

Fig. 9

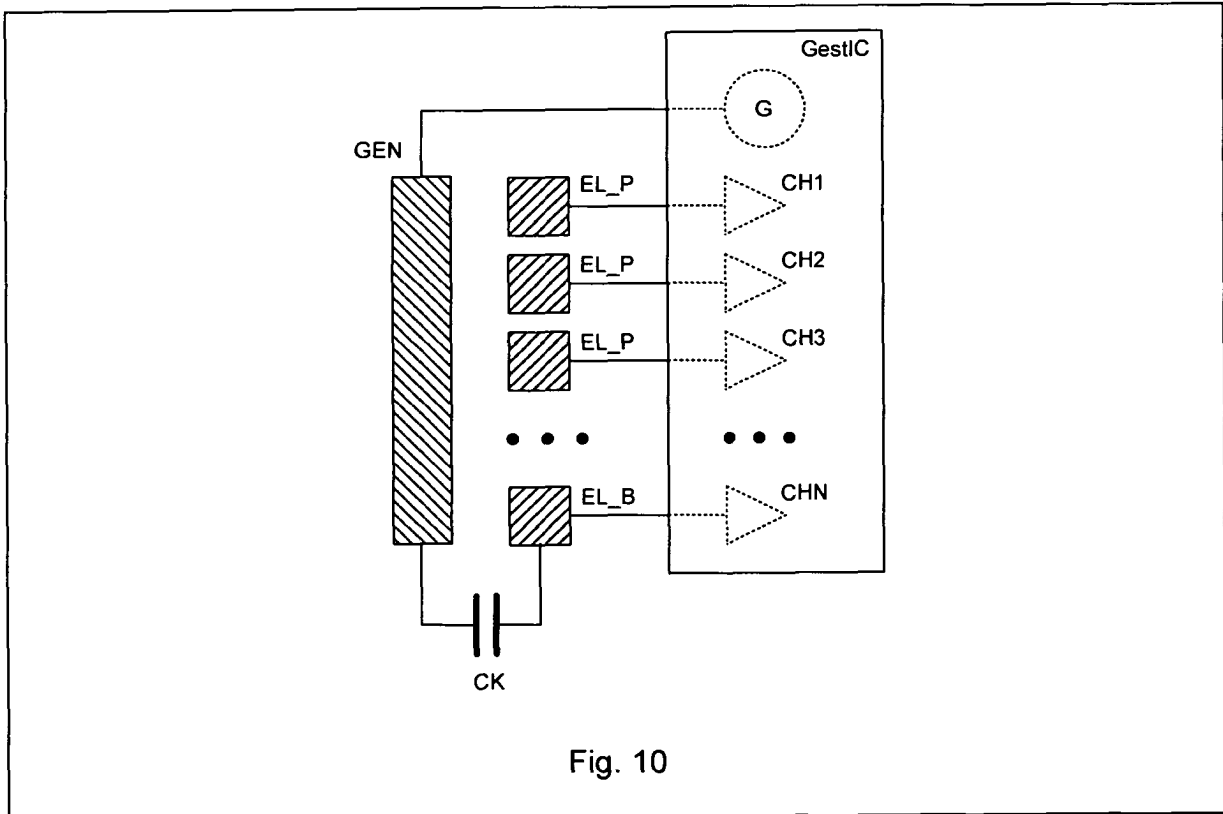

Fig. 10

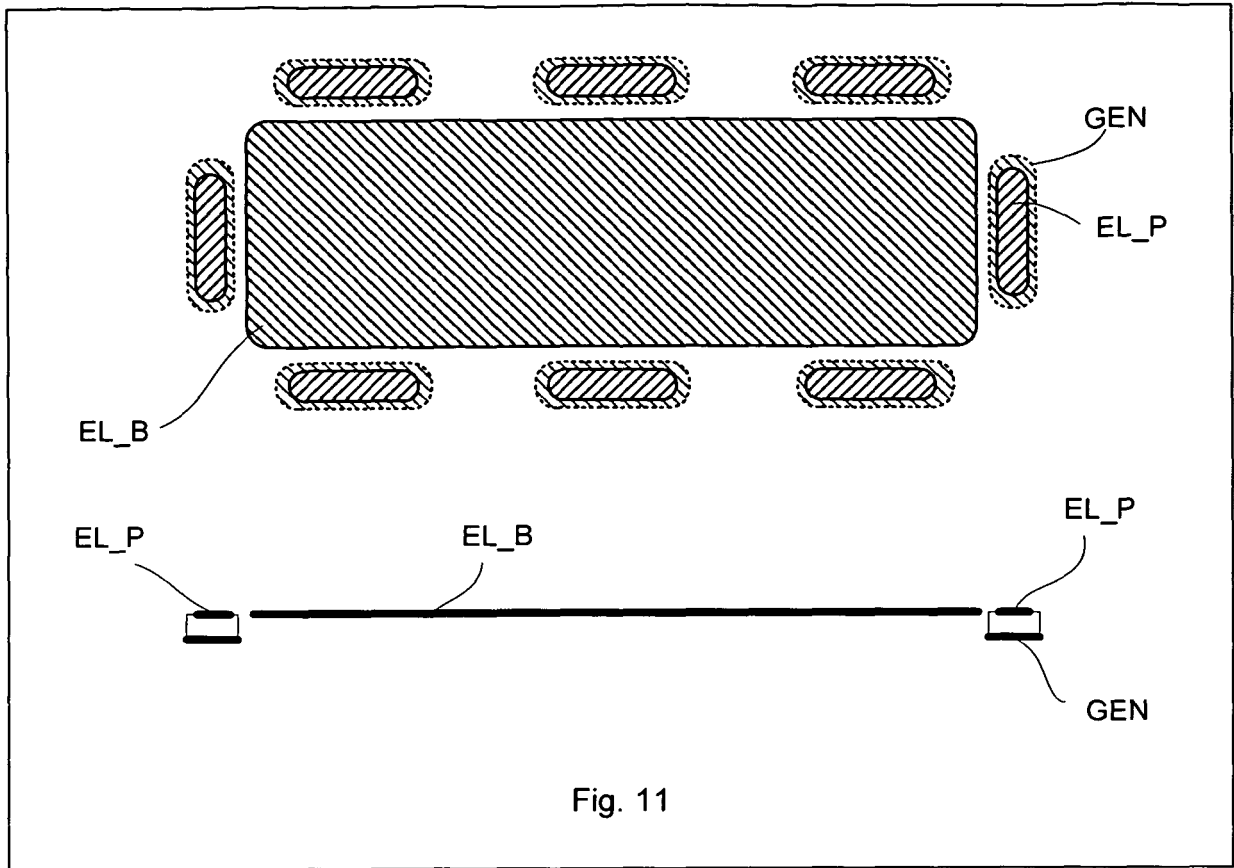

Fig. 11

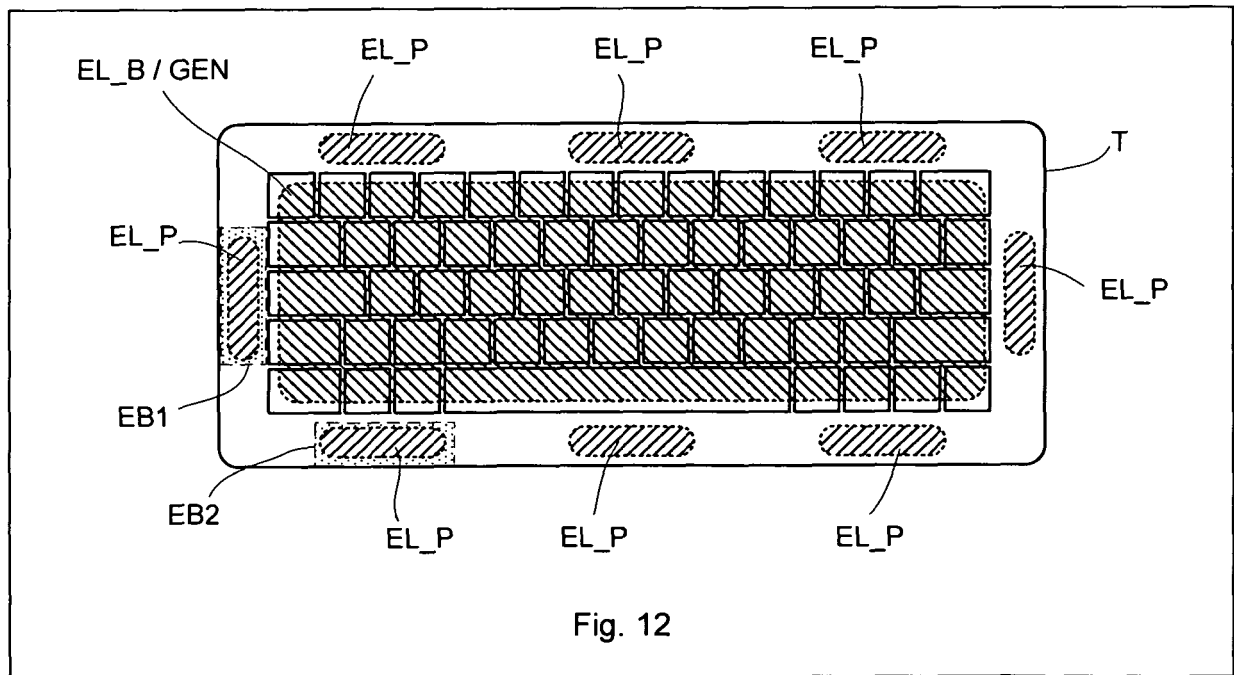

Fig. 12

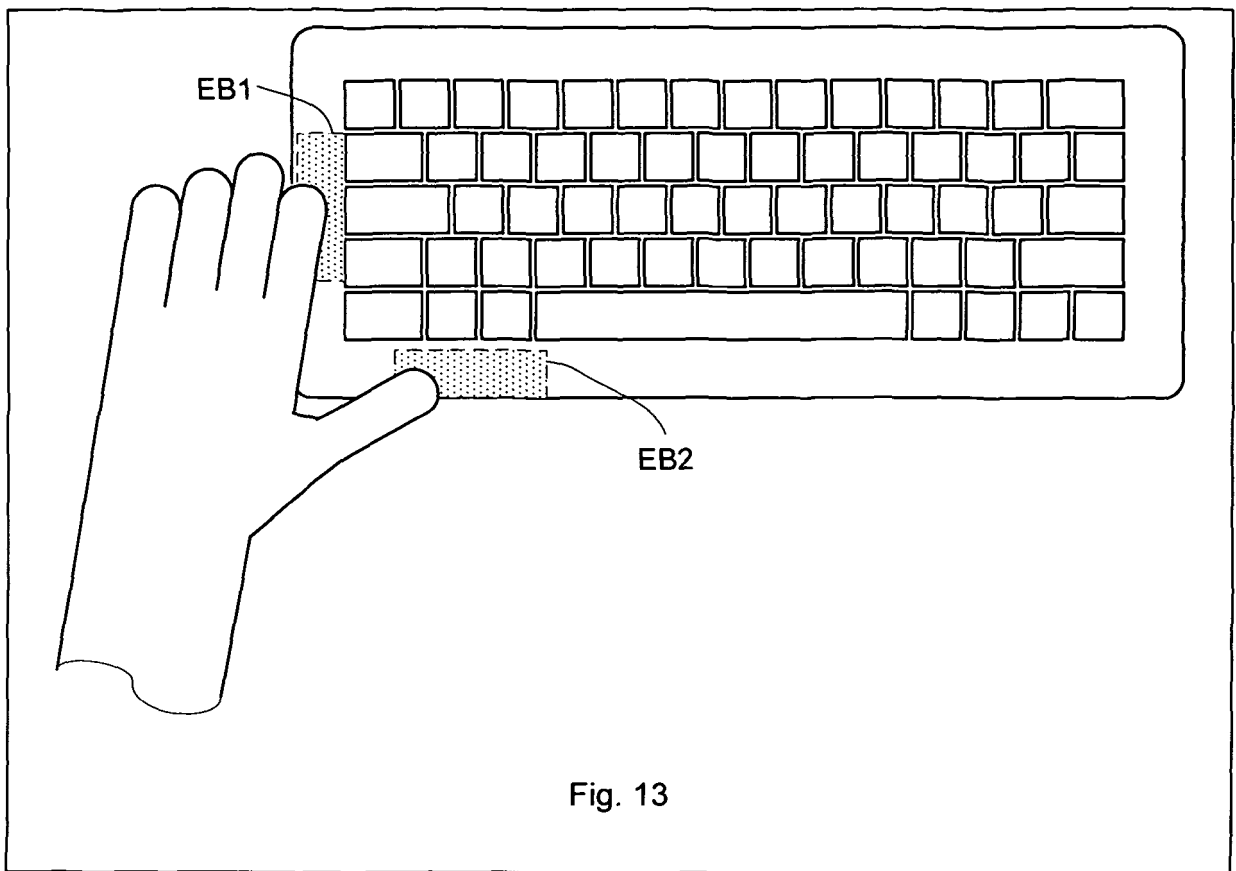

Fig. 13

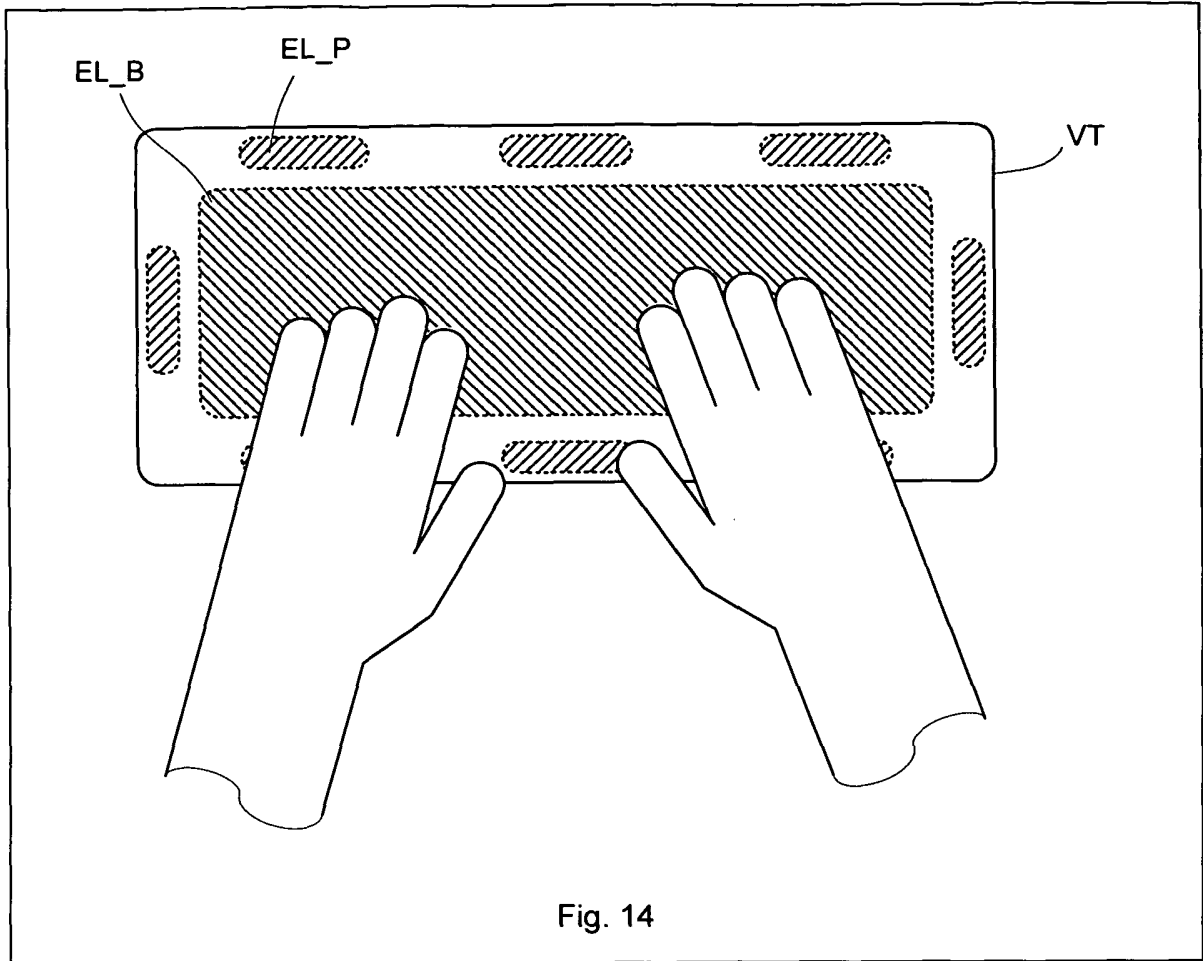

Fig. 14

REFERENCES CITED IN THE DESCRIPTION

This list of references cited by the applicant is for the reader's convenience only. It does not form part of the European patent document. Even though great care has been taken in compiling the references, errors or omissions cannot be excluded and the EPO disclaims all liability in this regard.

Patent documents cited in the description

- US 20060232567 A1 [0005]