

[54] **UNDERWATER ACOUSTICAL JAMMING APPARATUS**
 [75] Inventor: **Freeman K. Hill, Seabrook, Md.**
 [73] Assignee: **The United States of America as represented by the Secretary of the Navy, Washington, D.C.**

2,305,948	12/1942	Bachert, Sr. et al.....	102/5
2,376,227	5/1945	Brown.....	102/5
3,107,617	10/1963	Loeper et al.	102/61
3,097,600	7/1963	Hopkins et al.....	102/7
2,925,965	2/1960	Pierce.....	244/3.13

Primary Examiner—Samuel W. Engle
Attorney, Agent, or Firm—R. S. Sciascia; Q. E. Hodges

[22] Filed: **June 17, 1971**

[21] Appl. No.: **154,204**

[52] U.S. Cl. **114/20 R, 102/1 R, 102/22, 181/5 XC**

[51] Int. Cl. **F42b 19/00**

[58] Field of Search 102/1, 5, 61, 7, 22; 114/20 R; 89/1, 1.803, 1.5; 181/5 XC

[56] **References Cited**

UNITED STATES PATENTS

1,290,815	1/1919	Weaver.....	114/20 R
2,826,120	3/1958	Lang et al.....	89/1.803
1,292,668	1/1919	Weaver.....	114/20 R
2,197,129	4/1940	Leonardi, Jr.....	114/20 R

[57] **ABSTRACT**

A means for jamming underwater detection and tracking signals by sequentially dispensing and firing explosive charges in the area of track. The exploding charges produce shock waves and low intensity sound reverberations which interfere with acoustical signals directed towards the object to be tracked. The present invention particularly discloses a torpedo like device which may be launched from a submarine attempting to "break trail." The self propelled device sequentially ejects a large number of small explosive charges to provide a continuing acoustical shield which enables the submarine to maneuver beyond tracking range.

3 Claims, 4 Drawing Figures

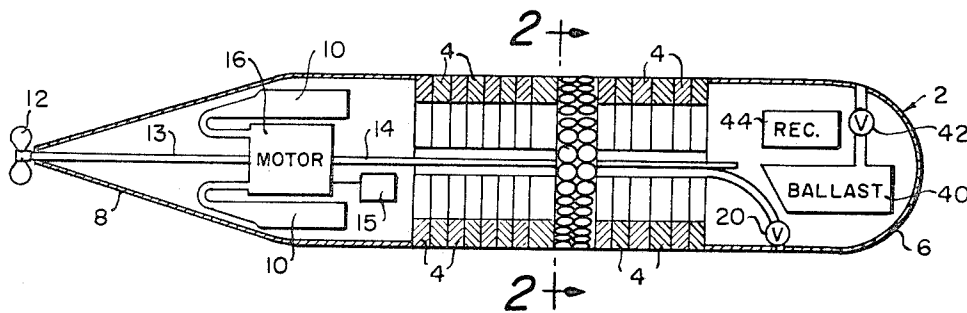

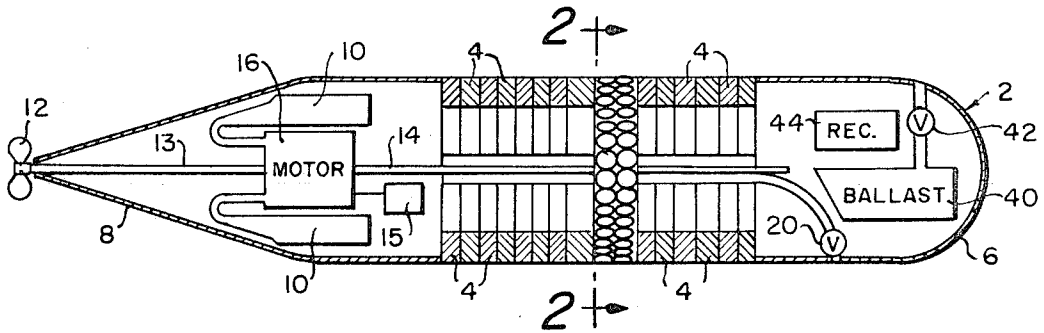

FIG. 1.

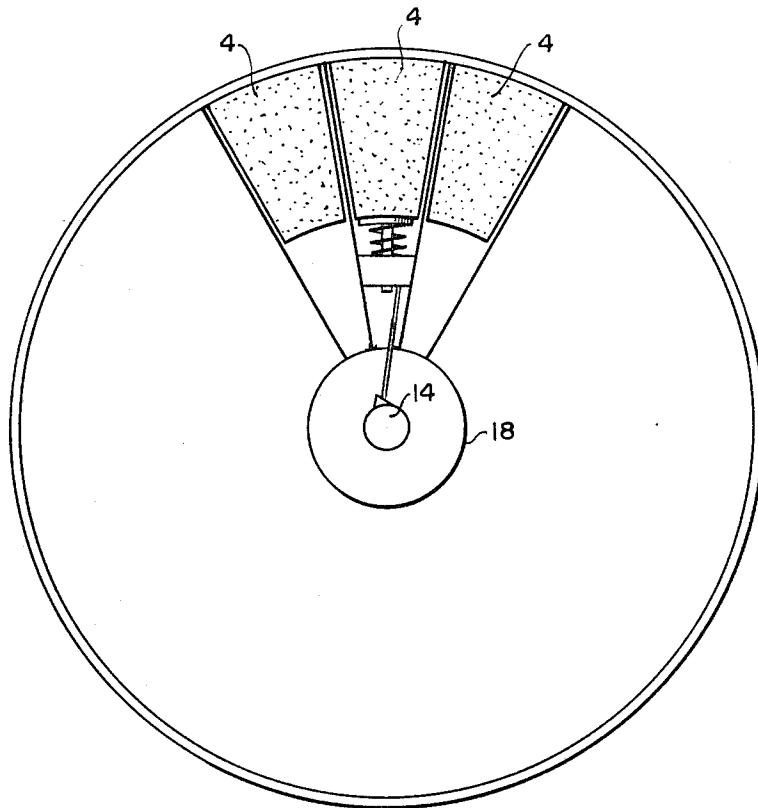

FIG. 2.

INVENTOR.
FREEMAN K. HILL
BY *JW Peterson*
AGENT
WJ Hodges
ATTORNEY

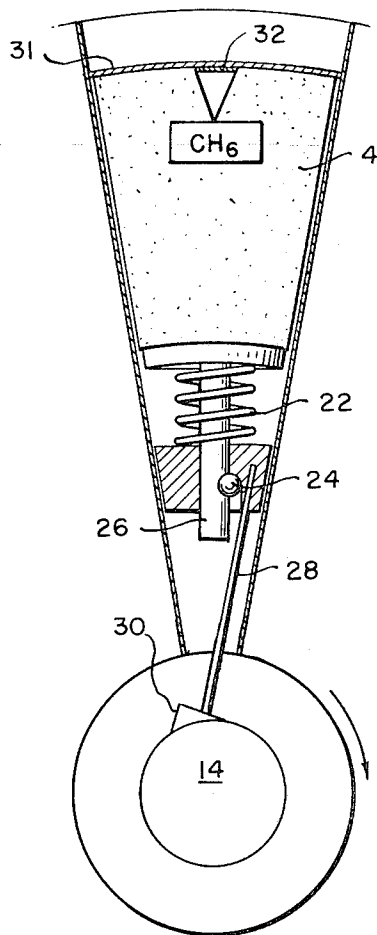

FIG. 3.

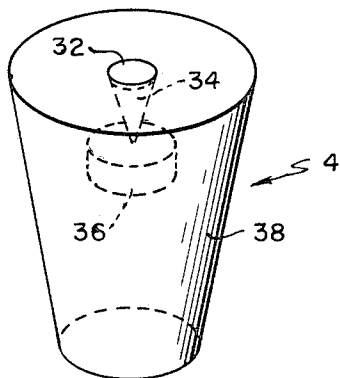

FIG. 4.

INVENTOR
FREEMAN K. HILL
BY *Jw Peterson*
AGENT
W. E. Hodges
ATTORNEY

UNDERWATER ACOUSTICAL JAMMING APPARATUS

BACKGROUND OF THE INVENTION

In the past, various devices have been used for jamming underwater detection and tracking signals. The patent to J.C. Hopkins et al., U.S. Pat. No. 3,097,600, illustrates an embodiment of an explosive underwater noise making device for masking the sound of submarine during the performance of evasion maneuvers. This explosive noise maker is adapted to be ejected from the signal tube of a submerged submarine. The present invention likewise provides an underwater noise making device. However, the present invention utilizes a self propelled torpedo capable of being wire or otherwise controlled to provide optimum shielding. Furthermore, launching of said torpedo could be accomplished from surface vessels as well as submerged submarines. The specific design of the device provides an extremely effective means of sound masking and a step forward in the art.

SUMMARY OF THE INVENTION

The invention is a method and a preferred means for jamming underwater detection and tracking signals by sequentially dispensing and firing explosive charges in the area of the track from a self propelled device.

OBJECTS OF THE INVENTION

The principle object of the invention is to provide an explosive noise maker adapted to be ejected from the torpedo tube of a submerged submarine and to fire a rapid succession of explosive charges underwater.

A further object of the invention is to provide a self propelled device which can be controlled outside the submarine for maximum efficient use.

It is still another object of the present invention to provide a device which can be launched by surface vessels as well as from submerged submarines.

Still another object of the present invention is to provide a device having independent safety mechanisms for the initiation of the explosives.

DESCRIPTION OF THE DRAWINGS

FIG. 1 is a view partially in section of the underwater acoustic jammer.

FIG. 2 shows a cross section of the device in FIG. 1, illustrating charges arranged peripherally around a detonating shaft.

FIG. 3 shows in detail the release mechanism for the charges.

FIG. 4 shows the general configuration of the explosive charge.

DESCRIPTION OF THE PREFERRED EMBODIMENT

A mechanism for jamming, interfering or suppressing of acoustic signals in the direction in tracking of submarines is proposed. Explosive charges dispersed and fired sequentially provide the jamming signals which are created by the shock wave and first bubble from the explosive charge as well as the more persistent but lower intensity sound reverberations. Device 2 is to be dispensed from the submarine which is seeking to break trail and is to be neutrally buoyant at the depth of the order of 400 feet. After launching from the submarine and seeking its proper level, the device 2 will

then eject explosive charges 4, of about 1 pound weight at specific time intervals, for instance, 2, 3, 4 . . . 10 seconds, which detonate when at a distance of the order of 400 feet from the device. The entire device 2 is approximately the size of a torpedo, having a cylindrical shape, a hemispherical head 6, and a tapered tail 8. Compressed nitrogen in containers 10 may be provided to drive the torpedo at a low speed, say approximately 3 knots by means of a shaft 13 and a propeller 12, and to rotate shaft 14 for actuating the cartridge dispenser. Nitrogen tanks 10 will be designed to fit compactly into the rear compartment of the torpedo. The tanks 10 will be piped and valved to the adjacent motor 16. The charge dispenser mechanism is shown in greater detail in FIG. 2, taken from section lines 2-2 of FIG. 1, consists of a shaft 14 driven by motor 16, which, at set intervals, ejects the individual charges 4.

FIG. 2 shows the shaft 14 surrounded by a tube 18, with 18 charges arranged peripherally around the shaft 14. The tube 18, is open to the external seawater by means of a check valve 20, at a depth of 300 feet or more or where the external water pressure is in the order of 150 psi. Valve 20 is not released until after launching the device from the submarine. When water enters the central tube 18, and contacts the underside of each charge 4, as seen in FIG. 2, the pressure on the individual charges is then equalized. A compressed spring 22 is placed beneath each charge 4, and is released by the rotating shaft 14 in sequence as is seen in more detail in FIG. 3. The release mechanism is a detent consisting of a ball 24, partially inserted in a circular hole in the shaft 26 of the spring retainer. The ball 24 is released at the proper time by the action of the push rod 28 which is forced upward by a ratcheted section 30, mounted on the rotating shaft 14. Thus, each charge is forced outward into the ocean at the prescribed time. The location of the ratcheted section 30 and the timing sequence will be adjusted to provide the most convenient rotating rate for the drive shaft 14. After ejection, the explosive charges 4, being of greater density than water, begin to sink. When they reach a preselected depth, a gold diaphragm 32 of proper thickness and scoring ruptures; this produces an adiabatic compression of the small volume of enclosed air 34. The temperature reached by this volume of air, being compressed by the incoming seawater is about 400° C. This is sufficient to ignite the 1 ounce CH₆ booster 36, enclosed in the face of the charge 4. This, in turn, detonates the main charge 38 comprised of cyclotol. An adjustment mechanism 15 is provided in the torpedo to permit altering the time between shots, i.e., from 2-10 seconds. This is done by shifting the rotation rate of the dispenser shaft 14 to correspond to the desired time interval. Motor 16 is provided to drive the two shafts 13 and 14; shaft 13 being provided to turn the propeller, shaft 14 to turn the dispenser mechanism, the motor is essentially a turbine, the vanes of which are driven by compressed nitrogen from the tanks 10, which causes the shafts 13 and 14 to turn. Shafts 13 and 14 are geared at an appropriate rate. Propeller 12 could rotate near the turning speed of the turbine motor 16, but the dispenser shaft 14 would have to be geared down to a relatively low turning rate. A pressure sensitive switch 42 will be provided to control the buoyancy of the device in order to maintain the depth near the 400 foot level. Adequate volume would be available in the head

of the torpedo to provide for buoyancy adjustment through use of ballast 40, especially when it is desired to recover the device after a test operation. Control 44 facilitates accurate guidance and possible recovery of the device. It is noted that launching of the device could be accomplished from surface vessels as well as from submerged submarines. It is noted also that a wire control (not shown) would be possible if desired. Because of: *a* the adiabatic compression feature required to initiate the charge, and *b* the water pressure provided by flooding the dispenser drive mechanism after launching, two independent safety mechanisms are provided for the initiation of the explosive. It is noted that the charges 4 are open externally to seawater pressure with the exception of a thin retaining cap 31 used to keep the charges 4 in position during routine handling. Upon rotation of the shaft 14, the retaining diaphragm 31 would give way and allow the charge 4 to exit exposing the gold diaphragm 32 to seawater as described earlier. As indicated in FIG. 4, an adiabatic compression mechanism is suggested as the primary initiator for the booster; however, an alternate mechanism including a conventional firing train could be used. Furthermore, it would be within the scope of the present invention to provide a clock mechanism (not shown) which could be included behind each charge and set to release of the spring which ejects the individual charges instead of using a rotating shaft.

It is to be understood that the invention is not limited to the exact details of construction shown and described, for obvious modifications and variations will occur to persons skilled in the art. It is therefore to be understood that within the scope of the appended claims the invention may be practiced otherwise than as specifically described.

What is claimed is:

1. An underwater acoustical jammer comprising:
 - a self-propelled tube-like carrier member;
 - an inner tube member mounted axially of said tube-like member;
 - a plurality of chambers extending radially from said inner tube member to the outer surface of said tube-like member;
 - an explosive device releasably mounted in each of said chambers;
 - means for sequentially releasing said explosive devices including a cam actuated release means;
 - means in each of said chambers for ejecting said explosive charge in a radial direction upon release;
 - means for detonating said charge subsequent to ejection;
 - said cam actuated release means including a rotatable shaft driven by the propulsion means and having a plurality of cams spaced axially along said shaft;
 - plungers successively engaged by said cams to effect the release of said explosive devices to provide substantially continuous acoustical jamming of acoustical detection and tracking systems.
2. A device as in claim 1, wherein said dispensing means further includes a chamber means surrounding said rotatable shaft, said chamber being controllably connected to seawater surrounding said capsule means so that hydrostatic forces acting on said explosive means may be balanced.
3. A device as in claim 2, wherein said dispensing means further includes ball detent locking means connected to said plunger which is released by the operation of said cam actuated release means.

* * * * *

40

45

50

55

60

65