

(19) World Intellectual Property Organization  
International Bureau



(43) International Publication Date  
24 September 2009 (24.09.2009)

(10) International Publication Number  
**WO 2009/116033 A1**

(51) International Patent Classification:

A47C 31/02 (2006.01) A47C 7/22 (2006.01)  
A47C 7/28 (2006.01) A47C 5/06 (2006.01)

(21) International Application Number:

PCT/IL2009/000297

(22) International Filing Date:

16 March 2009 (16.03.2009)

(25) Filing Language:

English

(26) Publication Language:

English

(30) Priority Data:

61/064,615 17 March 2008 (17.03.2008) US

(71) Applicant (for all designated States except US): **KETER PLASTIC LTD.** [IL/IL]; 2 Sapir Street, Industrial Area, 46852 Herzelyia (IL).

(72) Inventor; and

(75) Inventor/Applicant (for US only): **HAIMOFF, Efraim** [IL/IL]; 24 Carmel Street, 90805 Mevasereth Zion (IL).

(74) Agent: **REINHOLD COHN AND PARTNERS**; P.O. Box 13239, 61131 Tel Aviv (IL).

(81) Designated States (unless otherwise indicated, for every kind of national protection available): AE, AG, AL, AM, AO, AT, AU, AZ, BA, BB, BG, BH, BR, BW, BY, BZ, CA, CH, CN, CO, CR, CU, CZ, DE, DK, DM, DO, DZ,

EC, EE, EG, ES, FI, GB, GD, GE, GH, GM, GT, HN, HR, HU, ID, IL, IN, IS, JP, KE, KG, KM, KN, KP, KR, KZ, LA, LC, LK, LR, LS, LT, LU, LY, MA, MD, ME, MG, MK, MN, MW, MX, MY, MZ, NA, NG, NI, NO, NZ, OM, PG, PH, PL, PT, RO, RS, RU, SC, SD, SE, SG, SK, SL, SM, ST, SV, SY, TJ, TM, TN, TR, TT, TZ, UA, UG, US, UZ, VC, VN, ZA, ZM, ZW.

(84) Designated States (unless otherwise indicated, for every kind of regional protection available): ARIPO (BW, GH, GM, KE, LS, MW, MZ, NA, SD, SL, SZ, TZ, UG, ZM, ZW), Eurasian (AM, AZ, BY, KG, KZ, MD, RU, TJ, TM), European (AT, BE, BG, CH, CY, CZ, DE, DK, EE, ES, FI, FR, GB, GR, HR, HU, IE, IS, IT, LT, LU, LV, MC, MK, MT, NL, NO, PL, PT, RO, SE, SI, SK, TR), OAPI (BF, BJ, CF, CG, CI, CM, GA, GN, GQ, GW, ML, MR, NE, SN, TD, TG).

Declarations under Rule 4.17:

— of inventorship (Rule 4.17(iv))

Published:

— with international search report (Art. 21(3))

— before the expiration of the time limit for amending the claims and to be republished in the event of receipt of amendments (Rule 48.2(h))

(54) Title: ARTICLE OF FURNITURE AND ATTACHMENT MECHANISM THEREFOR

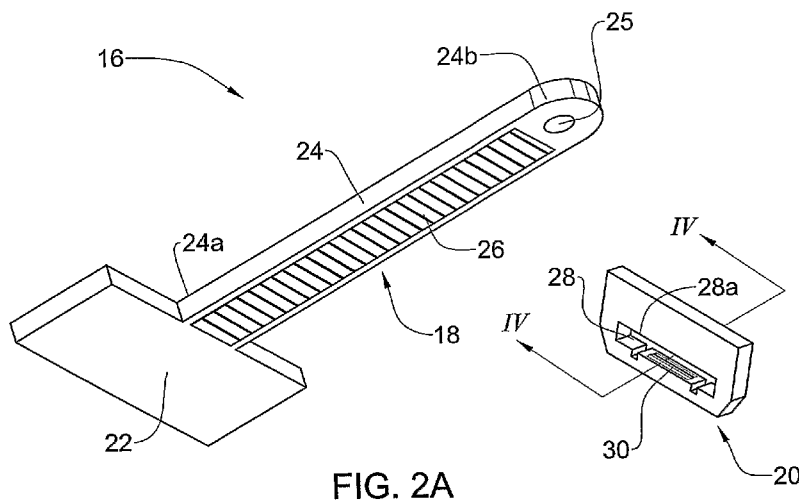

FIG. 2A

(57) Abstract: An article of furniture (10) is provided comprising a frame (12), at least one support portion (14) attached thereto, and a plurality of attachment mechanisms (16) therebetween. Each of the attachment mechanisms (16) comprises a first attachment element (18) fixed to one of the frame (12) and support portion (14), and a second attachment element (20) fixed to the other of the frame (12) and support portion (14) at a position corresponding to that of the first attachment element (18). The second attachment element (20) is designed to restrain the first attachment element (18) at a desired position relative thereto so as to resist disengagement of the first attachment element (18) therefrom.

WO 2009/116033 A1

## ARTICLE OF FURNITURE AND ATTACHMENT MECHANISM THEREFOR

### FIELD OF THE INVENTION

This invention relates to articles of furniture, and in particular to arrangements for attaching and tensioning support portions of furniture to a frame thereof.

### BACKGROUND OF THE INVENTION

5 Articles of furniture, in particular those designed to bear upon them a person and/or an object, are often made with a support portion (i.e., for supporting the person and/or object) attached to a frame. Many different means have been designed for performing this attachment.

US 3,512,834 discloses a chair formed of aluminum or similar material for a frame member, and ends of webbing strips or lengths are retained in an operative position by either a single retaining member cooperating with and securing an end of each strip of flexible webbing material or a single retaining member cooperating with and simultaneously securing all of the ends of the webbing material strips to an aluminum frame member.

US 5,015,034 discloses an upholstery system for a vehicle accessory including a substrate with a U-shaped channel adjacent an edge and including a lip extending from one wall. A trim member includes spaced locking tabs which underlie the lip for compressibly holding an edge of upholstery material in the channel. In one embodiment, pins in the trim ring extend through the material and into apertures in an outer flange of the channel. In another embodiment, the locking tabs are formed on the substrate and the trim member includes interengaging locking slots.

20 US 5,662,383 discloses a chair assembly including a frame defining a channel and a deflectable wall, a retainer receivable by the channel and engageable with the deflectable wall, and a web of fabric located in the channel and engageable with the retainer.

US 6,540,950 discloses an attachment structure for a load bearing fabric. The attachment structure includes an expandable carrier secured to an unstretched load bearing fabric. To attach the carrier to the frame, the carrier and fabric are stretched together to desired shape and secured to a support frame.

25 US 5,338,091 discloses webbing attached to a furniture frame by a hem and welting, which are laid in a channel and locked in with a strip that is slipped under the webbing and into the channel. This arrangement also holds the locking strip in place. The strip is removable so the

- 2 -

the channel. This arrangement also holds the locking strip in place. The strip is removable so the webbing can be cleaned or replaced. The channel can be formed by welding flexible stock to a steel frame of any shape.

US 2001/0030453 discloses a backrest for a chair comprising a frame, a membrane, and a back support member. The membrane, at least a portion of which is transparent, is attached to the frame and has a first body-contacting surface and an opposite second surface. The back support member is attached to the frame and has a support surface. At least a portion of the support surface contacts the second surface of the membrane, and at least a portion of the back support member is visible through the membrane from the first body-contacting surface thereof.

Furthermore, it discloses a backrest for a chair comprising a frame having a pair of side members, wherein each of the side members has a lower section and an upper section. The upper section extends rearwardly and outwardly from the lower section so as to form a bowed section therewith. A flexible membrane is attached to and extends between the side members, and has a bowed section corresponding to the bowed section of the side members. The membrane has a first body-contacting surface and an opposite second surface.

## SUMMARY OF THE INVENTION

According to one aspect of the present invention, there is provided an article of furniture comprising a frame, at least one support portion attached thereto, and a plurality of attachment mechanisms therebetween, each of the attachment mechanisms comprising a first attachment element fixed to one of the frame and support portion, and a second attachment element fixed to the other of the frame and support portion at a position corresponding to that of the first attachment element, the second attachment element being designed to restrain the first attachment element at a desired position relative thereto so as to resist disengagement of the first attachment element therefrom.

The article may be designed such that:

- the first attachment element comprises a longitudinally extending fastening member comprising a first fastening arrangement; and
  - the second attachment element comprises a receiving aperture designed to receive therein the fastening member, and a second fastening arrangement;
- the first and second fastening arrangements being mutually configured for the restraining.

The second fastening arrangement may be at least partially disposed within the receiving aperture.

- 3 -

The first fastening arrangement may comprise a plurality of longitudinally spaced first engagement elements, with the second fastening arrangement comprising at least one second engagement element, the first and second engagement elements being mutually configured for the restraining.

5 Each of the first engagement elements may be formed as a saw-tooth, with a leading surface thereof being formed at an first angle with respect to the fastening member, and a trailing surface being formed at a second angle substantially perpendicular thereto; the second engagement element being formed as a saw-tooth, with a leading surface thereof, configured to face the leading surface of the first engagement element, being formed at an angle corresponding  
10 to the first angle. The first angle may be less than  $40^\circ$ , in particular about  $30^\circ$ .

The second attachment element may comprise a disengagement mechanism configured to release the first and second fastening arrangements from one another to facilitate disengagement of the first attachment element therefrom.

15 The disengagement mechanism may comprise a spring element adapted to bias the second fastening arrangement toward the first fastening arrangement when the fastening member is received within the receiving aperture so as to facilitate the restraining, and to allow the second fastening arrangement to be selectively displaced away from the first fastening arrangement to facilitate the disengagement.

20 The disengagement mechanism is formed as a cantilevered member, which may constitute the spring element, the second fastening arrangement being formed thereupon.

The disengagement mechanism may further comprise a spring disposed below (i.e., on the side opposite that of the second fastening arrangement) the cantilevered member.

The first and second attachment elements may be made of a plastic material.

25 At least one of the first and second attachment elements may be formed integrally with the frame and/or support portion.

At least one of the frame and support portion may comprise receptacles configured to receive one of the first and second attachment elements.

The frame may comprise at least one of each of the first and second attachment elements.

30 The article may be selected from the group comprising a chair (including chaise lounges, etc.), a sofa, a cot, a bed, and a table.

In the event that the article is a chair or a sofa, or any other similar article of furniture, the support portion may be selected from the group comprising a backrest and a seat.

- 4 -

According to another aspect of the present invention, there is provided an attachment mechanism for connecting a frame and a support portion of an article of furniture, the attachment mechanism comprising a first attachment element configured to be fixed to one of the frame and support portion, and a second attachment element configured to be fixed to the other of the frame and support portion at a position corresponding to that of the first attachment element, the second attachment element being designed to restrain the first attachment element at a desired position relative thereto so as to resist disengagement of the first attachment element therefrom.

The article may be designed such that:

- the first attachment element comprises a longitudinally extending fastening member comprising a first fastening arrangement; and
- the second attachment element comprises a receiving aperture designed to receive therein the fastening member, and a second fastening arrangement;

the first and second fastening arrangements being mutually configured for the restraining.

The second fastening arrangement may be at least partially disposed within the receiving aperture.

The first fastening arrangement may comprise a plurality of longitudinally spaced first engagement elements, with the second fastening arrangement comprising at least one second engagement element, the first and second engagement elements being mutually configured for the restraining.

Each of the first engagement elements may be formed as a saw-tooth, with a leading surface thereof being formed at an first angle with respect to the fastening member, and a trailing surface being formed at a second angle substantially perpendicular thereto; the second engagement element being formed as a saw-tooth, with a leading surface thereof, configured to face the leading surface of the first engagement element, being formed at an angle corresponding to the first angle. The first angle may be less than 40°, in particular about 30°.

The second attachment element may comprise a disengagement mechanism configured to release the first and second fastening arrangements from one another to facilitate disengagement of the first attachment element therefrom.

The disengagement mechanism may comprise a spring element adapted to bias the second fastening arrangement toward the first fastening arrangement when the fastening member is received within the receiving aperture so as to facilitate the restraining, and to allow the second fastening arrangement to be selectively displaced away from the first fastening arrangement to facilitate the disengagement.

- 5 -

The disengagement mechanism is formed as a cantilevered member, which may constitute the spring element, the second fastening arrangement being formed thereupon.

The disengagement mechanism may further comprise a spring disposed below (i.e., on the side opposite that of the second fastening arrangement) the cantilevered member.

5 The first and second attachment elements may be made of a plastic material.

At least one of the first and second attachment elements may be formed integrally with the frame and/or support portion.

### BRIEF DESCRIPTION OF THE DRAWINGS

10 In order to understand the invention and to see how it may be carried out in practice, an embodiment will now be described, by way of a non-limiting example only, with reference to the accompanying drawings, in which:

**Fig. 1A** is perspective view of an article of furniture according to the present invention;

**Fig. 1B** is a close-up bottom view of the interface between a frame and a support portion of the article of furniture illustrated in Fig. 1A;

15 **Fig. 2A** is a bottom perspective view of a first attachment element and a top perspective view of a second attachment element of an attachment mechanism of the article of furniture illustrated in Figs. 1A and 1B;

**Fig. 2B** is a top perspective view of the first and second attachment elements illustrated in Fig. 2A engaged with one another;

20 **Fig. 3** is a partial cross-sectional view taken along line III-III in Fig. 2B;

**Figs. 4A** and **4B** are cross-sectional views taken along line IV-IV in Fig. 2A, according to different examples.

### DETAILED DESCRIPTION OF EMBODIMENTS

25 As illustrated in Fig. 1A, there is provided an article of furniture, which is generally indicated at **10**, comprising a frame **12** carrying one or more support portions **14** designed to support a person or object resting on the article. Although the article **10** illustrated in Fig. 1A is a chair, it will be appreciated that any similar article may be provided, for example a sofa, a cot, a bed, a table, etc., without deviating from the spirit and the scope of the present invention, *mutatis mutandis*.

30 As illustrated in Fig. 1B, there are provided a plurality of attachment mechanisms, which are generally indicated at **16**, fixed to the frame **12** and to corresponding locations on the support

- 6 -

portion 14, and spanning therebetween. The attachment mechanisms 16 facilitate attachment of the frame 12 to the support portion 14, and also allow for providing a desired level of tension therebetween.

As illustrated in Fig. 2, each of the attachment mechanisms 16 comprise a first attachment element 18, and a second attachment element 20, which is adapted to restrain the first attachment element at a desired position relative thereto, so as to resist disengagement of the first attachment element therefrom. By adjusting the distance between the first and second attachment elements 18, 20 from one another, the plurality of attachment mechanisms 16 can be used to adjust the tension applied to the edges of the support portion 14, and thus be used to determine its tautness, etc, for example as per a user's requirements.

The first attachment element 18 may be formed as a single integral element, and comprises a first anchoring portion 22 designed to anchor the first attachment element to the frame 12 of the article 10, and an fastening member 24 having a proximal end 24a attached to the anchoring portion and a distal end 24b opposite thereto, and extending longitudinally therefrom for fastening to the second attachment element 20. The fastening member 24 is formed with a first fastening arrangement 26, which will be described herein below. In addition, the fastening member comprises a gripping portion 25 at its distal end 24b, designed to facilitate gripping thereof by a user. The gripping portion may be a through-going hole as illustrated, knurling, or any other appropriate design.

The second attachment element 20 is designed to be anchored to the support portion 14 of the article 10, and comprises a receiving aperture 28 which is designed to receive therein the fastening member 24 of the first attachment element 18 when inserted via an insertion opening 28a thereof. In addition, the second attachment element 20 is provided with a second fastening arrangement 30, which will be described herein below, and which is at least partially disposed within the receiving aperture and located to as to engage the first fastening arrangement 26 when the fastening member 24 is received within the receiving aperture 28.

The first and second fastening arrangements 26, 30 are mutually configured to facilitate the restraining of the first attachment element 18 at a desired position relative to the second attachment element 20, so as to resist disengagement of the first attachment element therefrom as described above. As such, and as illustrated in Fig. 3, the first fastening arrangement 26 comprises a plurality of first engagement elements 32 longitudinally arranged on the fastening member 24 and longitudinally spaced from one another. The second fastening arrangement 30

- 7 -

comprises at least one second engagement element **34** mutually configured for facilitating the restraining as described above.

The first and second engagement elements **32, 34** are formed as saw-teeth, i.e., protrusions having a generally triangular profile. Each engagement element **32, 34** comprises a leading surface **36, 38** which is formed at an acute angle  $\alpha$  (for example, below  $40^\circ$ , or more particularly  $30^\circ$ ) to its respective fastening arrangement **26, 30**, and a trailing surface **40, 42** which is formed at an angle  $\beta$  which is substantially perpendicular (for example exceeding about  $80^\circ$ ) to its respective fastening arrangement. The leading surfaces **36, 38** should be formed at similar angles to one another and disposed so as to face one another when the distal end **24b** of the fastening member **24** is inserted into the insertion opening **28a** of the receiving aperture **28**.

The angle  $\alpha$  should be chosen such that it when the distal end **24b** of the fastening member **24** is inserted into the insertion opening **28a** of the receiving aperture **28** and advanced distally therein, the first and second engagement elements **32, 34** easily slide past one another and do not substantially hinder the advancement. The angle  $\beta$  should be chosen such that when the trailing surfaces **40, 42** of the first and second engagement elements **32, 34** bear upon one another, proximal movement of the fastening member **24** within the receiving aperture **28** is hindered. (It will be appreciated that while adjacent surfaces are illustrated in Fig. 3 as being separated by a small gap, this is done for illustrative purposes only, and in fact adjacent surfaces may contact and/or bear upon one another.)

As illustrated in Figs. 4A and 4B, the second attachment element **20** may further comprise a disengagement mechanism **44**, configured to release the first and second fastening arrangements **26, 30** from one another in order to facilitate disengagement of the first attachment element **18** from the second attachment element.

As illustrated in Fig. 4A, the disengagement mechanism **44** may comprise a spring element, for example in the form of a cantilevered member **46**, which carries the second fastening arrangement **30** thereupon, e.g., the second fastening arrangement may be formed on the cantilevered member. The cantilevered member **46** is designed to bias the second fastening arrangement **30** toward the first fastening arrangement **26** when the fastening member **24** is received within the receiving aperture **28**.

Alternatively, as illustrated in Fig. 4B, a separate spring **48**, constituting the spring element, may be provided below the cantilevered member **46** (i.e., on a side opposite the second fastening arrangement **30**), so as to bias the second fastening arrangement as described above. In this case, the cantilevered member **46** does not have to exhibit any spring characteristics by

- 8 -

itself, i.e., it need not be adapted to bias the second fastening arrangement 30 at all. In this case, the cantilevered member may be hingedly attached to the second attachment element 20. Although a spring 48 in the form of a helical spring is illustrated in Fig. 4B, it will be appreciated that any appropriate spring, e.g., a torsion or a volute spring, may be used without departing from the spirit and scope of the present invention, *mutatis mutandis*.

According to either one of the examples of the disengagement mechanism 44 illustrated in Figs. 4A and 4B, when the fastening member 24 is received within the receiving aperture 28, and restrained therein as described above, it may be released therefrom by activating the disengagement mechanism. Specifically, the cantilevered member 46 is displaced such that the second fastening arrangement 30 is displaced away from the first fastening arrangement 26, thus disengaging them from one another, and allowing the fastening member 24 to be advanced proximally within the receiving aperture 28. When the cantilevered member 46 is released, it is biased back into its original position by the spring element (i.e., by the cantilevered member 46 by itself or by the spring 48) such that the second fastening arrangement 30 engages the first fastening arrangement 26, hindering the proximal advancement of the fastening member 24 within the receiving aperture 28.

The first and second attachment elements 18, 20 may be formed integrally with the frame 12 and support portion 14, respectively, or one or both may be formed separately therefrom. It will further be appreciated that within a single article 10, some of the first and/or second attachment elements 18, 20 may be formed separately from the frame 12 and support portion 14, and some may be formed integrally therewith. The frame 12 and/or support portion 14 may be formed with appropriate receptacles (for example as indicated at 50 in Fig. 1B) to receive therein its respective attachment element.

The attachment mechanisms 16 may be made of any appropriate material, for example plastic, which is semi-flexible, i.e., flexible enough to allow for the necessary manipulation to install and use it, and rigid enough so that it won't be easily displaced once installed.

Those skilled in the art to which this invention pertains will readily appreciate that numerous changes, variations and modifications can be made without departing from the scope of the invention *mutatis mutandis*. For example, while the example presented herein discloses anchoring of the first attachment element 18 to the frame 12, and of the second attachment element 20 to the support portion 14, the first attachment element may be designed to be anchored to the support portion, and the second attachment element to the frame, without departing from the spirit and scope of the present invention, *mutatis mutandis*.

**CLAIMS:**

1. An article of furniture comprising a frame, at least one support portion attached thereto, and a plurality of attachment mechanisms therebetween, each of said attachment mechanisms comprising a first attachment element fixed to one of said frame and support portion, and a  
5 second attachment element fixed to the other of said frame and support portion at a position corresponding to that of the first attachment element, said second attachment element being designed to restrain said first attachment element at a desired position relative thereto so as to resist disengagement of the first attachment element therefrom.
2. An article according to Claim 1, wherein:  
10
  - said first attachment element comprises a longitudinally extending fastening member comprising a first fastening arrangement; and
  - said second attachment element comprises a receiving aperture designed to receive therein said fastening member, and a second fastening arrangement;said first and second fastening arrangements being mutually configured for the restraining.
- 15 3. An article according to Claim 2, wherein said second fastening arrangement is at least partially disposed within said receiving aperture.
4. An article according to any one of Claims 2 and 3, wherein said first fastening arrangement comprises a plurality of longitudinally spaced first engagement elements, and said second fastening arrangement comprises at least one second engagement element, said first and  
20 second engagement elements being mutually configured for the restraining.
5. An article according to Claim 4, each of said first engagement elements being formed as a saw-tooth, with a leading surface thereof being formed at a first angle with respect to the fastening member, and a trailing surface being formed at a second angle substantially perpendicular thereto; said second engagement element being formed as a saw-tooth, with a  
25 leading surface thereof, configured to face the leading surface of the first engagement element, being formed at an angle corresponding to said first angle.
6. An article according to Claim 5, wherein said first angle does not exceed 40°.
7. An article according to Claim 6, wherein said first angle is about 30°.
8. An article according to any one of Claims 2 through 7, said second attachment element  
30 comprising a disengagement mechanism configured to release said first and second fastening arrangements from one another to facilitate disengagement of the first attachment element therefrom.

- 10 -

9. An article according to Claim 8, said disengagement mechanism comprising a spring element adapted to bias said second fastening arrangement toward said first fastening arrangement when said fastening member is received within said receiving aperture so as to facilitate the restraining, and to allow said second fastening arrangement to be selectively displaced away from said first fastening arrangement to facilitate the disengagement.
10. An article according to Claim 9, wherein said disengagement mechanism is formed as a cantilevered member, said second fastening arrangement being formed thereupon.
11. An article according to Claim 10, said cantilevered member constituting said spring element.
12. An article according to any one of Claims 10 and 11, said disengagement mechanism further comprising a spring disposed below said cantilevered member.
13. An article according to any one of the preceding claims, wherein said first and second attachment elements are made of a plastic material.
14. An article according to any one of the preceding claims, wherein at least one of said first and second attachment elements are formed integrally with the frame and/or support portion.
15. An article according to any one of Claims 1 through 13, at least one of said frame and support portion comprising receptacles configured to receive one of the first and second attachment elements.
16. An article according to any one of the preceding claims, wherein said frame comprises at least one of each of the first and second attachment elements.
17. An article according to any one of the preceding claims, being selected from the group comprising a chair, a sofa, a cot, a bed, and a table.
18. An article according to Claim 17, being selected from the group comprising a chair and a sofa, said support portion being selected from the group comprising a backrest and a seat.
19. An attachment mechanism for connecting a frame and a support portion of an article of furniture, said attachment mechanism comprising a first attachment element configured to be fixed to one of said frame and support portion, and a second attachment element configured to be fixed to the other of said frame and support portion at a position corresponding to that of the first attachment element, said second attachment element being designed to restrain said first attachment element at a desired position relative thereto so as to resist disengagement of the first attachment element therefrom.
20. An attachment mechanism according to Claim 19, wherein:

- 11 -

- said first attachment element comprises a longitudinally extending fastening member comprising a first fastening arrangement; and
- said second attachment element comprises a receiving aperture designed to receive therein said fastening member, and a second fastening arrangement;

5 said first and second fastening arrangements being mutually configured for the restraining.

**21.** An attachment mechanism according to Claim 20, wherein said second fastening arrangement is at least partially disposed within said receiving aperture.

**22.** An attachment mechanism according to any one of Claims 20 and 21, wherein said first fastening arrangement comprises a plurality of longitudinally spaced first engagement elements, and said second fastening arrangement comprises at least one second engagement element, said  
10 first and second engagement elements being mutually configured for the restraining.

**23.** An attachment mechanism according to Claim 22, each of said first engagement elements being formed as a saw-tooth, with a leading surface thereof being formed at a first angle with respect to the fastening member, and a trailing surface being formed at a second angle  
15 substantially perpendicular thereto; said second engagement element being formed as a saw-tooth, with a leading surface thereof, configured to face the leading surface of the first engagement element, being formed at an angle corresponding to said first angle.

**24.** An attachment mechanism according to Claim 23, wherein said first angle does not exceed 40°.

20 **25.** An attachment mechanism according to Claim 24, wherein said first angle is about 30°.

**26.** An attachment mechanism according to any one of Claims 20 through 25, said second attachment element comprising a disengagement mechanism configured to release said first and second fastening arrangements from one another to facilitate disengagement of the first attachment element therefrom.

25 **27.** An attachment mechanism according to Claim 26, said disengagement mechanism comprising a spring element adapted to bias said second fastening arrangement toward said first fastening arrangement when said fastening member is received within said receiving aperture so as to facilitate the restraining, and to allow said second fastening arrangement to be selectively displaced away from said first fastening arrangement to facilitate the disengagement.

30 **28.** An attachment mechanism according to Claim 27, wherein said disengagement mechanism is formed as a cantilevered member, said second fastening arrangement being formed thereupon.

- 12 -

**29.** An attachment mechanism according to Claim 28, said cantilevered member constituting said spring element.

**30.** An attachment mechanism according to any one of Claims 28 and 29, said disengagement mechanism further comprising a spring disposed below said cantilevered member.

**31.** An attachment mechanism according to any one of Claims 19 through 30, wherein said first and second attachment elements are made of a plastic material.

**32.** An attachment mechanism according to any one of Claims 19 through 31, wherein at least one of said first and second attachment elements are formed integrally with the frame and/or support portion.

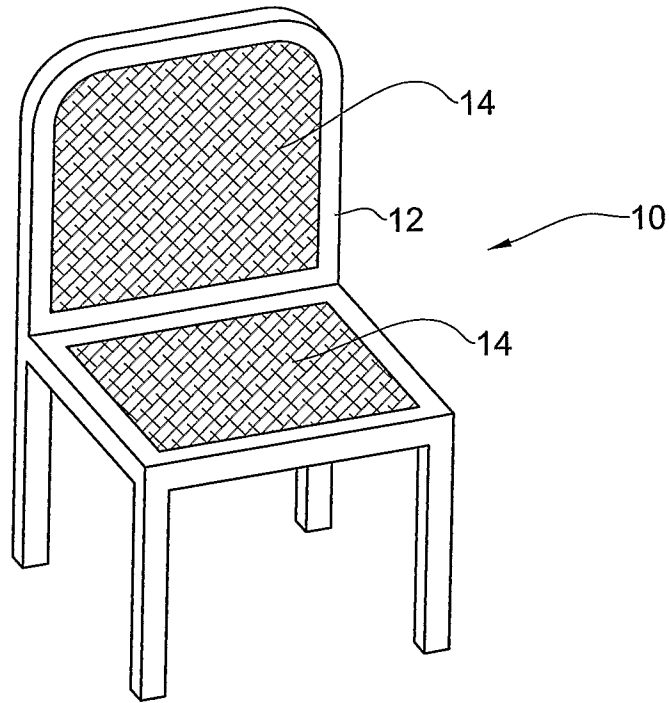

FIG. 1A

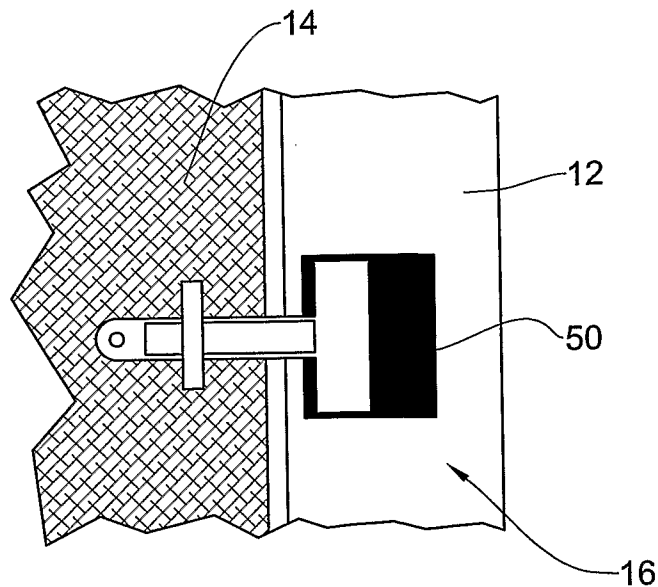

FIG. 1B

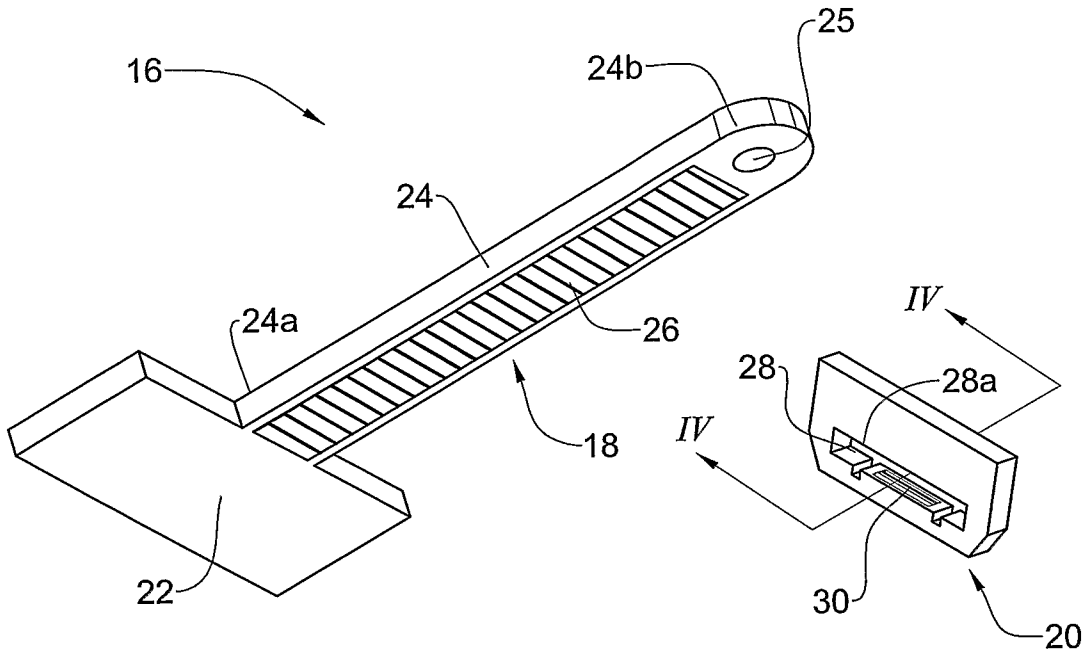

FIG. 2A

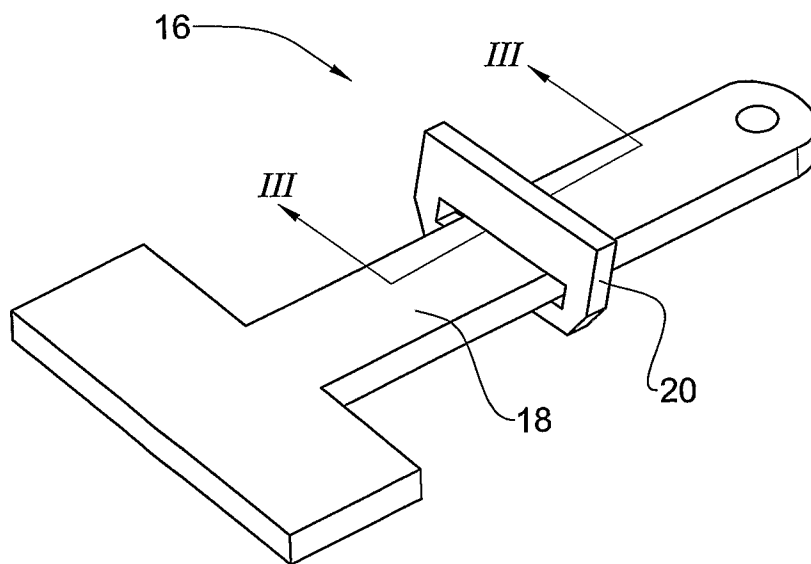

FIG. 2B

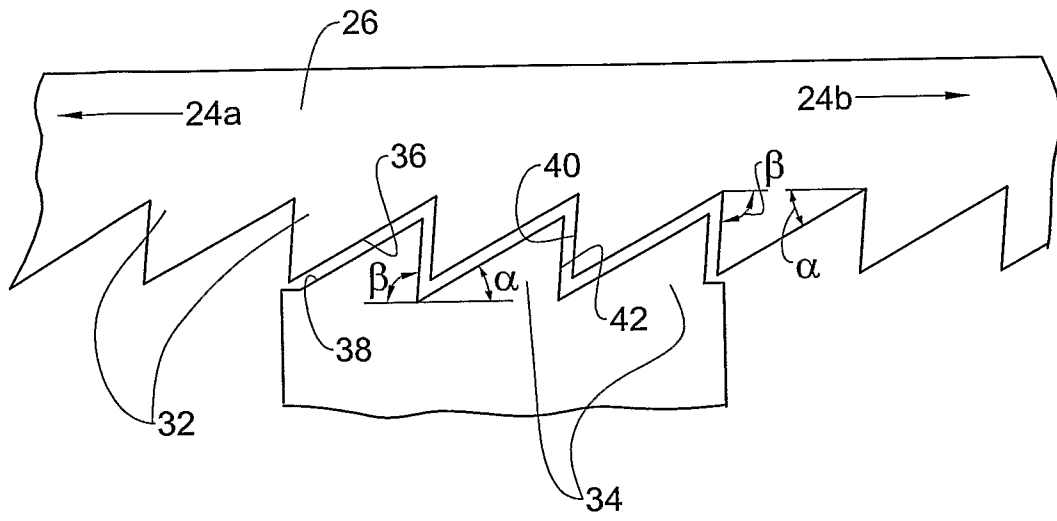

FIG. 3

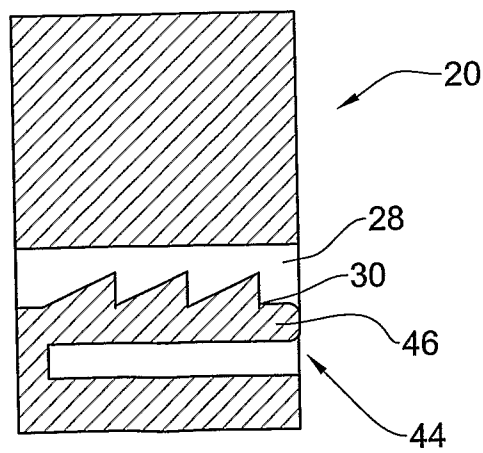

FIG. 4A

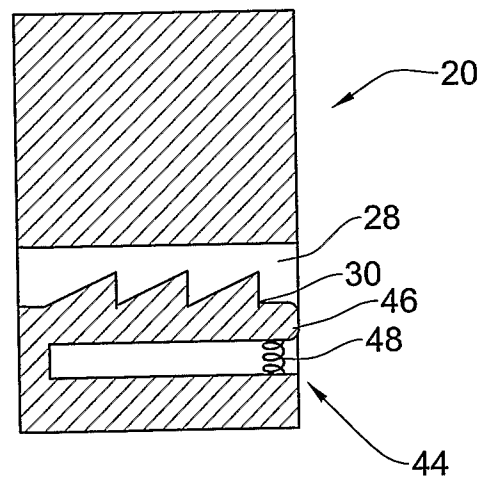

FIG. 4B

## INTERNATIONAL SEARCH REPORT

International application No

PCT/IL2009/000297

## A. CLASSIFICATION OF SUBJECT MATTER

INV. A47C31/02 A47C7/28 A47C7/22 A47C5/06

According to International Patent Classification (IPC) or to both national classification and IPC

## B. FIELDS SEARCHED

Minimum documentation searched (classification system followed by classification symbols)

A47C B60N F16L H02G

Documentation searched other than minimum documentation to the extent that such documents are included in the fields searched

Electronic data base consulted during the international search (name of data base and, where practical, search terms used)

EPO-Internal, WPI Data

## C. DOCUMENTS CONSIDERED TO BE RELEVANT

Category*	Citation of document, with indication, where appropriate, of the relevant passages	Relevant to claim No.
X	DE 101 12 400 A1 (FRAUNHOFER GES FORSCHUNG) 2 October 2002 (2002-10-02) paragraphs [0006], [0009], [0011]; claims; figures	1-32
X	DE 202 12 183 U1 (WERKZEUG TECHNIK SCHMITZ GMBH) 14 November 2002 (2002-11-14) pages 7,8; figures	19-32
A		1-18
X	US 1 645 120 A (STERBENZ) 11 October 1927 (1927-10-11)  figures	1-7, 13, 14, 16, 17, 19-25, 31, 32
	-/--	

 Further documents are listed in the continuation of Box C. See patent family annex.

\* Special categories of cited documents:

- \*A\* document defining the general state of the art which is not considered to be of particular relevance
- \*E\* earlier document but published on or after the international filing date
- \*L\* document which may throw doubts on priority claim(s) or which is cited to establish the publication date of another citation or other special reason (as specified)
- \*O\* document referring to an oral disclosure, use, exhibition or other means
- \*P\* document published prior to the international filing date but later than the priority date claimed

- \*T\* later document published after the international filing date or priority date and not in conflict with the application but cited to understand the principle or theory underlying the invention
- \*X\* document of particular relevance; the claimed invention cannot be considered novel or cannot be considered to involve an inventive step when the document is taken alone
- \*Y\* document of particular relevance; the claimed invention cannot be considered to involve an inventive step when the document is combined with one or more other such documents, such combination being obvious to a person skilled in the art.
- \*Z\* document member of the same patent family

Date of the actual completion of the international search

13 August 2009

Date of mailing of the international search report

24/08/2009

Name and mailing address of the ISA/

European Patent Office, P.B. 5818 Patentlaan 2  
NL - 2280 HV Rijswijk  
Tel. (+31-70) 340-2040,  
Fax: (+31-70) 340-3016

Authorized officer

Kis, Pál

# INTERNATIONAL SEARCH REPORT

International application No

PCT/IL2009/000297

C(Continuation). DOCUMENTS CONSIDERED TO BE RELEVANT

Category*	Citation of document, with indication, where appropriate, of the relevant passages	Relevant to claim No.
A	US 5 459 907 A (NIVET) 24 October 1995 (1995-10-24) abstract; figures -----	

# INTERNATIONAL SEARCH REPORT

Information on patent family members

International application No

PCT/IL2009/000297

Patent document cited in search report	Publication date	Patent family member(s)	Publication date
DE 10112400	A1	02-10-2002	NONE
DE 20212183	U1	14-11-2002	NONE
US 1645120	A	11-10-1927	NONE
US 5459907	A	24-10-1995	DE 4337531 A1 05-05-1994 ES 2072219 A2 01-07-1995 FR 2697592 A1 06-05-1994 IT 1261009 B 29-04-1996