

Nov. 3, 1936.

H. C. WILLIAMS

2,059,994

COMBINED CABINET AND TABLE

Filed Oct. 29, 1935

3 Sheets-Sheet 1

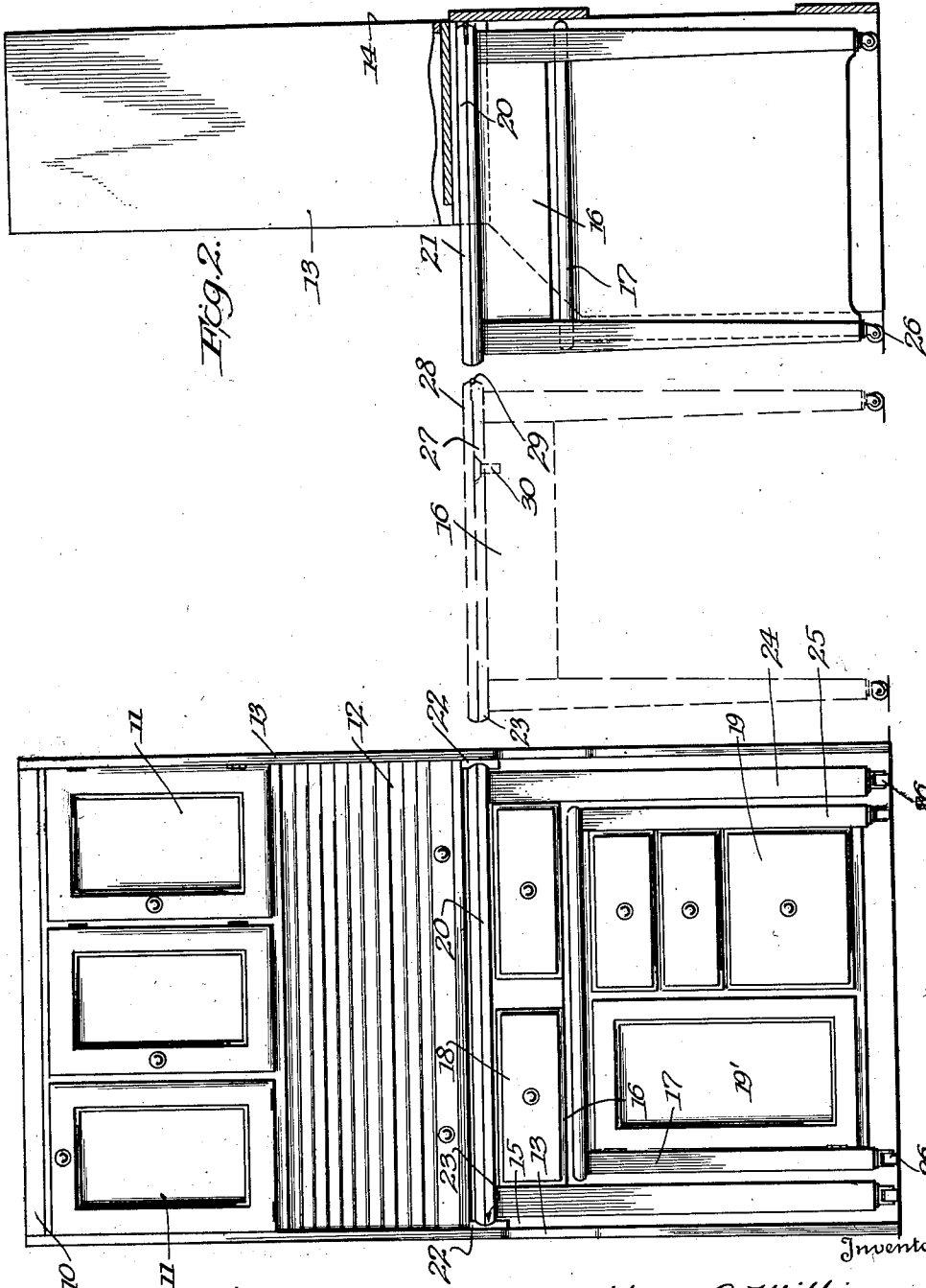

Fig. 2.

Fig. 1.

Inventor

Harry C. Williams.

By *Leahen M. Darby, Lemuel*
Attorneys

Nov. 3, 1936.

H. C. WILLIAMS

2,059,994

COMBINED CABINET AND TABLE

Filed Oct. 29, 1935

3 Sheets-Sheet 2

Fig. 3.

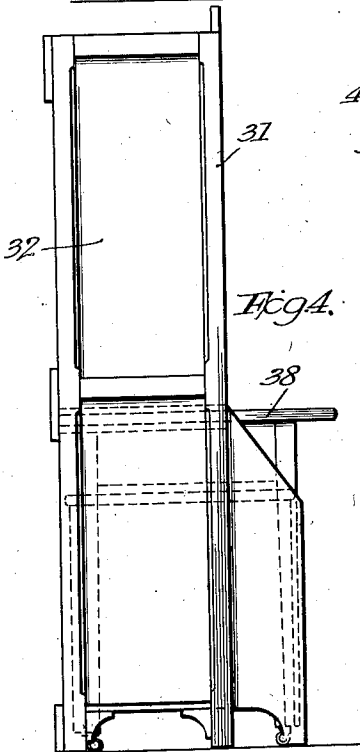
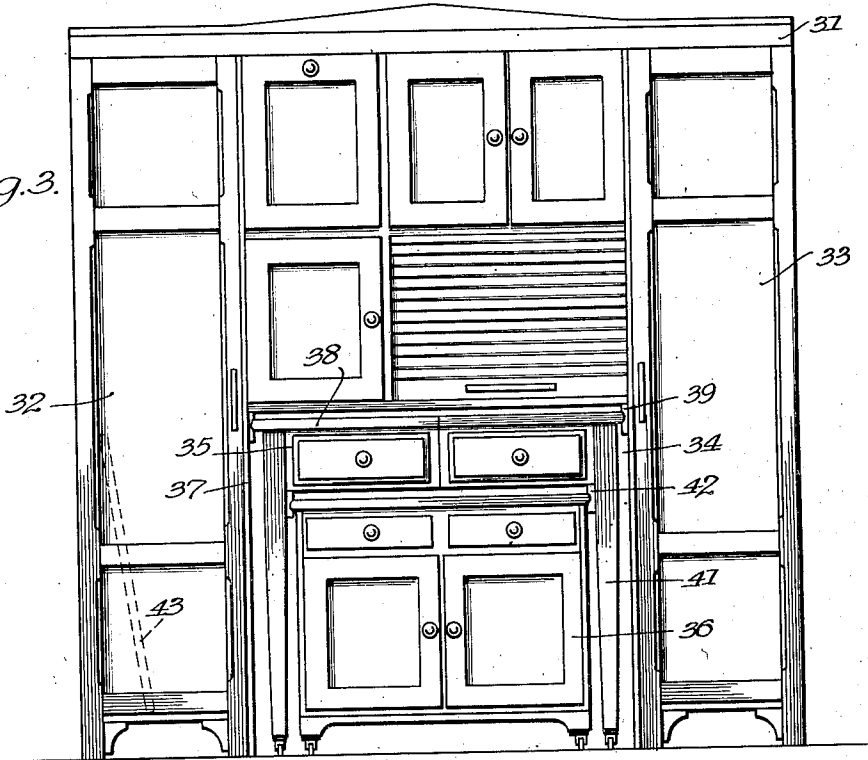

Fig. 4.

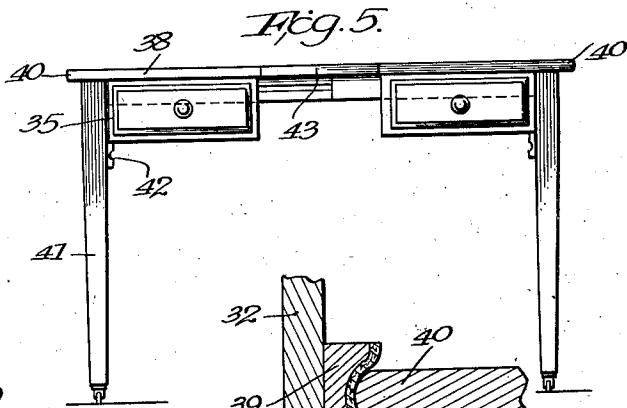

Fig. 5.

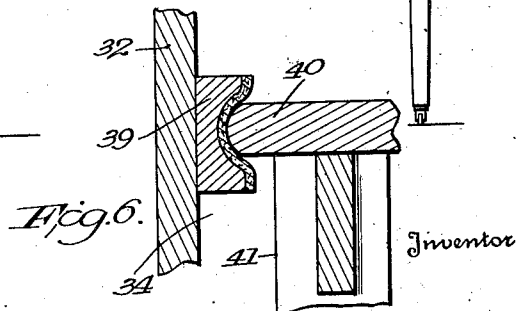

Fig. 6.

Inventor

Harry C. Williams.

By *Ernest A. Darby* & *Ernest A. Darby*
Attorneys

Nov. 3, 1936.

H. C. WILLIAMS

2,059,994

COMBINED CABINET AND TABLE

Filed Oct. 29, 1935

3 Sheets-Sheet 3

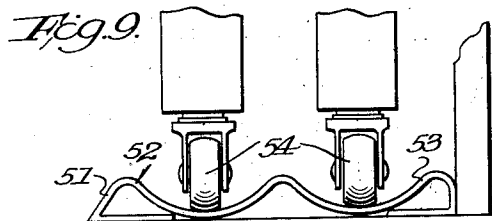
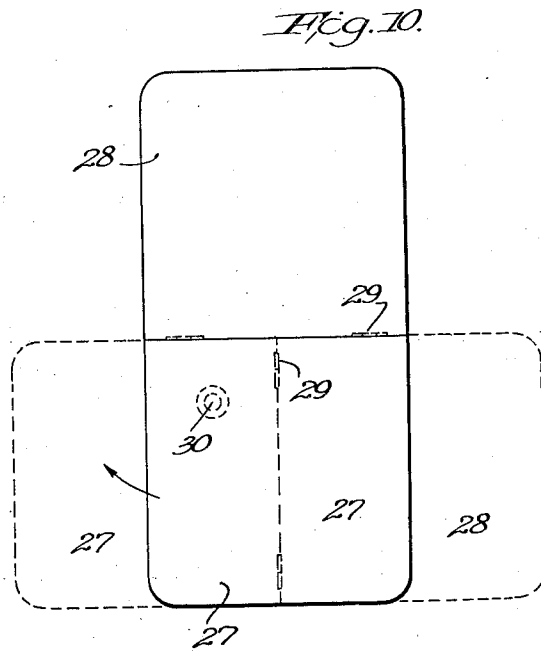
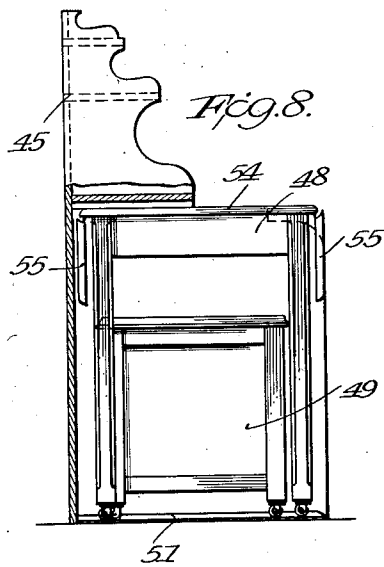
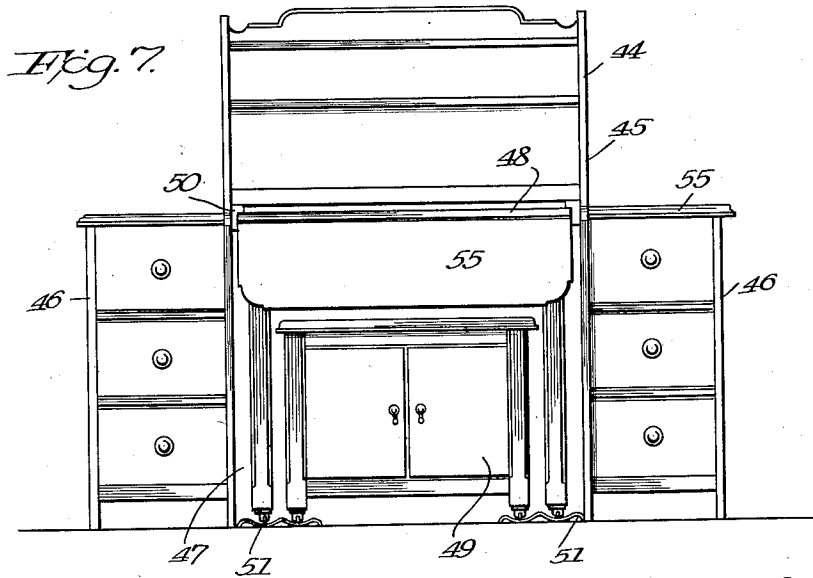

Inventor

Harry C. Williams.

By *Leahman, Derby, & Cushman*
Attorneys

UNITED STATES PATENT OFFICE

2,059,994

COMBINED CABINET AND TABLE

Harry Charles Williams, Louisville, Ky.

Application October 29, 1935, Serial No. 47,298

6 Claims. (Cl. 312-162)

The present invention relates to an improved article of furniture and more particularly to a combined cabinet and removable table structure of such compact shape as to be readily used in rooms of restricted or limited area such as kitchens, kitchenettes, dinettes, and the like.

Heretofore, in articles of furniture of this type, it has been customary to provide the cabinet with a fixed working base and to associate therewith a slidable top connected to the cabinet so as to be movable a limited distance outwardly relative thereto and which functions separately and independently of the fixed base. In order to simplify and improve cabinets of this type, I have provided a removable table which may be conveniently nested within a housing formed in the cabinet so that, when in this position, its top constitutes the working surface or base of the cabinet and which may be entirely withdrawn from the cabinet to provide a separate article of furniture having an open top available for use as a breakfast room table, dinette table or the like.

A further object consists in providing a serviceable, compact and attractive three-piece cabinet combination in which a table and an auxiliary cabinet are arranged and proportioned to be normally nested within a housing formed in the cabinet, and in such a manner that the table and auxiliary cabinet will not impair the efficiency of the cabinet or detract from its otherwise attractive appearance when the table and auxiliary cabinet are positioned within the housing or when they are withdrawn therefrom.

A further object comprehends the provision of a movable base structure which has the dual function of constituting a working surface or bench for the cabinet and which, when entirely removed from the cabinet, forms the top of a table or the like.

A further object consists in associating with a cabinet or similar article of furniture, a removable table and an auxiliary cabinet in which the top of the table normally constitutes an exposed working surface for the cabinet and when entirely removed from the cabinet, provides a separate piece of furniture. The auxiliary cabinet is so associated with the main cabinet and the table to constitute a supplementary working surface for the cabinet when the table is removed and may be withdrawn from the cabinet either with or independently of the table.

A still further object consists in associating with the cabinet means for guiding and maintaining the table and the auxiliary cabinet in

their proper positions when being inserted or removed from the cabinet.

Other objects and advantages of the invention will become apparent from the following description when taken in conjunction with the appended claims.

Referring to the drawings, in which are shown several preferred embodiments of the invention, Figure 1 is a front view of a cabinet having my invention associated therewith;

Figure 2 is a side view of Figure 1 with parts in section for clearness of illustration and showing in dotted line the table withdrawn from the cabinet;

Figure 3 is a front view of a modified form of the invention;

Figure 4 is a side view of Figure 3;

Figure 5 is a front view of the table shown in Figure 3 removed and in its extended position;

Figure 6 is a detailed sectional view of the guide means for the table shown in Figure 3;

Figure 7 is a front view of a further modification;

Figure 8 is a side view with the parts in section of Figure 7;

Figure 9 is a fragmentary view of the guide means shown in Figure 7; and

Figure 10 is a diagrammatic plan view of the top of the table shown in Figure 1 unfolded, and with the top in its extended, operative position shown in dotted lines.

Referring to the drawings in which like numerals indicate like parts in the several views, 10 designates a conventional unitary kitchen cabinet having its upper part provided with separate storing compartments, access to which may be had through the swinging doors 11 and the vertically slidable closure 12. The sides 13 and back 14 of the cabinet extend downwardly to constitute supporting means for the structure, while the lower portion of the sides 13 coact with the intermediate upper portion or bottom of the cabinet to form a housing 15 in which is nested the table 16 and the auxiliary cabinet 17 in the manner as clearly shown in Figure 1. The table 16 may be provided with spaced horizontally disposed drawers 18, while the auxiliary cabinet 17 may be provided with the vertically arranged drawers 19 and a separate compartment closed by the swinging door 19'. The table 16 is of such dimensions as to fit within the housing 15 and when so positioned, its top 20 has a portion 21 extending outwardly beyond the cabinet to constitute an exposed working base or surface. The auxiliary cabinet 17 is of such a

size as to fit within the table 16 so that the parts, when in their nested position, take up very little space in the room.

The opposed inner walls of the sides 13 may be provided with suitable guide means such as the grooved members or slideways 22 located to receive the adjacent edges or flanges 23 of the top so as to insure the table being properly guided and positioned within the cabinet. The grooves of the members 22 are preferably lined with felt in order that the table can be moved into and out of the housing without danger of scratching or marring the same. Instead of a felt lining, any other suitable cushioning means such as roller bearings or the like may be mounted in the groove for guiding and supporting the table in its movement relative to the cabinet.

The table 16 may have either an extensible or non-extensible top and preferably has its upper surface made of porcelain material to provide a smooth working base and one which can be easily kept clean. As shown, the top 20 is of the so-called "twist" type and has its two sections 27 and 28 hinged together as at 29 so that when the sections are in their folded position they overlap one another and are of such dimensions as to fit within the housing 15. When nested in the housing, the exposed porcelain surface of the section 28 constitutes the working base of the cabinet. When the table 16 is withdrawn from the cabinet, its top is of double thickness as shown in dotted lines in Figure 2. The section 28 is then extended to the position shown in Figure 10 and the top is then twisted or swung about its offset pivot or pin 30 to the left as indicated by the arrow, so as to assume its longitudinally extended position as shown in dotted lines in Figure 10. The section 27 of the top is movably connected to the table by the pin 30 so as to be freely movable to its operative and inoperative positions. Normally the top 20 is of such width as to fit within the housing 15 and when removed therefrom may be extended to twice its length.

The auxiliary cabinet 17 may be either withdrawn from the cabinet 10 with the table or remain nested within the housing when the table is removed, so that its top may be utilized as a supplementary working surface for the cabinet. It will therefore be seen that the porcelain top 20 of the table performs the dual function of constituting a working surface or base for the cabinet when the table is nested within the housing and, when the table is withdrawn from the housing, its upper surface is available for use as an ordinary table top.

The cabinet 10 and its associated parts are of such dimensions as to be easily positioned in a kitchen or room in which space is necessarily restrictive. Moreover, the table 16 and the auxiliary cabinet 17 are designed so that when they are nested within the housing, they take up very little space and do not impair the efficiency of the cabinet or detract from its otherwise pleasing appearance. When removed from the cabinet, table 16 and the auxiliary cabinet 17 may be conveniently used as separate articles of furniture in other parts of the room or house. While the cabinet is compact and acts to partially conceal the table 16 and auxiliary cabinet 17 when these parts are nested therein, it also is very spacious and contains a sufficient number of compartments, cupboards and drawers for conveniently storing the necessary kitchen

utensils, towels, and articles of food usually carried by a cabinet of this type.

In the modified form of the invention shown in Figure 3, the cabinet 31 is additionally provided with side compartments 32 and 33 for storing such articles as ironing boards, brooms and the like. The cabinet is also formed with a housing 34 in which may be nested a table 35 and an auxiliary cabinet 36. The opposed inner walls 37 of the housing adjacent the top 38 of the table 35 are preferably provided with felt grooved members 39 (Figure 6) which receive the adjacent sides 40 of the top 38 so as to guide and maintain the table in proper position when the latter is being moved into or out of the housing. Similarly, the legs 41 of the table 35 may be provided with felt grooved members 42 in which the top of the auxiliary cabinet 36 works when the latter is being moved into or withdrawn from the table 35.

As shown, table 35 is extensible and may be lengthened by the addition of leaves 43 which, when not in use, may be placed in the cabinet 32 as shown in dotted lines in Figure 3. It will be observed that the width of the table 35 is such that when it is nested within the housing 34, a portion of the top 38 extends outwardly beyond the cabinet to constitute a working surface or bench, and when the table is withdrawn, the normal length of the top may be extended by the addition of leaves 43 as shown in Figure 5. When it is desired to return the table 35 to its housing in the cabinet, it will of course be necessary to withdraw the leaves 43 so that the top 38 is of the proper length to snugly fit within the housing.

It will be seen that by reason of the various compartments and drawers provided in the cabinet 31, table 35 and auxiliary table 36, that means are provided for conveniently storing the various utensils and equipment required in a kitchen. The table 35 and auxiliary cabinet 36 are of such design and configuration as to harmoniously blend with the cabinet and form therewith, an attractive article of furniture.

In Figures 7, 8 and 9, the invention is shown associated with a china closet-buffet 44. The buffet preferably comprises a china cabinet 45 positioned medially and above spaced sides 46 of the buffet and forms therewith a housing or recess 47 in which may be nested a foldable table 48 and an auxiliary cabinet 49. The opposed walls of the housing 47 are preferably provided with suitable guide means 50 for facilitating the insertion and removal of the table from the housing without danger of scratching or marring the same. A pair of spaced metal track members 51 rests on the floor of the room and are positioned within the housing to constitute guideways 52 and 53 for receiving the casters 54 on the legs of the table 48 and the auxiliary cabinet 49 so as to guide these parts into and out of the housing. The track members 51, if desired, may be secured to the floor by any suitable means such as screws or the like. As shown, the outer ends of the track members 51 abut the adjacent legs of the sides 46 so as to provide a brace for these parts which insures the provision of a rigid structure in which the cabinet is firmly maintained in proper spaced relation with the table.

When the table 48 is nested in the housing, its porcelain top 54 provides a working base for the cabinet and its dropped ends 55 assume the position as shown in Figure 8. On the other hand, when the table is removed from the cabinet, the

ends 55 may be extended to permit its use as a dining room table or the like.

While an auxiliary cabinet has been shown associated with the movable table, it is manifest that this cabinet may be dispensed with, or another article of furniture substituted therefor in the combination. It will be seen that the removable table is admirably suitable for use with different pieces of furniture. Moreover, when the table top and the auxiliary cabinet are not in use, they may be conveniently placed within the cabinet so as to be partially concealed and in such a manner as to take up very little space and not to interfere with the operation of the parts of the cabinet or detract from the appearance thereof.

It is to be understood that the forms of the invention shown are merely illustrative of the preferred embodiments and that such changes may be made as fall within the purview of one skilled in the art without departing from the spirit of the invention or the scope of the appended claims.

I claim:—

1. An article of furniture of the class described including in combination, a cabinet having spaced depending sides, said sides coacting with the cabinet to provide a housing, and a movable table nested within the housing and having a portion of its top projecting outwardly from the cabinet to constitute an exposed working surface, said table being entirely removable from the housing to constitute a separate piece of furniture whereby its top may be utilized as a working surface when nested in said cabinet and an open table top when removed from said cabinet.

2. An article of furniture of the class described including in combination, a cabinet having spaced depending sides, said sides coacting with the cabinet to provide a housing, and a movable table nested within the housing and having a portion of its top extending outwardly from the cabinet to constitute an exposed working surface, said table being entirely removable from the housing to constitute a separate piece of furniture whereby its top may be utilized as a working surface when nested in said cabinet and an open table top when removed from said cabinet, and means for guiding and maintaining the table in position within the housing.

3. An article of furniture of the class described including in combination, a cabinet having spaced depending sides, said sides coacting with the cabinet to provide a housing, and a movable table nested within the housing and having a portion of its top projecting outwardly from the cabinet to constitute an exposed working surface, said table being entirely removable from the housing to constitute a separate piece of furniture whereby its top may be utilized as a working surface

when nested in said cabinet and an open table top when removed from said cabinet, the opposed walls of the housing having grooved means for receiving and guiding the table into and out of the cabinet.

4. An article of furniture of the class described including in combination, a cabinet having spaced depending sides, said sides coacting with the cabinet to provide a housing, a movable table nested within the housing and having a portion of its top extending outwardly from the cabinet to constitute an exposed working surface, said table being entirely removable from the housing to constitute a separate piece of furniture, the top of said table constituting a working surface when nested in said cabinet and an open table top when removed from said cabinet, and spaced track members extending into the housing arranged to slidably receive the lower ends of the legs of the table to guide and maintain the table in proper position when the same is being inserted or withdrawn from the cabinet, the outer sides of said track members abutting the adjacent sides of the cabinet to provide bracing means therefor.

5. An article of furniture of the class described including in combination, a cabinet having spaced depending sides, said sides coacting with the cabinet to provide a housing, a movable table nested within the housing and having a portion of its top extending outwardly from the cabinet to constitute an exposed working surface, said table being entirely removable from the housing to provide a separate piece of furniture, the top of said table constituting a working surface when nested in said cabinet and an open table top when removed from the cabinet, and means in the housing for constituting the working surface of the cabinet when the table is removed from the housing.

6. An article of furniture of the class described including in combination, a cabinet having spaced depending sides, said sides coacting with the cabinet to provide a housing, a movable table nested within the housing and having a portion of its top extending outwardly from the cabinet to constitute an exposed working surface, said table being entirely removable from the housing to provide a separate piece of furniture, the top of said table constituting a working surface when nested in said cabinet and an open table top when removed from the cabinet, movable means in the housing for constituting the working surface of the cabinet when the table is removed from the housing, the legs of said table having casters, and spaced track members extending into the housing and arranged to receive said casters to maintain the table in proper position when the same is being inserted or withdrawn from the cabinet.

HARRY CHARLES WILLIAMS.