



US 20020079764A1

(19) **United States**

(12) **Patent Application Publication**
Cook

(10) **Pub. No.: US 2002/0079764 A1**

(43) **Pub. Date: Jun. 27, 2002**

(54) **COMPRESSOR AND DRIVING MOTOR ASSEMBLY**

(30) **Foreign Application Priority Data**

Dec. 21, 2000 (GB)..... 0031188.6

(75) **Inventor: Roger Cook, Warrington (GB)**

Publication Classification

Correspondence Address:

MICHAEL BEST & FRIEDRICH LLP
3773 CORPORATE PARKWAY
SUITE 360
CENTER VALLEY, PA 18034-8217 (US)

(51) **Int. Cl.⁷ H02K 5/00**

(52) **U.S. Cl. 310/89**

(73) **Assignee: Ingersoll-Rand Company, Woodcliff Lake, NJ**

(57) **ABSTRACT**

(21) **Appl. No.: 09/995,052**

In a compressor and driving motor assembly, the driving motor is a hybrid permanent magnet motor and/or has a rotor mounted directly on the drive shaft of the compressor, the drive shaft acting as a cantilever supporting the rotor.

(22) **Filed: Nov. 27, 2001**

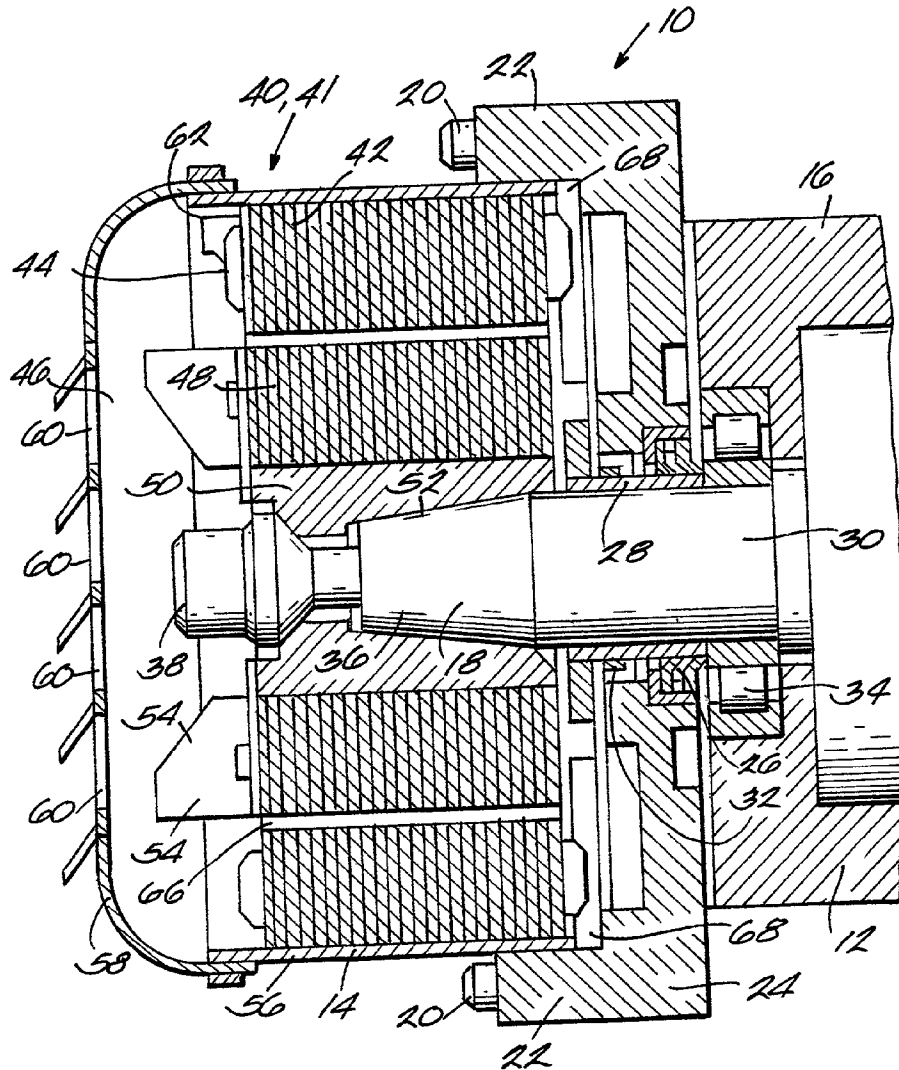

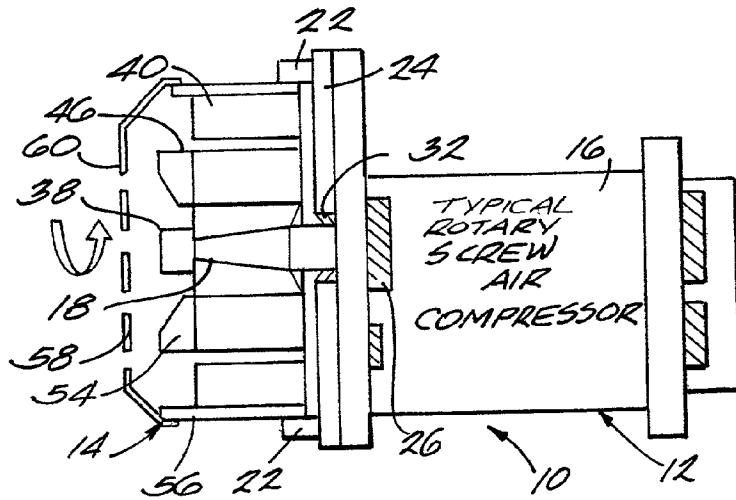
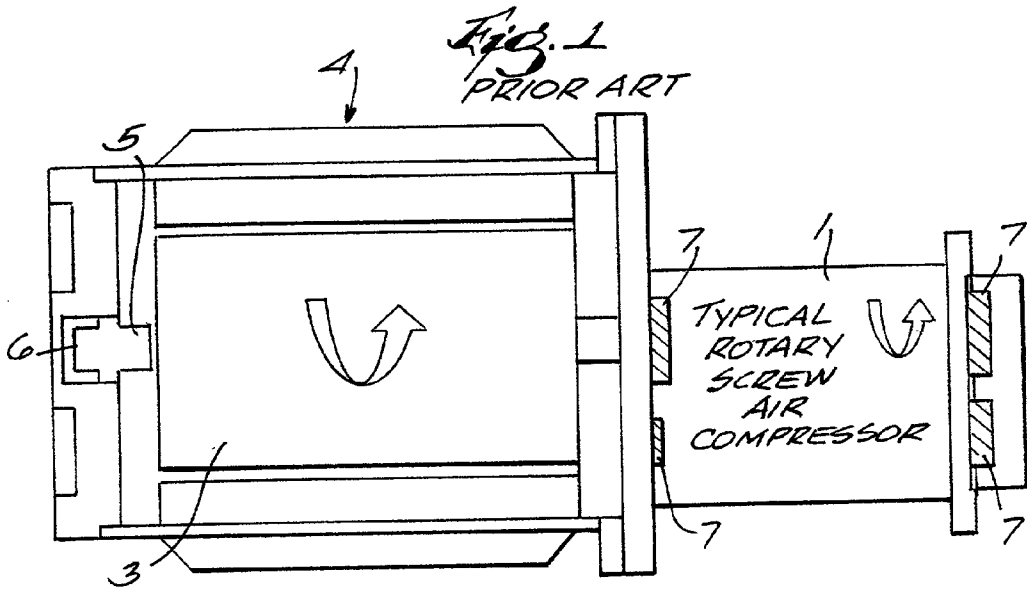

Fig. 2.

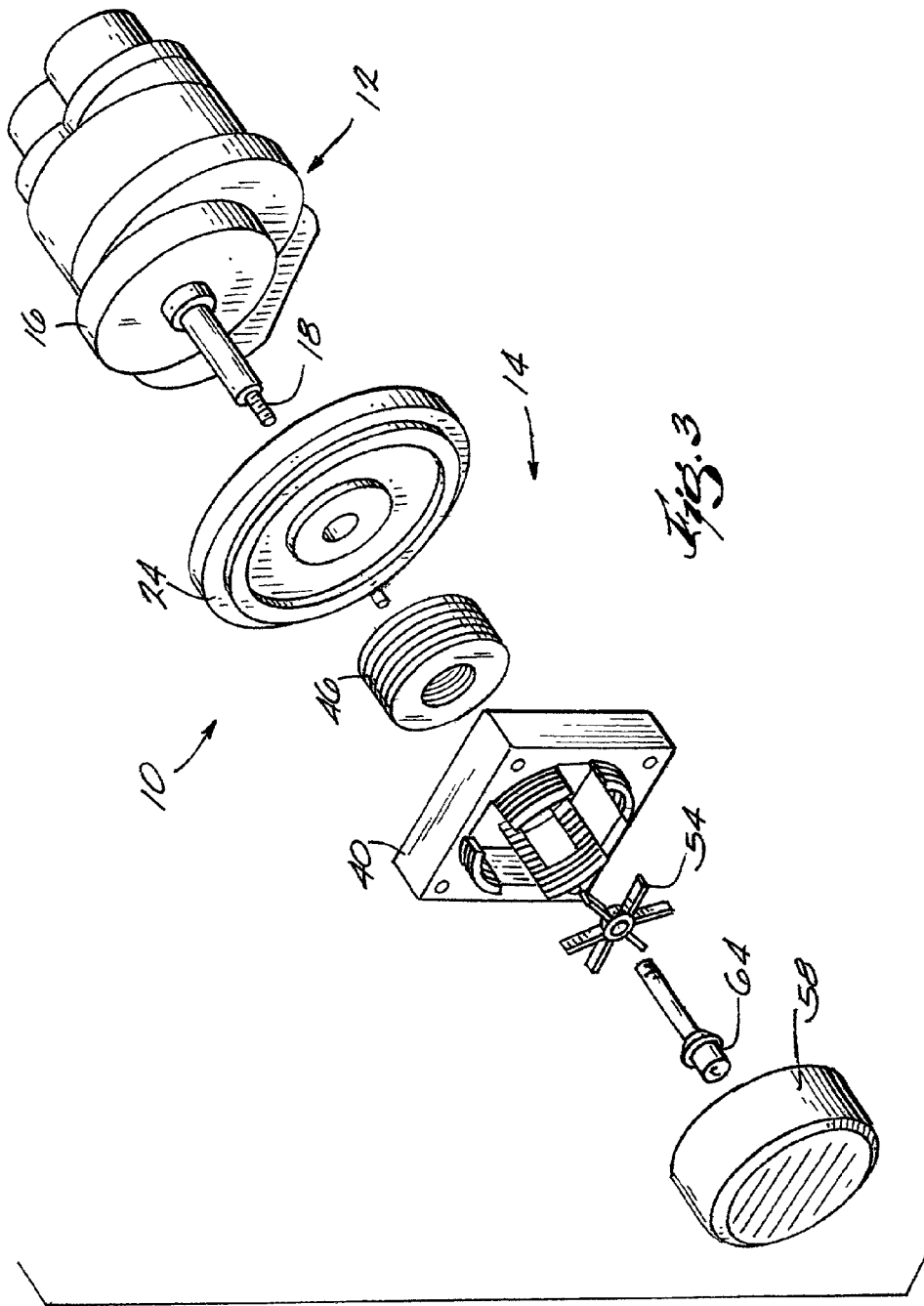

Fig. 3

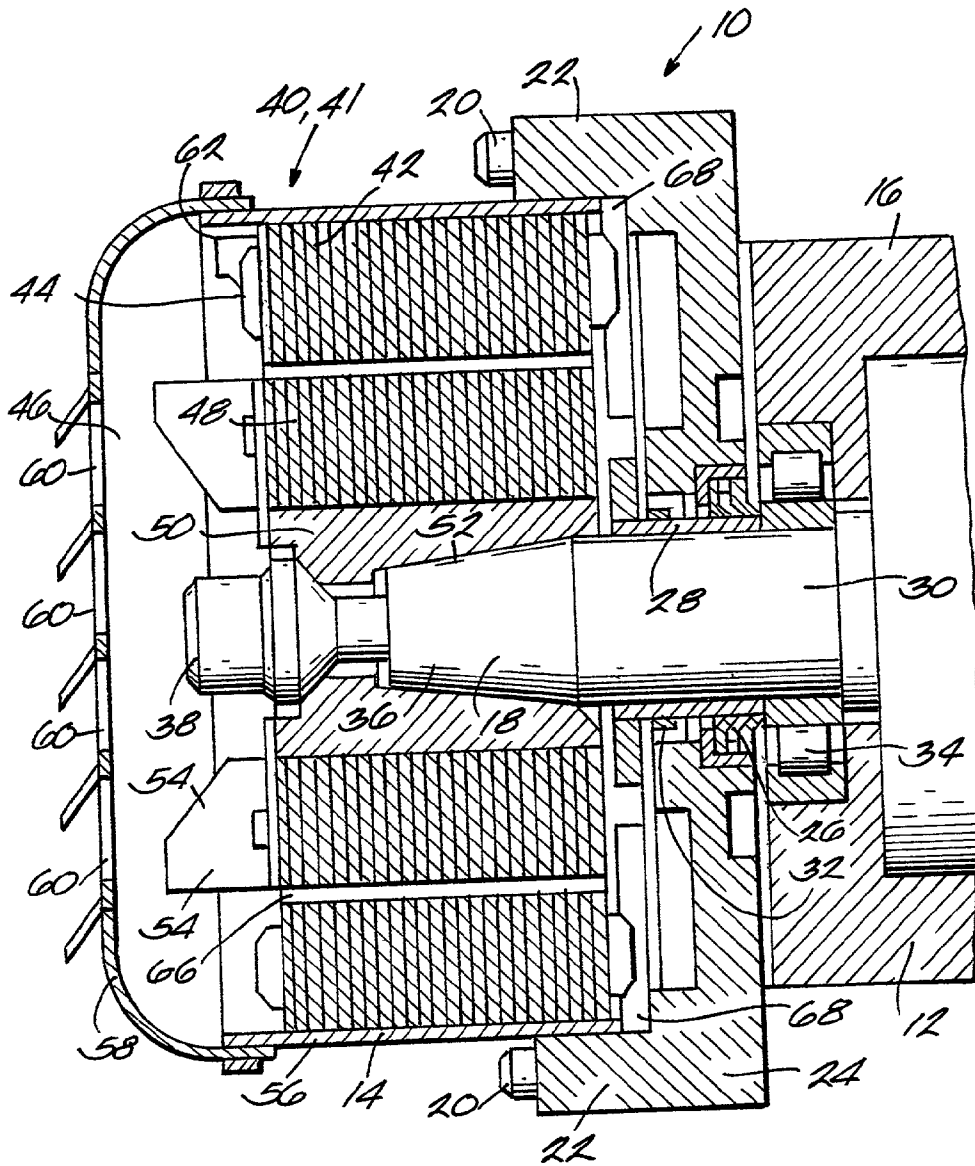

Fig. 4

COMPRESSOR AND DRIVING MOTOR ASSEMBLY

FIELD OF THE INVENTION

[0001] The present invention relates to a compressor and driving motor assembly.

BACKGROUND OF THE INVENTION

[0002] Traditional methods of driving compressors using conventional electric motors include not only direct drive connections, but also intermediate couplings, belts, pulleys and gears. In the simplest known form there is direct drive with the motor rotor joined directly onto the input shaft of a compressor. Such a known compressor and motor assembly is shown in **FIG. 1**. It includes a rotary screw air compressor **1** having bearings **7**, and an extended male input shaft **2** which is connected to the rotor **3** of the motor **4**. Even in this simplest form the shear weight of the rotor requires the rotor **3** and input shaft **2** to be supported on additional bearings **5**.

[0003] Various types of motors are known to be used to drive compressors. For example, fixed speed drive motors known to be used to drive rotary screw air compressors, whether flooded or oil free, have involved induction motors linked to various mechanisms of air flow rate control, such as automatic start and stop and more sophisticated inlet controls which limit flow rate in response to variation in system pressure.

[0004] Variable speed drive motors are also known for use with compressors such as rotary screw air compressors. These include mechanical speed variation motors, variable speed induction motors (VFD), and variable speed switched reluctance motors (SRD).

[0005] Although motors with mechanical speed variation have been tried in limited air compressor applications, these suffer disadvantages of underlying complexity, questionable reliability and overall poor efficiency.

[0006] Variable speed induction motors driven by variable frequency inverters are used more widely. The disadvantages are that there are losses in efficiency due to the electronics involved and limitations imposed by the induction motor itself. Although enhanced in most cases with improved insulation, the induction motor can still be nevertheless a compromise from the reliability and efficiency standpoint.

[0007] In addition, variable frequency induction motors even if modified to withstand the rigours of variable frequency inverter drive are large and intrinsically heavy units. All the compressor products on the market today using VFD drive systems are a development of existing compressor packaging technologies due to the physical constraints imposed by the use of the induction motors. In all these cases the motors which drive the compressors are usually without gears but with adapter housings, couplings, etc. due to the sizes and masses of the motors involved. Additionally, due to the method of construction and the size of the motor windings, rotor assembly, etc., conventional motor construction involving heavy castings, bearings, end shields, couplings, adapter housings and other relatively expensive components are required.

[0008] Compressors are also known involving switch reluctance main drive motors and suitably modified variable frequency inverter drives (SRD), however these also have similar disadvantages.

[0009] As a separate matter, hybrid permanent magnet motors are, in themselves, known. In these, magnetic flux to drive the rotor is produced by both permanent magnets and current flow in electromagnetic coils. Examples are described in, for example, U.S. Pat. Nos 4,079,278 and 4,830,412, United Kingdom patent application GB-A-2291274 and European patent EP-A-0780954.

SUMMARY OF THE INVENTION

[0010] The present invention in its first aspect provides a compressor and driving motor assembly, in which the motor comprises a rotor and a stator assembly, and the compressor comprises a main body which supports a drive shaft, the rotor being mounted directly on the drive shaft, in which the drive shaft acts as a cantilever supporting the rotor.

[0011] In its preferred embodiments, there is thus provided a 'pancake' style motor in the assembly. Support bearing(s) at a distance from the compressor are not required and so are preferably not provided. The direct connection of rotor to drive shaft avoids the need for additional connection means such as couplings, bearings, gears and belts, which would give rise to energy losses, increased complexity and cost, and risks of these components being unreliable. The compressor includes bearings, the loads on which are acceptable in fully supporting the rotor. Preferred embodiments are small and compact and simple in construction and ease of assembly, and are low maintenance.

[0012] The rotor is preferably shaped so as to have a tapered central longitudinal aperture adapted to fit to a correspondingly tapered portion of the drive shaft. The drive shaft preferably includes releasable retaining means operative to secure the rotor once fitted on the drive shaft.

[0013] The stator assembly is preferably connected to the housing of the compressor. This connection is preferably directly to the housing or by way of an adapter flange.

[0014] The compressor is preferably an air compressor. The compressor is preferably a rotary screw compressor.

[0015] The present invention in its second aspect provides a compressor and driving motor assembly, the driving motor being a hybrid permanent magnet motor.

[0016] The present invention in its preferred embodiments advantageously provides a compressor assembly having a smaller and lighter motor than earlier known assemblies involving, for example, induction or SRD-type drive motors. Advantageously the motor is sufficiently small and light that no support bearing at a distance from the compressor is required to support the motor.

[0017] The motor is preferably mounted directly to the compressor. The rotor of the motor is preferably mounted directly on the shaft of the compressor (so as to provide direct drive). The housing of the motor is directly connected to the compressor housing or to a support plate connected to the compressor housing.

[0018] The compressor is preferably an air compressor. The compressor is preferably a rotary screw compressor.

[0019] The motor can be a fixed speed motor or can be a variable speed motor.

[0020] The rotary screw air compressor can be of flooded type or can be of the oil-free type.

[0021] The preferred assembly is small, compact, technically simple, efficient and reliable.

BRIEF DESCRIPTION OF THE DRAWINGS

[0022] Preferred embodiments of the present invention will now be described by way of example and with reference to the drawings in which:

[0023] FIG. 1 is a diagrammatic sectional view of a prior art air compressor and motor assembly,

[0024] FIG. 2 is a diagrammatic section view for comparison with FIG. 1 of a preferred air compressor and motor assembly according to the invention,

[0025] FIG. 3 is an exploded perspective view of the air compressor and motor assembly shown in FIG. 2, and

[0026] FIG. 4 is a more detailed sectional view of a portion of the air compressor and motor assembly shown in FIGS. 2 and 3.

DETAILED DESCRIPTION OF THE PREFERRED EMBODIMENT

The Assembly

[0027] As shown in FIGS. 2 to 4, the preferred compressor and motor assembly 10 consists of a rotary screw air compressor 12 and a motor 14.

The Rotary Screw Air Compressor 12

[0028] The rotary screw air compressor 12 (also known as an airend) includes a housing 16 from which extends a shaft 18 (known as an airend input shaft) in use driven to rotate by the motor 14.

[0029] The motor 14 is located by a spigot (not shown) and attached by bolts 20 entered through mounting blocks 22 to an adapter flange 24 of the compressor 12 connected to the housing 16 of compressor 12. The adapter flange 24 includes a main shaft seal 26 configured to cooperate with a shaft seal wear sleeve 28 around a cylindrical portion 30 of the shaft 18. The adapter flange 24 also includes a shaft dust seal 32 which also cooperates with the sleeve 28. The compressor 12 includes an input shaft bearing 34 within its housing 16.

[0030] The shaft 18 has a frustoconical i.e. tapered end portion 36 having a threaded end aperture (not shown) configured to receive a retention bolt 38.

The Motor

[0031] The motor 14 is a hybrid permanent magnet (HPM) motor 41. It consists of a stator 40 including stator laminations 42 and stator coils 44. The rotor laminations 48 mounted on an apertured rotor shaft 50, the aperture 52 of which is of tapered shape to fit the end portion 36 of the shaft 18 of the compressor 12. The rotor shaft 50 is secured to the shaft 18 of the compressor 12 by retention bolt 38.

[0032] The motor 14 has a motor-cooling fan 54 attached to the rotor 40. The motor 14 has a casing 56 which includes a fan cowling 58. The fan cowling 58 has air inlet apertures 60.

[0033] As shown in FIG. 4, the motor 14 includes at least one rotor positioning sensor 62 or as shown in FIG. 3 optionally includes an encoder 64 (i.e. shaft positioning device).

[0034] There is an air gap 66 between the rotor 46 and stator 40. There are cooling air exits 68 from the motor casing 56 located at a distance from the inlets 60.

[0035] Drive Connection of Motor to Compressor

[0036] As can be seen in FIG. 4, the rotor 46 is mounted directly on to the shaft 18 of the air compressor 12 using a simple tapered fit. This is possible due to the low size and weight of the hybrid permanent magnet motor.

[0037] The rotor 46 is secured using a single retention bolt 38 with the compressor fluid and or the compressed air retained within the compressor itself by a conventional lip sealing arrangement (main seal 26) backed up with a single-lip dust seal 32.

[0038] The stator is then mounted over the rotor located by a spigot feature and retained using mounting blocks 22 and bolts 20. A simple fan cowl 58 to effect the cooling of the motor is provided, however in other embodiments this open drip proof design of cowl in accordance with International Electrical Committee IEC 34-5 Protection Standard No. IP23 is replaced by a totally enclosed cowl in accordance with International Electrical Committee IEC 34-5 Protection Standard IP54 protection.

[0039] Some benefits of the preferred direct i.e. cantilever arrangement of mounting the rotor of the motor to the drive shaft of the compressor can be listed as follows:

- [0040] Reduced assembly time
- [0041] Reduced cost
- [0042] Reduced inventory
- [0043] Reduced dimension
- [0044] Reduced weight
- [0045] Reduced transmission power loss
- [0046] Improved handling
- [0047] No gears
- [0048] No lubrication (motor)
- [0049] No bearings
- [0050] No seals in the motor
- [0051] No alignment procedures
- [0052] No or greatly reduced maintenance
- [0053] Significantly increased reliability
- [0054] Significantly reduced product variants
- [0055] Voltage and frequency variations accommodated by one design

[0056] In some other embodiments of the invention, the compressor is a gas compressor where the gas is other than

air, or a refrigerant compressor. In some other embodiments, the compressor is of reciprocating i.e. piston-type, or rotary type, or any other type having internal rotating elements.

We claim:

1. A compressor and driving motor assembly, in which the motor comprises a rotor and a stator assembly, and the compressor comprises a main body which supports a drive shaft, the rotor being mounted directly on the drive shaft, in which the drive shaft acts as a cantilever supporting the rotor.

2. An assembly according to claim 1 without a bearing acting to support the rotor at a distance from the main body of the compressor.

3. An assembly according to claim 1, in which the motor is a hybrid permanent magnet motor.

4. An assembly according to claim 1, in which the rotor is shaped so as to have a central longitudinal aperture adapted to fit to a corresponding tapered portion of the drive shaft.

5. An assembly according to claim 1, in which the compressor has a housing, and the stator assembly is connected to the housing of the compressor.

6. An assembly according to claim 5, in which the stator assembly is directly connected to the housing.

7. An assembly according to claim 5, in which the stator assembly is connected to the housing by way of an adapter flange.

8. An assembly according to claim 5, in which the compressor is an air compressor.

9. An assembly according to claim 5, in which the compressor is a rotary screw compressor.

10. A rotary screw air compressor and driving motor assembly, the driving motor being a hybrid permanent magnet motor.

11. An assembly according to claim 10, in which the compressor is an air compressor.

12. An assembly according to claim 10, in which the compressor is a rotary screw compressor.

13. An assembly according to claim 10, in which the motor is a fixed speed motor.

14. An assembly according to claim 10, in which the motor is a variable speed motor.

15. An assembly according to claim 10, in which the compressor is of flooded type.

16. An assembly according to claim 10, in which the compressor is of oil-free type.

17. An assembly according to claim 10, in which the motor comprises a rotor which is mounted directly on to a drive shaft of the compressor.

* * * * *