



(51) International Patent Classification:
B23B 49/00 (2006.01)

(21) International Application Number:
PCT/US2024/033314

(22) International Filing Date:
10 June 2024 (10.06.2024)

(25) Filing Language: English

(26) Publication Language: English

(30) Priority Data:
63/507,445 09 June 2023 (09.06.2023) US

(71) Applicant: **TECH PRODUCTS CO.** [US/US]; 300
Greenwood Avenue, Midland Park, New Jersey 07432
(US).

(72) Inventors: **WHITE, Robert**; c/o Tech Products Co., 300
Greenwood Avenue, Midland Park, New Jersey 07432
(US). **WHITE, Ryan R.**; c/o Tech Products Co., 300 Green-
wood Avenue, Midland Park, New Jersey 07432 (US).

(74) Agent: **ZIEGLER, Kristian**; Heslin Rothenberg Farley &
Mesiti P.C., 5 Columbia Circle, Albany, New York 12203
(US).

(81) Designated States (unless otherwise indicated, for every
kind of national protection available): AE, AG, AL, AM,
AO, AT, AU, AZ, BA, BB, BG, BH, BN, BR, BW, BY, BZ,
CA, CH, CL, CN, CO, CR, CU, CV, CZ, DE, DJ, DK, DM,
DO, DZ, EC, EE, EG, ES, FI, GB, GD, GE, GH, GM, GT,
HN, HR, HU, ID, IL, IN, IQ, IR, IS, IT, JM, JO, JP, KE, KG,
KH, KN, KP, KR, KW, KZ, LA, LC, LK, LR, LS, LU, LY,
MA, MD, MG, MK, MN, MU, MW, MX, MY, MZ, NA,
NG, NI, NO, NZ, OM, PA, PE, PG, PH, PL, PT, QA, RO,
RS, RU, RW, SA, SC, SD, SE, SG, SK, SL, ST, SV, SY, TH,
TJ, TM, TN, TR, TT, TZ, UA, UG, US, UZ, VC, VN, WS,
ZA, ZM, ZW.

(84) Designated States (unless otherwise indicated, for every
kind of regional protection available): ARIPO (BW, CV,
GH, GM, KE, LR, LS, MW, MZ, NA, RW, SC, SD, SL, ST,
SZ, TZ, UG, ZM, ZW), Eurasian (AM, AZ, BY, KG, KZ,
RU, TJ, TM), European (AL, AT, BE, BG, CH, CY, CZ,
DE, DK, EE, ES, FI, FR, GB, GR, HR, HU, IE, IS, IT, LT,
LU, LV, MC, ME, MK, MT, NL, NO, PL, PT, RO, RS, SE,

(54) Title: DEPTH SETTING BIT DRIVERS, SYSTEMS AND RELATED METHODS

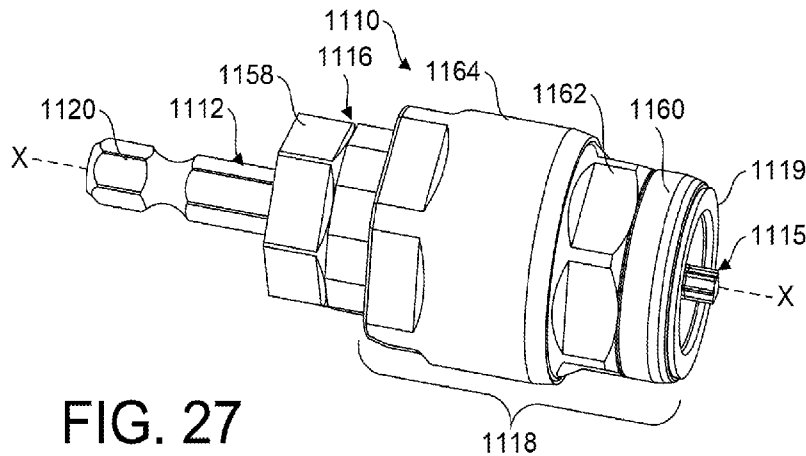

FIG. 27

(57) Abstract: Depth setting bit drivers are provided. The drivers comprise a drive member comprising a drive spindle and a drive body with an adapter cavity and external first bearing surfaces, and a drive connector rotationally coupled and longitudinally fixed within the adapter cavity and a first bearing portion comprising an inner bit retention cavity and a plurality of external second bearing surfaces. The drivers further comprise a drive sleeve comprising a drive cavity comprising a disengagement portion and a clutch portion with internal third bearing surfaces. The first, second and third bearing surfaces are extended along two directions. The drive sleeve is telescopically coupled with the drive member and the drive connector between a longitudinally-extended engaged arrangement with the first and second bearing surfaces engaged with the third bearing surfaces, and a longitudinally-retracted disengaged arrangement with one of the first and second bearing surfaces disengaged from the third bearing surfaces.



SI, SK, SM, TR), OAPI (BF, BJ, CF, CG, CI, CM, GA, GN,
GQ, GW, KM, ML, MR, NE, SN, TD, TG).

Published:

— *with international search report (Art. 21(3))*

(88) Date of publication of the international search report:

17 April 2025 (17.04.2025)

INTERNATIONAL SEARCH REPORT

International application No.

PCT/US 24/33314

A. CLASSIFICATION OF SUBJECT MATTER

IPC - INV. B23B 49/00 (2024.01)

ADD.

CPC - INV. B23B 49/008, B23B 49/00, B23B 49/003, B23B 49/005, B23B 49/006, B23B 2260/12, B25B 23/0064, B25F 5/003

ADD.

According to International Patent Classification (IPC) or to both national classification and IPC

B. FIELDS SEARCHED

Minimum documentation searched (classification system followed by classification symbols)

See Search History document

Documentation searched other than minimum documentation to the extent that such documents are included in the fields searched

See Search History document

Electronic data base consulted during the international search (name of data base and, where practicable, search terms used)

See Search History document

C. DOCUMENTS CONSIDERED TO BE RELEVANT

| Category* | Citation of document, with indication, where appropriate, of the relevant passages | Relevant to claim No. |
|-----------|--|-----------------------|
| A | US 2016/0107299 A1 (CHUNG TAAN INDUSTRIAL CO LTD) 21 April 2016 (21.04.2016) entire document | 1-42 |
| A | EP 0 086 352 A2 (WERNER HERMANN WERA WERKE) 24 August 1983 (24.09.1983) entire document | 1-42 |
| A | DE 3407 180 A1 (GUENTER) 29 August 1985 (29.08.1985) entire document | 1-42 |
| A | EP 0 346 231 A1 (AEROSPATIALE) 13 December 1989 (13.12.1989) entire document | 1-42 |
| A | US 2002/0127070 A1 (MAWHINNEY) 12 September 2002 (12.09.2002) entire document | 1-42 |

 Further documents are listed in the continuation of Box C. See patent family annex.

* Special categories of cited documents:

"A" document defining the general state of the art which is not considered to be of particular relevance

"D" document cited by the applicant in the international application

"E" earlier application or patent but published on or after the international filing date

"L" document which may throw doubts on priority claim(s) or which is cited to establish the publication date of another citation or other special reason (as specified)

"O" document referring to an oral disclosure, use, exhibition or other means

"P" document published prior to the international filing date but later than the priority date claimed

"T" later document published after the international filing date or priority date and not in conflict with the application but cited to understand the principle or theory underlying the invention

"X" document of particular relevance; the claimed invention cannot be considered novel or cannot be considered to involve an inventive step when the document is taken alone

"Y" document of particular relevance; the claimed invention cannot be considered to involve an inventive step when the document is combined with one or more other such documents, such combination being obvious to a person skilled in the art

"&" document member of the same patent family

Date of the actual completion of the international search

01 November 2023

Date of mailing of the international search report

NOV 29 2024

Name and mailing address of the ISA/US

Mail Stop PCT, Attn: ISA/US, Commissioner for Patents
P.O. Box 1450, Alexandria, Virginia 22313-1450

Facsimile No. 571-273-8300

Authorized officer

Kari Rodriguez

Telephone No. PCT Helpdesk: 571-272-4300

INTERNATIONAL SEARCH REPORT

International application No.

PCT/US 24/33314

Box No. II Observations where certain claims were found unsearchable (Continuation of item 2 of first sheet)

This international search report has not been established in respect of certain claims under Article 17(2)(a) for the following reasons:

- 1. Claims Nos.:
because they relate to subject matter not required to be searched by this Authority, namely:

- 2. Claims Nos.:
because they relate to parts of the international application that do not comply with the prescribed requirements to such an extent that no meaningful international search can be carried out, specifically:

- 3. Claims Nos.:
because they are dependent claims and are not drafted in accordance with the second and third sentences of Rule 6.4(a).

Box No. III Observations where unity of invention is lacking (Continuation of item 3 of first sheet)

This International Searching Authority found multiple inventions in this international application, as follows:
SEE EXTRA SHEET

- 1. As all required additional search fees were timely paid by the applicant, this international search report covers all searchable claims.
- 2. As all searchable claims could be searched without effort justifying additional fees, this Authority did not invite payment of additional fees.
- 3. As only some of the required additional search fees were timely paid by the applicant, this international search report covers only those claims for which fees were paid, specifically claims Nos.:

- 4. No required additional search fees were timely paid by the applicant. Consequently, this international search report is restricted to the invention first mentioned in the claims; it is covered by claims Nos.:
1-42

Remark on Protest

- The additional search fees were accompanied by the applicant's protest and, where applicable, the payment of a protest fee.
- The additional search fees were accompanied by the applicant's protest but the applicable protest fee was not paid within the time limit specified in the invitation.
- No protest accompanied the payment of additional search fees.

INTERNATIONAL SEARCH REPORT
Information on patent family members

International application No.

PCT/US 24/33314

.*-Continuation of: Box No. III Observations where unity of invention is lacking (Continuation of item 3 of first sheet)-.*

This application contains the following inventions or groups of inventions which are not so linked as to form a single general inventive concept under PCT Rule 13.1. In order for all inventions to be searched, the appropriate additional search fees must be paid.

Group I: Claims 1-42, directed to

a drive body (22; Figs. 1-16) comprising an inner adapter cavity (24; Figs. 1-16) and a plurality of external circumferentially-arranged first bearing surfaces (25; Para. [00102]; Fig. 3);
a drive connector (14; Fig. 3) comprising a coupling portion (32; Fig. 3) rotationally coupled and longitudinally fixed within the adapter cavity (Para. [00104]; Fig. 4) and a first bearing portion (34; Fig. 4) comprising an inner bit retention cavity (36; Para. [00104]; Fig. 4) and a plurality of external circumferentially-arranged second bearing surfaces (35; Para. [00105]; Fig. 4);
a drive sleeve (16; Fig. 4) comprising a longitudinal drive cavity (21; Fig. 4) comprising a disengagement portion (47; Fig. 6) with non-bearing internal surfaces and a clutch portion (drive portion 46; Fig. 6) comprising a plurality of internal circumferentially-arranged third bearing surfaces (Para. [00107]); and
a stop portion (18; Fig. 3) rotationally coupled to the drive sleeve (Para. [00118]),
wherein the drive sleeve is telescopically coupled with the drive member and the drive connector between a longitudinally extended engaged arrangement (Fig. 5) and a longitudinally retracted disengaged arrangement (Fig. 6) with respect thereto (Para. [00100], [00107]-[00108]),
wherein bearing surfaces rotationally lock the drive member and the drive connector (Paras. [00106] and [00108]-[00109]); and
wherein the disengagement portion rotationally unlocks the drive member and the drive connector (Paras. [00106] and [00108]-[00109]).

Group II: Claims 43-72 directed to

a drive body (622; Figs. 17-18) comprising a drive cavity (621; Figs. 17-18), wherein the drive cavity comprises a bit retention portion (636; Figs. 17-18) and a clutch portion; (646; Paras. [00126]-[00136]; Figs. 17-18);
a drive clutch (unnumbered body including bearing portion 626 and through hole 670; Figs. 17-18) extending within the clutch portion of the drive cavity (Paras. [00127]-[00136]; Figs. 18);
a stop sleeve (618; Figs. 17-18) comprising a stop portion (660; Figs. 17-18) rotationally coupled and longitudinally fixed to the drive clutch (Paras. [00128], [00130], [00135]; Figs. 17-18);
a resilient member (613; Figs. 17-18) that biases the drive clutch (Para. [0128]);
wherein the drive cavity comprises a disengagement portion (650; Figs. 17-18) and an engagement portion (651; Paras. [00129]-[00134]; Figs. 17-18);
wherein bearing surfaces rotationally lock the drive member and the drive clutch (Paras. [00129]-[00134]; Figs. 17-18),
wherein the drive member, the drive clutch and the stop sleeve are configured to rearrange from the longitudinally extended engaged arrangement to a longitudinally retracted disengaged arrangement (Paras. [00129]-[00134]; Figs. 17-18).

The inventions listed as Groups I-II do not relate to a single general inventive concept under PCT Rule 13.1 because, under PCT Rule 13.2, they lack the same or corresponding special technical features for the following reasons:

SPECIAL TECHNICAL FEATURES

The invention of Group I includes the special technical feature of

a drive body comprising an inner adapter cavity and a plurality of external circumferentially-arranged first bearing surfaces that are extended along two-dimensions;
a drive connector comprising a coupling portion rotationally coupled and longitudinally fixed within the adapter cavity and a first bearing portion comprising an inner bit retention cavity and a plurality of external circumferentially-arranged second bearing surfaces that are extended along two directions;
a drive sleeve comprising a longitudinal drive cavity comprising a disengagement portion with non-bearing internal surfaces and a clutch portion comprising a plurality of internal circumferentially-arranged third bearing surfaces that are extended along two directions;
and
a stop portion rotationally coupled to the drive sleeve comprising a longitudinal free end portion configured to engage a workpiece, wherein the drive sleeve is telescopically coupled with the drive member and the drive connector between a longitudinally extended engaged arrangement and a longitudinally retracted disengaged arrangement with respect thereto,
wherein, in the longitudinally extended engaged arrangement, the first and second bearing surfaces are in engagement with the third bearing surfaces to rotationally lock the drive member and the drive connector; and
wherein, in the longitudinally retracted disengaged arrangement, one of the first and second bearing surfaces are positioned within the disengagement portion of the drive cavity to rotationally unlock the drive member and the drive connector;
not required by the claims of Group II.

The invention of Group II includes the special technical feature of a

a drive member comprising a drive spindle and a drive body comprising a drive cavity, wherein the drive cavity comprises a bit retention portion and a clutch portion;
a drive clutch extending within the clutch portion of the drive cavity;
a stop sleeve comprising a sleeve portion extending about a portion of the drive body and a stop portion rotationally coupled and longitudinally fixed to the drive clutch;
a resilient member that biases the drive clutch,
wherein the drive cavity comprises a disengagement portion with non-bearing internal surfaces and an engagement portion with a plurality of internal-circumferentially-arranged second bearing surfaces, the disengagement portion being positioned longitudinally between the engagement portion and the drive spindle,
wherein, in the longitudinally extended engaged arrangement, the first bearing surfaces extend within the engagement portion of the drive cavity and about second bearing surfaces to rotationally lock the drive member and the drive clutch; and
wherein the drive member, the drive clutch and the stop sleeve are configured to rearrange from the longitudinally extended engaged arrangement to a longitudinally retracted disengaged arrangement with the first bearing surfaces positioned within the disengagement portion of the drive cavity to rotationally unlock the drive member and the drive clutch;
not required by the claims of Group I.

INTERNATIONAL SEARCH REPORT

International application No.

PCT/US 24/33314

.*-Continuation of previous extra sheet: Box No. III Observations where unity of invention is lacking (Continuation of item 3 of first sheet)

.*-

COMMON TECHNICAL FEATURES

Groups I-II share the common technical features of a depth setting bit driver configured to rotate a bit about a longitudinal axis of the driver, comprising:

- a drive member comprising a drive spindle and a drive body comprising an inner adapter cavity;
 - a plurality of first bearing surfaces that are extended along two-dimensions;
 - a disengagement portion with non-bearing internal surfaces and a clutch portion comprising a plurality of circumferentially-arranged third bearing surfaces that are extended along two-dimensions; and
 - a stop portion rotationally coupled,
 - a longitudinally extended engaged arrangement and a longitudinally retracted disengaged arrangement,
- wherein, in the longitudinally extended engaged arrangement, the first bearing surface is in engagement with the third bearing surfaces to rotationally lock; and
- wherein, in the longitudinally retracted disengaged arrangement, the first bearing surface is positioned within the disengagement portion to rotationally unlock.

However, this shared technical feature does not represent a contribution over prior art as being obvious over US 2016/0107299 A1 to CHUNG TAAN INDUSTRIAL CO., LTD. (hereinafter referred to as CHUNG TAAN INDUSTRIAL) in view of EP 0 086 352 A2 to WERNER HERMANN WERA WERKE (hereinafter referred to as WERNER HERMANN WERA WERKE).

CHUNG TAAN INDUSTRIAL discloses a depth setting bit driver (connector 1; Fig. 1) configured to rotate a bit about a longitudinal axis of the driver (Abstract and Para. [0007]), comprising:

- a drive member (connecting rod 6; Fig. 1) comprising a drive spindle (lower end of connecting rod 6 as shown in Fig. 3) and a drive body (abutting section 61 and an annular groove 62; Para. [0022]; Fig. 3);
 - a plurality of first bearing surfaces (abutting section 61; Para. [0022]; Fig. 3);
 - a disengagement portion (radially-enlarged section 222; Fig. 3) with non-bearing internal surfaces and a clutch portion (restraining section 221; Fig. 3) comprising a plurality of circumferentially-arranged third bearing surfaces (Para. [0018]); and
 - a stop portion (abutting member 42; Fig. 3) rotationally coupled (Para. [0019]),
 - a longitudinally extended engaged arrangement (as shown in Fig. 6; Para. [0024]) and a longitudinally retracted disengaged arrangement (as shown in Fig. 4; Para. [0023]),
- wherein, in the longitudinally extended engaged arrangement, the first bearing surface is in engagement with the third bearing surfaces to rotationally lock (Para. [0024]; Fig. 6); and
- wherein, in the longitudinally retracted disengaged arrangement, the first bearing surface is positioned within the disengagement portion to rotationally unlock (Para. [0023]; Fig. 4).

CHUNG TAAN INDUSTRIAL fails to teach of
the drive body comprising an inner adapter cavity.

WERNER HERMANN WERA WERKE discloses a depth setting bit driver (as shown in Fig. 1) configured to rotate a bit about a longitudinal axis of the driver (Abstract) and teaches of

- a drive body (clamping pin 1; Pg. 3, Lines 24-25; Fig. 1) comprising an inner adapter cavity (cavity for inserting the shaft 8prime of sleeve 8 as shown in Fig. 2; Pg. 3, Lines 29-30).

It would have been obvious to one of ordinary skill in the art at the time the invention was made to reconfigure the drive body of CHUNG TAAN INDUSTRIAL to include an inner adapter cavity as taught by WERNER HERMANN WERA WERKE, since rearranging parts of an invention only involves routine skill in the art and this would allow for the use of an adaptor that can be easily changed out without having to replace the entire depth setting bit driver.

As the common technical features were known in the art at the time of the invention, these cannot be considered special technical feature that would otherwise unify the groups.

Therefore, Groups I-II lack unity under PCT Rule 13 because they do not share a same or corresponding special technical feature.