

E. H. HOBLING.
 CONSTRUCTION OF BLINDS OR SCREENS.
 APPLICATION FILED SEPT. 17, 1912.

1,083,096.

Patented Dec. 30, 1913.

2 SHEETS—SHEET 1.

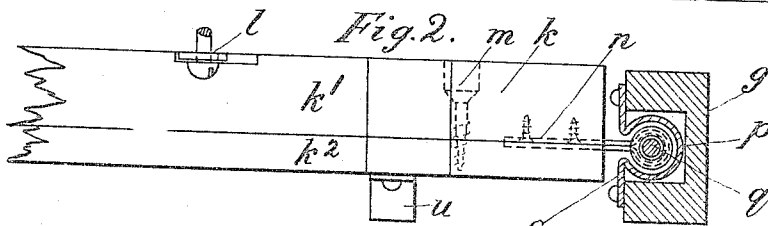
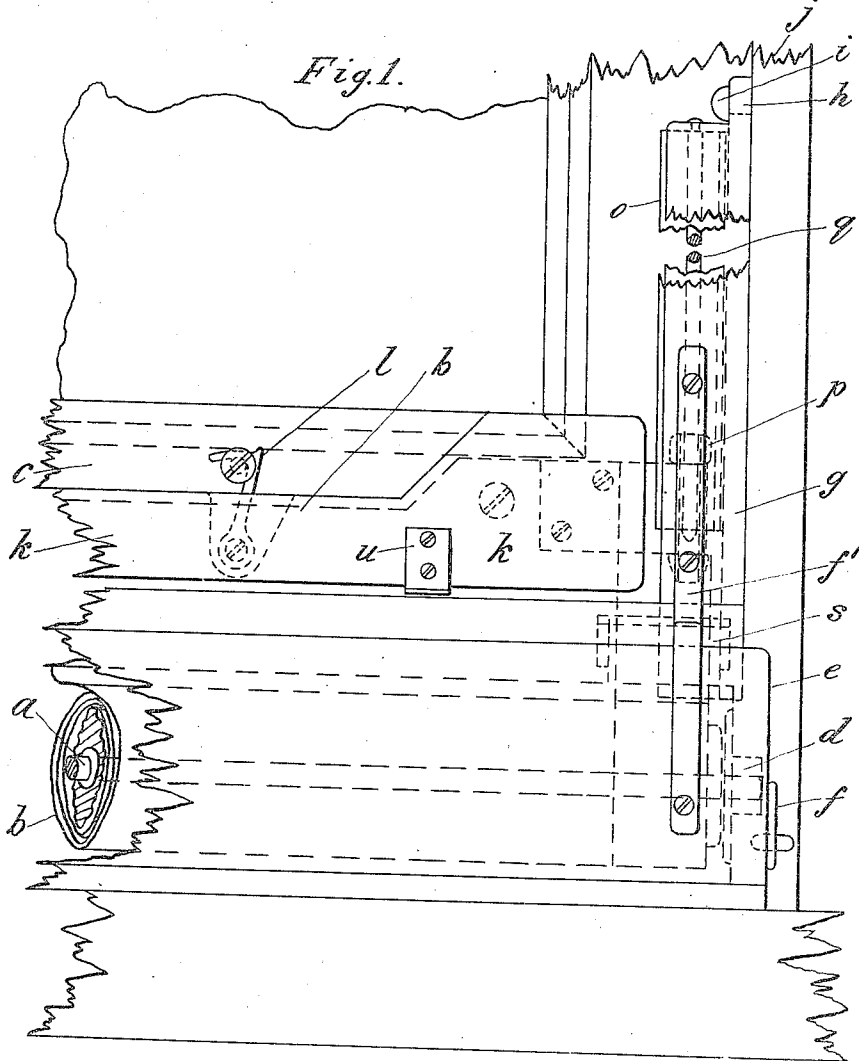

Witnesses.
John Michael
W. E. Moore

Ernest Henry Hobling
 Inventor.
 By *Wm. E. Moore*
 Atty.

E. H. HOBLING.
 CONSTRUCTION OF BLINDS OR SCREENS.
 APPLICATION FILED SEPT. 17, 1912.

1,083,096.

Patented Dec. 30, 1913.

2 SHEETS—SHEET 2.

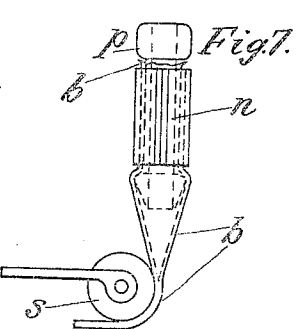
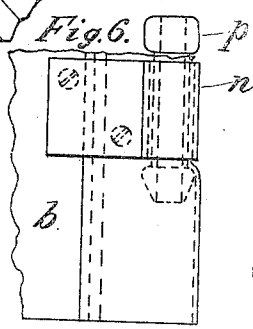
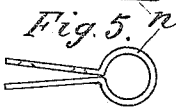
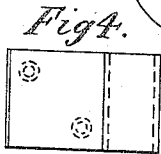
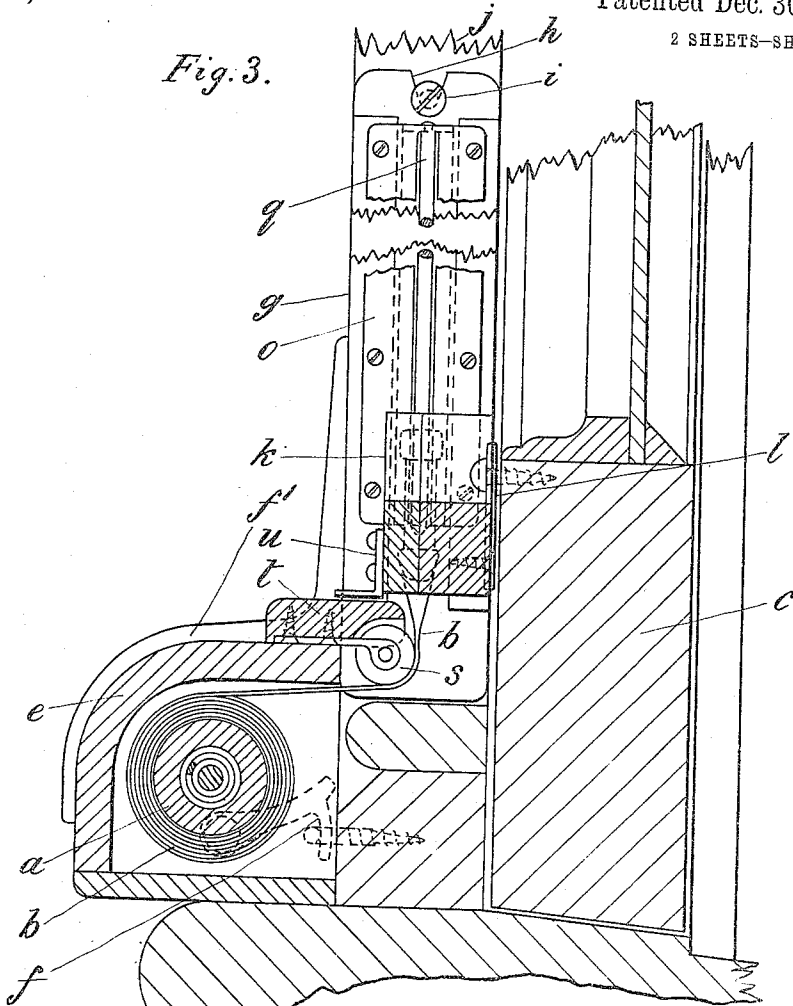

Witnesses.
 J. W. Michael
 H. E. Moore

Ernest Henry Hobling
 Inventor.
 By J. W. Moore
 Atty.

UNITED STATES PATENT OFFICE.

ERNEST HENRY HOBLING, OF LEYTON, ENGLAND.

CONSTRUCTION OF BLINDS OR SCREENS.

1,083,096.

Specification of Letters Patent.

Patented Dec. 30, 1913.

Application filed September 17, 1912. Serial No. 720,725.

To all whom it may concern:

Be it known that I, ERNEST HENRY HOBLING, schoolmaster, a subject of the King of Great Britain and Ireland, and residing at 542 High road, Leyton, in the county of Essex, England, have invented certain new and useful Improvements in the Construction of Blinds or Screens, of which the following is a specification.

10 My invention relates to improvements in the construction of blinds or screens, more particularly to such as have one end of the screening material removably attached to a window sash, or its equivalent, and the other 15 end attached to a spring roller contained in a suitable casing removably attached to the window frame or its equivalent; the sides of the material traveling in suitable guiding channels removably attached to the sides 20 of the window frame or its equivalent.

The object of my invention is to provide means for rendering such blinds or screens more easily applicable to various forms of windows, doors or other openings, and to 25 provide more efficient means for fastening the screen material to the guiding appliances in such manner as to reduce the wear and tear of the material as it travels over or under or through the necessary guides; 30 and to provide an improved form of traveling guide for the sides of the screen material by means of which friction is considerably reduced.

Reference to the accompanying drawings, 35 in which similar parts are denoted by similar letters will enable my invention to be more easily understood.

It is evident that the external diameter of a blind or screen wound upon a spring-roller 40 will vary according to the number of thicknesses of the material wound upon it, and that consequently the angle of lead taken by the material passing on its way from the spring-roller to the vertical guides will also 45 vary, tending to cause undesirable friction and wear of the material by preventing it from having a fair and straight lead into the guides. To obviate this defect I provide an auxiliary roller or series of rollers 50 under or over which the screen material may pass as it is wound upon or unwound from the spring-roller, and I locate the auxiliary roller or rollers in such a position with regard to the guides that the screen material 55 has a fair and straight lead into the side guides at all times.

In the accompanying drawings—Figure 1 is a front view of a portion of a screen embodying my invention. Fig. 2 is a top view of the bar carrying one end of the screen material attached at each side by one 60 of my improved clips or clamps. Fig. 3 is a sectional side view corresponding with Fig. 1. Fig. 4 is a side view and Fig. 5 is a top view of one of my improved clips or 65 clamps. Fig. 6 is a side view of one of the clips surrounding and clamping the edge of the screen material around a guide tube *p*, having enlarged ends, designed to slide upon the guide rod *q* shown in Fig. 2 inclosed in 70 the slotted guide tube *o* and its protecting casing *g*. Fig. 7 is an end view of the clip shown in Fig. 6 showing also the screen material being delivered in an approximately 75 straight direction under the auxiliary roller as also shown in Fig. 3. Figs. 1 and 3 show my invention as applied for example to the lower sash of a window, although I do not limit myself to this application.

a represents a spring-roller blind of well 80 known construction having one end of the screen material fastened to it and several thicknesses of the screen material *b* wound upon it. The window sash *c* is shown closed or in its lowest position. I inclose the said 85 spring-roller provided with suitable bearings *d* in a protecting case *e* of wood or other suitable material and attach the case to the fixed portion of the window frame by catches *f* and by brackets *f*¹ to vertical guide 90 pieces *g* removably attached to the sides of the window frame *j* by any suitable means such as slots *h* engaging with screws or pins *i* fixed to the window frames. The other 95 end of the screen material is attached to the bar *k* (preferably by making the bar in two pieces and clamping the material between them) catches *l* being provided for removably attaching the bar *k* to the movable window sash *c*. 100

The attachment of the screen material *b* to the ends of the bar *k* is more clearly shown in Fig. 2, the bar being shown as made in two pieces *k*¹ and *k*² clamped together by the screw *m*. The clip *n* shown 105 also in Figs. 4 and 5 is attached to the bar *k* by suitable screws and travels up and down inside the metal guides *o*, the sides of the screen material *b* formed by seaming into long pockets being clamped and fixed between the clip *n* and the sliding tubular 110 guide *p*. Similar clips and guides are pro-

vided at both sides of the blind. The tubular guide *p* slides up and down upon the guide rod *q* attached to the upper end of the vertical slotted guide tube *o*.

5 It will be understood by referring to Fig. 3 that the screen material *b*, when drawn from the spring-roller *a* by raising the window sash *c*, will be led in a direct line into the vertical guides *o* by passing under the auxiliary roller or rollers *s* attached preferably as shown at *t* to the protecting cover *e*.

10 To prevent the spring-roller from pulling the screen material so far down as would allow the sliding tubular guides *p* to pass beyond the ends of the guide-rods *q*, I provide the stop piece *u* as shown in Figs. 1, 2 and 3.

Having now fully described the nature of my said invention, what I claim and desire to secure by Letters Patent is:—

20 1. In ventilating blinds or screens, the combination of a spring roller, a screen adapted to be wound upon said roller, vertical guide rods, tubular sliding guides fitting

on said guide rods, clips for securing the screen to said guides, and an auxiliary guiding roller. 25

2. In ventilating blinds or screens, a guide rod, a vertical slotted guide tube, to the upper end of which said guide rod is attached, a tubular guide slidable upon said guide rod, a bar, screening material and a clip securing the same to said bar. 30

3. In ventilating blinds or screens, a guide rod, a vertical slotted guide tube, to the upper end of which said guide rod is attached, a tubular guide slidable upon said guide rod, a bar, screening material and a clip securing the same to said bar, said tubular guide having an enlarged end for cooperation with said clip. 35 40

In witness whereof I have hereunto set my hand in the presence of two witnesses.

ERNEST HENRY HOBLING.

Witnesses:

W. E. PRYCE,
F. M. MELLOR.