

H. SCHMITZ.
CENTRIFUGAL MACHINE.
APPLICATION FILED JULY 29, 1908.

934,221.

Patented Sept. 14, 1909.
4 SHEETS—SHEET 1.

Fig. 1.

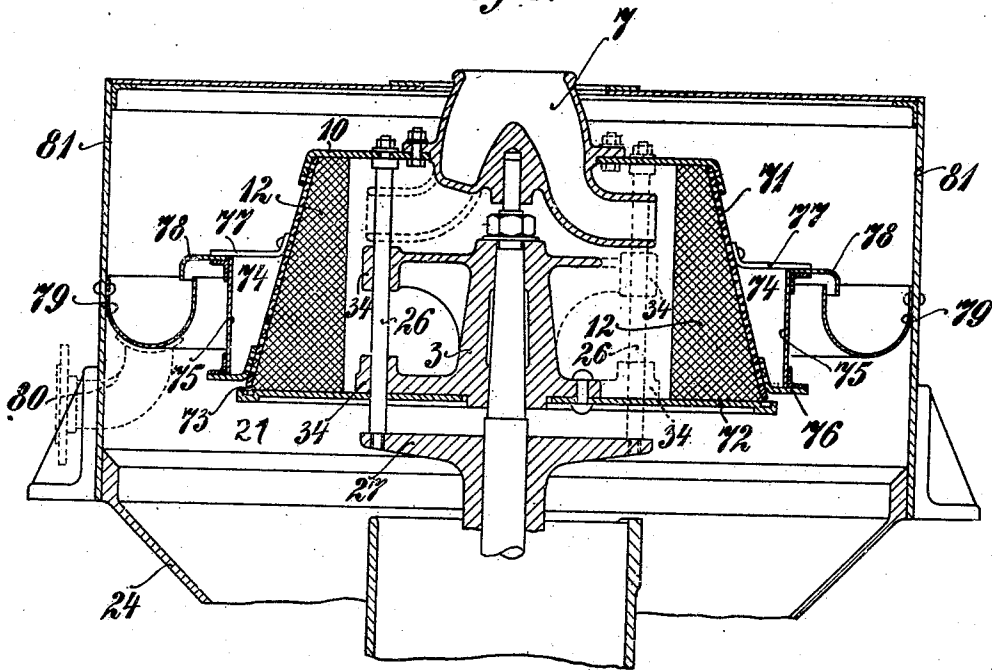
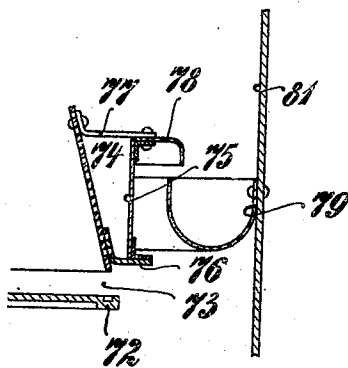

Fig. 2.



Witnesses:
G. Heinicke
E. Spawke

Inventor
Hugo Schmitz
per J. Sittman
Attorney.

H. SCHMITZ.
CENTRIFUGAL MACHINE.
APPLICATION FILED JULY 29, 1908.

934,221.

Patented Sept. 14, 1909.

4 SHEETS—SHEET 2.

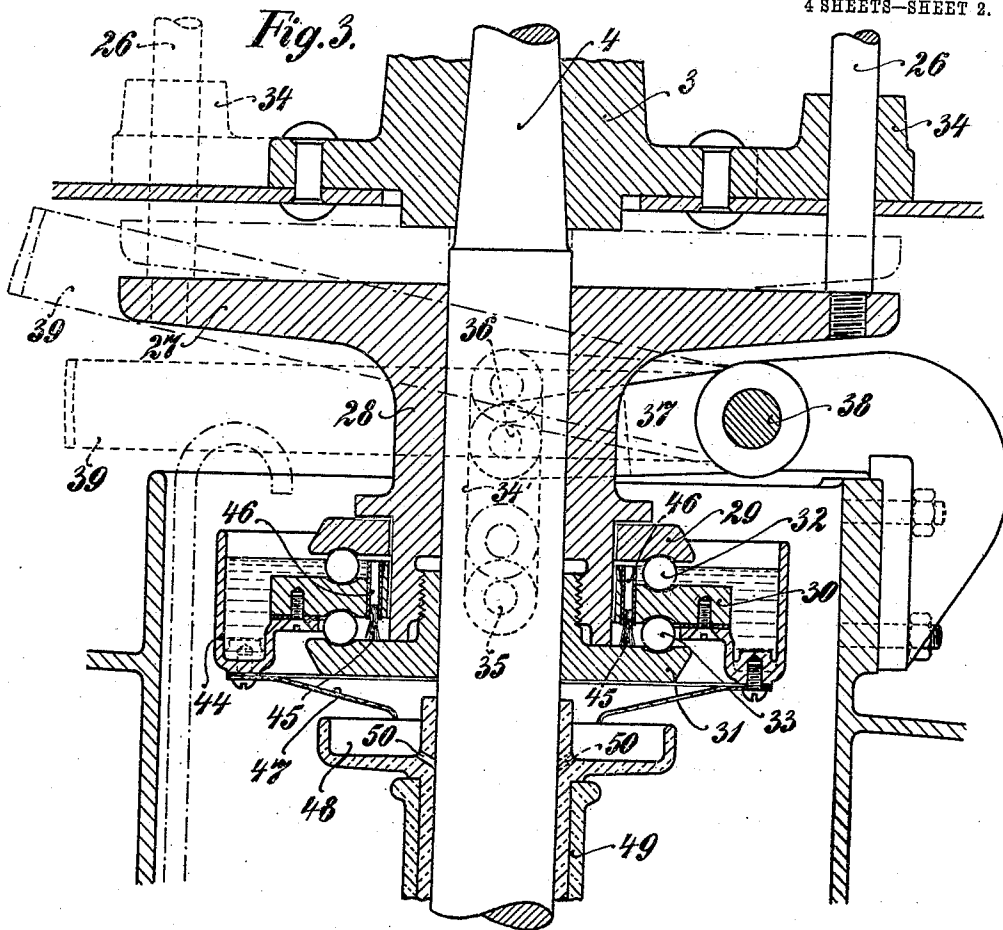
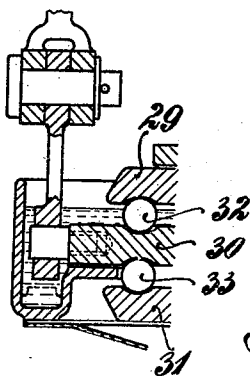

Fig. 4.



Witnesses:

L. Schmitz
F. Franke

Inventor
Hugo Schmitz
per *G. Littman*
Attorney.

H. SCHMITZ.
CENTRIFUGAL MACHINE.
APPLICATION FILED JULY 29, 1908.

934,221.

Patented Sept. 14, 1909.

4 SHEETS—SHEET 3.

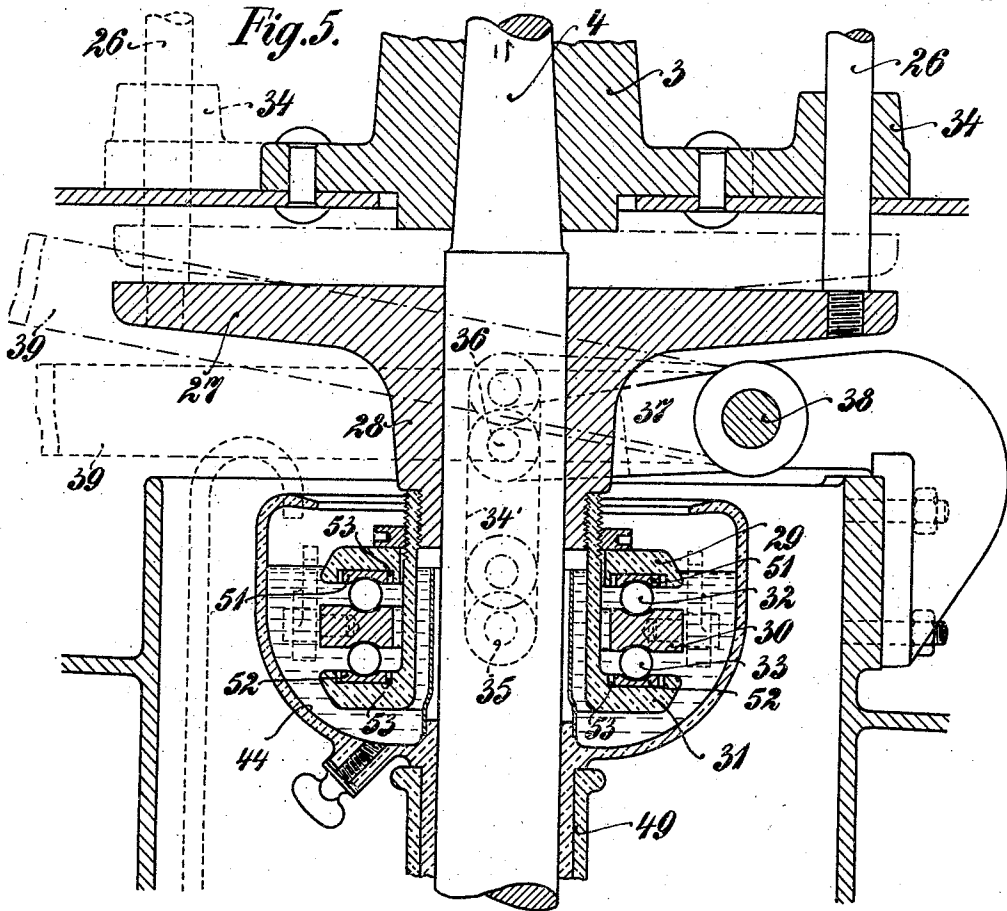
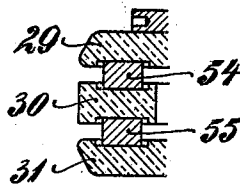

Fig. 6.



Witnesses:
Ger. Heinicke
S. Franke.

Inventor
Hugo Schmitz
per G. Lütman
Attorney.

H. SCHMITZ.
CENTRIFUGAL MACHINE.
APPLICATION FILED JULY 29, 1908.

934,221.

Patented Sept. 14, 1909.
4 SHEETS—SHEET 4.

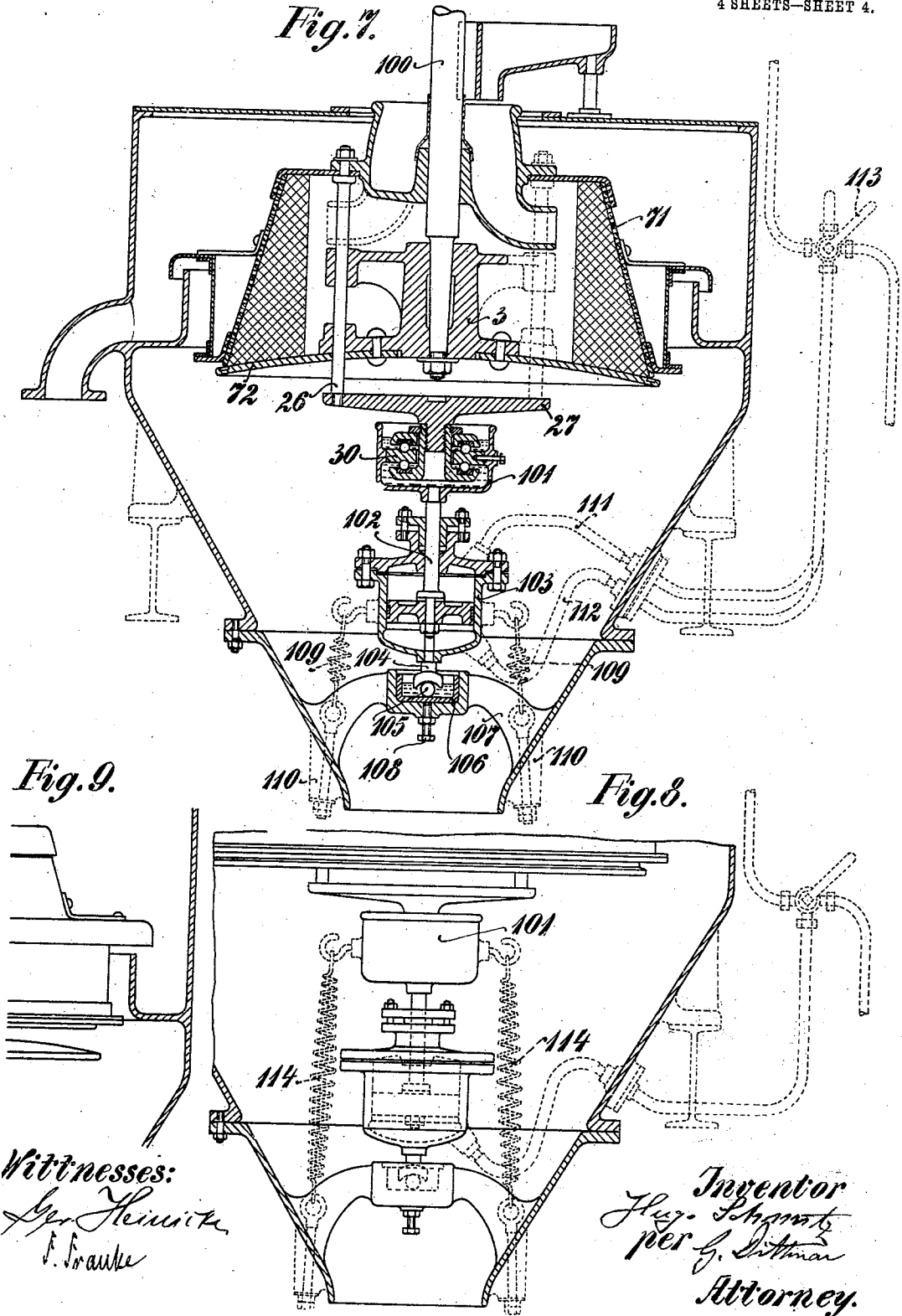

Fig. 9.

Fig. 8.

Witnesses:
G. Schmitz
J. Frank

Inventor
G. Schmitz
per *G. Dittmar*
Attorney.

UNITED STATES PATENT OFFICE.

HUGO SCHMITZ, OF GREVENBROICH, GERMANY.

CENTRIFUGAL MACHINE.

934,221.

Specification of Letters Patent. Patented Sept. 14, 1909.

Application filed July 29, 1908. Serial No. 445,998.

To all whom it may concern:

Be it known that I, HUGO SCHMITZ, a subject of the King of Prussia, German Emperor, residing at Grevenbroich, in the Province of the Rhine, Kingdom of Prussia, German Empire, have invented certain new and useful Improvements in Centrifugal Machines, of which the following is a specification.

10 This invention relates to improvements in centrifugal machines for semi-solid materials, especially for the drying of sugar crystals, and more particularly relates to centrifugal machines of that kind in which during the operation, that is to say, during the revolution of the drum, the material contained can be discharged by lifting the lid, or in a reversed construction by lifting the drum under the influence of the centrifugal force. In the first case the drum is widened out in funnel shape upward in the well known manner, and in the second case it is widened downward.

25 The invention comprises means for separating in such machines the liquid passing out through the perforated sides of the drum from the finished dried material, and for preventing a mixture thereof; it further comprises means for the lifting of the drum lid or of the drum itself in the most suitable manner, and thereby facilitating the discharge of the finished contents.

35 Referring to the drawings, Figure 1 shows a vertical section through the upper part of the centrifugal machine. Fig. 2 shows a detail of this machine. Fig. 3 shows on an enlarged scale the section of the device for raising the drum placed underneath the same. Fig. 4 shows a detail of the mechanism illustrated in Fig. 3. Fig. 5 shows a section similar to Fig. 4 through another construction of the lifting mechanism. Fig. 6 shows another construction of the same. Fig. 7 shows a vertical section through the centrifugal machine provided with another kind of lifting mechanism. Fig. 8 shows a sectional elevation of another constructional form of this lifting mechanism. Fig. 9 shows an elevation and part section of a portion of the drum shown in Fig. 7 in the opened position.

50 In Figs. 1, 7, 8 and 9, it is assumed that the centrifugal drum widens conically down-

ward and that for the purpose of the discharge it is lifted from the fixed bottom, so that the contents are discharged through the opening thus formed under the influence of the centrifugal force and their own gravity. Obviously, however, the improvements can also be applied to centrifugal drums which widen upward conically, from which, for the purpose of discharge, the top is lifted, so that the opening is formed above through which the contents are thrust out by the action of the centrifugal force alone.

65 In Fig. 1, 71 indicates the centrifugal drum with perforated walls which widen downward conically.

70 72 indicates the bottom from which the drum 71 is raised for the purpose of the discharge of the contents indicated by the cross shading. The drum is permanently closed above by means of the lid 10 and the contents to be dried are introduced through the filling apparatus 7. The bottom 72 is fixed to the boss 3 and revolves with it when the drum 71 is set in motion, but cannot move during the discharge of the apparatus in the axial direction like the drum 71.

80 The lifting of the drum is effected by means of the part 27 which is connected by several rods 26 with the lid 10 of the drum 71. The rods 26 in this construction pass through slots 34 in the boss 3. The manner in which the base plate 27 is raised will be explained farther on. When the drum 71 is raised, then there is formed at 73 an annular opening, through which the contents 12 escape into the receptacle 21, and are passed through the hopper 24 down to a discharge channel not shown in the drawing. The liquid which passes out during the operation through the perforations of the drum 71, first passes into the collecting space 74 surrounding the drum, which space is limited at its lower half by the cylindrical shield 75. The partition is fastened below to the annular flange 76 which forms at the same time the bottom of the collecting space, and is firmly secured above by means of the ribs 77 to the perforated cover of the drum 71, and consequently participates in the rotary motion thereof.

105 The partition 75 can be formed, instead of being cylindrical as in the drawing, in the form of a cone widening upward, which

construction is still more practical because the discharge of the accumulated liquid is thereby facilitated.

From the space 74 the liquid flows under the influence of the centrifugal force over the widened edge 78 of the partition 75 into the annular and fixed channel 79 from which it flows through the curved tube 80. This annular channel is preferably secured to the casing 81 surrounding the entire apparatus, and is arranged so that the escaping liquid may have a quick discharge and there may be no accumulation.

For the vertical motion of the lifting plate 27 and with it the drum 71 or in the reversed arrangement for the lifting of the lid closing the drum, the arrangement illustrated in Figs. 3 and 4 on a larger scale has been devised. The part 27 possesses a sleeve shaped guide 28, which surrounds and is adjustable upon the drum shaft 4, and rotates with the drum on the balls 32, 33, which are retained by plates 29, 30 and 31. The middle one 30 of these plates does not participate in the rotary motion and is only displaceable in the longitudinal direction of the shaft upward or downward, and in consequence of the rigid connection of this plate with the oil receptacle 44, the drum can be raised until the guide piece 28 strikes against the boss 3, and be lowered again. At the same time the boss 3 with its guide arms 34 serves for the guiding and support of the rods 26. To the lower ends of the guide pieces 28 there is screwed the already mentioned plate shaped disk 31. Between the latter and the upper disk 29 is placed the fixed disk 30 which is only displaceable in the longitudinal direction of the shaft. This disk 30 is held fast in its position by means of a lever mechanism and is moved thereby. The lever mechanism comprises the pressure or drawbars 34' which connect to correspondingly arranged pivots 35 of the disk 30 placed beside the shaft and diametrically opposed at their lower ends, and with their upper end by means of pivots 36 attached to the cross levers 37, which levers 37 stand at 38 in connection with the lever mechanism 39. This latter is placed outside the casing of the centrifugal machine and is operated by means of a roller and cord connected to a hand wheel (not shown in the drawing). If now, by aid of this lever mechanism, the disk 30 and consequently the guide piece 28 and the lid 10 are raised for the purpose of discharging the contents of the drum, then by turning the hand wheel brackets not shown the bar 39 is drawn upward and this motion is transmitted by means of the intermediate parts 34', 37 to the disk 30, whereby the cover is raised. The lid may be held in its closed position in any suitable manner.

The ball bearings 32, 33 in which the

guide piece 28 revolves by means of the disks 29 and 31 on the fixed disk 30, are arranged to run in oil, and this oil in the oil receptacle 44 which surrounds the disk 30 and is fixed to it, lubricates the upper ball bearing and the oil passes through the small pipes 46 provided with wicks 45 to the lower ball bearing, from which it passes into the collecting funnels 47 placed underneath, and from these to the oil holders 48 of the neck bearing 49 constructed in the usual manner, whereby the said bearing is also lubricated through the channels 50.

In the construction of the guide piece 28 illustrated in Fig. 5, an alteration in the support thereof is illustrated inasmuch as in each of the upper and lower disks 29 and 31 there is inserted a contact ring 51, 52, with sufficient side spaces 53, which arrangement has for its object to absorb the side oscillations of the shaft during its revolution. Otherwise the construction is in principle the same as that previously described.

Fig. 6 shows another construction of the bearing in which the balls are replaced entirely by friction rings 54, 55 placed between the disks 29, 30 and 31. As the boss 3 serves as support for the lifting plate 27 one can shake up the mass under operation by lifting it, whereby the instantaneous discharge is effected even in the case of sticky masses. It should further be remarked that the upper ball bearing 32 is only put in operation on the lifting of the ring 30, whereas when the drum is closed it rests upon the said ring and therefore does not share in the rotation.

In the case of Figs. 7 and 9 the opening and closing of the drum is effected by the action of a piston which is displaced in a cylinder by a pressure means of any kind, which acts upon the parts to be moved for the purpose. This piston can be arranged in any convenient manner and at any convenient point, but it is preferably so arranged that intermediate parts are avoided as much as possible. This can be attained by placing the drum not upon a fixed but upon a suspended shaft. An important advantage is thereby secured in that the entire opening and closing mechanism can be placed beneath the drum without being obstructed by the drum shaft. The raising of the cover in this case also is effected by means of the rods 26 passing through the drum with aid of the lifting plate 27. This latter is also in this construction provided with connecting rings at its lower end, between which the stationary ring 30 is arranged. In this manner a convenient connection may be made with the already mentioned piston for effecting the opening and the closure, if between two opposed points of the ring under the ring bearing there is arranged a connection to the

middle of which the cylinder rod can be connected directly. In this arrangement it is especially advantageous to form the connection with the rings by means of the holder 5 101 surrounding the entire annular bearing, which holder may serve at the same time for the collection of the lubricant. To the axis thereof underneath the bottom the piston rod 102 can then be attached directly. The 10 operating cylinder 103 itself is placed in the same axis immediately beneath the ring bearing and rests by means of a socket in a socket bearing. In order to provide for the oscillations of the entire axle transmitted 15 from the drum, the socket pin 104 rests upon a ball 105 and can freely move with it in the spacious socket 106. The bottom of the socket is preferably arched concave according to the radius of oscillation of the axle. 20 The socket bearing itself is fixed by means of the arms 107 to the stationary part of the machine, and the adjustment of the bushes placed therein is effected by means of the set screw 108.

25 In order that the pressure cylinder may not be able to rise on the introduction of pressure fluid above the piston at a slight pressure, and thus cause a diminution of the tightness of the drum cover as regards the 30 bottom thereof, the cylinder is maintained in its uppermost position by means of two or more springs 109. These springs will yield a little in case of need, but must be so proportioned that they possess sufficient 35 strength to maintain the tightness of the drum. The springs do not affect the oscillating motion of the axle but they very effectively prevent too powerful sidewise motion. In order to be able to put the springs 40 under uniform tension they are provided with set screws 110. The supply of the pressure fluid is effected through the pipes 111 and 112. The control is by means of the four-way cock 113.

45 By aid of the device above described the operation is rendered extremely simple. By turning the cock as required, the guide piece 27 can be pressed as often as needful against the drum or against its bottom in order to 50 shake up the mass in the drum, so that even very sticky substances must escape. In the somewhat altered construction illustrated in Fig. 8, the pressure cylinder serves only for lifting or opening the drum while the closing 55 is effected by constantly operative powerful springs 114. These springs are like the springs 109 fixed adjustably to the stationary parts of the mechanism, and engage preferably on the container 101. After the 60 pressure fluid is admitted beneath the piston then the opening of the drum takes place against the pressure of the springs, while on the removal of the pressure the springs alone effect the closure. These latter also

maintain the drum closed throughout the 65 whole working process.

Having now particularly described and ascertained the nature of my said invention and in what manner the same is to be performed, I declare that what I claim is: 70

1. In a centrifugal machine, a centrifugal drum, means for lifting a part of the same during the operation, the same comprising a base plate rigidly connected with the movable part of the drum, a sleeve shaped guide 75 surrounding the drum shaft, a plate having a portion adjustably connected with said sleeve, a top and an intermediate plate, means for preventing rotary motion of the intermediate plate, and means for raising the 80 latter.

2. In a centrifugal machine, a centrifugal drum, means for lifting a part of the same during the operation, the same comprising a base plate rigidly connected with the movable part of the drum, a sleeve shaped guide 85 surrounding the drum shaft, a plate having a portion adjustably connected with said sleeve, a top and an intermediate plate, means for preventing rotary motion of the intermediate plate, means for raising the 90 latter, and balls upon opposite sides of the intermediate plate and contacting with the upper and lower plates.

3. In a centrifugal machine, a centrifugal 95 drum, means for lifting a part of the same during the operation, the same comprising a base plate rigidly connected with the movable part of the drum, a sleeve shaped guide surrounding the drum shaft, a plate having 100 a portion adjustably connected with said sleeve, a top and an intermediate plate, means for preventing rotary motion of the intermediate plate, means for raising the 105 latter, a piston, means for connecting the intermediate plate therewith, a cylinder, and means for actuating the same.

4. In a centrifugal machine, a centrifugal drum, means for lifting a part of the same during the operation, the same comprising a 110 base plate rigidly connected with the movable part of the drum, a sleeve shaped guide surrounding the drum shaft, a plate having a portion adjustably connected with said sleeve, a top and an intermediate plate, 115 means for preventing rotary motion of the intermediate plate, means for raising the latter, a piston, means for connecting the intermediate plate therewith, a cylinder, and 120 means for actuating the same, the drum shaft being suspended.

5. In a centrifugal machine, a drum with perforated walls, means for lifting a portion of said drum, a shield fixed thereto and forming a collecting space around the drum, 125 an annular channel outside said shield, and a tube communicating with said channel for the discharge of the liquid.

6. In a centrifugal machine, a drum with perforated walls, means for lifting a portion of said drum, a shield fixed thereto and forming a collecting space around the drum, an annular channel outside said shield, a tube communicating with said channel for the discharge of the liquid, and an annular widened ledge overhanging into said channel.

In testimony whereof I have signed my name to this specification in the presence of two subscribing witnesses.

HUGO SCHMITZ.

Witnesses:

WM. VANDORN,
GEO. W. BUSEY.