

No. 852,923.

PATENTED MAY 7, 1907.

F. A. BROWNELL.  
CLIP.

APPLICATION FILED MAY 18, 1905.

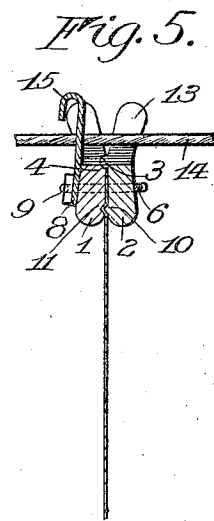
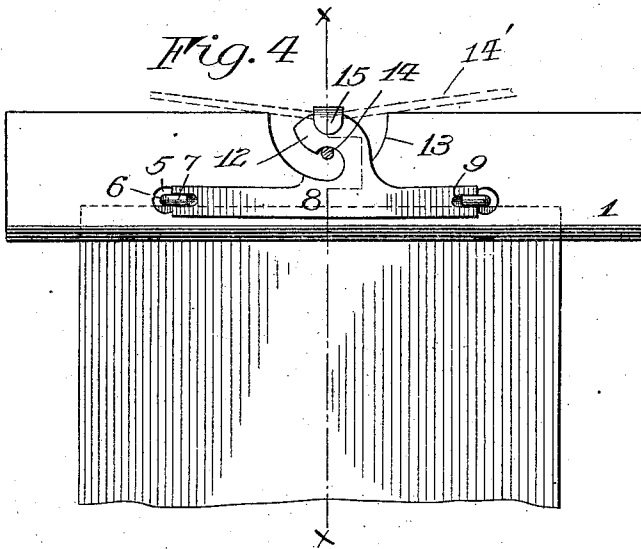
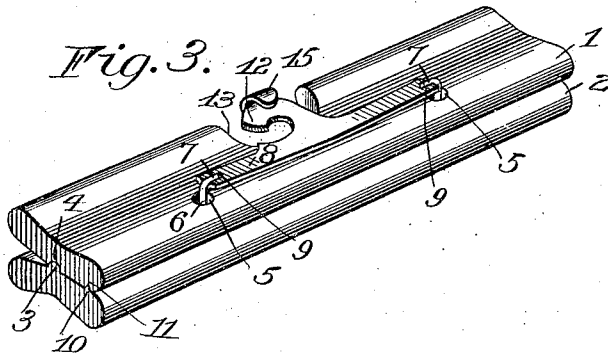
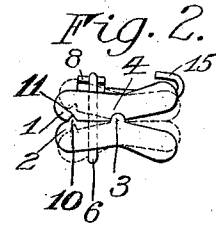
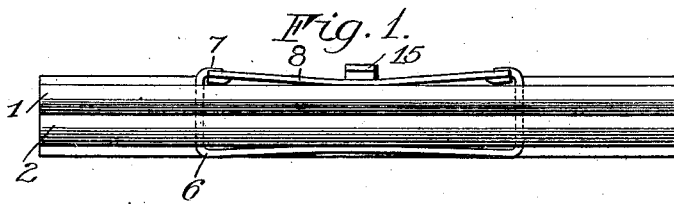

Witnesses  
 M. J. St. Helens  
 C. J. Aldridge

Inventor  
 Frank A. Brownell  
 by Student & Clark  
 his Attorney

# UNITED STATES PATENT OFFICE.

FRANK A. BROWNELL, OF ROCHESTER, NEW YORK, ASSIGNOR TO EASTMAN KODAK COMPANY, OF ROCHESTER, NEW YORK, A CORPORATION OF NEW YORK.

## CLIP.

No. 852,923.

Specification of Letters Patent.

Patented May 7, 1907.

Application filed May 18, 1906. Serial No. 261,083.

*To all whom it may concern:*

Be it known that I, FRANK A. BROWNELL, of Rochester, in the county of Monroe and State of New York, have invented certain new and useful Improvements in Clips; and I do hereby declare the following to be a full, clear, and exact description of the same, reference being had to the accompanying drawings, forming a part of the specification, and to the reference-numerals marked thereon.

My present invention relates to clips for holding small articles and particularly adapted for prints or negatives used in photography and it has for its particular object to provide a means whereby films or prints which have become wet and softened as a result of the developing, washing or toning processes undergone, may be conveniently handled without injury and it embodies generally a spring clip of novel construction which is adapted to grip the work in a particular manner and which includes means for hanging it upon a line in different positions for drying purposes.

To these and other ends the invention consists in certain improvements and combinations of parts all as will be hereinafter more fully described the novel features being pointed out in the claims at the end of the specification.

In the drawings: Figure 1 is a bottom plan view of a clip embodying my invention. Fig. 2 is an end view thereof showing in dotted lines the positions of the jaws when sprung. Fig. 3 is a perspective view. Fig. 4 is a side elevation with a sheet of material retained between the jaws, and Fig. 5 is a cross sectional view on the line  $x-x$  of Fig. 4.

Similar reference numerals in the several figures indicate similar parts.

In the present embodiment of my invention and as best illustrated by Figs. 2, 3 and 5 herein, 1 and 2 indicate the jaws, preferably of non-metallic material as wood, having convex contacted inner faces, one of which is provided with a longitudinally extending tongue 3 operating in a corresponding groove 4 in the other to form an axis on their tangent about which the members are rocked to open or close the bite of the jaws by pressure upon the rear edges as will be understood. At suitable distances each side of the longitudinal center but removed from the center of movement the jaws or members are pro-

vided with apertures 5 between which extends a spring wire 6 bent at right angles to pass through each and having its ends turned down sharply toward each other forming the hooks 7 on the opposite side which hooks engage the ends of a spring plate 8, suitable depressions 9 having been made therein to hold them in place. In the form shown both the plate 8 and the wire 6 forming the spring actuating members are bowed slightly or formed as to normally bear against their respective surfaces in the center only, being drawn flat by the opening of the jaws and forcibly closing the latter by their elasticity when the pressure of the fingers is released. This forms a neat and inexpensive spring of any desired strength, the latter being governed by the thickness or nature of the material used and the extent of curvature of the parts as above noted.

The gripping edges of the jaws are provided with additional means for insuring a firm purchase upon the sheet inserted therein which in the present instance embodies a tongue 10 and groove 11 much like the members 3 and 4 except that they are V-shaped in cross section with the intent of inflicting a sharp crease in the surface they engage to evident advantage. The plate 8 is provided with a lateral extension in the form of a hook 12, the jaws being cut away on their rear edges opposite thereto as indicated by 13 so that it may be slipped over a line 14 when it is desired to hang up the work for drying purposes. This hook 12, in turn, is provided with a downwardly extending ear 15 also intended to offer means for suspension upon a line or cord 14' as shown in dotted lines in Fig. 4 but in a plane perpendicular to that of the other so that the prints or other work may be exposed to the drying agent with either their faces or edges adjacent.

A clip embodying my invention is composed of but four pieces which are simple and cheap of manufacture and easily assembled by hand without the use of any tool whatever.

In the claims:

1. The combination with a clip comprising relatively movable jaws, of a spring-actuating member embodying a strip of elastic material extending along the outer surface of one of said jaws substantially parallel with the axis of movement and bowed to normally

contact said jaw at a point intermediate its ends, and connections between said member and the other jaw.

2. The combination with a clip comprising 5 relatively movable jaws provided with apertures, of a spring-actuating member embodying a strip of elastic material extending along the outer surface of one of said jaws, a member engaging the other jaw and means connecting the said members and extending 10 through the apertures only.

3. The combination with a clip having the relatively movable jaws, of a spring actuating member embodying a strip of elastic material extending along the outer surface of 15 one of said jaws and having its ends passed through apertures in both to bear against the corresponding surface of the other.

4. The combination with a clip having the 20 relatively movable jaws, of a spring actuating member embodying a strip of elastic material extending along the outer surface of one of said jaws and connected with the ends of a resilient plate on the corresponding surface of the other.

5. The combination with a clip having the relatively movable jaws, of a spring actuating member arranged on the outside of one of said jaws, a resilient plate on the outer

side of the other jaw, connections between 30 said member and said plate and a hook on the latter for hanging the clip on a support.

6. The combination with a clip having the relatively movable jaws provided with recesses at their rear edges, of a spring actuating member arranged on the outer side of one 35 of said jaws, a resilient plate on the outer side of the other jaw, connections between said member and said plate, and a hook on the latter extending opposite the recesses in 40 the jaws for hanging the clip on a support.

7. The combination with a clip having the relatively movable jaws, of a plate arranged thereon carrying a hook and an extension on 45 the hook adapted to support the clip in a plane at an angle to that in which it is supported by said hook.

8. In a clip, the combination with the pivotally connected jaws, of spring actuating devices comprising bowed elastic members 50 arranged one on the outer side of each of said jaws and extending axially thereof, and connections between said members.

FRANK A. BROWNELL.

Witnesses:

G. WILLARD RICH,  
RUSSELL B. GRIFFITH.