

(19) World Intellectual Property Organization
International Bureau



(43) International Publication Date
4 May 2006 (04.05.2006)

PCT

(10) International Publication Number
WO 2006/045536 A1

(51) International Patent Classification:
A47J 31/40 (2006.01) B65D 81/00 (2006.01)

CH-1670 Ursy (CH). DENISART, Jean-Paul [FR/CH];
15, Chemin de la Jaque, CH-1093 La Conversion (CH).

(21) International Application Number:
PCT/EP2005/011306

(74) Agent: BORNE, Patrice; 55, avenue Nestlé, CH-1800
Vevey (CH).

(22) International Filing Date: 20 October 2005 (20.10.2005)

(81) Designated States (unless otherwise indicated, for every
kind of national protection available): AE, AG, AL, AM,
AT, AU, AZ, BA, BB, BG, BR, BW, BY, BZ, CA, CH, CN,
CO, CR, CU, CZ, DE, DK, DM, DZ, EC, EE, EG, ES, FI,
GB, GD, GE, GH, GM, HR, HU, ID, IL, IN, IS, JP, KE,
KG, KM, KP, KR, KZ, LC, LK, LR, LS, LT, LU, LV, LY,
MA, MD, MG, MK, MN, MW, MX, MZ, NA, NG, NI, NO,
NZ, OM, PG, PH, PL, PT, RO, RU, SC, SD, SE, SG, SK,
SL, SM, SY, TJ, TM, TN, TR, TT, TZ, UA, UG, US, UZ,
VC, VN, YU, ZA, ZM, ZW.

(25) Filing Language: English

(26) Publication Language: English

(30) Priority Data:
04025320.5 25 October 2004 (25.10.2004) EP

(71) Applicant (for all designated States except US): NESTEC
S.A. [CH/CH]; 55, av. Nestlé, CH-1800 Vevey (CH).

(72) Inventors; and

(75) Inventors/Applicants (for US only): YOAKIM, Alfred
[CH/CH]; 2, ch. de la Routiaz, CH-1806 St-Légier-La
Chiésaz (CH). GAVILLET, Gilles [CH/CH]; Plattiez,

(84) Designated States (unless otherwise indicated, for every
kind of regional protection available): ARIPO (BW, GH,
GM, KE, LS, MW, MZ, NA, SD, SL, SZ, TZ, UG, ZM,
ZW), Eurasian (AM, AZ, BY, KG, KZ, MD, RU, TJ, TM),
European (AT, BE, BG, CH, CY, CZ, DE, DK, EE, ES, FI,

[Continued on next page]

(54) Title: CAPSULE WITH SEALING MEANS

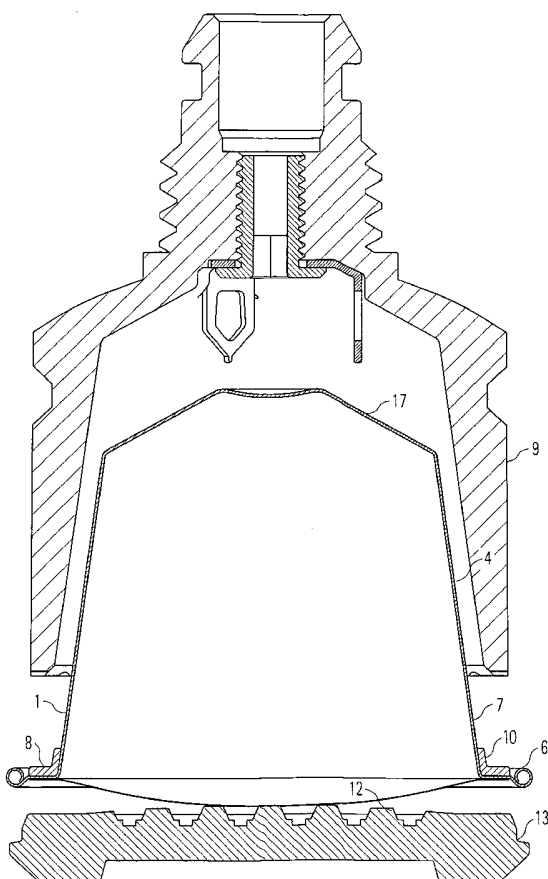

(57) Abstract: A capsule (1) contains beverage ingredients such as ground coffee, tea or other ingredients and is configured for insertion in a beverage production device (2) in order to have a liquid under pressure have enter the capsule (1) and to interact with the ingredients (3) in the capsule (11). The capsule (1) comprises a base body (4) and a foil member (5) closing the base body (4) by being attached to a flange-like rim (6) extending from the side wall (7) of the base body (4) of the capsule (1). The base body (4) of the capsule (1) comprises a resilient sealing member (8), the sealing member (8) being designed to be in sealing engagement with a bell member (9) of the beverage production device (2).

WO 2006/045536 A1



FR, GB, GR, HU, IE, IS, IT, LT, LU, LV, MC, NL, PL, PT, RO, SE, SI, SK, TR), OAPI (BF, BJ, CF, CG, CI, CM, GA, GN, GQ, GW, ML, MR, NE, SN, TD, TG).

— of inventorship (Rule 4.17(iv))

Declarations under Rule 4.17:

- as to applicant's entitlement to apply for and be granted a patent (Rule 4.17(ii))
- as to the applicant's entitlement to claim the priority of the earlier application (Rule 4.17(iii))

Published:

- with international search report

For two-letter codes and other abbreviations, refer to the "Guidance Notes on Codes and Abbreviations" appearing at the beginning of each regular issue of the PCT Gazette.

Capsule with sealing means

The present invention generally relates to capsules for containing beverage ingredients, to a beverage producing system for use in connection with such capsules as well as to methods for producing beverages on the basis of ingredients contained in such capsules.

The background of the present invention is the field of capsules which contain beverage or other comestible (e.g. soup) ingredients. By means of an interaction of these ingredients with a liquid, a beverage or other comestibles, such as for example soups, can be produced. The interaction can be for example an extraction, brewing, dissolution, etc. process. Such a capsule is particularly adapted to contain ground coffee in order to produce a coffee beverage by having hot water under pressure enter the capsule and draining a coffee beverage from the capsule.

A capsule as shown in FR 2160634 relates to an apparatus for making coffee beverage from a cartridge in which a water injection device is placed hermetically against the upper side of the cartridge. The water injection device includes a seal which is applied on the upper rim of the capsule. However, the seal is part of the apparatus.

EP 0361569 A1 does not show a sealed capsule, but a coffee filter unit which is not sealed when placed into the coffee machine but simply press fitted in a cartridge casing, such that water can be poured on a filter paper provided at the open upper side of the coffee filter unit. To avoid spilling of water outside the filter unit's upper rim, the peripheral portion of a filter paper is clamped between the outer rim of the coffee filter unit wall and the surrounding wall of the machine. Such a design is a device which filters a beverage at atmospheric pressure and which is so not adapted to withstand the typical water injection pressure of e.g. more than 3 bars or even much

higher pressure which reigns in the capsule when an espresso-style coffee is produced.

FR 2617389 describes a low cost filter cartridge adapted
5 to be brewed at relatively low pressure in a beverage device. The body of the capsule is entirely made from injection-moulded plastic, preferably polypropylene as the main constituent of the capsule. The capsule has a flange like-rim made of the same material as the main constituent
10 of the capsule which is thus crushed during closure of the device about the capsule. The capsule is combined to a brewing device which is a bayonet-like closure system which applies closure forces on the capsule's rim which depends on the tightening torque applied by the user.
15 Therefore, the capsule's rim is crushed up to a point at which a certain seal effect can be obtained. One problem is that it is not possible with a simple flange-like rim, even with an increase of thickness, made of the same plastic material as the body of the capsule that normally
20 requires a sufficient rigidity, to provide a seal effect which is sufficient to stop water or maintain a controlled internal pressure level, at the elevated relative pressure of extraction; i.e., within a pressure range sufficient to deliver an espresso-like coffee with crema. Furthermore,
25 most modern beverage machines have closure devices that close at a predefined closure force and do not depend on the user's force therefore requiring an adaptation of the seal to the machine and not the opposite.

30 Systems and methods for obtaining fluid comestibles from substances containing capsules are for example known from EP-A-512470 (counterpart of US 5,402,707).

The capsule 101 as shown in Fig. 1 has a frustroconically-
35 shaped cup 102 which may be filled e.g. with roasted and ground coffee 103 and which is closed by a foil-like tear face cover 104 welded and/or crimped to a flange-like rim which extends laterally from the side-wall of cup 102. A

capsule holder 111 comprises a flow grill 112 with relief surface element members 113.

The capsule holder 111 is accommodated in its support 115
5 which has a lateral wall 124 and a bore 127 for the passage of extracted coffee beverage.

As can be seen from fig. 1 the extraction system further
10 comprises a water injector 107 having a water inlet channel 120 and an annular element 108 with an internal recess of which the shape substantially corresponds to the outer shape of the capsule. On its outer part, the annular member 108 comprises a spring 122 holding a ring 123 for releasing the capsule on completion of extraction.

15 In operation, a capsule 101 is placed in the capsule holder 111. The water injector 107 perforates the upper face of the cup 102. The lower tear face 104 of the capsule rests on the radially arranged members 113 of the
20 capsule holder 111.

The water is injected through the channel 120 of the water injector 107 and impinges on the bed 103 of coffee. The pressure in the capsule 101 increases and the tear face
25 104 increasingly follows the shape of the radial opening relief members 113. Such radial opening relief members could be replaced by pyramid-shaped reliefs or other shapes of relief. When the constituent material of the tear face reaches its breaking stress, the tear face tears
30 along the relief members. The extracted coffee flows through the orifices of the flow grill 112 and is recovered in a container (not shown) beneath the bore 127.

The principles of this extraction process as far as it can
35 be maintained in connection with the present invention can be summarized as follows:

- An initially sealed capsule is inserted in capsule holder means;

- 5 - The capsule holder means is then introduced associated to the water injection means of the machine such that an annular element (108 in Fig. 4) surrounds the sealed capsule.

- In a first wall of the capsule at least one opening is generated.

- 10 - Water entering the capsule through the opening in the first wall is interacting with the ingredients contained in the capsule while traversing the interior of the capsule and is then made to leave the capsule through at least one opening/perforation
15 created in the second wall.

The ingredients in the capsule constitute the "bottleneck" of the flow path of the water and will therefore cause a pressure drop between the upstream and the downstream side
20 of the liquid flow through the capsule, which pressure drop will even increase during the interaction between the liquid and the ingredients for example due to a swelling of the ingredients. Correspondingly it has to be assured that the only water flow is actually taking place through
25 the interior of the capsule (arrow A1) and that no water can flow from the water injector into the interstice between the annular enclosing member 108 and the exterior of the capsule 101 and then to the draining bore 127 of the device. The arrow A2 illustrates this undesired water
30 flow path. With other words, any water flow exterior to the capsule 101 has to be stopped by a sealing engagement being positioned in the interstice between the annular member 108 and the capsule 101 and in the flow path between the water injector and the beverage-draining bore.
35 In the embodiment as shown in Fig. 1 such sealing engagement can be achieved at least to a certain degree by the pinching engagement between the annular member 108, the flange-like rim of the side wall of the capsule 101 and the capsule holder.

In case the sealing engagement is not working properly and water is flowing outside the capsule, no pressure sufficient to cause the tearing of the tear face will be built up inside the capsule or, alternatively, the pressure will be causing no complete tearing of the tear face and therefore a poor extraction of the substance. In such a scenario water will be drained from the beverage production device without having interacted or fully interacted under sufficient pressure conditions, with the ingredients contained in the capsule.

An improvement could be thought of according to which this sealing engagement is further improved by lining the inner wall of the annular member with a rubber-elastic material. With other words, according to said approach the sealing engagement is assured by structures fixed to or attached with the beverage-producing device. This has disadvantages in that after the use of a substantial number of capsules a wearing off of the fixed sealing means can take place such that the quality of the produced beverage is increasingly deteriorated by water passing the no longer properly efficient sealing.

Any „leak,, at the exterior of the capsule reduces the pressure build-up inside the capsule. On the other hand, it is well known that a sufficient extraction pressure is a key factor for the quality of espresso-style coffee.

The present invention correspondingly aims at an improvement of the sealing engagement positioned between the liquid inlet and the beverage draining side of such a beverage production system.

It is thereby the central idea of the present invention to transfer a resilient part of the sealing engagement from the beverage production device to the capsule. The advantage is that any resilient sealing member is only used once (i.e. only with the associated capsule) such

that a proper functioning of the sealing can be assured and no hygienic problems can occur at the sealing member.

Note that the present invention thus especially aims at an improvement of the capsules, such that state-of-the-art beverage production devices with built-in sealing means as for example shown in EP-A-512470 can also be used in connection with a capsule according to the present invention.

10

The object is achieved by means of the features of the independent claims. The depending claims develop further the central idea of the present invention.

15 According to a first aspect of the present invention a capsule for containing beverage (or other liquid comestibles) ingredients is proposed. The capsule is designed for insertion in a beverage production device in order to have a liquid under pressure have enter the capsule and to interact with the ingredients in the capsule. According to the invention the outer surface of the capsule comprises a resilient sealing member being structurally arranged to be in a sealing engagement with at least a matching pressing surface of the beverage production device.

25

The resilient sealing member of the capsule is deformed when the capsule is put in sealing engagement with the enclosing member of the beverage production device. The deformation leads to an initial biasing of the sealing member against the enclosing member.

30

The sealing member can thereby be resilient due to its shape and/or the material used.

35

The sealing member can be bendable so that it can exert a biasing force against the matching pressing surface of the beverage production device.

The sealing member can also be compressible so that the sealing engagement is obtained by the pressing surface of the beverage production device exerting a positive pressure force on the sealing member, from a first
5 uncompressed thickness of the capsule to a second compressed thickness of the member.

The sealing member can be made integral to the capsule or be associated as a separate piece to the capsule. In the
10 latter case the sealing member can be removable or, alternatively, can be fixedly connected to the capsule.

The sealing member can for example have the shape of an O or L-shaped ring.

15 The sealing member can be attached to the capsule using an adhesive or by (thermal or ultrasonic) welding. Alternatively the sealing member can be held in position surrounding the capsule due to its inherent material
20 tension or stretching characteristics. In another possible embodiment, the sealing member may be pinched by the capsule material.

The capsule can be made of plastics or a metal such as
25 e.g. aluminum.

According to another aspect of the present invention a capsule is proposed having a base body and/or foil member made of plastics material, wherein at least a portion of
30 the base body is designed to be perforated when properly placed in the beverage production device.

According to another aspect a beverage producing system is proposed comprising such capsule and a beverage production
35 device.

According to a further aspect of the present invention the method for producing a beverage is proposed in which a pressure-tight sealing engagement of an element of the

beverage production device and a sealing member of the capsule assures that the only liquid medium flow path between the perforated opening in the top wall of the cup-like base and the opening in the foil member traverses the interior of the capsule.

Another aspect of the present invention relates to a beverage producing method according to which both in the base body and the foil member of such capsule, both being made of plastics, perforations are generated.

The term "matching pressing surface" as used herein is typically a portion of the beverage production device. This can be a surface of the enclosing member which is typically one part of the device which covers at least one side of the capsule upon closing of the device to encompass the capsule.

Further advantages, features and objects of the present invention will become evident for the man skilled in the art when reading the following detailed description of embodiments of the present invention taking in conjunction with the figures of the enclosed drawings.

Fig.1 shows an extraction capsule known from EP-A-512470,

Fig. 2 shows a first embodiment of the present invention in which a capsule is placed on the capsule holder but has not yet reached its closing position in the beverage production device,

Fig. 3 shows an enlarged in view of Fig. 2

Fig. 4 shows the first embodiment in a state, in which a capsule has reached its closing position between a bell member and the capsule holder,

5 Fig. 5 shows a perspective view of a capsule holder, a bell member and a capsule according to the first embodiment in a position in which the capsule has not yet reached its closing position,

10 Fig. 6 shows a second embodiment of the present invention,

Fig. 7 is an enlarged view of a detail of Fig. 6,

15 Fig. 8 is a perspective view of the second embodiment,

Fig. 9 shows the second embodiment in a state in which the capsule has reached its closing position,

20 Fig. 10 shows a third embodiment in which the sealing member of the capsule is part of the side wall of the capsule

25 Fig. 11 is a detailed view of Fig. 10,

Fig. 12 shows the sealing engagement according to the third embodiment,

30 Fig. 13 shows a fourth embodiment in which the sealing member is part of the top wall member of the capsule, and

35 Fig. 14 shows the fourth embodiment in the final state.

With reference to Fig. 2 now a first detailed embodiment will be explained.

Note that in the following the invention will be explained referring to a certain design of a capsule, i.e. a design according to which the capsule comprises a cup-like base body and a closing foil member. However, it is to be understood than other designs of the capsule are viable, such as e.g. capsules having an inverted cone or a lenticular form with two essentially matching and opposing walls (e.g. foils) being sealed at the e.g. ring-shaped edge. Generally a capsule according to the present invention comprises at least two opposing wall members which are connected to each other at the edges to form a sealed flange-like rim area, thus enclosing a sealed interior.

Comparable to the prior art also this embodiment shows a capsule holder 13 having relief elements 12 which are designed to tear and perforate a foil member 5 closing off a cup-like base body 4 of the capsule 1. This tearing of the foil member can e.g. occur as soon as the pressure inside the capsule exceeds a threshold value. The word "tearing" includes actions such as breaking, cutting or puncturing as well as typical tearing by stretching the material beyond its tensile strength. Note that the relief elements can have any protruding shape able to cause a (partial) tearing of the foil member. As an example only pyramids, needles, blades, bumps, cylinders, elongated ribs are cited.

Within the capsule 1 ingredients 3 are contained, wherein the ingredients 3 are selected such that a beverage can be produced when having a liquid entering the capsule in the region of the top wall 17 of the capsule 1 and then interact with such ingredients 3. Preferred ingredients are e.g. ground coffee, tea or any other ingredients from which a beverage or other liquid or viscous comestible (e.g. soup) can be produced.

Fig. 2 shows a state in which such a capsule has been placed on a capsule holder 13, the foil member 5 resting

on the relief element 12 side of the capsule holder 13 and the cup-like base body 4 of the capsule 1 being already partly surrounded by the circumferential wall 25 of an enclosing member 9 of the beverage production device. The
5 shown enclosing member has the shape of a bell. Other shapes are viable, wherein the design of the interior contours (recess) of the enclosing member is generally adapted to substantially match the contours of the capsule 1.

10

Note that the foil member 5 as shown is not exactly flat due to a defined over pressure inside the capsule, which over pressure is generated by introducing e.g. a protective gas when producing the filled capsule.

15

The capsule can also include one of more inner filters. A bottom filter can be placed in contact with the inner surface of the foil 5 and/or a top filter can be placed at least partially in contact with the inner surface of the
20 body 4.

In another mode, the capsule can also have foil member 5 which is flat or even curved inwardly toward the interior of the chamber and that deforms at a certain amplitude as
25 a response to the pressure exerted inside the chamber during the extraction process.

The enclosing (bell) member 9 furthermore comprises an annular support skirt 18, the function of which will be
30 explained later, an external thread 19 for mounting the bell member in a beverage production device and a water inlet opening 20 for feeding a liquid such as for example hot water under pressure to a water injector 14 which is releasable mounted (screwed) to the bell member 9.

35

Note that the thread 19 is just an example for connection means, be it releasable or permanent connection means.

The other components of the beverage production device, such as e.g. the mechanism for displacing the bell member and eventually also the capsule holder are known from the prior art in the field of capsule-based espresso machines.

5

The water injector comprises a perforation element (blade, pin, etc.) 24 designed to produce an opening in the top wall 17 of the capsule 1 when the capsule holder 13 and the bell member 9 are moved close together e.g. by a manually operated or an automatic mechanism. A channel (not shown in the drawings) traverses the perforation element 14 such that water can be fed to the interior of the capsule 1 once the perforation element 14 protrudes into the interior of the capsule 1.

15

The capsule 1 comprises said top wall 17, a sidewall 7 and a flange-like rim 6 with a clamping portion 29, wherein the foil member 5 is sealed to said flange-like rim 6 to close-off hermetically the cup-like base body 4 of the capsule 1. Again, other designs for the capsule are possible as long as the capsule can be sealed and contain the mentioned ingredients.

According to the present invention the outer surface of the capsule 1 presents a dedicated sealing member 8. The sealing member 8 can be resilient due to the material used and/or due to the geometrical shape of the sealing member 8.

Further on, the sealing member 8 can be integral to the capsule 1 or a separate piece. In the latter case the sealing member can be mounted releasably to the base body 4 or fixed thereto e.g. by welding or by means of an adhesive.

35

In case the sealing member 8 is a separate piece attached to the capsule 1, it can be mounted to the capsule as one integral piece. Alternatively it can be applied in fluid or viscous form and then can harden (e.g. polymerize) once

applied onto the outer surface of the capsule, which is the case e.g. when applying silicone.

If a resilient material is used for the sealing member 8, preferably rubber-elastic materials are used. The term "rubber-elastic" means any suitable material having rubber elasticity including but not limited to elastomers, silicones, plastics, latex, balata or others.

Particularly suitable materials for the seal member 8 are: EPDM (Ethylene Propylene Diene Monomer), NBR (Acrylic Nitrile Rubber), TPE (thermoplastic elastomer) or silicone rubber. These materials have particular good flex, compressive properties and can resist high temperatures without cracking.

In case the material of the sealing member is the same as the one used for the capsule (e.g. a metal such as aluminum or plastics), preferably the resilient nature of the sealing member is procured by the geometrical shape of the sealing member.

In the embodiment according to Fig. 2 the sealing member 8 is resiliently deflectable due to the lip-shaped form. It prolongs the clamping portion 29 of the flange-like rim but it is not supposed to be clamped so as to be able to deflect freely under pressure. It is made from the same material as the capsule, preferably plastics. It can be an integral piece of the base body 4 of the capsule 1.

The clamping portion 29 of the flange-like rim is configured to form an annular surface that is clamped at least partially by the matching surfaces of the beverage production device. As a result, the sealing member 8 is released from the forces or stresses that can apply as a result of the tearing of the foil member 5 onto the relief elements 12.

The flexible free lip 8 extends from the outer edge of the

flange-like rim 6 and is inclined outwards. In the shown embodiment the flexible lip is the edge of the side walls of the base body of the capsule, which edge is bent by an angle A (relative to the flat clamping portion of the flange-like rim or sealing plane P) of more than about 90
5 degrees, preferably comprised between 95 and 175 degrees.

Note that such deflectable sealing member 8 can be placed at any position onto the capsule 1 as long as the position
10 is adapted for an exterior sealing engagement of the sealing member 8 and the enclosing member 9 between the water injector 14 and the perforations in the foil member 5. The sealing member 8 can also be provided on the region of the top wall 17 of the capsule 1 surrounding the water
15 injector 14 when the water injector 14 is in a position protruding into the interior of the capsule 1. The sealing member 8 can also be arranged to cover different portions (bottom, side wall, flange-like rim) of the capsule.

20 As can be seen in detail in Fig. 3, the bell member 9 according to this embodiment does not comprise any dedicated resilient sealing member. However, the bell member optionally can also comprise a resilient sealing member.

25 An inclined sealing surface 15 of the bell member 9 is designed to cooperate with the resiliently deflectable sealing member 8 of the capsule 1. The sealing surface 15 is inclined toward the free flexible lip constituting the sealing member. In particular, the sealing surface 15
30 forms preferably an angle B relative to the sealing or closure plane P, when measured in the inward direction of the capsule, of 90 degrees or less. Preferably, the angle B is of from 85 to 50 degrees.

35 Depending on the form and material of the sealing member 8 of the capsule 1, the cooperating surface of the bell member 9 can have any shape, position and orientation

which are adapted for a sealing engagement with the sealing member 8 of the capsule 1.

Upon closing of the device about the capsule, as shown in
5 Fig. 4, the bell member 9 and capsule holder 13 clamp together the capsule along the clamping portion 29 of the flange-like rim. For this the bell member 9 can include one or more annular raising portions that firmly pinch or clamp the clamping portion 29 of the capsule onto a
10 receiving portion surface 31 of the capsule holder. The clamping portion can further form an indent that is complementary an indentation of the surface 31. Therefore, an annular chamber 32 is formed as resulting from the assembly in closure of the bell member 9 and capsule
15 holder 13 that encloses the sealing member 8. As a result the capsule is firmly held in place and tensile forces are released at the free lip that can deflect freely in the chamber toward the inclined surface 15 whereby a perfect watertight sealing can be obtained.

20 Fig. 4 shows the state in which the bell member 9 and the capsule holder 13 are brought in closing pressure engagement and due to the water entering the interior of the capsule and building up a pressure there the pyramidal relief members 12 of the capsule holder 13 have already
25 produced openings in the foil member 5 of the capsule 1. Upon insertion of the capsule the blade element 24 of the water injector 14 creates a perforation 16 in the top wall 17 of the capsule 1. When a sufficient pressure of fluid has been built inside the capsule, the beverage produced
30 from the ingredients contained in the capsule can be drained in small interstices between the relief members 12 and the surrounding foil member 5.

In the state shown in Fig. 4 the resiliently deflectable
35 sealing member 8 of the capsule 1, i.e. the flexible lip, is biased against the corresponding inclined sealing surface 15 of the enclosing member 9. The annular support skirt 18 now covers the end of the flange-like rim 6 of the capsule 1 while the clamping portion 29 is clamped

between surfaces 30, 31 of the device to ensure that the sealing member 8 and the capsule as such remain in position when the sealing surface 15 of the bell member exerts a certain pressure force of the sealing member 8.

5

Actually, the lip-shaped sealing member 8 represents an example of a construction for providing a self-reinforcing sealing engagement. Water coming from the water injector will be pressurized within the interstice between the exterior of the capsule and the enclosing member and will eventually arrive at the lip-shaped sealing member. The lip-shaped sealing member will block the water flow as it is biased against the sealing surface of the annular member. This blocking effect will lead to the pressure raising at the upstream-side of the sealing member which in turn will lead to the sealing member being pressed even stronger against the sealing surface and thus to a sealing engagement which is the stronger the higher the pressure at the sealing engagement.

10

In the embodiment of Fig. 5 grooves 22 are provided in the circumference of capsule holder 13, which grooves 22 act to evacuate water which could settle or accumulate on the upper surface of the capsule holder 13 or dripping out of the capsule before the capsule has been removed.

15

Fig. 6 shows an embodiment essentially corresponding to a variant of the first embodiment of Fig. 2. The sealing member 8 according to this embodiment is compressible. It covers both a portion of the side wall 7 and the area between the outer end of the flange-like rim 6 of the capsule 1 and said side wall 7. (The sealing member can also cover only a portion of the side wall 7 of the base body 4 of the capsule 1.) The sealing member 8 according to this embodiment has a non-symmetrical, i.e. L-shaped cross-section. The sealing member can be made of a material that is more resilient than the material of the base body. In particular, the sealing member can have a

20

25

30

35

hardness that is lower than the hardness of the material of the base body 4 of the capsule.

The sealing member is preferably a rubber-like material. Particularly suitable materials are: EPDM (Ethylene Propylene Diene Monomer), NBR (Acrylic Nitrile Rubber), TPE (thermoplastic elastomer) or silicone rubber. These materials have particular good flex, compressive properties and can resist high temperatures without cracking.

Alternatively, the sealing member 8 can have other shapes such as e.g. a film applied to the capsule, an O-ring, etc.

When the capsule 1 is in a position as shown in Fig. 4 and then, after having finished the beverage production process, the holder 13 is opened, there is a risk that the capsule 1, instead of falling down, remains sucked into the bell member 9 due a "vacuum effect". As shown in Fig. 8 the invention proposes to provide for a mechanism which assures that the type sealing engagement between the capsule 1 and the bell member 9 is only present as long as the bell member 9 is engaged against the capsule holder 13, but automatically released such that air can get into the space between the top wall 17 and the side walls 7 of the capsule 1 and the inner wall of the bell member 9, respectively.

As can be seen from Fig. 8, especially in case the sealing member 8 covers a portion of the side walls 7 of the capsule 1, the annular front surface of the bell member 9 can be provided with grooves 21 which, act as air inlet passage for feeding air. The grooves allow the intake of air once the biasing force between the bell member 9 and the capsule holder 13 is released. Air is thus flowing into this space and it will be easier for the user to take

out the capsule 1. Eventually, the capsule 1 will even automatically fall down from the bell element 9.

Fig. 9 shows the state of the second embodiment in which the front surface 23 of the bell member 9 is in sealing engagement with the sealing member 8 of the capsule 1.

Figures 10 to 12 show a third embodiment of the present invention in which the resilient nature of the sealing member is due to the geometrical hollow shape of the capsule itself. In the depicted embodiment the sealing member has the shape of a step 26, i.e. a sudden increase of the diameter of the side wall 7 of the capsule 1. Therefore, the sealing member forms a hollow deflectable and compressible structure sufficient to deform under the closure forces applied by the bell-shaped member onto the capsule holder 13. Note that the geometrical form is not limited to the shown step and other forms are viable as long as they procure a resilient or at least deformable nature of the sealing member.

The step-like sealing member 26 according to this embodiment is only one example for a hollow sealing member (in contrast e.g. to the "filled" sealing member 8 according to the second embodiment, figures 6 to 9). When the resiliency of the sealing member is procured by the geometrical hollow shape, usually a deflection of the sealing member occurs (here: inwards and downwards deformation of the step). On the other hand, when the resilient nature is due to the material used and a "filled" sealing member is used, usually a compression and/or displacement of the material occurs. Preferably, the material for the capsule will be chosen amongst polymeric materials having deflectable and resilient properties.

The sealing surface 15 according to this embodiment is inclined. Thus the sealing pressure has a first component being directed radially inside and another component being directed axially (downwards in figure 12).

5

As can be seen especially from figure 12, the foil member 5 can be wrapped (see reference 27) over the rim of the capsule.

10 Fig. 13 and Fig. 14 show a fourth embodiment in which the sealing member is an O-ring 11. The O-ring is geometrically arranged and, preferably fixed, on the top wall 17 of the capsule 1. This is just an example of providing a sealing member at the exterior of the capsule
15 1 at the side which faces the water injector and which will be perforated in order to create the water inlets to the capsule 1.

The O-ring 11 is positioned to peripherally surround the
20 area in which the water injector 14 perforates the top wall 17 of the capsule 1. The sealing member 11 is thus compressed by the bottom 28 of the enclosing member 9 and (see figure 14) secured in place by the upper end of the circumferential side wall 25 of the enclosing member 9.

25

Note that the bottom 28 can be substantially flat or inclined to ensure a sufficiently water-tight interface with the sealing member 11 when the capsule is fully engaged in the enclosing member 9 at closing of the
30 device.

As an alternative to the O-ring 11, also a deflectable lip-like sealing member (e.g. comparable to the lip 8 according to the first embodiment, see figure 2) can be
35 placed protruding from the top wall 17 of the capsule 1, i.e. the wall facing the water injector 14.

In any case, the bottom 28 will exert an axial compression force on the sealing member 11.

In case e.g. an O-ring is placed on the side wall 7 of the capsule 1, the radial component of the compression force will prevail.

In an alternative, the foil member 5 could be replaced by a wall that can be pierced against at least one relief element before water is injected in the capsule, for instance, as resulting of the closure of the machine about the capsule.

Claims:

1. A capsule for containing beverage ingredients, the
5 capsule (1) being designed for insertion in a beverage
production device (2) in which a liquid under pressure
enters the capsule (1) in order to interact with the
ingredients (3) in the capsule (1) and to drain a
10 beverage from the capsule (1), the capsule has a sealing
member (8, 11, 26) on the outer surface of the capsule
(1) characterized in that the sealing member (8) is
configured to be compressible in sealing engagement with
at least a matching pressing surface of the beverage
15 production device (2) and wherein the sealing member (8)
is resilient.
2. The capsule according to any of the preceding claims,
characterized in that the sealing member (8,26) is
20 resilient due to its shape.
3. The capsule according to claim 1 or 2,
characterized in that the sealing member is arranged to
exert a biasing force against the matching pressing
25 surface of the beverage production device.
4. The capsule according to any of the preceding claims,
characterized in that the sealing member (8, 11, 26) is
compressible and resilient due to the constituent
30 material.
5. The capsule according to any of the preceding claims,
characterized in that the sealing member (26) has a
hollow deflectable structure.
- 35 6. The capsule according to claim 4 or 5,
characterized in that the sealing member (8, 11, 26) is

designed to compress from a first uncompressed thickness to a second compressed thickness.

7. The capsule according to any of the preceding claims,
5 characterized in that the sealing member (8, 11) is made of a material other than the material of the rest of the capsule (4, 5).
8. The capsule according to claim 7, characterized in that
10 the sealing member (8) is made of a material having a lower hardness than the material of the rest of the capsule (4, 5).
9. The capsule according to any one of claims 6 to 8,
15 characterized in that the sealing member (8, 11) is made of a rubber-elastic material.
10. The capsule according to claim 9, characterized in
20 that the rest of the capsule (4, 5) is made of non-rubber elastic material and/or metal such as aluminium.
11. The capsule according to any one of claims 1 to 5,
25 characterized in that the sealing member (8, 26) is made from at least one of the constituent material(s) of the rest of the capsule (4, 5).
12. The capsule according to any of the preceding claims,
30 characterized in that it is comprised of a first and a second wall element being connected with each other in an gas-tight fashion in a flange-like rim area in order to create a sealed interior for the ingredients.
13. The capsule according to any one of claims 7 to 10,
35 characterized in that the sealing member (8) is provided at least in the transition area (10) of the flange-like rim (6) and one of the wall elements.

14. The capsule according to any one of claims 7 to 10,
characterized in that the sealing member (8,11) is
provided on a wall between the flange-like rim and the
location on the capsule where the water injector is
5 introduced.
15. The capsule according to any one of the preceding
claims, characterized in that the capsule (1) comprises
a cup-like base body (4) and a closure member (5).
10
16. The capsule according to claim 15,
characterized in that the sealing member (8) is present
both on the flange-like rim (6) and a portion of a side
wall (7) of the base body (4).
15
17. The capsule according to claim 11,
characterized in that the sealing member (8, 26) is an
integral part of one of the wall elements (4, 5).
- 20 18. The capsule according to any one of claims 6 to 10,
characterized in that the sealing member (8, 11) is a
piece different from the wall elements (4, 5) of the
capsule.
- 25 19. The capsule according to claim 18,
characterized in that the sealing member (8, 11) has the
shape of an O-ring (11).
- 30 20. The capsule according to claim 19, characterized in
that the sealing member has a L-shaped cross-section.
21. The capsule according to any one of claims 18 or 20,
characterized in that the sealing member (8, 11) is
attached to one of the wall elements (4, 5) using an
35 adhesive or by welding or by pinching or crimping or a
combination thereof.

22. A beverage producing system, comprising a capsule
(1) according to any of the preceding claims and a
beverage production device, the beverage production
device having an enclosing member (9) adapted to be
5 selectively in sealing engagement with the sealing
member (8, 11, 26) of the capsule (1).

23. The system according to claim 22,
wherein the sealing engagement is only effective as long
10 as the enclosing member (9) exerts a minimum pressure on
the capsule (1), but is automatically released as soon
as the pressure falls below said minimum pressure.

24. The system according to claim 23,
15 wherein grooves (21) are provided in the
circumference of the enclosing member (9), which grooves
(21) act as air inlet passages for feeding air through
these grooves (21) and through the released sealing
engagement between the capsule (1) and the enclosing
20 member (9).

25. The system according to any one of claims 22, 23 or
24, wherein the enclosing member (9) comprises additional
sealing means adapted to assist to the sealing engagement
25 between the enclosing member (9) and the capsule (1).

26. The system according to any of claims 20 to 23,
wherein the sealing pressure acting at the sealing
engagement has a radial an/or axial component relative to
30 the center axis of the capsule (1).

27. A method for producing a beverage, the method
comprising the following steps:
- providing a capsule containing ingredients and
35 comprising a first wall member (4) and a second wall
member (5) sealed to each other by a flange-like rim (6),
- positioning the capsule (1) in a beverage production

device and producing at least one opening both in the first and the second wall member (4, 5),
- having a liquid enter the capsule (1) at the least one opening in the first wall member (4) and having the liquid
5 leave the capsule (1) through at least one opening in the second wall member (5),
wherein the opening in the first wall member (4) is separated from the opening in the second wall member (5) by a pressure-tight sealing engagement of an element of
10 the beverage production device and a sealing member (8, 11, 26) of the capsule (1), such that the liquid can only flow through the capsule (1), but not at the exterior of the capsule (1).

15 28. The method according to claim 27, characterized in that the pressure-tight sealing engagement is caused by the sealing member (8, 11, 26) of the capsule (1) and that such sealing engagement is not present when using a capsule (1) without such sealing
20 member (8, 11, 26).

29. A beverage or other comestible, produced according to a method according to any of claims 27 or 28.

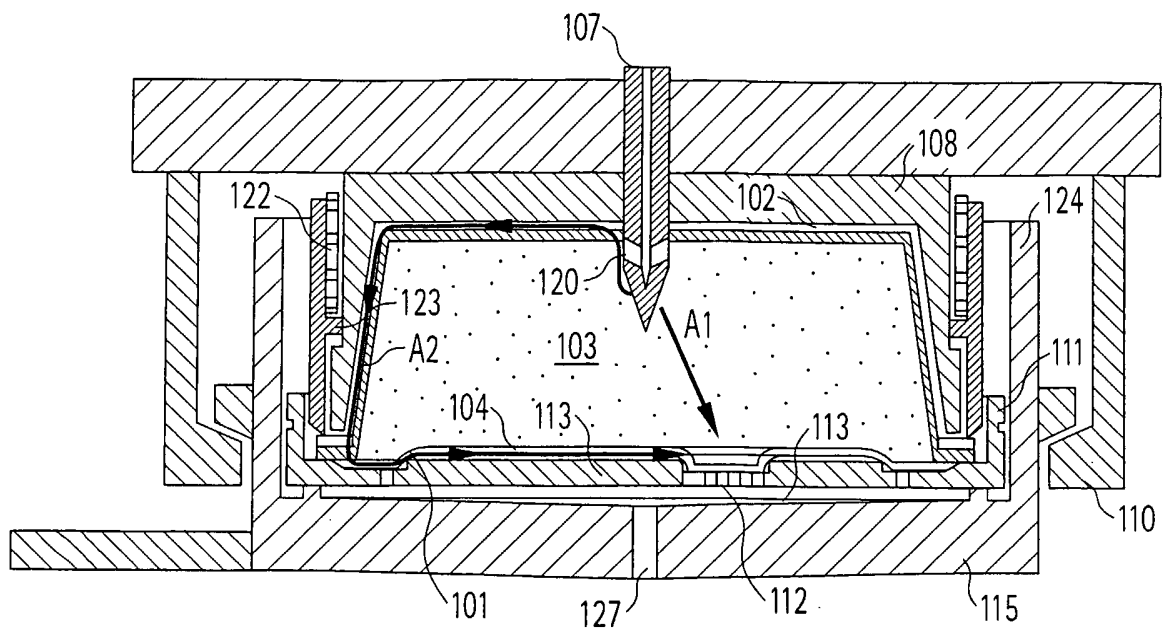

Fig. 1

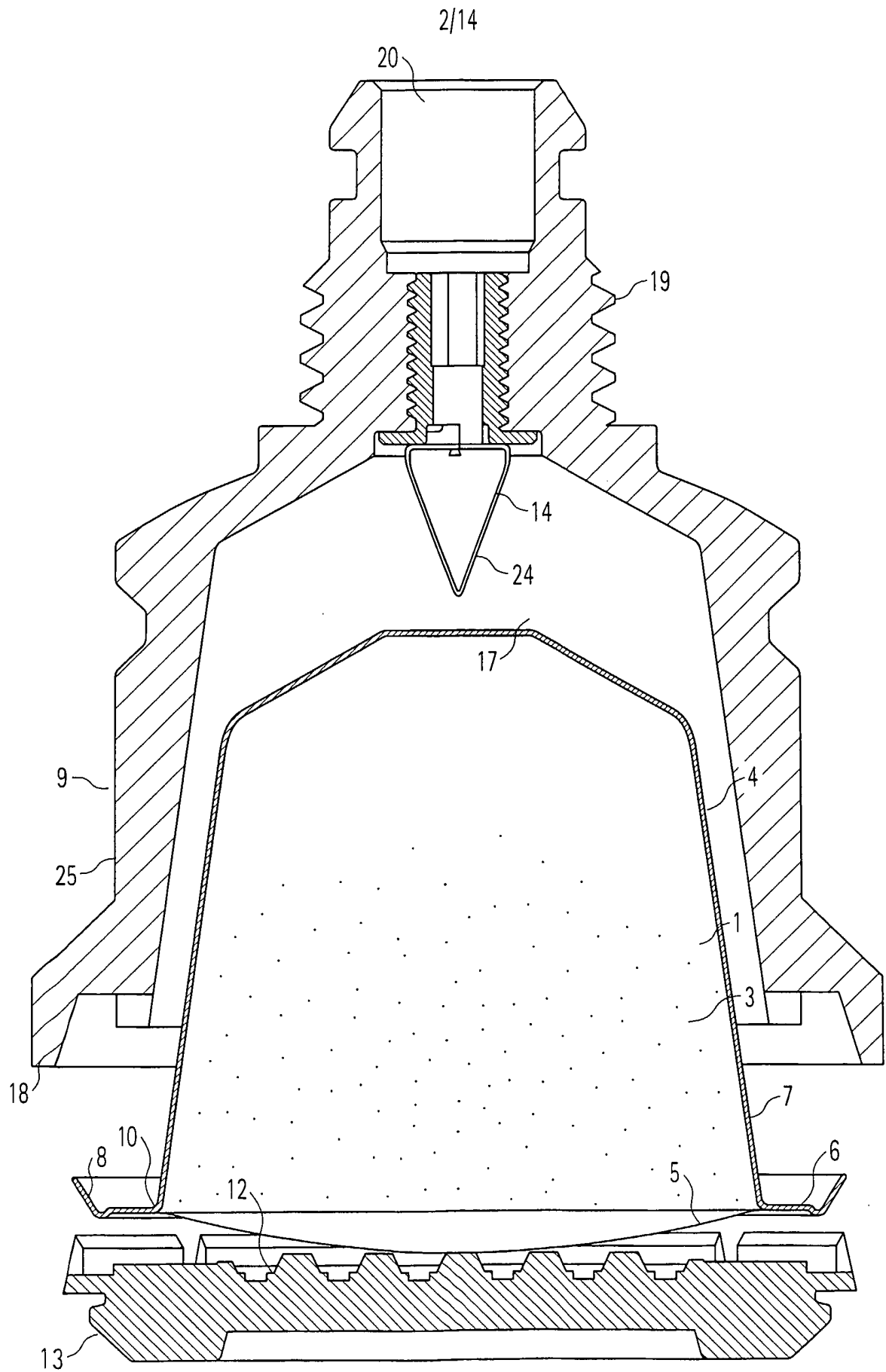

Fig. 2

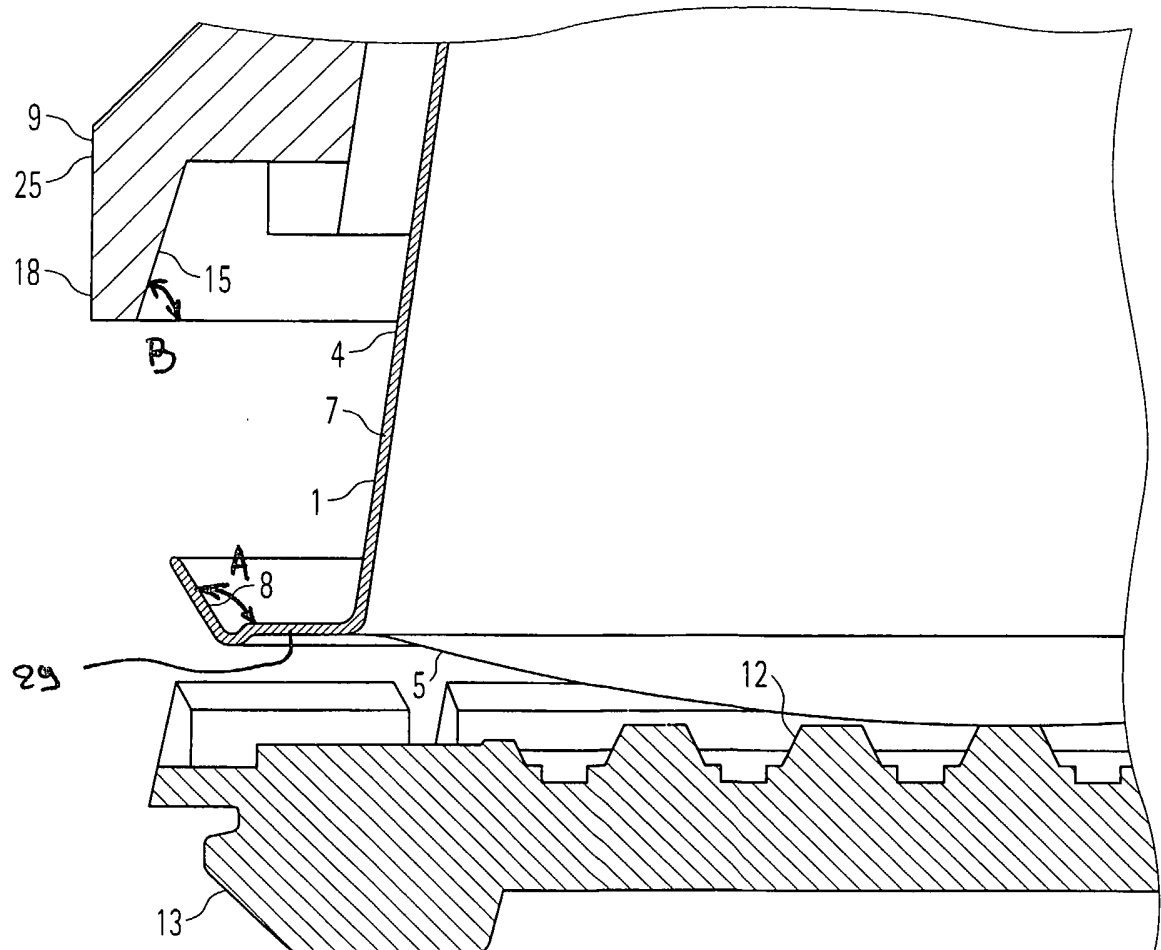
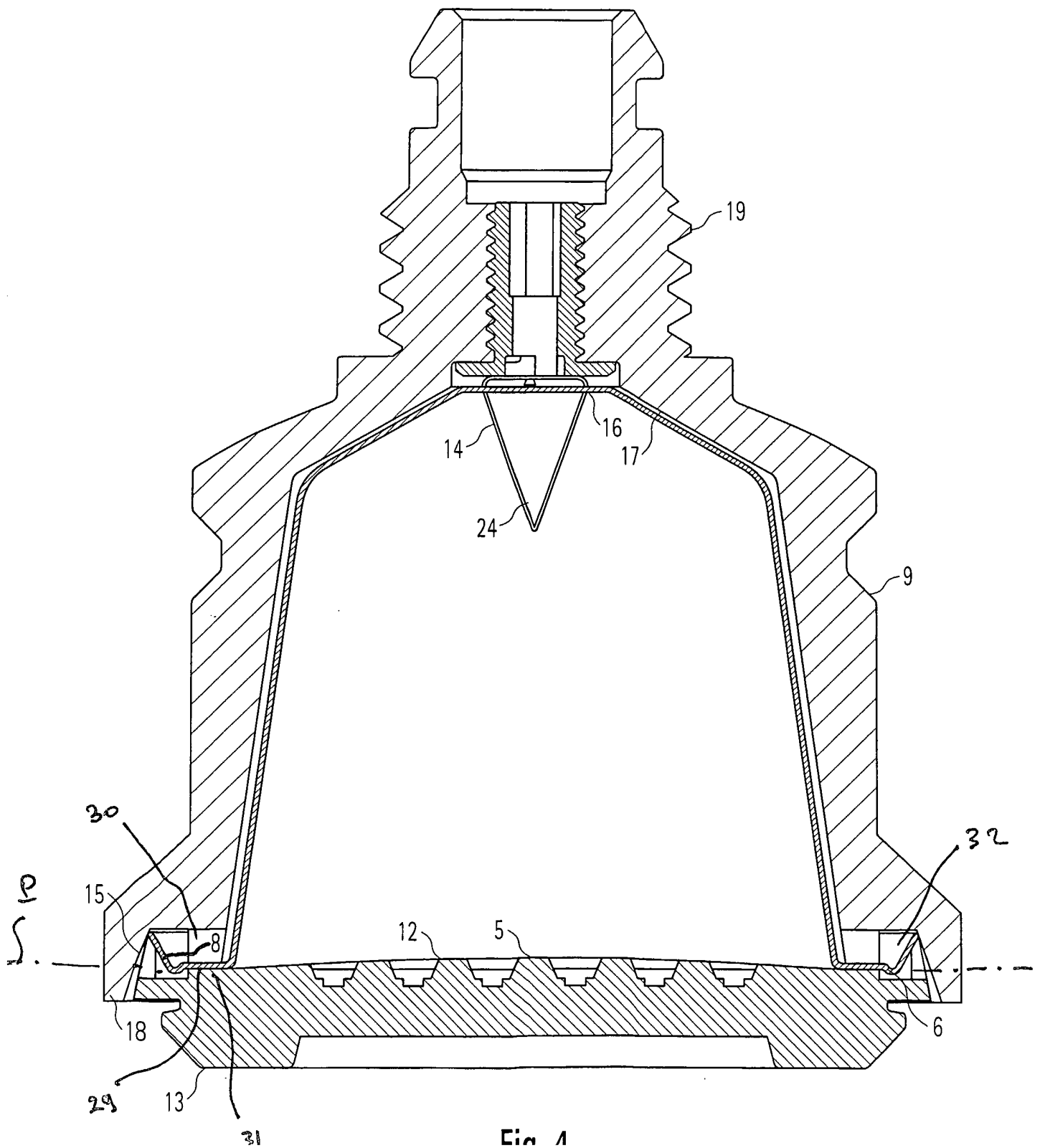

Fig. 3



5/14

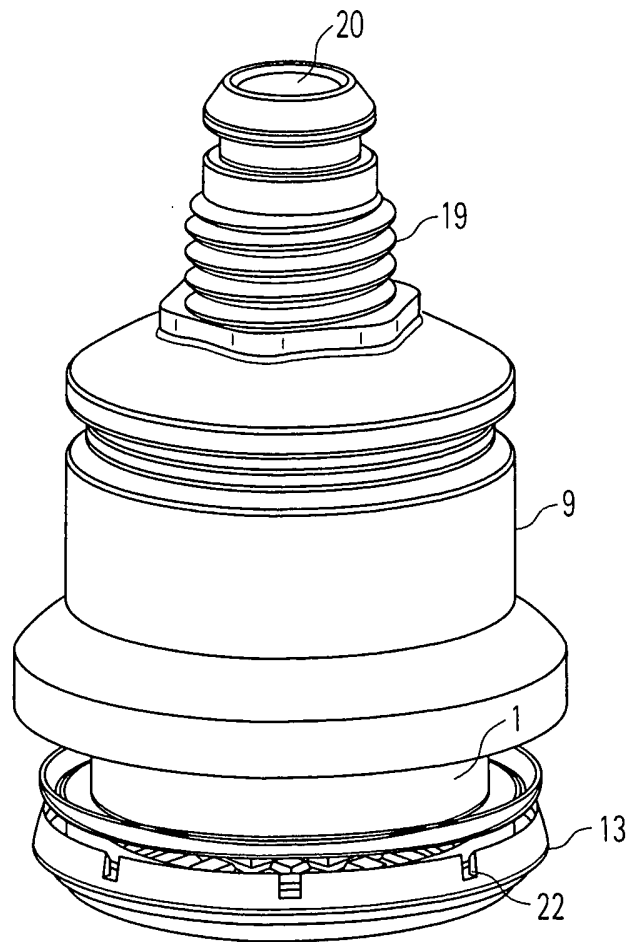

Fig. 5

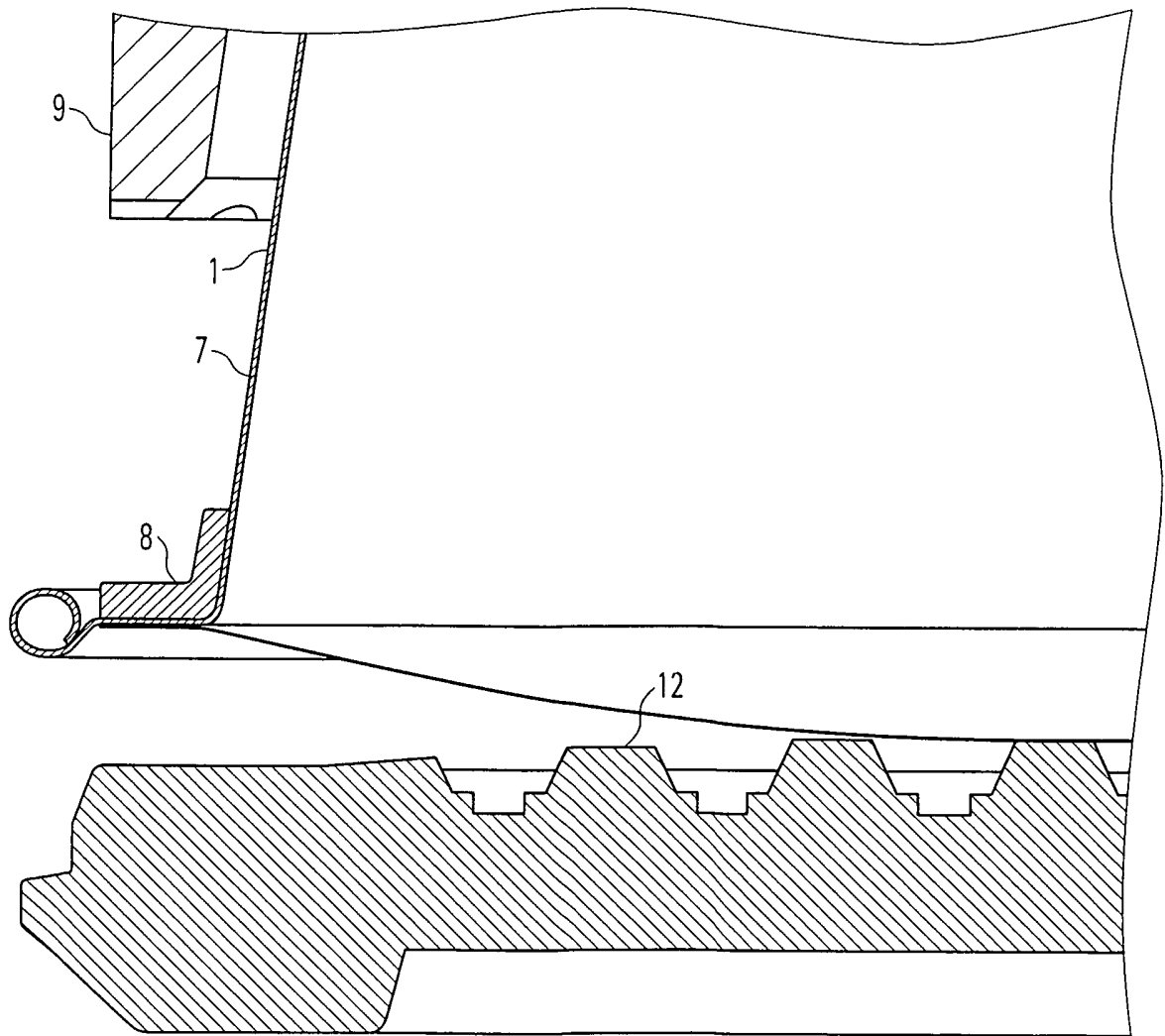

Fig. 7

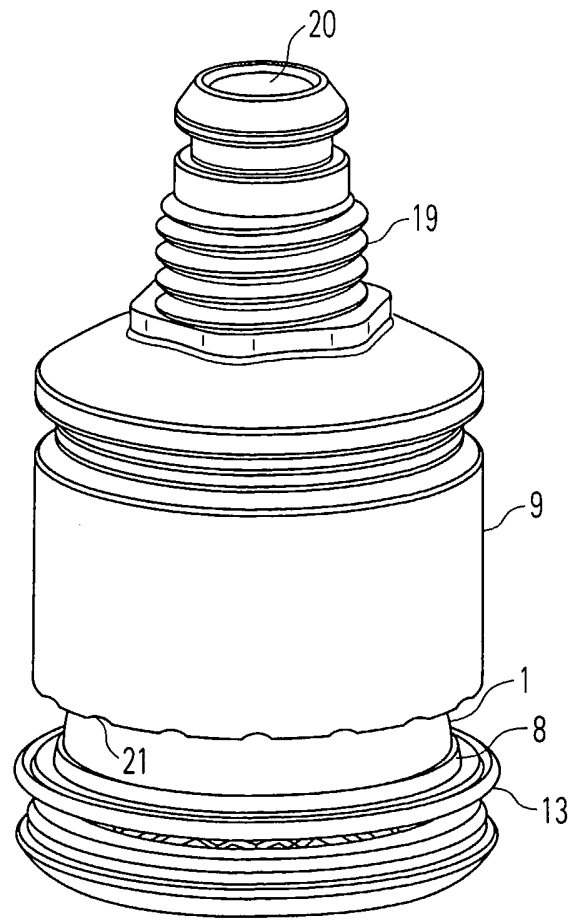

Fig. 8

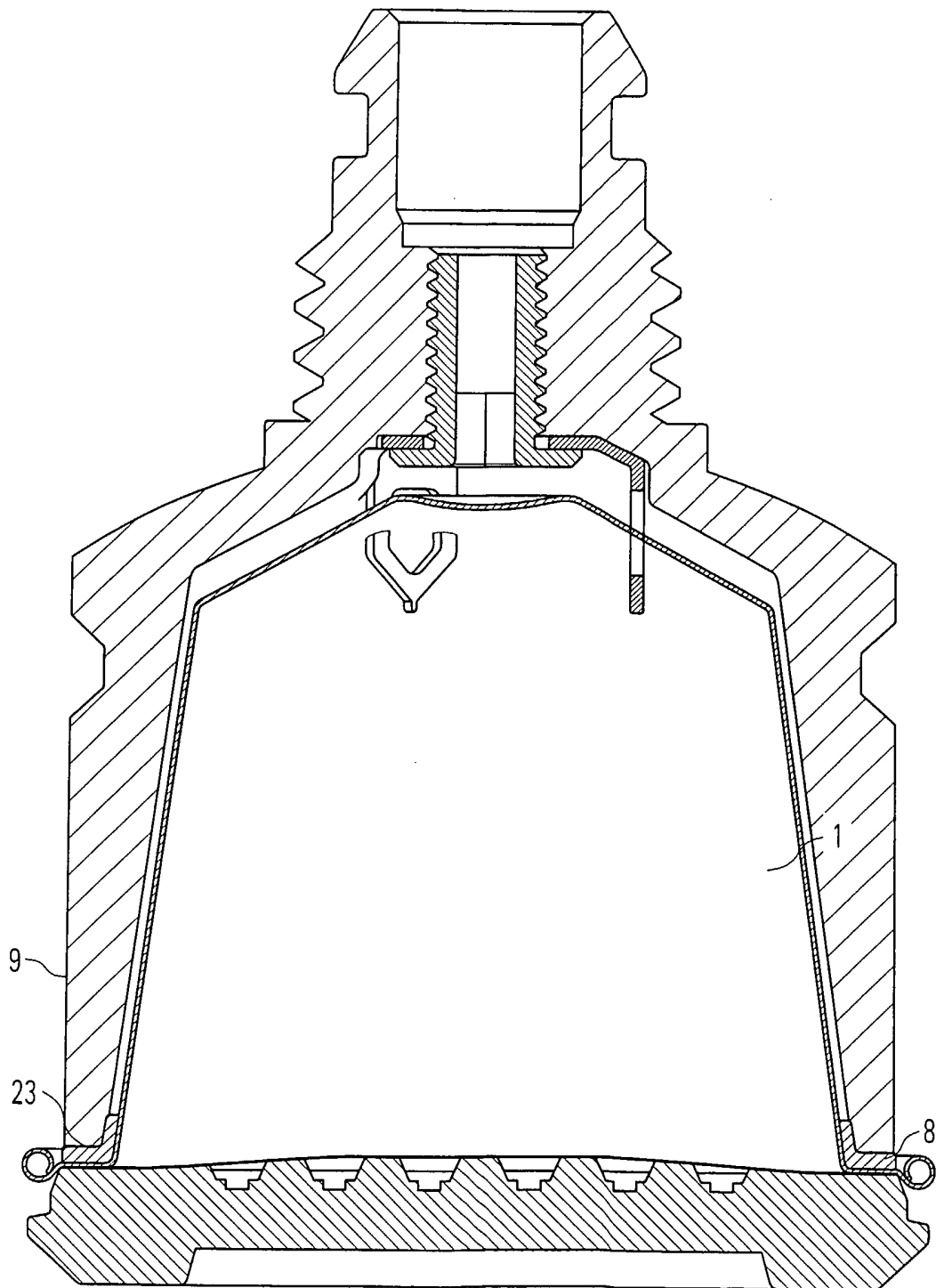

Fig. 9

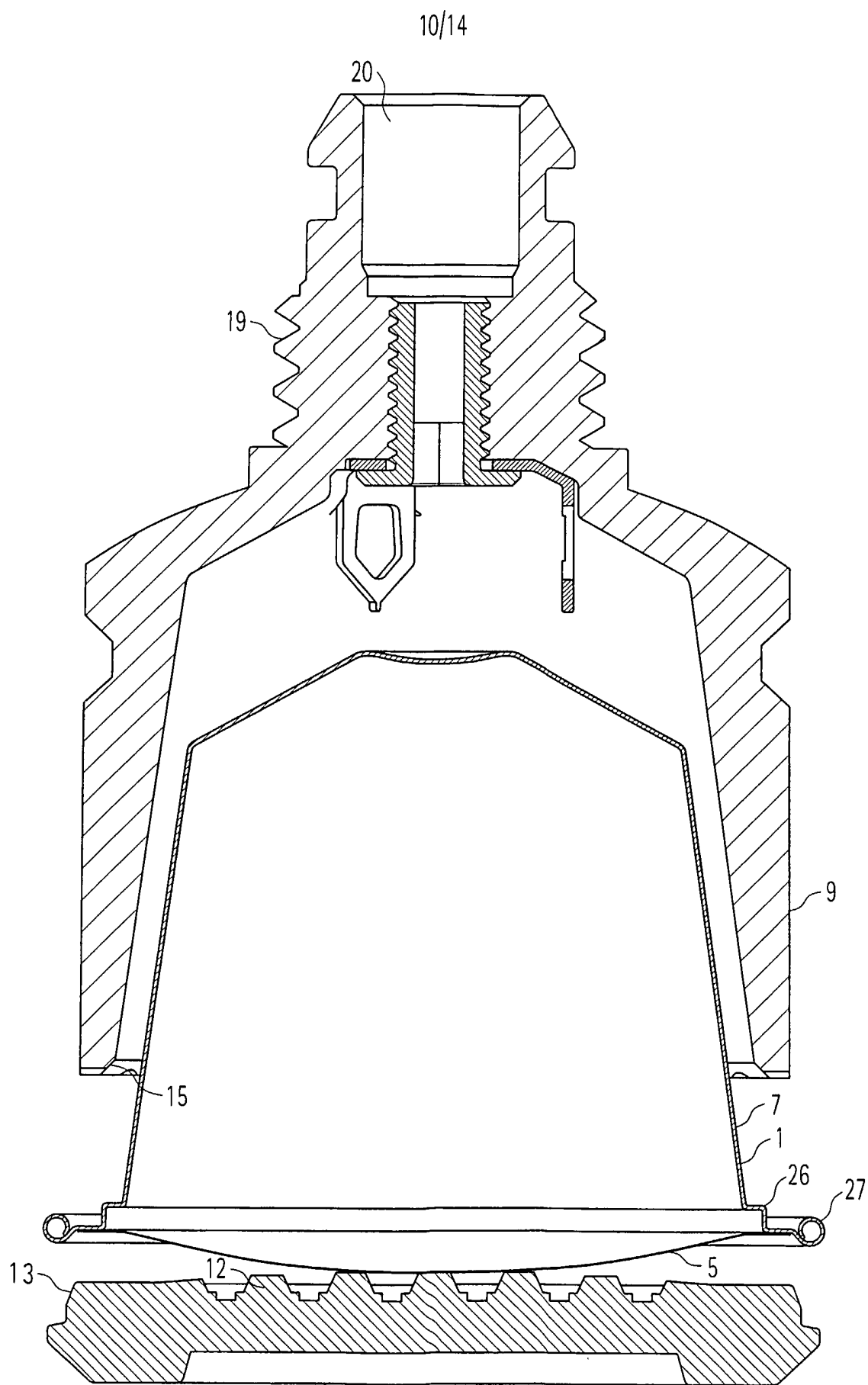

Fig. 10

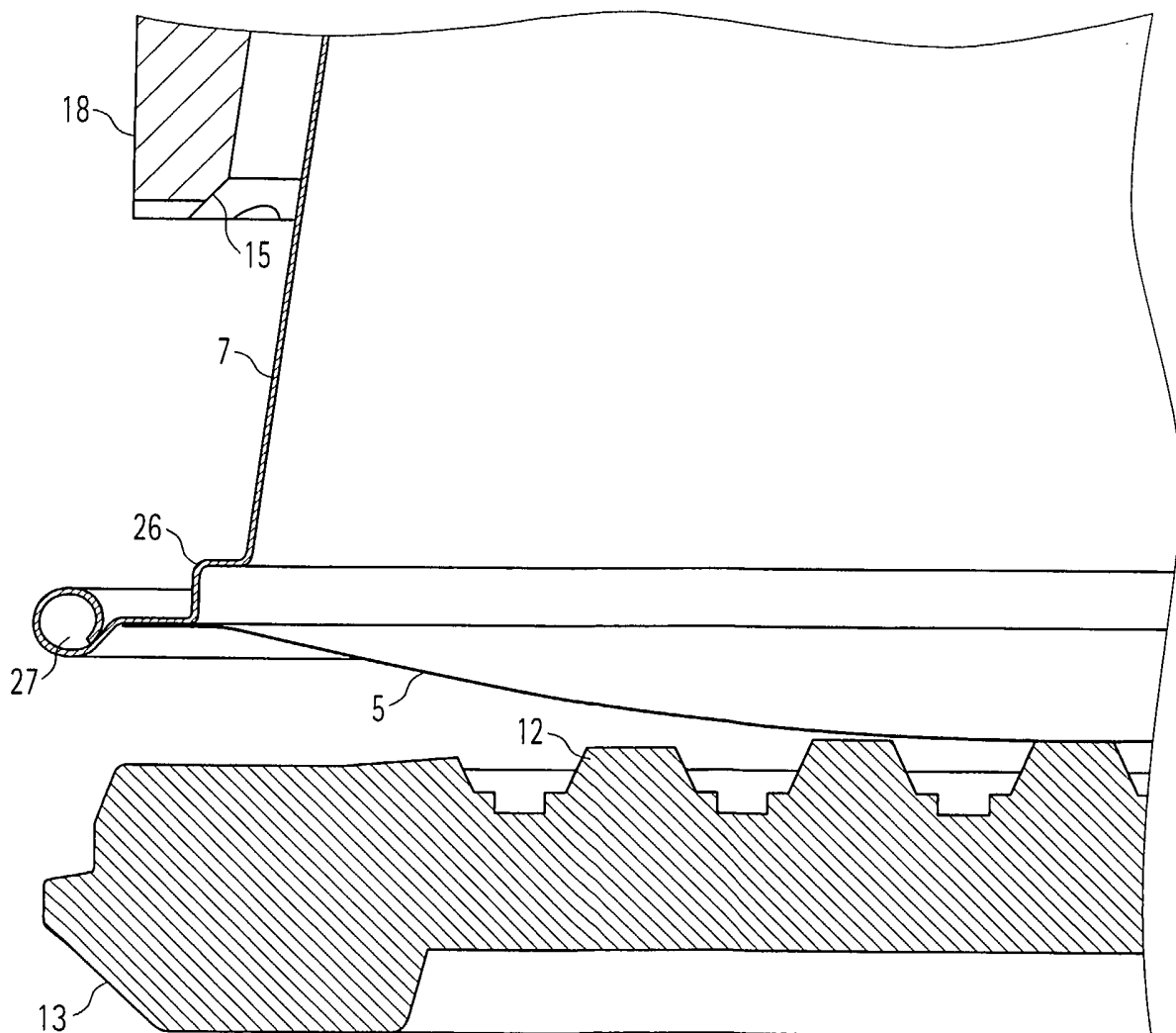

Fig. 11

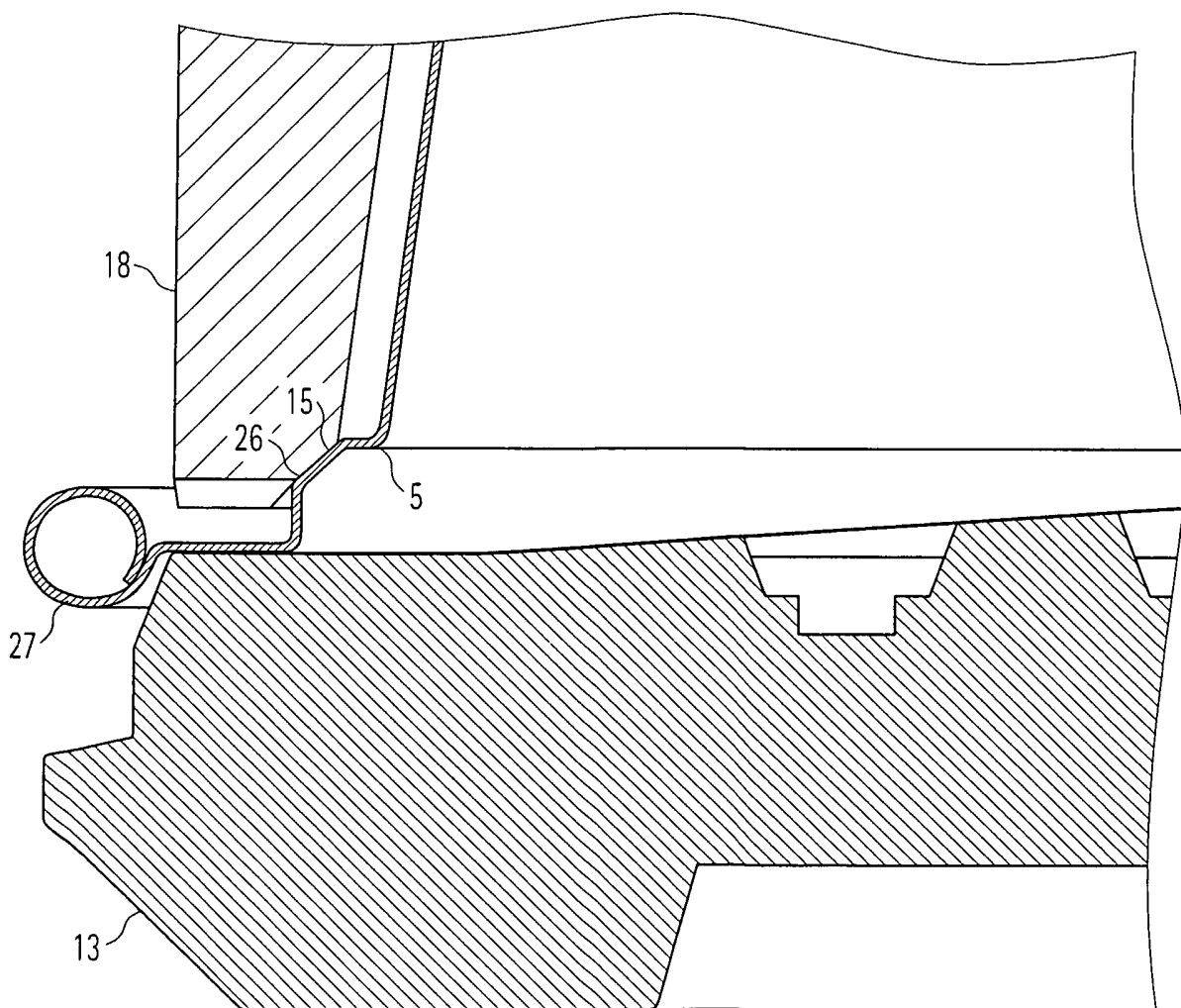

Fig. 12

13/14

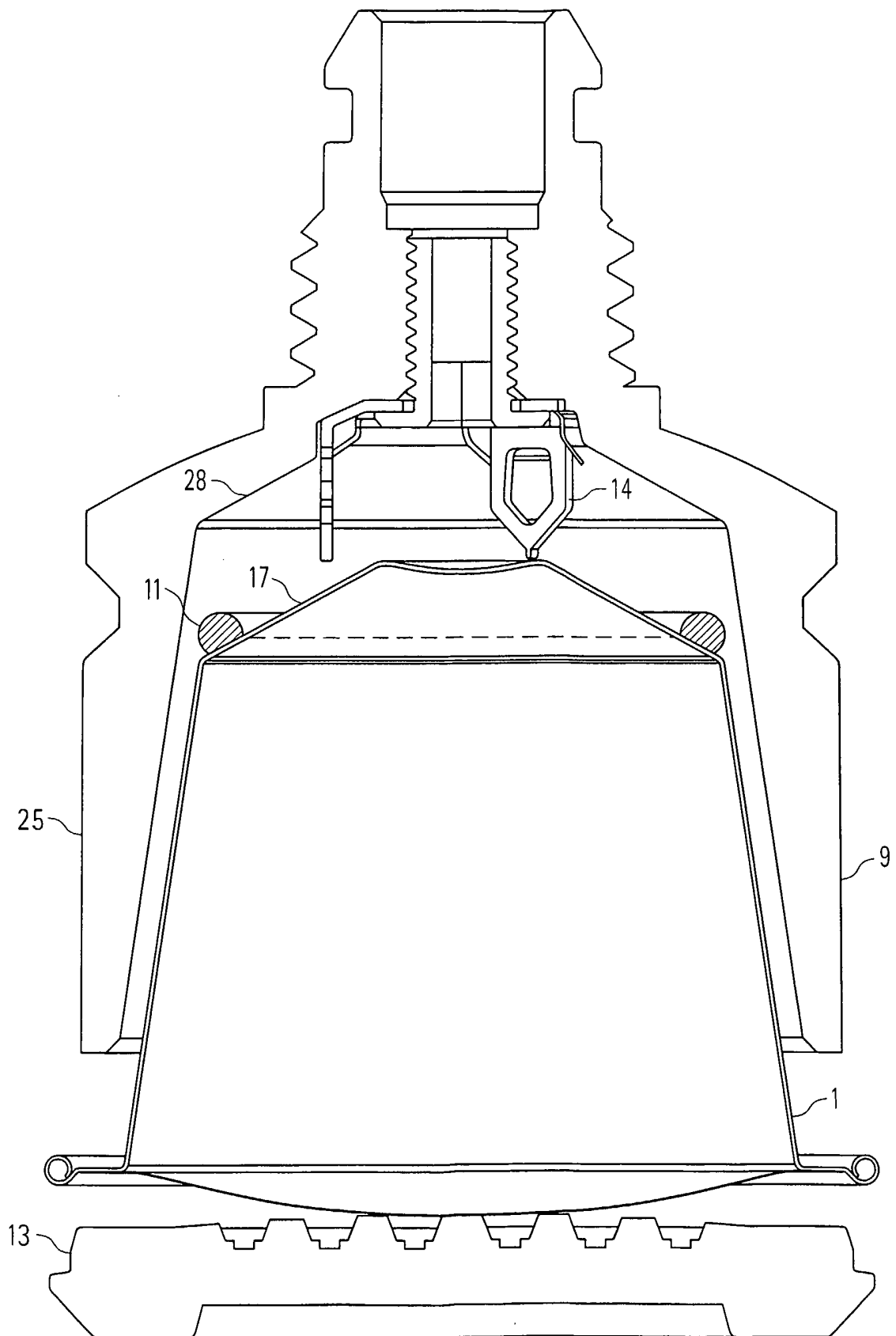

Fig. 13

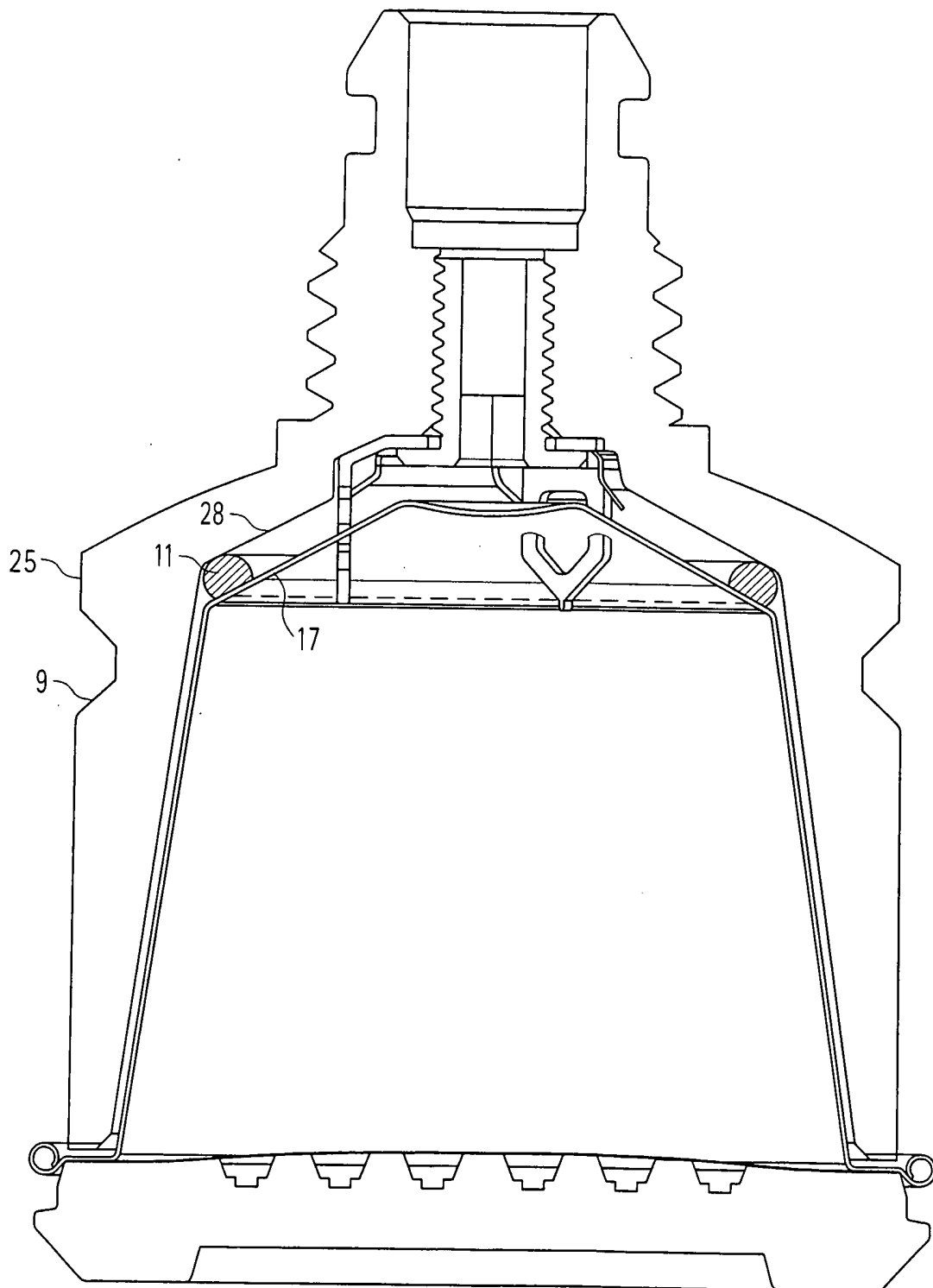

Fig. 14

INTERNATIONAL SEARCH REPORT

International Application No
PCT/EP2005/011306

A. CLASSIFICATION OF SUBJECT MATTER A47J31/40 B65D81/00				
According to International Patent Classification (IPC) or to both national classification and IPC				
B. FIELDS SEARCHED				
Minimum documentation searched (classification system followed by classification symbols) A47J B65D				
Documentation searched other than minimum documentation to the extent that such documents are included in the fields searched				
Electronic data base consulted during the international search (name of data base and, where practical, search terms used) EPO-Internal				
C. DOCUMENTS CONSIDERED TO BE RELEVANT				
Category °	Citation of document, with indication, where appropriate, of the relevant passages	Relevant to claim No.		
X	US 3 445 237 A (LESTER GIDGE) 20 May 1969 (1969-05-20) column 5, lines 21-31; figure 2 -----	1,4,6, 11-17, 20-28		
X	FR 2 617 389 A (DESALTERA) 6 January 1989 (1989-01-06) page 4, line 30 - page 8, line 34; claims 1-4; figures 1,3 -----	1-3, 11-17, 22-28		
X	EP 0 361 569 A ("SAS") 4 April 1990 (1990-04-04) column 3, lines 38-45; figures 1,2 ----- -/--	1,4, 11-16, 21-28		
<input checked="" type="checkbox"/> Further documents are listed in the continuation of box C.				
<input checked="" type="checkbox"/> Patent family members are listed in annex.				
° Special categories of cited documents :				
<table style="width: 100%; border: none;"> <tr> <td style="width: 50%; vertical-align: top;"> *A* document defining the general state of the art which is not considered to be of particular relevance *E* earlier document but published on or after the international filing date *L* document which may throw doubts on priority claim(s) or which is cited to establish the publication date of another citation or other special reason (as specified) *O* document referring to an oral disclosure, use, exhibition or other means *P* document published prior to the international filing date but later than the priority date claimed </td> <td style="width: 50%; vertical-align: top;"> *T* later document published after the international filing date or priority date and not in conflict with the application but cited to understand the principle or theory underlying the invention *X* document of particular relevance; the claimed invention cannot be considered novel or cannot be considered to involve an inventive step when the document is taken alone *Y* document of particular relevance; the claimed invention cannot be considered to involve an inventive step when the document is combined with one or more other such documents, such combination being obvious to a person skilled in the art. *&* document member of the same patent family </td> </tr> </table>			*A* document defining the general state of the art which is not considered to be of particular relevance *E* earlier document but published on or after the international filing date *L* document which may throw doubts on priority claim(s) or which is cited to establish the publication date of another citation or other special reason (as specified) *O* document referring to an oral disclosure, use, exhibition or other means *P* document published prior to the international filing date but later than the priority date claimed	*T* later document published after the international filing date or priority date and not in conflict with the application but cited to understand the principle or theory underlying the invention *X* document of particular relevance; the claimed invention cannot be considered novel or cannot be considered to involve an inventive step when the document is taken alone *Y* document of particular relevance; the claimed invention cannot be considered to involve an inventive step when the document is combined with one or more other such documents, such combination being obvious to a person skilled in the art. *&* document member of the same patent family
A document defining the general state of the art which is not considered to be of particular relevance *E* earlier document but published on or after the international filing date *L* document which may throw doubts on priority claim(s) or which is cited to establish the publication date of another citation or other special reason (as specified) *O* document referring to an oral disclosure, use, exhibition or other means *P* document published prior to the international filing date but later than the priority date claimed	*T* later document published after the international filing date or priority date and not in conflict with the application but cited to understand the principle or theory underlying the invention *X* document of particular relevance; the claimed invention cannot be considered novel or cannot be considered to involve an inventive step when the document is taken alone *Y* document of particular relevance; the claimed invention cannot be considered to involve an inventive step when the document is combined with one or more other such documents, such combination being obvious to a person skilled in the art. *&* document member of the same patent family			
Date of the actual completion of the international search <p style="text-align: center; font-size: large;">13 December 2005</p>		Date of mailing of the international search report <p style="text-align: center; font-size: large;">23/12/2005</p>		
Name and mailing address of the ISA European Patent Office, P.B. 5818 Patentlaan 2 NL - 2280 HV Rijswijk Tel. (+31-70) 340-2040, Tx. 31 651 epo nl, Fax: (+31-70) 340-3016		Authorized officer <p style="text-align: center; font-size: large;">Cazacu, C</p>		

INTERNATIONAL SEARCH REPORT

International Application No
PCT/EP2005/011306

C.(Continuation) DOCUMENTS CONSIDERED TO BE RELEVANT		
Category °	Citation of document, with indication, where appropriate, of the relevant passages	Relevant to claim No.
A	FR 2 160 634 A (MARLET BARRERA JOSE; MARLET BARRERA JOSE,ES) 29 June 1973 (1973-06-29) cited in the application -----	1-28
A	EP 0 512 470 A (SOCIETE DES PRODUITS NESTLE S.A) 11 November 1992 (1992-11-11) cited in the application column 13, line 32 - column 14, line 41; figures 1,3-6 -----	1-28

INTERNATIONAL SEARCH REPORT

Information on patent family members

International Application No
PCT/EP2005/011306

Patent document cited in search report	A	Publication date	Patent family member(s)	Publication date
US 3445237	A	20-05-1969	NONE	
FR 2617389	A	06-01-1989	NONE	
EP 0361569	A	04-04-1990	BE 1002512 A6	05-03-1991
FR 2160634	A	29-06-1973	AU 5122073 A	18-07-1974
			BE 791540 A1	16-03-1973
			DE 2255552 A1	24-05-1973
			IT 973613 B	10-06-1974
			JP 48063875 A	05-09-1973
			NL 7215171 A	22-05-1973
EP 0512470	A	11-11-1992	NONE	

INTERNATIONAL SEARCH REPORT

International application No.
PCT/EP2005/011306

Box II Observations where certain claims were found unsearchable (Continuation of item 2 of first sheet)

This International Search Report has not been established in respect of certain claims under Article 17(2)(a) for the following reasons:

1. Claims Nos.:
because they relate to subject matter not required to be searched by this Authority, namely:

2. Claims Nos.: 29
because they relate to parts of the International Application that do not comply with the prescribed requirements to such an extent that no meaningful International Search can be carried out, specifically:
see FURTHER INFORMATION sheet PCT/ISA/210

3. Claims Nos.:
because they are dependent claims and are not drafted in accordance with the second and third sentences of Rule 6.4(a).

Box III Observations where unity of invention is lacking (Continuation of item 3 of first sheet)

This International Searching Authority found multiple inventions in this international application, as follows:

1. As all required additional search fees were timely paid by the applicant, this International Search Report covers all searchable claims.

2. As all searchable claims could be searched without effort justifying an additional fee, this Authority did not invite payment of any additional fee.

3. As only some of the required additional search fees were timely paid by the applicant, this International Search Report covers only those claims for which fees were paid, specifically claims Nos.:

4. No required additional search fees were timely paid by the applicant. Consequently, this International Search Report is restricted to the invention first mentioned in the claims; it is covered by claims Nos.:

Remark on Protest

- The additional search fees were accompanied by the applicant's protest.
- No protest accompanied the payment of additional search fees.

FURTHER INFORMATION CONTINUED FROM PCT/ISA/ 210

Continuation of Box II.2

Claims Nos.: 29

The beverage of claim 29 does not include any intrinsic features but merely a reference to a method which does not make clear which are the new and inventive features of the beverage made according to the method of claims 27 or 28 in respect of the beverages of the prior art as disclosed in the documents cited in the Search Report.

The applicant's attention is drawn to the fact that claims relating to inventions in respect of which no international search report has been established need not be the subject of an international preliminary examination (Rule 66.1(e) PCT). The applicant is advised that the EPO policy when acting as an International Preliminary Examining Authority is normally not to carry out a preliminary examination on matter which has not been searched. This is the case irrespective of whether or not the claims are amended following receipt of the search report or during any Chapter II procedure. If the application proceeds into the regional phase before the EPO, the applicant is reminded that a search may be carried out during examination before the EPO (see EPO Guideline C-VI, 8.5), should the problems which led to the Article 17(2) declaration be overcome.