

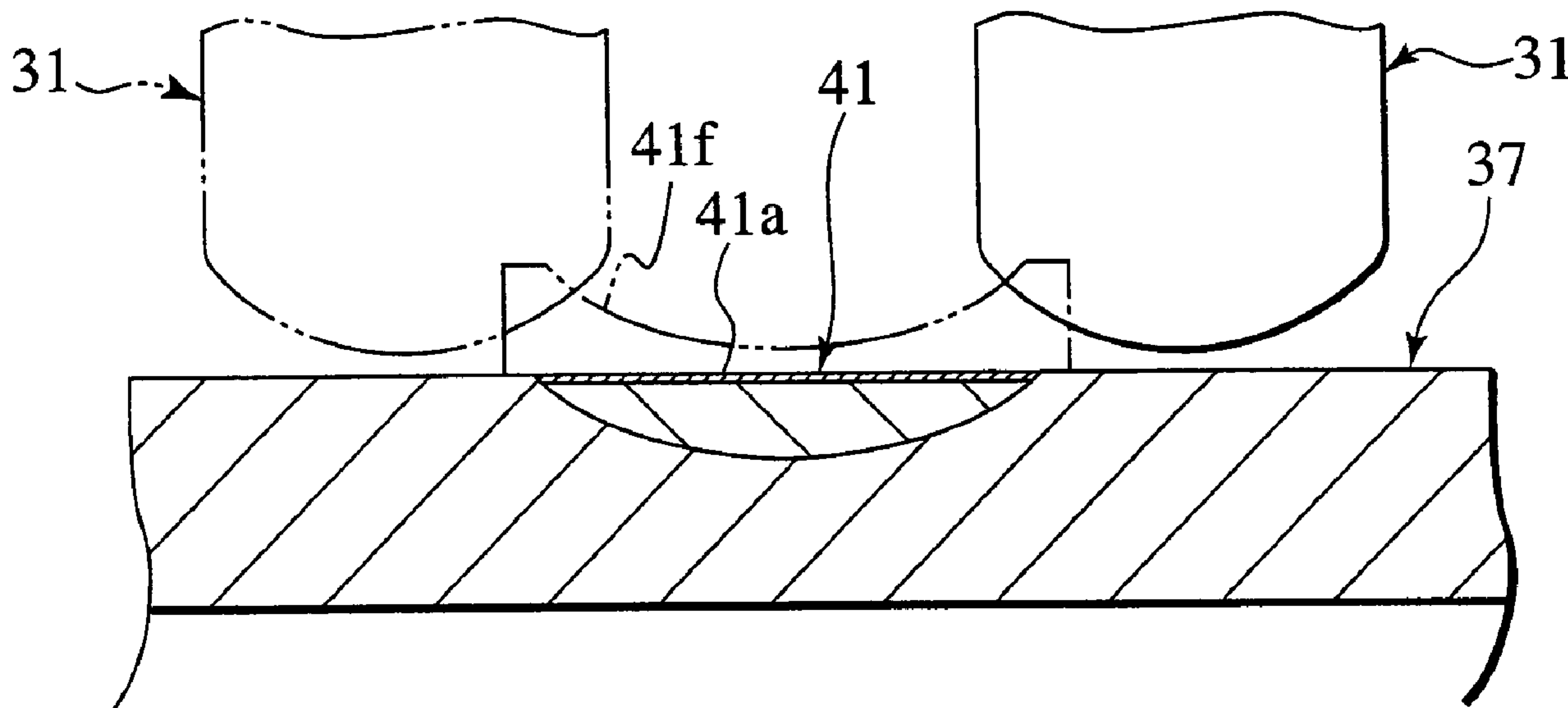

(86) Date de dépôt PCT/PCT Filing Date: 2004/06/11
 (87) Date publication PCT/PCT Publication Date: 2004/12/23
 (45) Date de délivrance/Issue Date: 2012/02/07
 (85) Entrée phase nationale/National Entry: 2005/12/09
 (86) N° demande PCT/PCT Application No.: JP 2004/008212
 (87) N° publication PCT/PCT Publication No.: 2004/111303
 (30) Priorités/Priorities: 2003/06/11 (JP2003-167074);
 2003/06/11 (JP2003-167025)

(51) Cl.Int./Int.Cl. *C23C 26/00* (2006.01),
B22D 29/00 (2006.01), *B23H 5/00* (2006.01),
C21D 9/50 (2006.01)
 (72) Inventeurs/Inventors:
 OCHIAI, HIROYUKI, JP;
 WATANABE, MITSUTOSHI, JP;
 URABE, TATSUTO, JP;
 GOTO, AKIHIRO, JP;
 AKIYOSHI, MASAO, JP
 (73) Propriétaires/Owners:
 MITSUBISHI DENKI KABUSHIKI KAISHA, JP;
 IHI CORPORATION, JP
 (74) Agent: GOWLING LAFLEUR HENDERSON LLP

(54) Titre : PROCEDE DE FABRICATION D'UN PRODUIT METALLIQUE, PRODUIT METALLIQUE, PROCEDE DE
 CONNEXION DE COMPOSANT METALLIQUE ET STRUCTURE DE CONNEXION
 (54) Title: PRODUCTION METHOD OF METAL PRODUCT, METAL PRODUCT, CONNECTION METHOD OF METAL
 COMPONENT AND CONNECTION STRUCTURE



(57) **Abrégé/Abstract:**

A deposition is gradually formed by molding a product main body, removing a defect periphery including a defect generated on a surface to be treated of the product main body by molding so that a recess portion is formed on the surface to be treated of the product main body, employing a molded electrode composed of a molded body molded from a powder of a metal or the molded body processed with a heat treatment, and generating a pulsing electric discharge between the recess portion periphery including the recess portion and the molded electrode in an electrically insulating liquid or gas so that a material of the molded electrode or a reaction substance of the material carries out deposition and such at the recess portion periphery by energy of the electric discharge.

ABSTRACT

A deposition is gradually formed by molding a product main body, removing a defect periphery including a defect generated on a surface to be treated of the product main body by molding so that a recess portion is formed on the surface to be treated of the product main body, employing a molded electrode composed of a molded body molded from a powder of a metal or the molded body processed with a heat treatment, and generating a pulsing electric discharge between the recess portion periphery including the recess portion and the molded electrode in an electrically insulating liquid or gas so that a material of the molded electrode or a reaction substance of the material carries out deposition and such at the recess portion periphery by energy of the electric discharge.

DESCRIPTION

PRODUCTION METHOD OF METAL PRODUCT, METAL PRODUCT, CONNECTION
METHOD OF METAL COMPONENT AND CONNECTION STRUCTURE

5

TECHNICAL FIELD

The present invention relates to a production method of a metal product, a metal product, a connection method of metal components and a connection structure.

10

BACKGROUND ART

A series of steps for producing a metal product such as a cylinder and a series of steps for joining a pair of metal components respectively having beveling portions respectively include a step
15 of forming a weld deposition.

More specifically, in a case of producing the metal product, first, a product main body is molded by means of casting for example. Then, a defect caused by molding is generated on a surface to be treated of the product main body. Next, a peripheral portion of
20 the defect including the defect is removed by grinding so that a recess portion is formed on the portion to be treated of the product main body. Further, a weld deposition is formed at a recess portion periphery including the recess portion by means of welding.

Moreover, in a case of joining the pair of the metal components,
25 first, a recess portion is defined by a beveling portion of one of the metal components and another beveling portion of the other of the metal components by means of butting the pair of the metal components. Then, a weld deposition is formed at a recess portion periphery including the recess portion by means of welding.

30

DISCLOSURE OF INVENTION

In the meantime, because the weld deposition is formed by means of welding, in other words, because the weld deposition in an elevated temperature state is in an instant or in a short time
35 formed at the recess portion periphery, the temperature of the recess portion periphery drastically increases. Thereby, thermal deformation at the recess portion periphery becomes great and there

are problems that it gives rise to poor quality in production of the metal product or poor quality in joining of the pair of the metal components.

5 In one aspect the invention provides a method for production of a metal product, comprising steps of: molding a main body of a metal; removing a portion defining a defect included in the main body to form a recess portion; depositing a deposition from a deposition tool electrode to fill the
10 recess portion by processing the main body as a workpiece of an electric spark machine opposed to the deposition tool electrode.

 A further aspect of the present invention is a method for joining metal components, comprising steps of: butting the
15 metal components respectively having beveled ends to define a recess portion between the beveled ends; depositing a deposition from a deposition tool electrode to fill the recess portion by processing the metal components as a workpiece of an electric spark machine opposed to the deposition tool
20 electrode.

 Another aspect of the invention provides a joint structure comprising: a pair of components of a metal respectively including beveling ends, the beveling ends being butted with each other to form a recess portion defined by the
25 beveling ends; a deposition deposited from a deposition tool electrode by processing the components as a workpiece of an electric spark machine opposed to the deposition tool electrode to fill the recess portion.

BRIEF DESCRIPTION OF DRAWINGS

- [Fig. 1] A drawing showing an electric spark machine in accordance with a first embodiment.
- [Fig. 2] A partial cross sectional view of a cylinder in
5 accordance with the first embodiment.
- [Fig. 3] A drawing explaining a production method of a metal product in accordance with the first embodiment.
- [Fig. 4] A drawing explaining a production method of a metal product in accordance with the first embodiment.
- 10 [Fig. 5] A drawing explaining a production method of a metal product in accordance with the first embodiment.
- [Fig. 6] A drawing explaining a production method of a metal product in accordance with the first embodiment.
- [Fig. 7] A drawing explaining a production method of a metal
15 product in accordance with the first embodiment.
- [Fig. 8] A partial cross sectional view of a cylinder in accordance with a second embodiment.
- [Fig. 9] A drawing explaining a production method of a metal product in accordance with the second embodiment.
- 20 [Fig. 10] A drawing explaining a production method of a metal product in accordance with the second embodiment.
- [Fig. 11] A drawing explaining a production method of a metal product in accordance with the second embodiment.
- [Fig. 12] A drawing explaining a production method of a metal
25 product in accordance with the second embodiment.
- [Fig. 13] A drawing explaining a production method of a metal product in accordance with the second embodiment.
- [Fig. 14] A partial cross sectional view of a cylinder in accordance with a third embodiment.
- 30 [Fig. 15] A drawing explaining a production method of a metal product in accordance with the third embodiment.
- [Fig. 16] A drawing explaining a production method of a metal product in accordance with the third embodiment.
- [Fig. 17] A drawing explaining a production method of a metal
35 product in accordance with the third embodiment.
- [Fig. 18] A partial cross sectional view of a joint structure in accordance with a fourth embodiment.

[Fig. 19] A drawing explaining a joining method of a metal product in accordance with the fourth embodiment.

[Fig. 20] A drawing explaining a joining method of a metal product in accordance with the fourth embodiment.

5 [Fig. 21] A drawing explaining a joining method of a metal product in accordance with the fourth embodiment.

BEST MODE FOR CARRYING OUT THE INVENTION

A description will be hereinafter given to certain
10 embodiments of the present invention for describing the present invention in further detail with appropriate reference to the accompanying drawings. Meanwhile, in the description, in proper, "a cross direction" is referred to as an X-axis direction, "a horizontal direction" is referred to as a Y-axis direction and
15 "a vertical direction" is referred to as a Z-axis direction.

(FIRST EMBODIMENT)

An electric spark machine 1 applied to a production method of a metal product in accordance with a first embodiment of the present invention will be described hereinafter with reference
20 to Fig. 1.

The electric spark machine 1 is provided with a bed 3 extending in an X-axis direction and a Y-axis direction and a column 5 extending in an Z-axis. Further, the bed 3 is provided with a table 7 and the table 7 is movable in the X-axis direction by means of a drive
25 of an X-axis servo-motor and movable in the Y-axis direction by means of a drive of a Y-axis servo-motor.

The table 7 is provided with a processing tank 13 for reserving an electrically insulating liquid S such as oil and, in the processing tank 13, a support plate 15 is provided. The support
30 plate 15 is provided with a jig 17 to which a metal product or such described later is capable of being set. Meanwhile, the jig 17 is electrically connected to an electric power source 19 via the support plate 15 and a concrete constitution of the jig 17 is changeable depending on the metal product and such.

35 The column 5 is provided with a processing head 21 and the processing head 21 is movable in a Z-axis direction by means of a drive of a Z-axis servo-motor. Here, when the table 7 is moved

in the X-axis direction by means of the drive of the X-axis servo-motor, the processing head 21 is capable of moving in the X-axis direction relative to the table 7. Moreover, when the table 7 is moved in the Y-axis direction by means of the drive of the Y-axis servo-motor, the processing head 21 is capable of moving in the Y-axis direction relative to the table 7.

Further, the processing head 21 is provided with a first holder 29 for supporting a molded electrode 25 or a molded electrode 27 and, in the vicinity of the first holder 29 in the processing head 21, a second holder 33 for supporting a hard electrode 31 having exhaustion resistance is provided. The first holder 29 and the second holder 33 are electrically connected to the electric power source 19. Moreover, concrete constitutions of the molded electrodes 25, 27 will be described later.

Next, a cylinder 35 as a metal component which is a subject of the production method of the metal product in accordance with the first embodiment will be described hereinafter with reference to Fig. 2.

The cylinder 35 as the metal component in accordance with the first embodiment is one of constituent elements of a gas turbine and provided with a cylinder main body 37 as a product main body. Further, at an outer peripheral surface of the cylinder main body 37, a recess portion 39 is formed by means of energy of an electric discharge and, at a recess portion periphery 39' including the recess portion 39, a deposition 41 is formed by means of energy of an electric discharge. Meanwhile, details of the recess portion 39 and the deposition 41 will be described later.

Next, the production method of the metal product in accordance with the first embodiment will be described hereinafter with reference to from Fig. 1 to Fig. 7.

The production method of the metal product in accordance with the first embodiment is a method for producing the cylinder 35 as the metal component and employs the electric spark machine 1, the molded electrode 25, the hard electrode 31 and a heat treatment furnace 43 shown in Fig. 7.

Here, the molded electrode 25 is a molded body molded from powder of a material having the same composition as a base material

of the cylinder main body 37, powder of a material having a similar composition to the base material of the cylinder main body 37, or powder of a material having a coefficient of thermal expansion close to a coefficient of thermal expansion of the base material
5 of the cylinder main body 37 by means of compression by pressing; or the molded body subject to a heat treatment by a vacuum furnace or such.

Meanwhile, in a case where the base material of the cylinder 37 is, for example, an alloy of AMS (Aerospace Material
10 Specifications) No. 5662, various nickel alloys become the material having the similar composition and cobalt or cobalt alloys become the material having the coefficient of the thermal expansion close thereto. Meanwhile, instead of molding by compressing, the electrode 25 may be formed by slurry pouring, MIM (Metal Injection
15 Molding), spray forming and such.

Moreover, the hard electrode 31 is composed of a solid substance of graphite, tungsten alloys, or copper alloys.

Further, the production method of the metal product in accordance with the first embodiment is provided with a (1-1)
20 molding step, a (1-2) defect removal step, a (1-3) deposition step, a (1-4) excessive deposition removal step and a (1-5) heat treatment step.

(1-1) MOLDING STEP

The cylinder main body 37 as the product main body is molded
25 by means of casting by using a not-shown casting mold. Meanwhile, as shown in Fig. 3, casting cavities D caused by molding, as a type of defects, are generated on a peripheral surface of the cylinder main body 37 as a surface to be treated.

(1-2) DEFECT REMOVAL STEP

30 After finishing the (1-1) molding step, the cylinder main body 37 is set to the jig 17. Next, by means of driving the X-axis servo-motor 9 and the Y-axis servo-motor 11, the table 7 is moved in the X-axis direction and the Y-axis direction to position the cylinder main body 37 so that a casting cavity periphery D' as
35 a defect periphery including the casting cavities D is opposed to the hard electrode 31. Meanwhile, there may be a case where the table 7 is only necessary to be moved in any of the X-axis

direction and the Y-axis direction.

Further, a pulsing electric discharge is generated between the casting cavity periphery D' and the hard electrode 31. Thereby, as shown in Fig. 4, by means of energy of the electric discharge, the casting cavities D are removed and a recess portion 39 can be formed on the peripheral surface of the cylinder main body 37. Meanwhile, when generating the pulsing discharge, the electrode, as being integral with the processing head 21, is reciprocated in the Z-axis direction by a small travel distance by means of a drive of the Z-axis servo-motor 23.

(1-3) DEPOSITION STEP

After finishing the (1-2) defect removal step, by means of driving the X-axis servo-motor 9 and the Y-axis servo-motor 11, the table 7 is moved in the X-axis direction and the Y-axis direction to position the cylinder main body 37 so that a recess portion periphery 39' is opposed to the molded electrode 25. Meanwhile, there may be a case where the table 7 is only necessary to be moved in any of the X-axis direction and the Y-axis direction.

Further, a pulsing electric discharge is generated between the recess portion periphery 39' and the molded electrode 25 in an electrically insulating liquid S. Thereby, as shown in Fig. 5, by means of energy of the electric discharge, a material of the molded electrode 25 or a reaction substance of the material carries out deposition, diffusion and/or welding at the recess portion periphery 39' and thereby a deposition 41 can be gradually formed at the recess portion periphery 39'. Meanwhile, when generating the pulsing discharge, the molded electrode 25, as being integral with the processing head 21, is reciprocated in the Z-axis direction by a small travel distance by means of a drive of the Z-axis servo-motor 23.

Meanwhile, "deposition, diffusion and/or welding" means all meanings including "desposition", "diffusion", "welding", "mixed phenomena of deposition and diffusion", "mixed phenomena of deposition and welding", "mixed phenomena of diffusion and welding" and "mixed phenomena of deposition, diffusion and welding".

Here, dimensions of the deposition 41 are made to be greater than dimensions of the recess portion 39. In concrete terms, an

outer periphery of the deposition 41 is made to spread outward in 0.5mm or more relative to an outer periphery of the recess portion 39 and a thickness of the deposition 41 is made to be thicker in 0.3mm or more than a thickness required to filling the recess portion 39. Thereby diffusion bonding among particles at the interior of the deposition 41 can be generated.

Meanwhile, a part of the deposition 41 becomes an excessive deposition 41f sticking out of the recess portion 39.

(1-4) EXCESSIVE DEPOSITION REMOVAL STEP

After finishing the (1-3) deposition step, by means of driving the X-axis servo-motor 9 and the Y-axis servo-motor 11, the table 7 is moved in the X-axis direction and the Y-axis direction to position the cylinder main body 37 so that the deposition 41 is opposed to the hard electrode 31. Meanwhile, there may be a case where the table 7 is only necessary to be moved in any of the X-axis direction and the Y-axis direction.

Further, a pulsing electric discharge is generated between the deposition 41 and the hard electrode 31 in an electrically insulating liquid S. Thereby, as shown in Fig. 6, by means of energy of the electric discharge, a thin film 41a composed of a structure of high density can be generated as well as the excessive deposition 41f can be removed. Meanwhile, when generating the pulsing discharge, the hard electrode 31 is moved in the X-axis direction relative to the cylinder main body 37 and the hard electrode 31, as being integral with the processing head 21, is reciprocated in the Z-axis direction by a small travel distance by means of a drive of the Z-axis servo-motor 23.

(1-5) HEAT TREATMENT STEP

After finishing the (1-4) excessive deposition removal step, the cylinder main body 37 is removed from the jig 17 and set at a predetermined position of the heat treatment furnace 43. Further, as shown in Fig. 7, the deposition 41 accompanying the cylinder main body 37 is kept at a high temperature in a vacuum or in the air by means of the heat treatment furnace 43. Thereby, a heat treatment can be processed with respect to the deposition 41 so as to progress diffusion bonding among the particles at the interior of the deposition 41 and the production of the cylinder 35 as the

metal product is finished.

Here, the temperature and the period of time are 20 minutes at a high temperature of 1050 degrees C and subsequently 4 hours at a high temperature of 760 degrees C in a case where the deposition
5 41 is composed of a nickel alloy or a cobalt alloy.

Meanwhile, the production method of the metal product in accordance with the aforementioned first embodiment may be modified as in the following embodiment.

More specifically, the (1-4) excessive deposition removal
10 step or the (1-5) heat treatment step can be omitted from the series of the steps in the production method of the metal production in accordance with the first embodiment or step orders of the (1-4) excessive deposition removal step and the (1-5) heat treatment step can be interchanged.

Moreover, instead of generating the pulsing discharge in
15 the electrically insulating liquid S, a pulsing discharge may be generated in an electrically insulating gas.

Furthermore, by using a grinding lathe instead of the electric
spark machine 1, the casting cavity periphery D' may be removed
20 or the excessive deposition 41f may be removed.

Moreover, instead of removing the casting cavity periphery
D', any defect periphery including defects such as cracks may be removed.

Next, operations of the first embodiment will be described.

Because energy of the electric discharge locally acts on
25 a prominently small part and the deposition 41 is gradually formed by carrying out deposition, diffusion and/or welding of the material of the molded electrode 25 or such, a temperature of the recess portion periphery 39' in the cylinder main body 37 is prevented
30 from rapidly increasing at a time of producing the cylinder 35.

Moreover, because the deposition 41 is formed by means of the energy of the electric discharge, a boundary part between the deposition 41 and a base material of the cylinder main body 37 has a structure in which a composition ratio grades and hence the
35 deposition 41 can be firmly combined with the cylinder main body 37.

Furthermore, because the diffusion bonding among the

particles at the interior of the deposition 41 progresses, a tensile strength of the deposition 41 can be increased.

Moreover, because the dimensions of the deposition 41 formed at the (1-3) deposition step are made to be greater than the
5 dimensions of the recess portion 39, a porous structure is not left in a surface side of the deposition 41 after the (1-4) deposition step.

In accordance with the first embodiment as described above, because the temperature of the recess portion periphery 39' in
10 the cylinder main body 37 is prevented from rapidly increasing at the time of producing the cylinder 35, thermal deformation of the recess portion periphery 39' is sufficiently suppressed and hence defective production of the cylinder 35 is reduced to be almost none.

Moreover, because the deposition 41 can be firmly combined
15 with the cylinder main body 37, the deposition 41 becomes unsusceptible to peeling off from the base material of the cylinder main body 37 and hence quality of the cylinder 35 can be stabilized.

Furthermore, because the tensile strength of the deposition
20 41 can be increased, a mechanical strength of the recess portion periphery 39' in the cylinder main body 37 can be increased.

Moreover, because the deposition 41 has the thin film 41a composed of the structure of high density, permeation of fluid out of the interior of the cylinder 35 can be suppressed.

25 (SECOND EMBODIMENT)

A cylinder 45 as a metal component which is a subject of a production method of a metal product in accordance with a second embodiment will be briefly described hereinafter with reference to Figs. 8-13.

30 The cylinder 45 as the metal component in accordance with the second embodiment is, as similar to the cylinder 35 in accordance with the first embodiment, provided with a cylinder main body 37 as a product main body and, at an outer peripheral surface of the cylinder main body 37, a recess portion 39 is formed by means of
35 energy of an electric discharge. Further, at a recess portion periphery 39' including the recess portion 39, a deposition group 49 constituted of two layers of depositions 47 is formed by means

of energy of an electric discharge. Meanwhile, details of the deposition group 49 will be described later.

Next, the production method of the metal product in accordance with the second embodiment will be described hereinafter with reference to Fig. 1, Fig. 3, Fig. 4 and from Fig. 9 to Fig. 13.

The production method of the metal product in accordance with the second embodiment is a method for producing the cylinder 45 as the metal component and employs the electric spark machine 1, the molded electrode 25, the hard electrode 31 and the heat treatment furnace 43 as described above.

Further, the production method of the metal product in accordance with the second embodiment is provided with a (2-1) molding step, a (2-2) defect removal step, a first deposition step, a (2-4) thin film step, a (2-5) second deposition step, a (2-6) excessive deposition removal step and a (2-7) heat treatment step.

(2-1) MOLDING STEP

This step is carried out in the same manner as the aforementioned (1-1) molding step. (see Fig. 3)

(2-2) DEFECT REMOVAL STEP

This step is carried out in the same manner as the aforementioned (1-2) defect removal step. (see Fig. 4)

(2-3) FIRST DEPOSITION STEP

After finishing the (2-2) defect removal step, by means of driving the X-axis servo-motor 9 and the Y-axis servo-motor 11, the table 7 is moved in the X-axis direction and the Y-axis direction to position the cylinder main body 37 so that the recess portion periphery 39' is opposed to the molded electrode 25. Meanwhile, there may be a case where the table 7 is only necessary to be moved in any of the X-axis direction and the Y-axis direction.

Further, a pulsing electric discharge is generated between the recess portion periphery 39' and the molded electrode 25 in an electrically insulating liquid S. Thereby, as shown in Fig. 9, by means of energy of the electric discharge, a material of the molded electrode 25 or a reaction substance of the material carries out deposition, diffusion and/or welding at the recess portion periphery 39' and thereby the deposition 47 can be gradually formed at the recess portion periphery 39'. Meanwhile, when

generating the pulsing discharge, the molded electrode 25, as being integral with the processing head 21, is reciprocated in the Z-axis direction by a small travel distance by means of a drive of the Z-axis servo-motor 23.

5 (2-4) THIN FILM STEP

After finishing the (2-3) first deposition step, by means of driving the X-axis servo-motor 9 and the Y-axis servo-motor 11, the table 7 is moved in the X-axis direction and the Y-axis direction to position the cylinder main body 37 so that the deposition 47 is
10 opposed to the hard electrode 31. Meanwhile, there may be a case where the table 7 is only necessary to be moved in any of the X-axis direction and the Y-axis direction.

Further, a pulsing electric discharge is generated between the deposition 47 and the hard electrode 31 in an electrically
15 insulating liquid S. Thereby, as shown in Fig. 10, a surface of the deposition is melted by means of energy of the electric discharge and a thin film 47a composed of a structure of high density can be generated on the surface of the deposition 47. Meanwhile, when
20 generating the pulsing discharge, the hard electrode 31, as being integral with the processing head 21, is reciprocated in the Z-axis direction by a small travel distance by means of a drive of the Z-axis servo-motor 23.

(2-5) SECOND DEPOSITION STEP

After finishing the (2-4) thin film step, by means of
25 driving the X-axis servo-motor 9 and the Y-axis servo-motor 11, the table 7 is moved in the X-axis direction and the Y-axis direction to position the cylinder main body 37 so that the thin film 47a in the deposition 47 is opposed to the molded electrode 25. Meanwhile, there may be a case where the table 7 is only necessary
30 to be moved in any of the X-axis direction and the Y-axis direction.

Further, a pulsing electric discharge is generated between the thin film 47a in the deposition 47 and the molded electrode 25 in an electrically insulating liquid S. Thereby, as shown in Fig. 11, by means of energy of the electric discharge, a material
35 of the molded electrode 25 or a reaction substance of the material carries out deposition, diffusion and/or welding at the thin film 47a in the deposition 47 and thereby a deposition group 49

constituted of two layers of the depositions 47 can be gradually formed at the recess portion 39. Meanwhile, when generating the pulsing discharge, the molded electrode 25, as being integral with the processing head 21, is reciprocated in the Z-axis direction 5 by a small travel distance by means of a drive of the Z-axis servo-motor 23.

Here, dimensions of the deposition group 49 formed at the (2-5) second deposition step are made to be greater than dimensions of the recess portion 39. In concrete terms, an outer periphery 10 of the deposition group 49 is made to spread outward in 0.5mm or more relative to an outer periphery of the recess portion 39 and a thickness of the deposition group 49 is made to be thicker in 0.3 mm or more than a thickness required to filling the recess portion 39. Meanwhile, a part of the deposition group 49 becomes 15 an excessive deposition 49f sticking out of the recess portion 39. Thereby diffusion bonding among particles at the interior of the deposition group 49 can be generated.

(2-6) EXCESSIVE DEPOSITION REMOVAL STEP

After finishing the (2-5) second deposition step, by means 20 of driving the X-axis servo-motor 9 and the Y-axis servo-motor 11, the table 7 is moved in the X-axis direction and the Y-axis direction to position the cylinder main body 37 so that the deposition group 49 is opposed to the hard electrode 31. Meanwhile, there may be a case where the table 7 is only necessary to be moved 25 in any of the X-axis direction and the Y-axis direction.

Further, a pulsing electric discharge is generated between the deposition group 49 and the hard electrode 31 in an electrically insulating liquid S. Thereby, as shown in Fig. 12, by means of energy of the electric discharge, a thin film 49a composed of a 30 structure of high density can be generated as well as the excessive deposition 49f can be removed. Meanwhile, when generating the pulsing discharge, the hard electrode 31 is moved in the X-axis direction relative to the cylinder main body 37 and the hard electrode 31, as being integral with the processing head 21, is 35 reciprocated in the Z-axis direction by a small travel distance by means of a drive of the Z-axis servo-motor 23.

(2-7) HEAT TREATMENT STEP

After finishing the (2-6) excessive deposition removal step, the cylinder main body 37 is removed from the jig 17 and set at a predetermined position of the heat treatment furnace 43. Further, as shown in Fig. 13, the deposition group 49 accompanying the cylinder main body 37 is kept at a high temperature in a vacuum or in the air by means of the heat treatment furnace 43. Thereby, a heat treatment can be processed with respect to the deposition group 49 so as to progress diffusion bonding among the particles at the interior of the deposition group 49 and the production of the cylinder 45 as the metal product is finished.

Here, the temperature and the period of time are 20 minutes at a high temperature of 1050 degrees C and subsequently 4 hours at a high temperature of 760 degrees C in a case where the deposition group 49 is composed of a nickel alloy or a cobalt alloy.

Meanwhile, the production method of the metal product in accordance with the aforementioned first embodiment may be modified as in the following embodiment.

More specifically, the (2-6) excessive deposition removal step or the (2-7) heat treatment step can be omitted from the series of the steps in the production method of the metal production in accordance with the second embodiment or step orders of the (2-6) excessive deposition removal step and the (2-7) heat treatment step can be interchanged.

Moreover, instead of generating the pulsing discharge in the electrically insulating liquid S, a pulsing discharge may be generated in an electrically insulating gas.

Furthermore, by using a grinding lathe instead of the electric spark machine 1, the casing cavity periphery D' may be removed or the excessive 49f may be removed.

Moreover, instead of removing the casting cavity periphery D', any defect periphery including defects such as cracks may be removed.

Next, operations of the second embodiment will be described.

Because energy of the electric discharge locally acts on a prominently small part and the deposition group 49 is gradually formed by carrying out deposition, diffusion and/or welding of the material of the molded electrode 25 or such, a temperature

of the recess portion periphery 39' in the cylinder main body 37 is prevented from rapidly increasing at a time of producing the cylinder 45.

Moreover, because the deposition group 49 is formed by means of the energy of the electric discharge, a boundary part between the deposition group 49 and a base material of the cylinder main body 37 has a structure in which a composition ratio grades and hence the deposition group 49 can be firmly combined with the cylinder main body 37.

Furthermore, because the diffusion bonding among the particles at the interior of the deposition group 49 progresses, a tensile strength of the deposition group 49 can be increased.

In accordance with the second embodiment as described above, because the temperature of the recess portion periphery 39' in the cylinder main body 37 is prevented from rapidly increasing at the time of producing the cylinder 45, thermal deformation of the recess portion periphery 39' is sufficiently suppressed and hence defective production of the cylinder 45 is reduced to be almost none.

Moreover, because the deposition group 49 can be firmly combined with the cylinder main body 37, the deposition group 49 becomes unsusceptible to peeling off from the base material of the cylinder main body 37 and hence quality of the cylinder 45 can be stabilized.

Furthermore, because the tensile strength of the deposition group 49 can be increased, a mechanical strength of the recess portion periphery 39' in the cylinder main body 37 can be increased.

Moreover, because the deposition group 49 has the thin films 47a, 49a composed of the structures of high density, permeation of fluid out of the interior of the cylinder 45 can be suppressed.

(THIRD EMBODIMENT)

A cylinder 51 as a metal component which is a subject of a production method of a metal product in accordance with a third embodiment will be briefly described hereinafter with reference to Figs. 14-17.

The cylinder 51 as the metal component in accordance with the second embodiment is, as similar to the cylinder 35 in accordance

with the first embodiment and the cylinder 45 in accordance with the second embodiment, provided with a cylinder main body 37 as a product main body and, at an outer peripheral surface of the cylinder main body 37, a recess portion 39 is formed by means of energy of an electric discharge. Further, at a recess portion periphery 39' including the recess portion 39, a deposition group 53 constituted of plural layers of depositions 47 is formed by means of energy of an electric discharge. Meanwhile, details of the deposition group 53 will be described later.

10 Next, the production method of the metal product in accordance with the third embodiment will be described hereinafter with reference to Fig. 1, Fig. 3, Fig. 4, Fig. 9, Fig. 10 and from Fig. 15 to Fig. 17.

15 The production method of the metal product in accordance with the third embodiment is a method for producing the cylinder 51 as the metal component and employs the electric spark machine 1, the molded electrode 25, the hard electrode 31 and the heat treatment furnace 43 as described above.

20 Further, the production method of the metal product in accordance with the third embodiment is provided with a (3-1) molding step, a (3-2) defect removal step, a (3-3) deposition step, a (3-4) thin film step, a (3-5) repetition step, an (3-6) excessive deposition removal step and a (3-7) heat treatment step.

(3-1) MOLDING STEP

25 This step is carried out in the same manner as the aforementioned (1-1) molding step. (see Fig. 3)

(3-2) DEFECT REMOVAL STEP

This step is carried out in the same manner as the aforementioned (1-2) defect removal step. (see Fig. 4)

30 (3-3) DEPOSITION STEP

This step is carried out in the same manner as the aforementioned (2-3) first deposition step. (see Fig. 9)

(3-4) THIN FILM STEP

35 This step is carried out in the same manner as the aforementioned (2-4) thin film step. (see Fig. 10)

(3-5) REPETITION STEP

After finishing the (3-4) thin film step, the (3-3) deposition

step and the (3-4) thin film step are alternately repeated. Thereby, as shown in Fig. 15, thin films 47a are generated on the surfaces of the respective layers of the depositions 47 and the deposition group 53 composed of the plural layers of the depositions 47 can be formed at the recess portion 39 by means of energy of the electric discharge.

Here, dimensions of the deposition group 53 formed at the (3-5) repetition step are made to be greater than dimensions of the recess portion 39. In concrete terms, an outer periphery of the deposition group 53 is made to spread outward in 0.5mm or more relative to an outer periphery of the recess portion 39 and a thickness of the deposition group 53 is made to be thicker in 0.3 mm or more than a thickness required to filling the recess portion 39. Thereby diffusion bonding among particles at the interior of the deposition group 53 can be generated.

Meanwhile, a part of the deposition group 53 becomes an excessive deposition 53f sticking out of the recess portion 39. Thereby diffusion bonding among particles at the interior of the deposition group 53 can be generated.

(3-6) EXCESSIVE DEPOSITION REMOVAL STEP

After finishing the (3-5) repetition step, by means of driving the X-axis servo-motor 9 and the Y-axis servo-motor 11, the table 7 is moved in the X-axis direction and the Y-axis direction to position the cylinder main body 37 so that the deposition group 53 is opposed to the hard electrode 31. Meanwhile, there may be a case where the table 7 is only necessary to be moved in any of the X-axis direction and the Y-axis direction.

Further, a pulsing electric discharge is generated between the deposition group 53 and the hard electrode 31 in an electrically insulating liquid S. Thereby, as shown in Fig. 16, by means of energy of the electric discharge, a thin film 53a composed of a structure of high density can be generated as well as the excessive deposition 53f can be removed. Meanwhile, when generating the pulsing discharge, the hard electrode 31 is moved in the X-axis direction relative to the cylinder main body 37 and the hard electrode 31, as being integral with the processing head 21, is reciprocated in the Z-axis direction by a small travel distance by means of a drive of the Z-axis servo-motor 23.

(3-7) HEAT TREATMENT STEP

After finishing the (3-5) excessive deposition removal step, the cylinder main body 37 is removed from the jig 17 and set at a predetermined position of the heat treatment furnace 43. Further, 5 as shown in Fig. 17, the deposition group 53 accompanying the cylinder main body 37 is kept at a high temperature in a vacuum or in the air by means of the heat treatment furnace 43. Thereby, a heat treatment can be processed with respect to the deposition group 53 so as to progress diffusion bonding among the particles 10 at the interior of the deposition group 53 and the production of the cylinder 51 as the metal product is finished.

Here, the temperature and the period of time are 20 minutes at a high temperature of 1050 degrees C and subsequently 4 hours at a high temperature of 760 degrees C in a case where the deposition 15 group 53 is composed of a nickel alloy or a cobalt alloy.

Meanwhile, the production method of the metal product in accordance with the aforementioned third embodiment may be modified as in the following embodiment.

More specifically, the (3-6) excessive deposition removal 20 step or the (3-7) heat treatment step can be omitted from the series of the steps in the production method of the metal production in accordance with the second embodiment or steps orders of the (3-6) excessive deposition removal step and the (3-7) heat treatment step can be interchanged.

Moreover, instead of generating the pulsing discharge in 25 the electrically insulating liquid S, a pulsing discharge may be generated in an electrically insulating gas.

Furthermore, by using a grinding lathe instead of the electric spark machine 1, the casing cavity periphery D' may be removed 30 or the excessive 53f may be removed.

Moreover, instead of removing the casting cavity periphery D', any defect periphery including defects such as cracks may be removed.

Next, operations of the third embodiment will be described. 35 Because energy of the electric discharge locally acts on a prominently small part and the deposition group 53 is gradually formed by carrying out deposition, diffusion and/or welding of

the material of the molded electrode 25 or such, a temperature of the recess portion periphery 39' in the cylinder main body 37 is prevented from rapidly increasing at a time of producing the cylinder 51.

5 Moreover, because the deposition group 53 is formed by means of the energy of the electric discharge, a boundary part between the deposition group 53 and a base material of the cylinder main body 37 has a structure in which a composition ratio grades and hence the deposition group 53 can be firmly combined with the
10 cylinder main body 37.

Furthermore, because the diffusion bonding among the particles at the interior of the deposition group 53 progresses, a tensile strength of the deposition group 53 can be increased.

In accordance with the third embodiment as described above,
15 because the temperature of the recess portion periphery 39' in the cylinder main body 37 is prevented from rapidly increasing at the time of producing the cylinder 51, thermal deformation of the recess portion periphery 39' is sufficiently suppressed and hence defective production of the cylinder 51 is reduced to be
20 almost none.

Moreover, because the deposition group 53 can be firmly combined with the cylinder main body 37, the deposition group 53 becomes unsusceptible to peeling off from the base material of the cylinder main body 37 and hence quality of the cylinder 51
25 can be stabilized.

Furthermore, because the tensile strength of the deposition group 53 can be increased, a mechanical strength of the recess portion periphery 39' in the cylinder main body 37 can be increased.

Moreover, because the deposition group 53 has the thin films
30 47a, 53a composed of the structures of high density, permeation of fluid out of the interior of the cylinder 51 can be suppressed.

(FOURTH EMBODIMENT)

A joint structure 55 in accordance with a fourth embodiment will be described hereinafter with reference to Figs. 18-21.

35 The joint structure 55 is provided with a pair of metal components 57, 59 which are butted with each other and, in this condition, joined with each other and the pair of the metal component

57, 59 are respectively provided with beveling portions 57a, 59a. Moreover, a recess portion 61 is defined by the beveling portion 57a of the metal component 57 and the beveling portion 59a of the other metal component 59 and a deposition 63 is formed at a recess portion periphery 61' including the recess portion 61 by energy of the electric discharge. Further, the deposition 63 is gradually formed by employing the molded electrode 27 shown in Fig. 1, generating a pulsing electric discharge between the recess portion periphery 61' including the recess portion 61 and the molded electrode 27 in an electrically insulating liquid or gas so that a material of the molded electrode 27 or a reaction substance of the material carries out deposition, diffusion and/or welding at the recess portion periphery 61' by energy of the electric discharge.

15 Here, the molded electrode 27 is composed of a molded body molded from powder of a material having the same composition as the metal components 57, 59, powder of a material having the similar composition to the metal components 57, 59, or powder of a material having a coefficient of thermal expansion close to a coefficient of thermal expansion of a base material of the metal component 20 57, 59 by means of compression by pressing; or the molded body subject to a heat treatment by a vacuum furnace or such.

25 Meanwhile, in a case where the base material of the metal component 57, 59 is a stainless alloy of iron including 18% of chromium and 8% of nickel, another stainless steels having different contents become the material having the similar composition and cobalt or cobalt alloys become the material having the coefficient of the thermal expansion close thereto. Moreover, instead of molding by compressing, the molded electrode 27 may be formed by 30 slurry pouring, MIM (Metal Injection Molding), spray forming and such.

Next, the production method of the joining method of the metal components in accordance with the fourth embodiment will be described hereinafter with reference to Fig. 1 and from Fig. 35 19 to Fig. 21.

The joining method of the metal components in accordance with the fourth embodiment is a method for joining the pair of

the metal components 57, 59 and employing the electric spark machine 1, the molded electrode 27 and the heat treatment furnace 43 as described above. Further, the joining method of the metal components in accordance with the fourth embodiment is provided
5 with a (4-1) butting step, a (4-2) deposition step, and a (4-3) heat treatment step as described below.

(4-1) BUTTING STEP

The pair of the metal components 57, 59 are set to the jig 17 so that the pair of the metal components 57, 59 are butted with
10 each other. Thereby, the recess portion 61 is defined by the beveling portion 57a of the metal component 57 and the beveling portion 59a of the other metal component 59 as shown in Fig. 19.

(4-2) DEPOSITION STEP

After finishing the (4-1) butting step, by means of driving
15 the X-axis servo-motor 9 and the Y-axis servo-motor 11, the table 7 is moved in the X-axis direction and the Y-axis direction to position the pair of the metal components 57, 59 so that the recess portion periphery 61' is opposite to the molded electrode 27. Meanwhile, there may be a case where the table 7 is only necessary
20 to be moved in any of the X-axis direction and the Y-axis direction.

Further, a pulsing electric discharge is generated between the recess portion periphery 61' and the molded electrode 27 in an electrically insulating liquid S. Thereby, as shown in Fig. 20, by means of energy of the electric discharge, a material of
25 the molded electrode 27 or a reaction substance of the material carries out deposition, diffusion and/or welding at the recess portion periphery 61' and thereby a deposition 63 can be gradually formed at the recess portion periphery 61'. Meanwhile, when generating the pulsing discharge, the molded electrode 27, as being
30 integral with the processing head 21, is reciprocated in the Z-axis direction by a small travel distance by means of a drive of the Z-axis servo-motor 23.

Here, dimensions of the deposition 63 are made to be greater than dimensions of the recess portion 61. In concrete terms, an
35 outer periphery of the deposition 63 is made to spread outward in 0.5mm or more relative to an outer periphery of the recess portion 61 and a thickness of the deposition 63 is made to be thicker in

0.3mm or more than a thickness required to filling the recess portion 61. Thereby diffusion bonding among particles at the interior of the deposition 63 can be generated.

(4-3) HEAT TREATMENT STEP

5 After finishing the (4-2) deposition step, the pair of the metal components 57, 59 are removed from the jig 17 and set at a predetermined position of the heat treatment furnace 43. Further, the deposition 63 accompanying the pair of the metal components 57, 59 is kept at a high temperature in a vacuum or in the air
10 by means of the heat treatment furnace 43. Thereby, a heat treatment can be processed with respect to the deposition 63 so as to progress diffusion bonding among the particles at the interior of the deposition 63 and joining of the pair of the metal components 57, 59 is finished.

15 Here, the temperature and the period of time are 20 minutes at a high temperature of 1050 degrees C and subsequently 4 hours at a high temperature of 760 degrees C in a case where the deposition 63 is composed of a nickel alloy or a cobalt alloy.

20 Meanwhile, the joining method of the metal components in accordance with the aforementioned fourth embodiment may be modified as in the following embodiment.

 More specifically, the (4-3) heat treatment step can be omitted from the series of the steps in the joining method of the metal components in accordance with the fourth embodiment.

25 Moreover, between the (4-2) deposition step and the (4-3) heat treatment step, an excessive deposition may be removed.

 Furthermore, instead of generating the pulsing discharge in the electrically insulating liquid S, a pulsing discharge may be generated in an electrically insulating gas.

30 Next, operations of the fourth embodiment will be described.

 Because energy of the electric discharge locally acts on a prominently small part and the deposition 63 is gradually formed by carrying out deposition, diffusion and/or welding of the material of the molded electrode 27 or such, a temperature of the recess portion periphery 61' in the metal components 57, 59 is prevented
35 from rapidly increasing at a time of joining the pair of the metal components 57, 59.

Moreover, because the deposition 63 is formed by means of the energy of the electric discharge, a boundary part between the deposition 63 and a base material of the metal components 57, 59 has a structure in which a composition ratio grades and hence the
5 deposition 63 can be firmly combined with the metal components 57, 59.

Furthermore, because the diffusion bonding among the particles at the interior of the deposition 63 progresses, a tensile strength of the deposition 63 can be increased.

10 In accordance with the fourth embodiment as described above, because the temperature of the recess portion periphery 61' in the metal components 57, 59 is prevented from rapidly increasing at the time of joining the pair of the metal components 57, 59, thermal deformation of the recess portion periphery 61' is
15 sufficiently suppressed and hence defective joining of the pair of the metal components is reduced to be almost none.

Moreover, because the deposition 63 can be firmly combined with the metal components 57, 59 and the tensile strength of the deposition 63 can be increased, the condition of the joint between
20 the pair of the metal components 57, 59 comes to be firm, in other words, a mechanical strength of the joint structure 55 can be increased.

The invention has been described above by reference to several preferable embodiments; however, the scope of the
25 appended claims should not be limited to these embodiments.

What is claimed is:

1. A method for production of a metal product, comprising steps of:

molding a main body of a metal;

removing a portion defining a defect included in the main body to form a recess portion;

depositing a deposition from a deposition tool electrode formed by compressing a powder consisting essentially of the metal to fill the recess portion by processing the main body as a workpiece of an electric spark machine opposed to the deposition tool electrode; and

eliminating a projecting portion of the deposition.

2. The method of claim 1, wherein the step of removing is carried out by processing the defect as the workpiece of the electric spark machine opposed to an electrode composed of a solid substance having graphite, tungsten alloys or cooper alloys.

3. The method of claim 1, wherein the step of molding includes a step of casting the main body and the defect includes a casting cavity.

4. A method for production of a metal product, comprising steps of:

molding a main body of a metal;

removing a portion defining a defect included in the main body to form a recess portion;

depositing a deposition from a deposition tool electrode formed by compressing a powder consisting essentially of the metal to fill the recess portion by processing the main body as a workpiece of an electric spark machine opposed to the deposition tool electrode;

melting the deposition in part to form a thin film from the melted deposition by processing the deposition as the workpiece of the electric spark machine opposed to an electrode composed of a solid substance having graphite, tungsten alloys or cooper alloys;

forming a second deposition from the deposition electrode on the thin film and the deposition by processing the deposition as the workpiece of the electric spark machine opposed to the deposition electrode; and

eliminating a projecting portion of the second deposition.

5. The method of claim 4, wherein the step of eliminating is carried out by processing the projecting portion as the workpiece of the electric spark machine opposed to the hard electrode.

6. The method of claim 4, further comprising a step of: treating the deposition, the thin film, and the second deposition with a heat treatment sufficient to progress diffusion bonding among particles of the depositions.

7. The method of claim 4, wherein the steps of depositing and melting are reciprocally carried out.

8. The method of claim 7, further comprising a step of:
treating the depositions and the thin films with a heat treatment sufficient to progress diffusion bonding among particles of the depositions.

9. The method of claim 4, wherein the step of molding includes a step of casting the main body and the defect includes a casting cavity.

FIG. 1

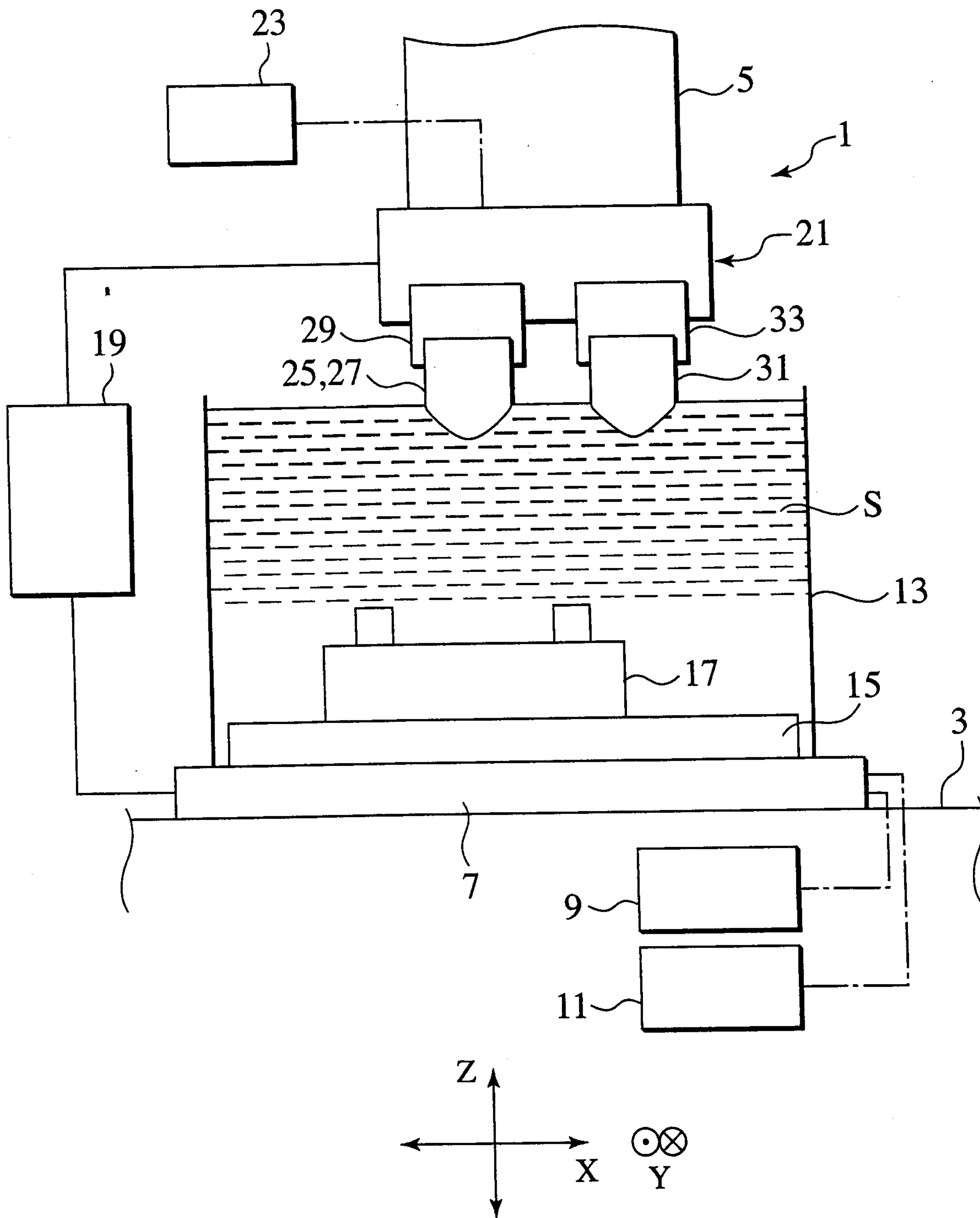

FIG.2

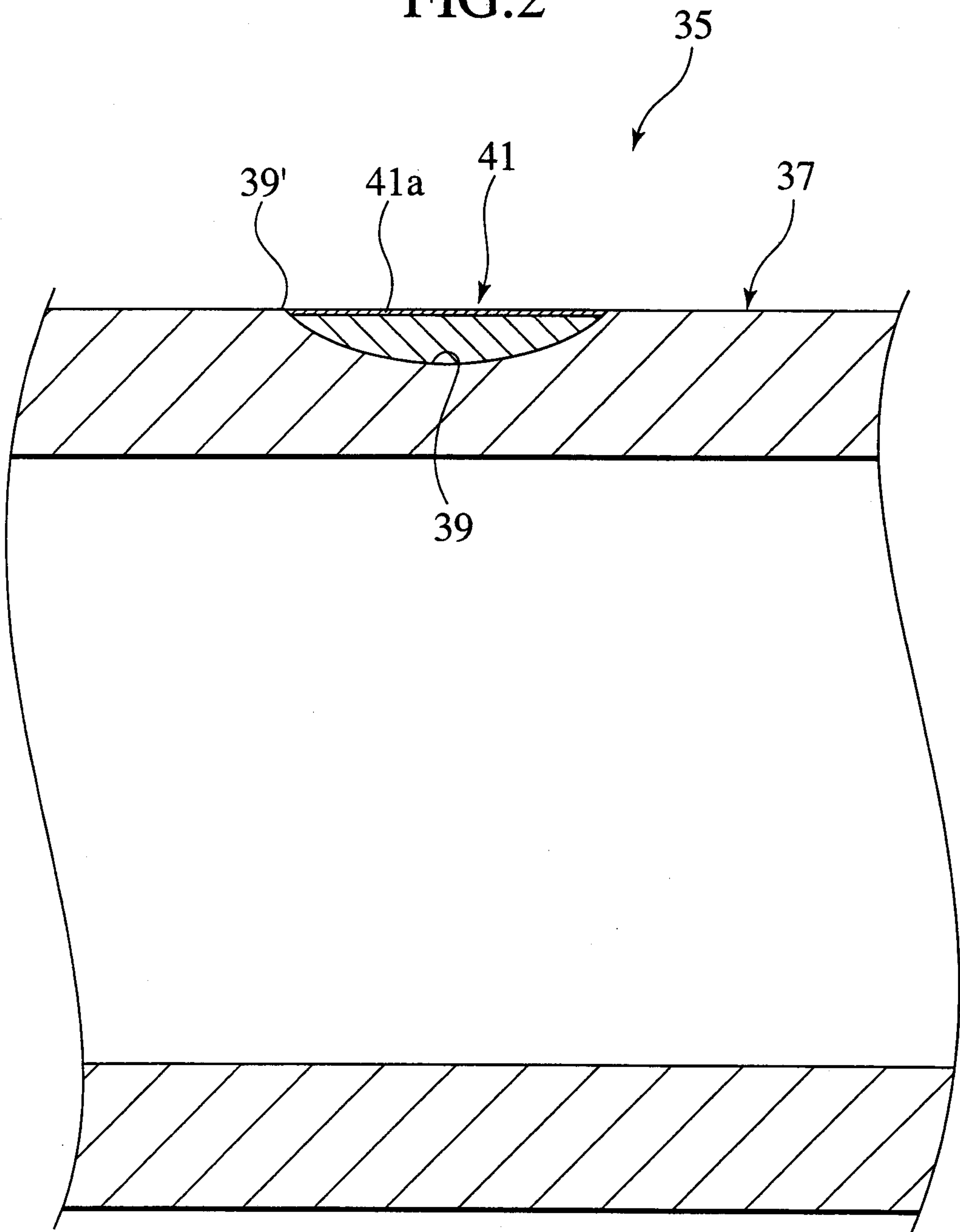

FIG.3

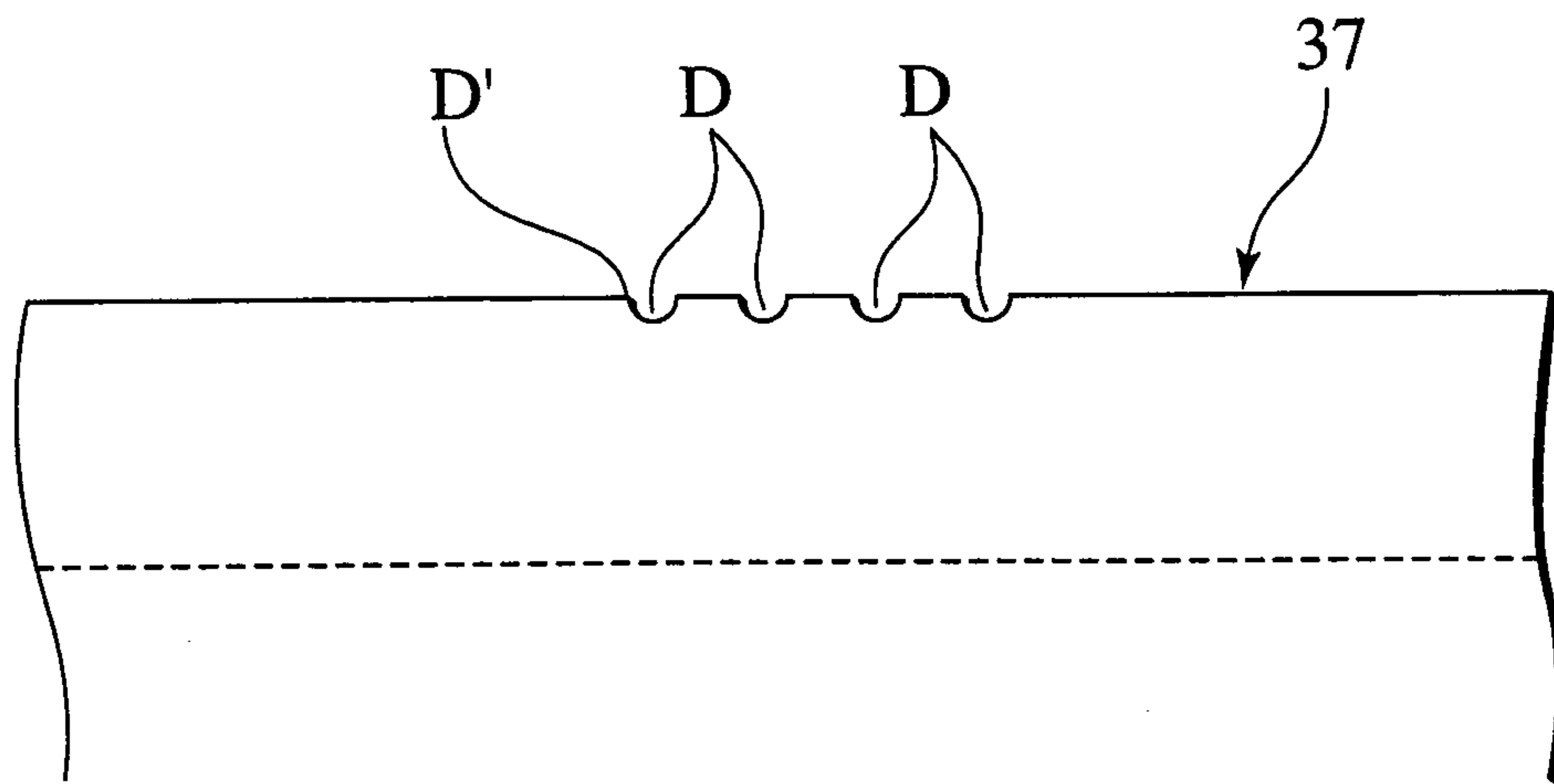
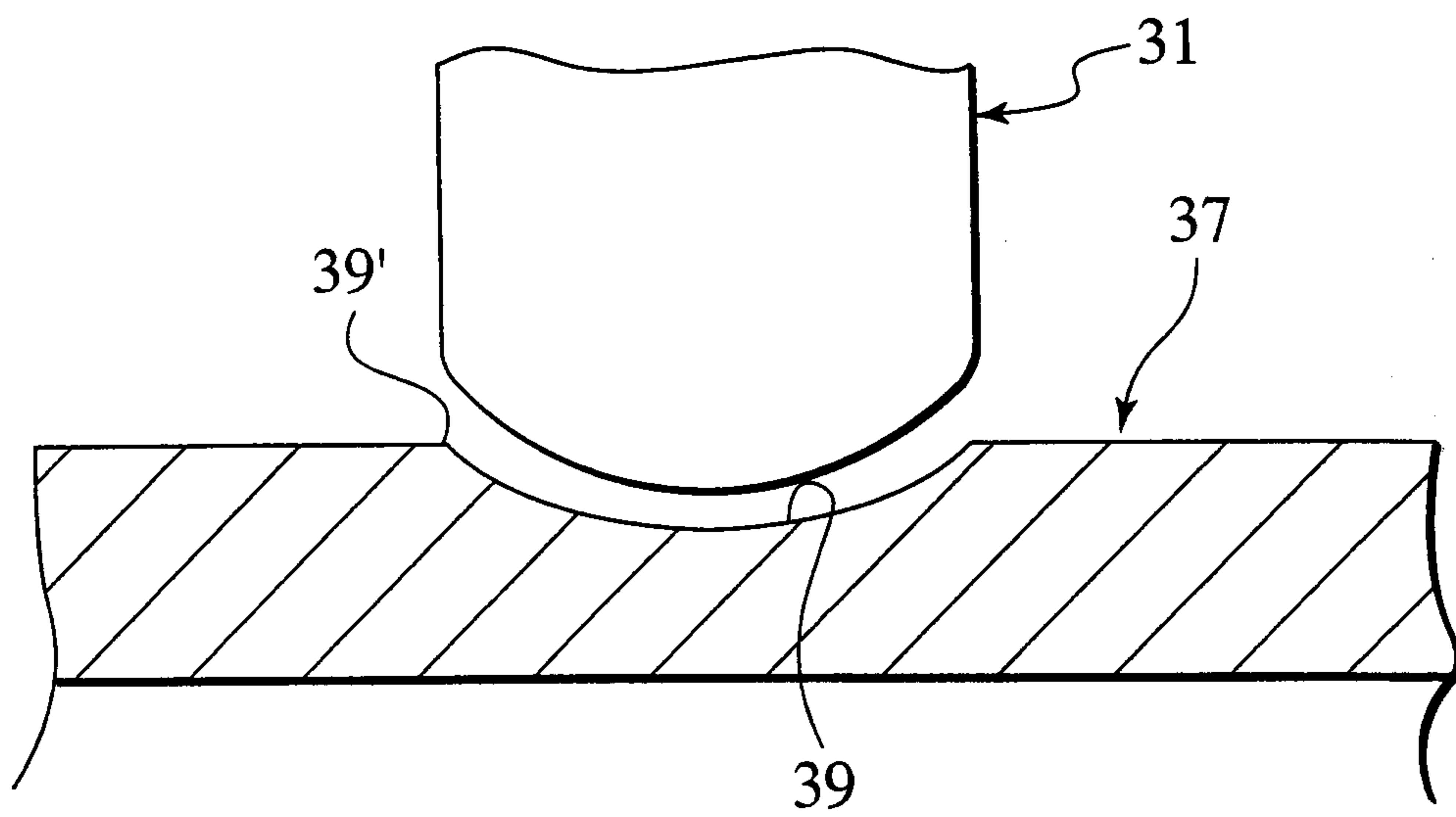

FIG.4



4/14

FIG.5

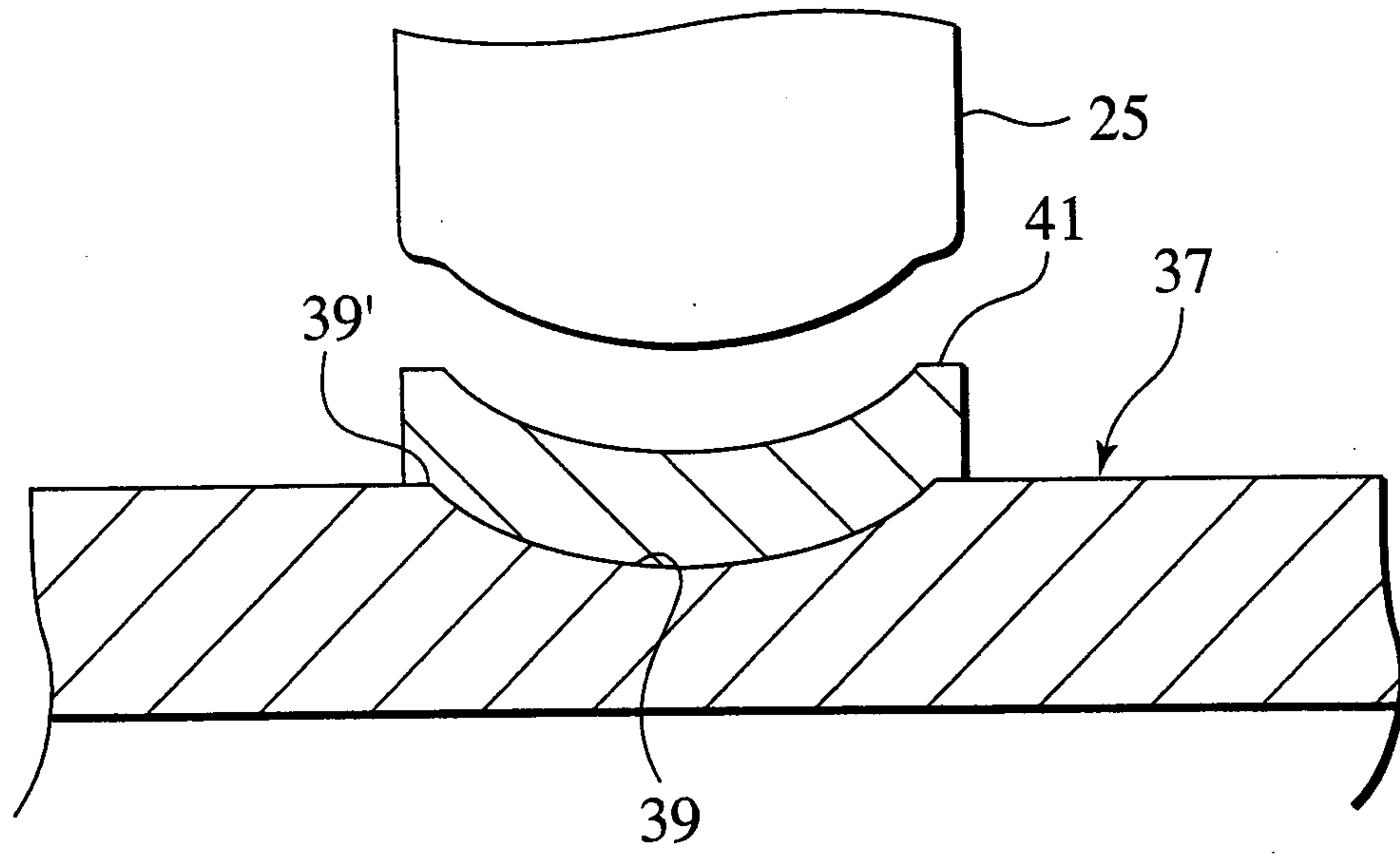

FIG.6

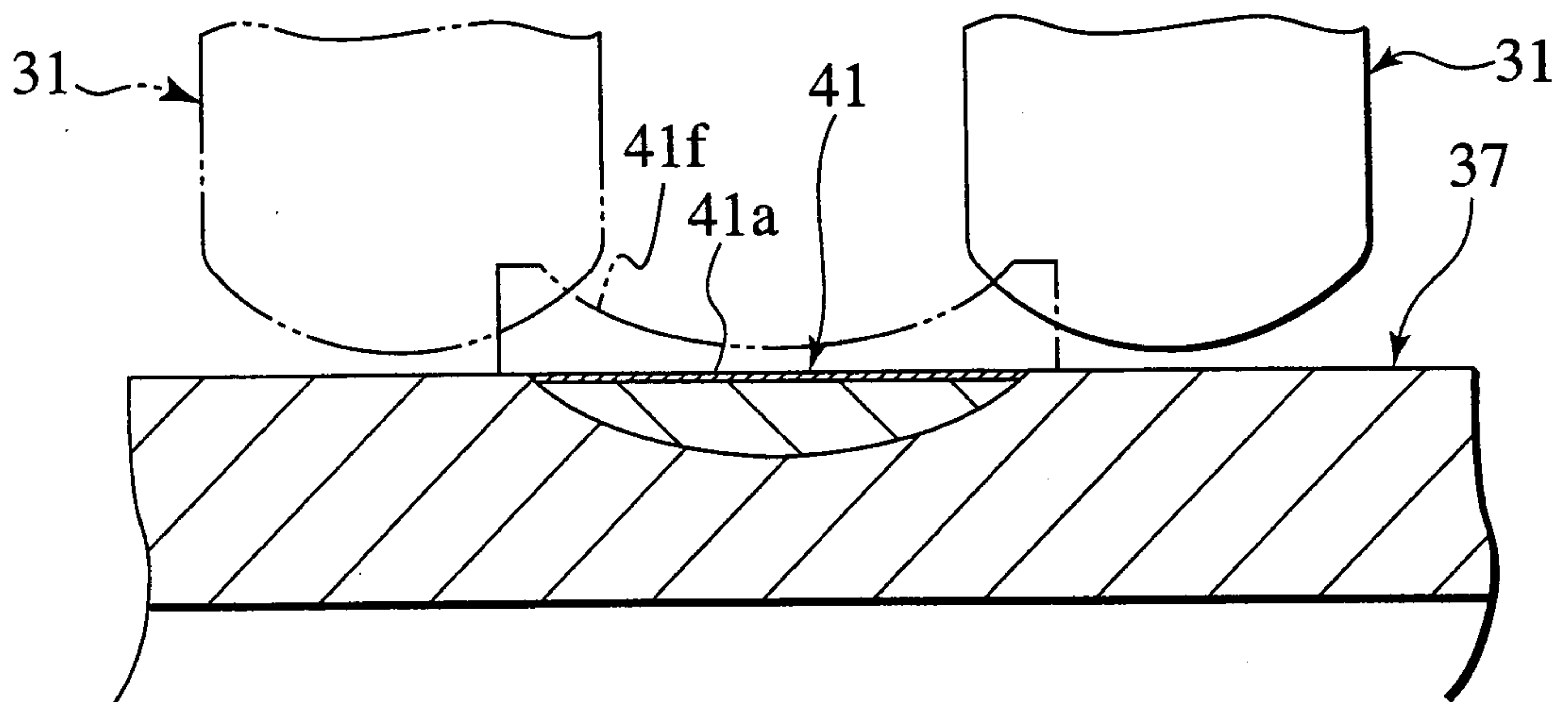
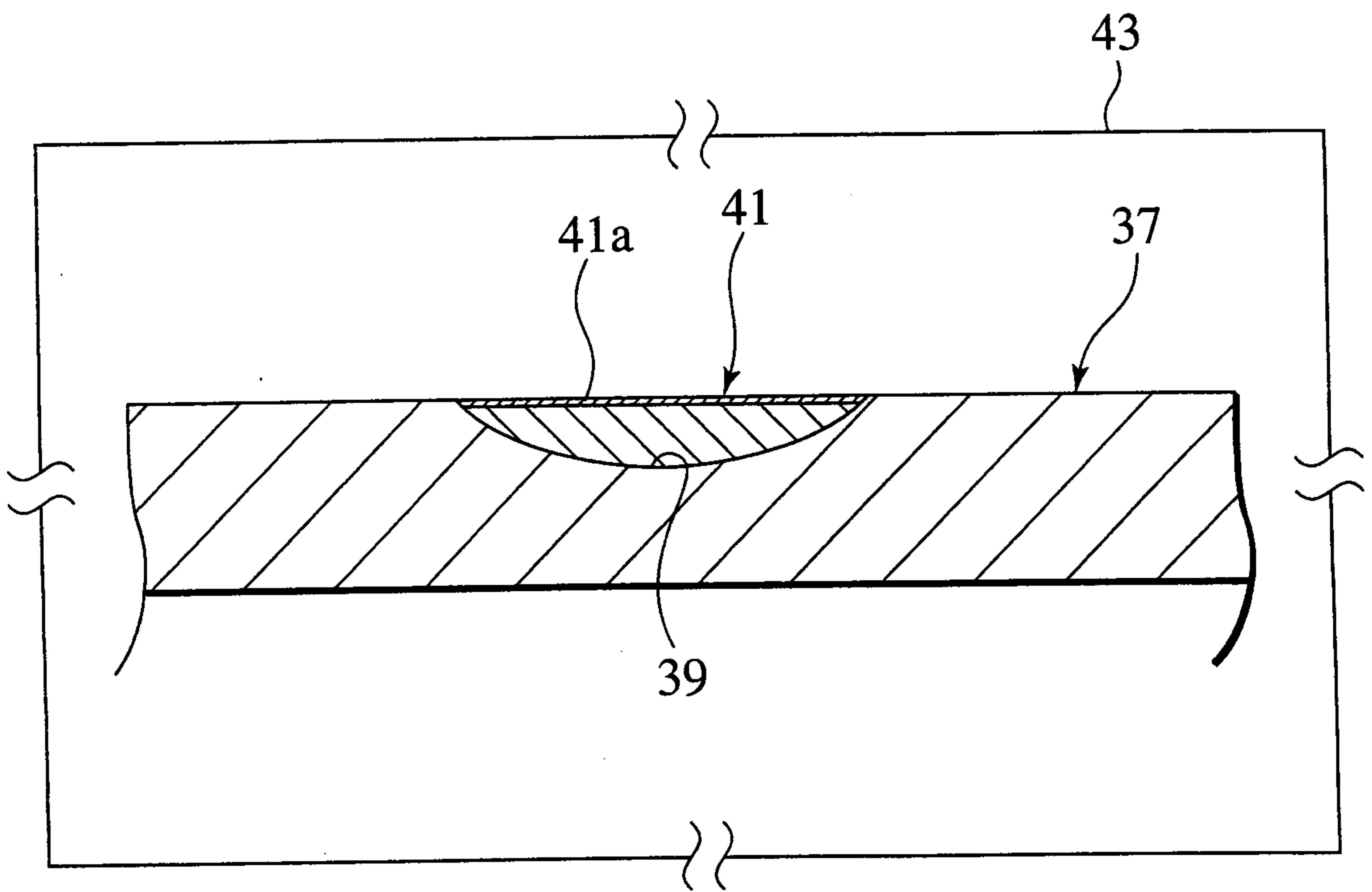
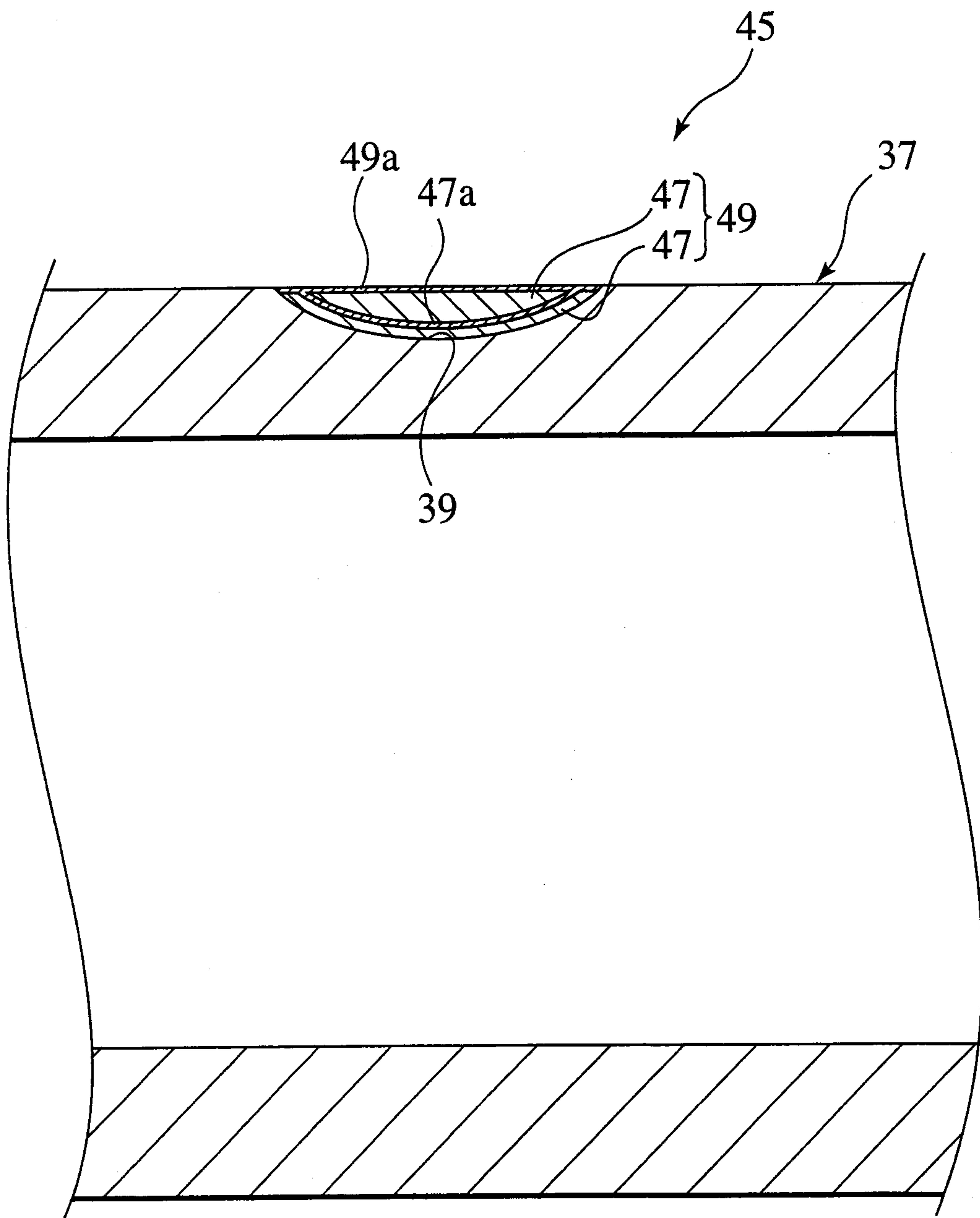

FIG. 7



6/14

FIG. 8



7/14

FIG.9

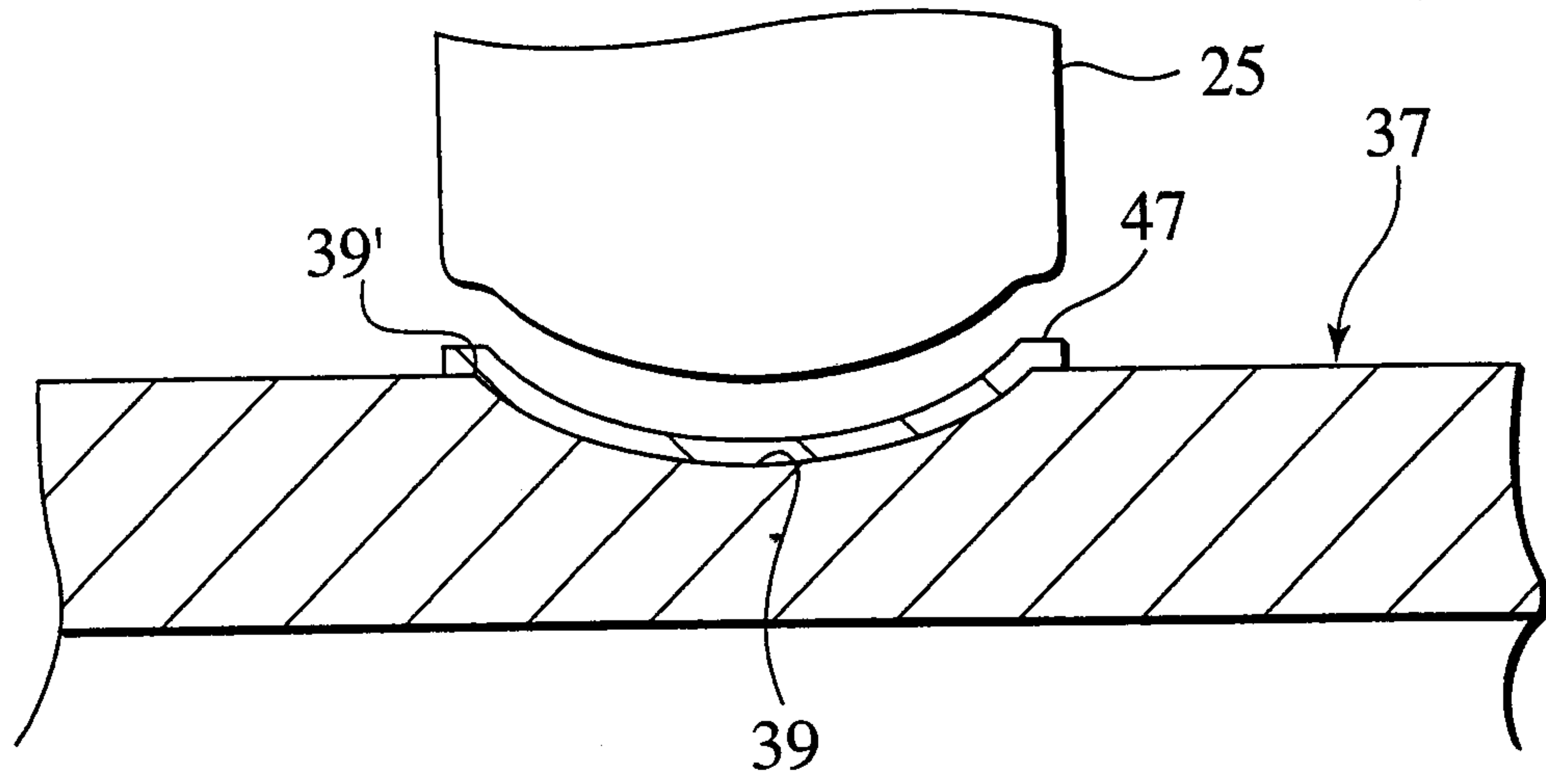

FIG.10

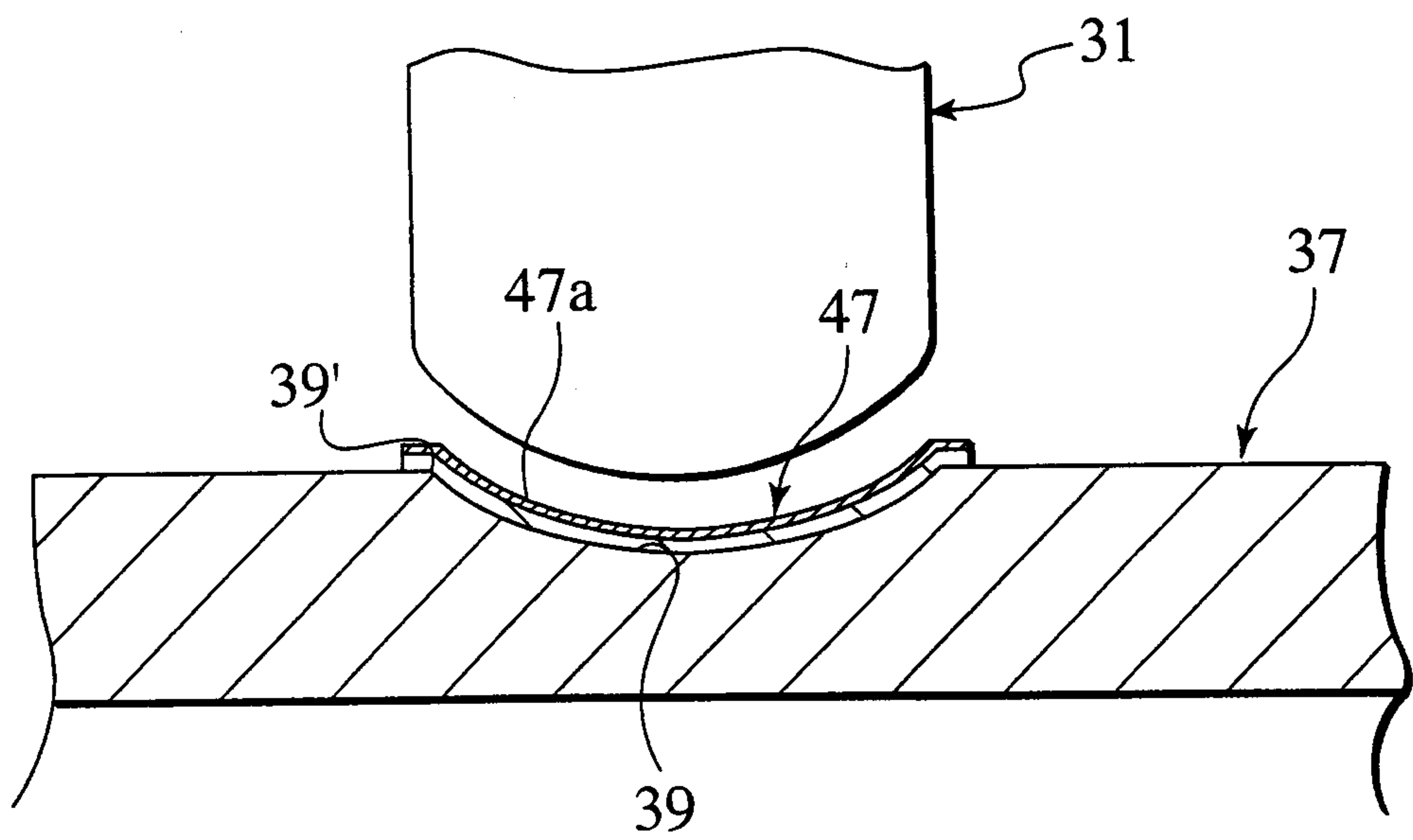

FIG.11

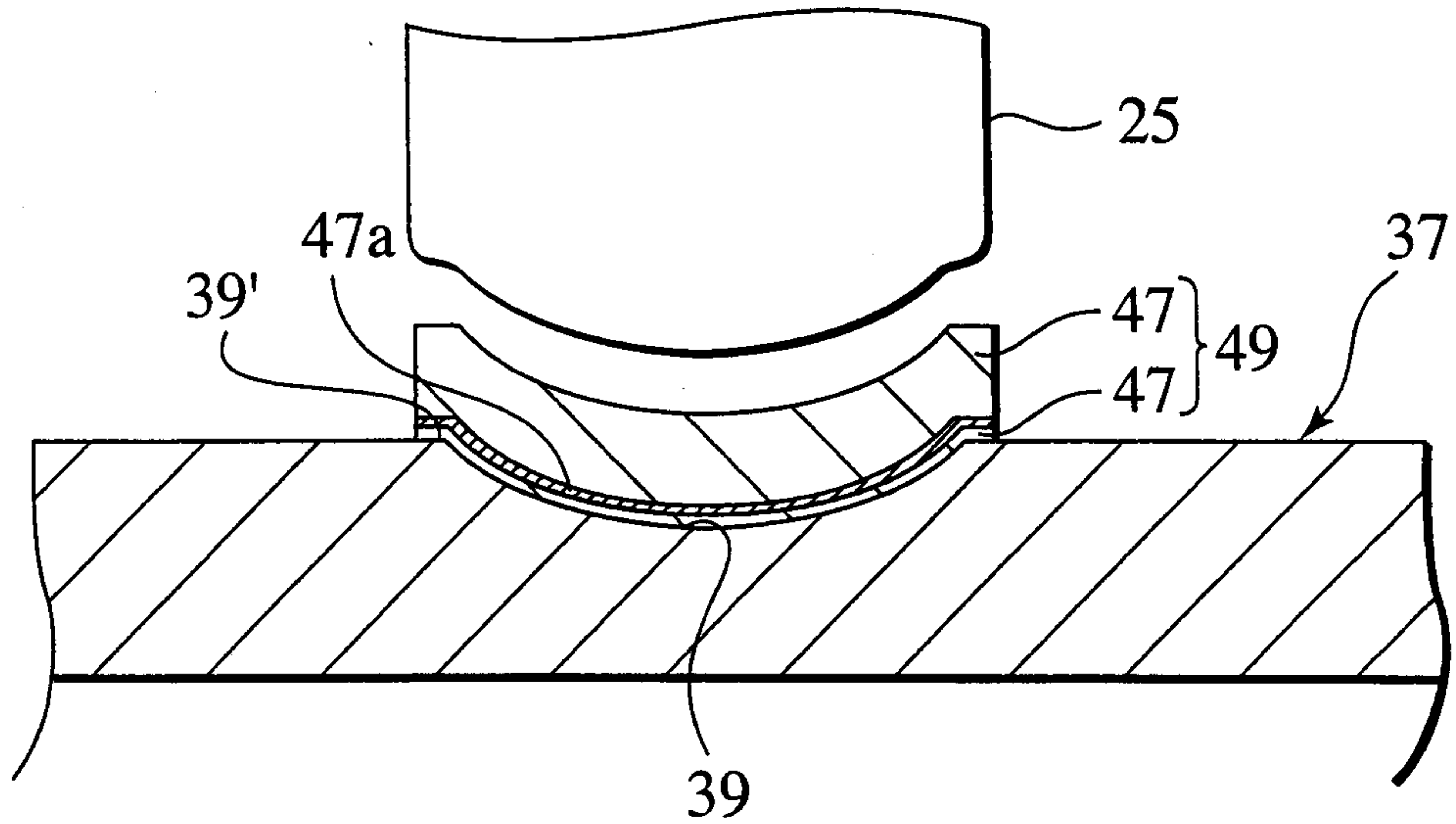

FIG.12

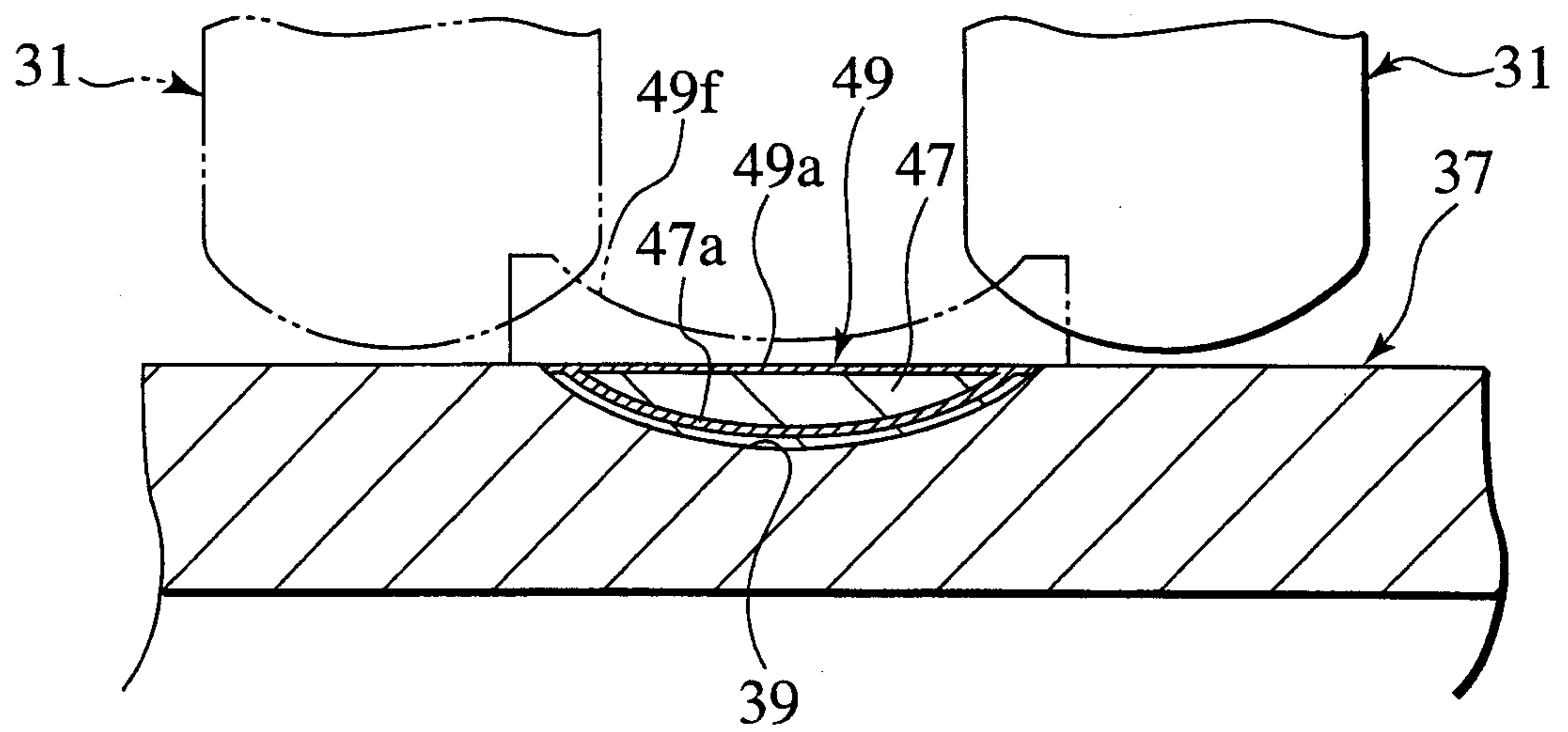
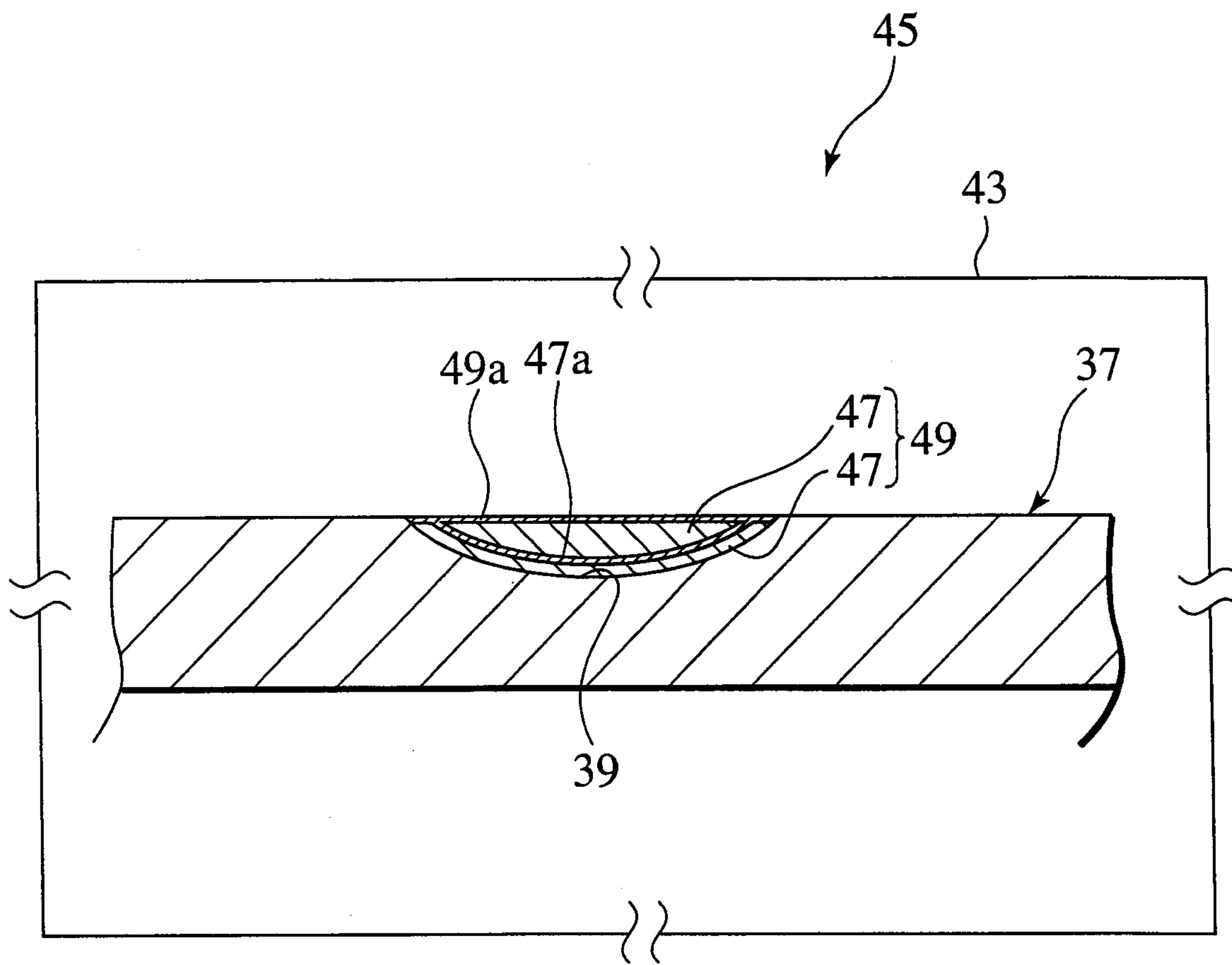
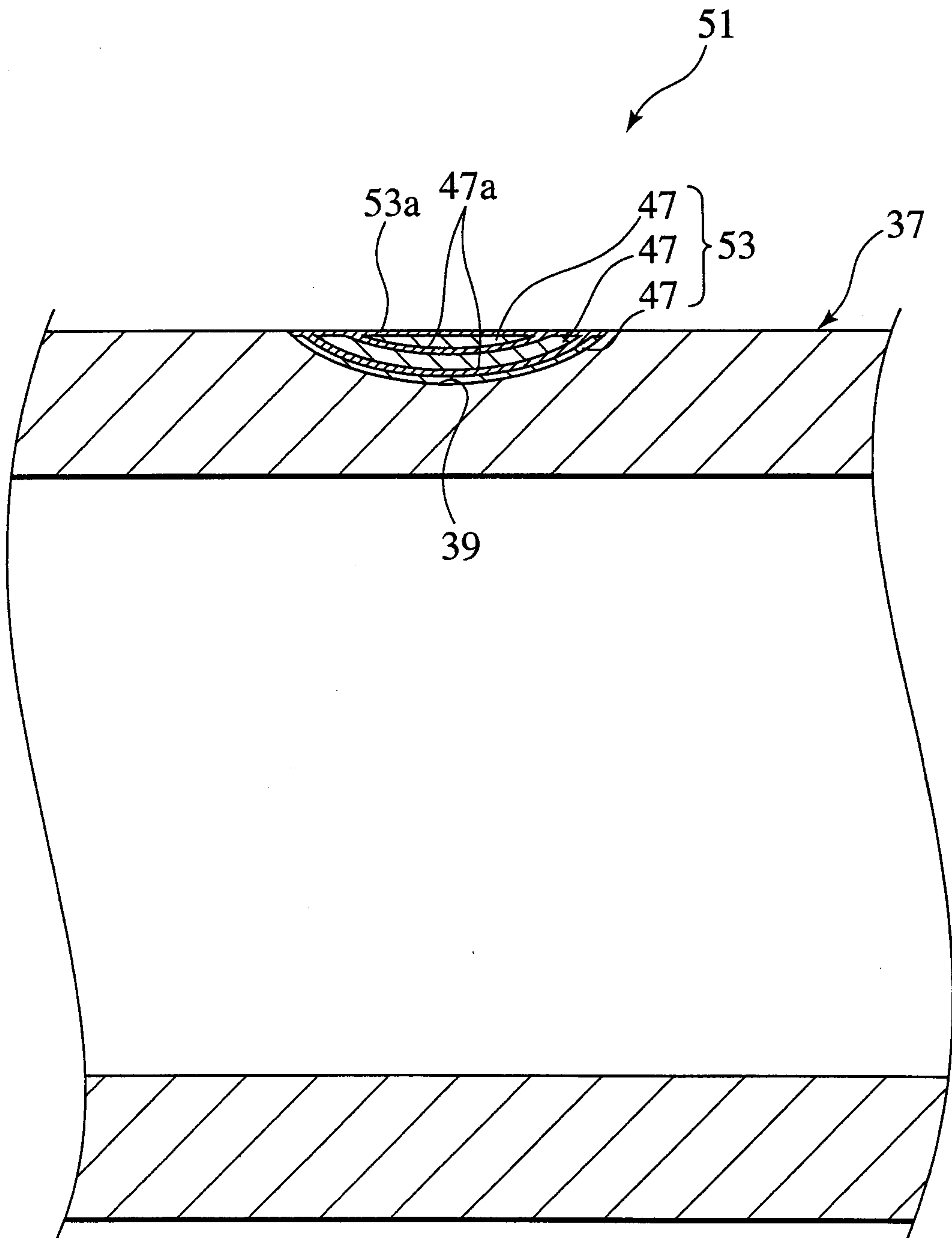

FIG. 13



10/14

FIG. 14



11/14

FIG.15

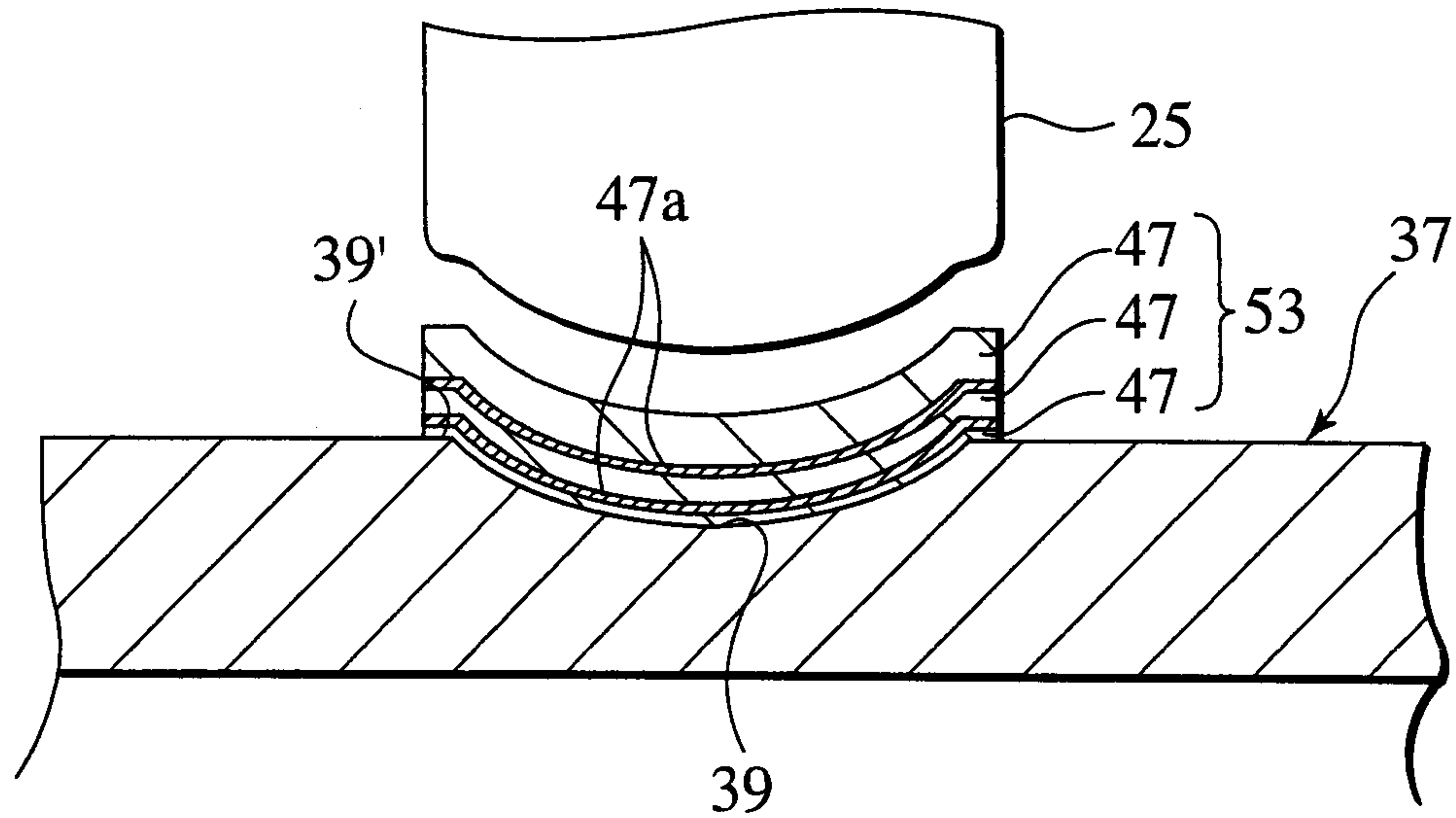

FIG.16

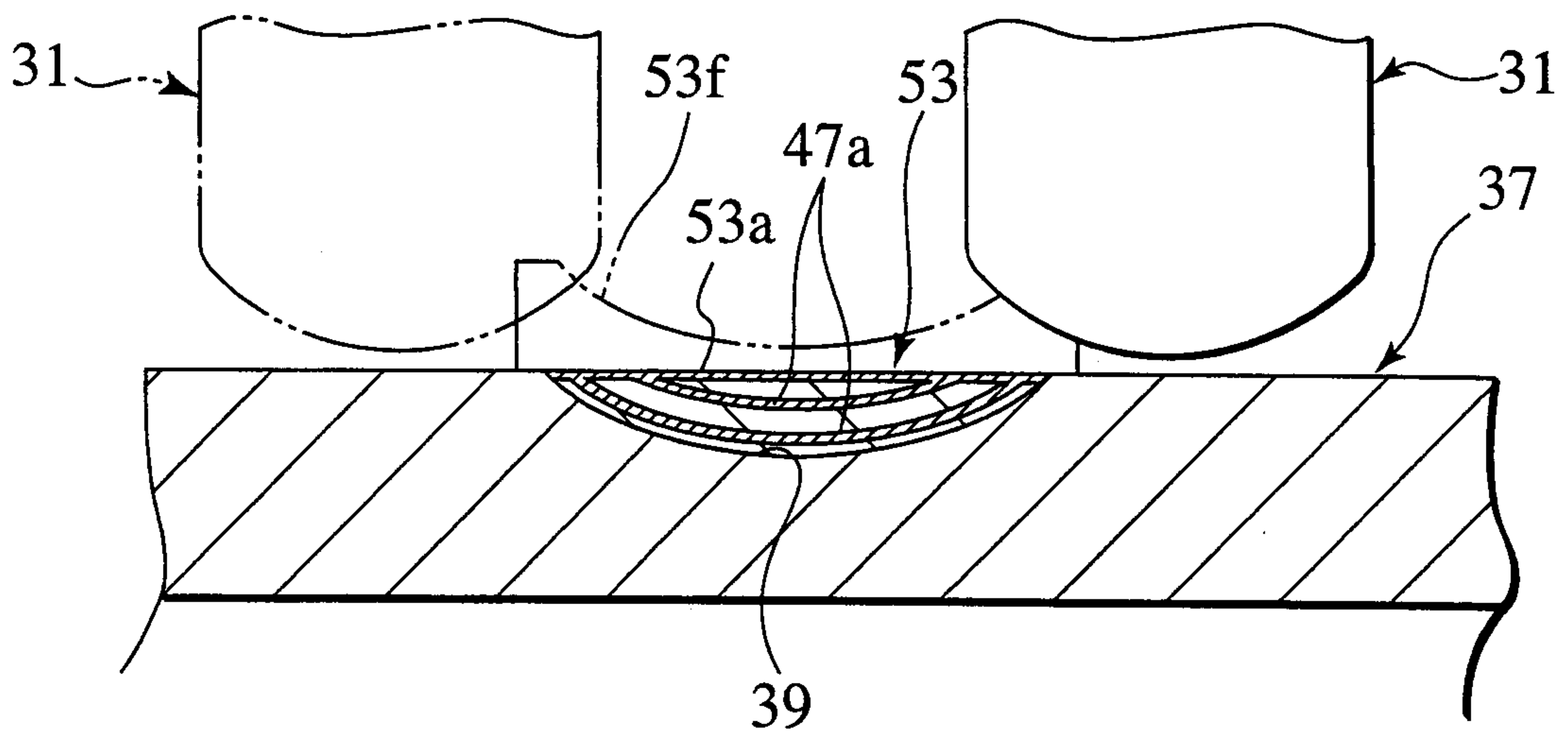

FIG. 17

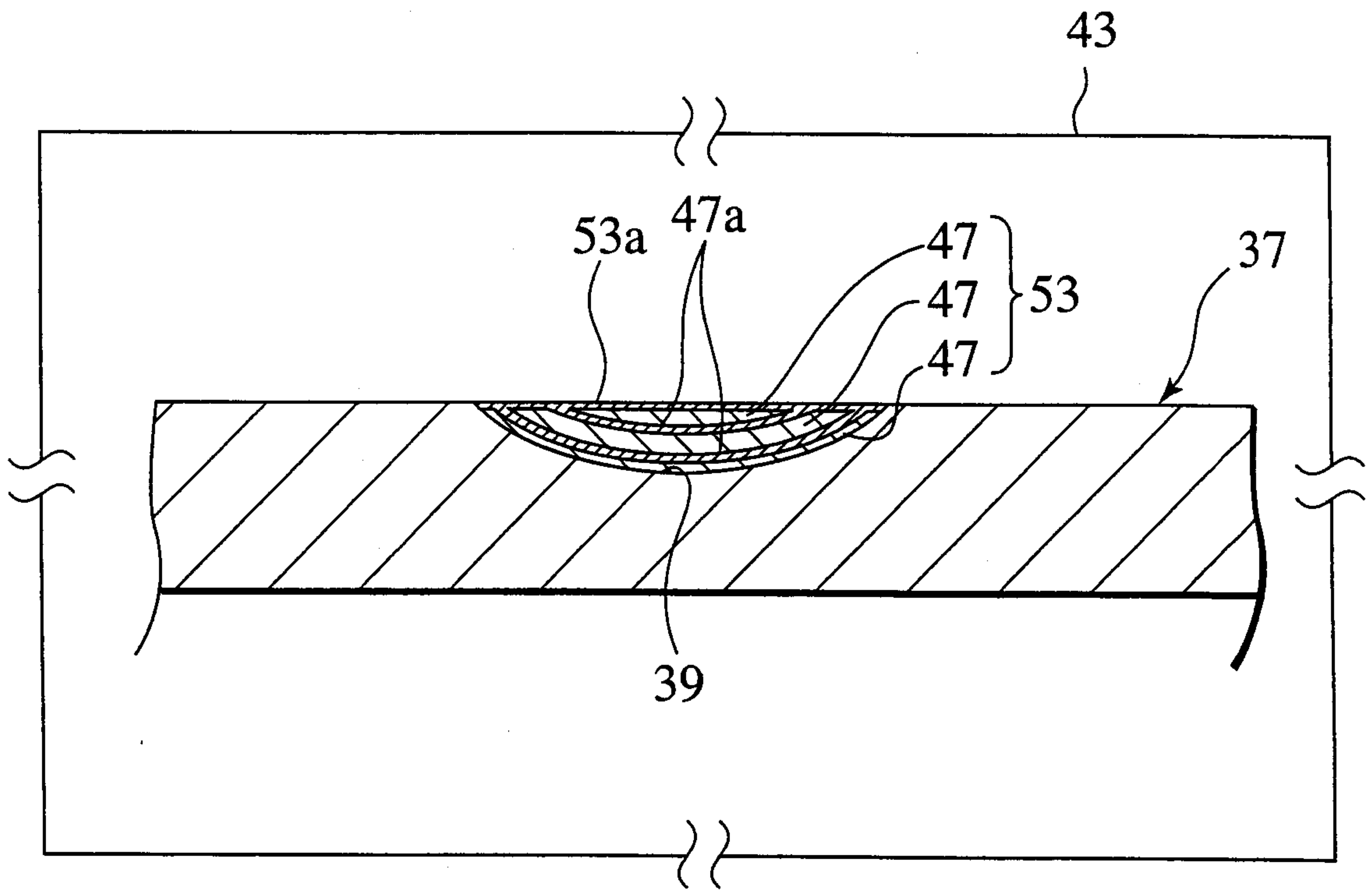

FIG. 18

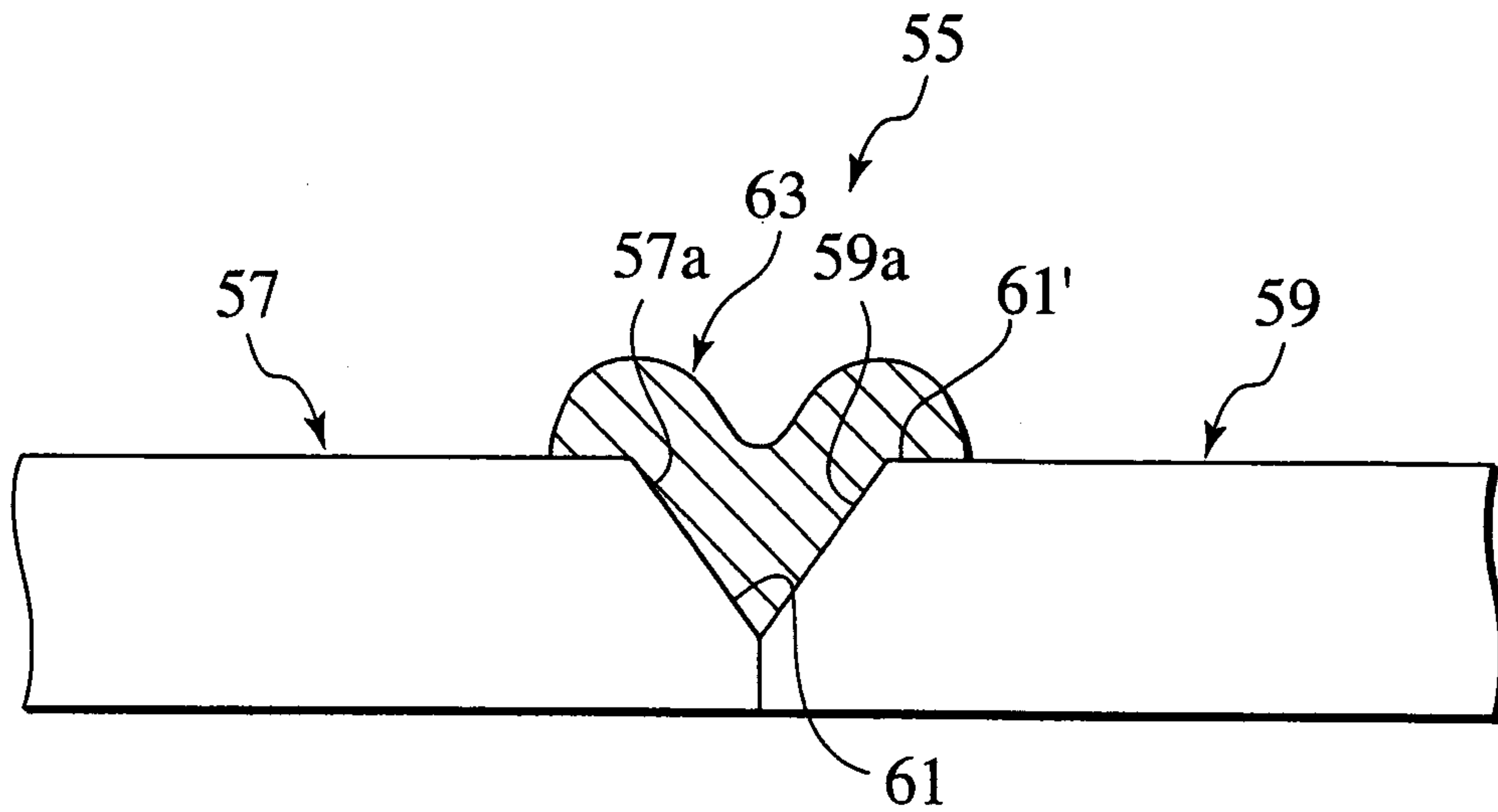

FIG. 19

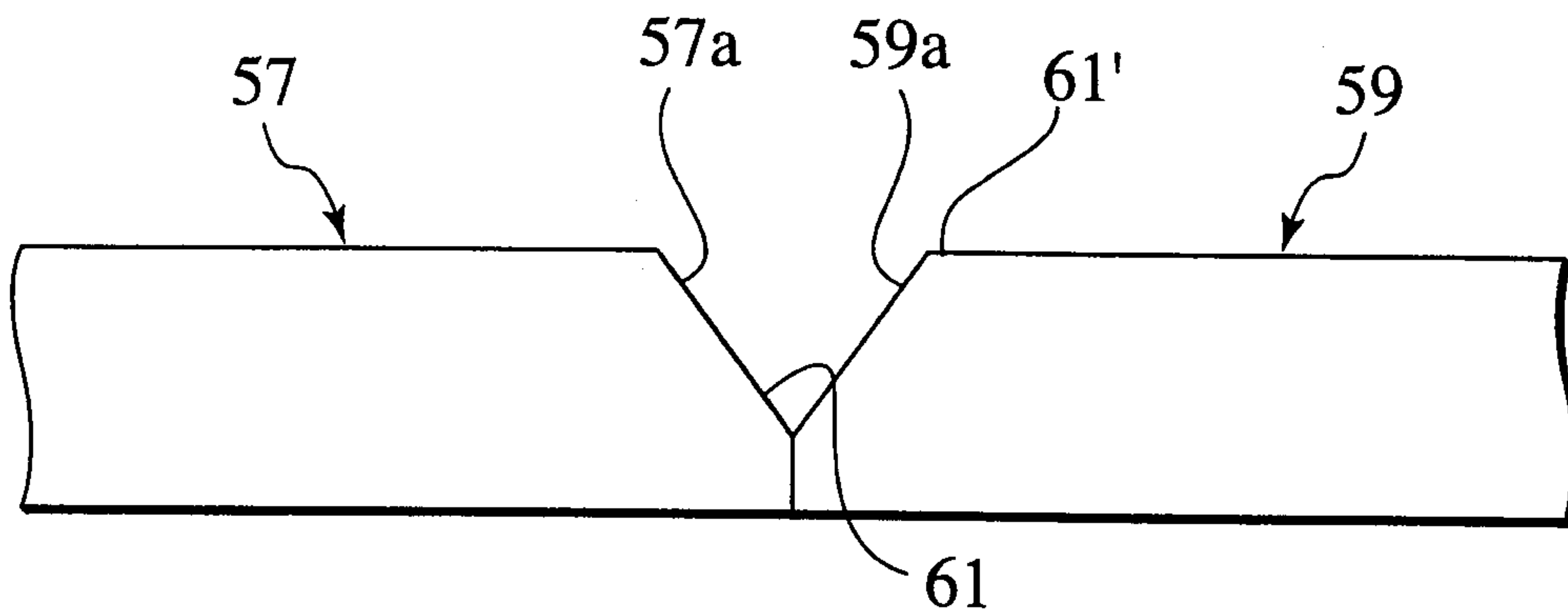

FIG.20

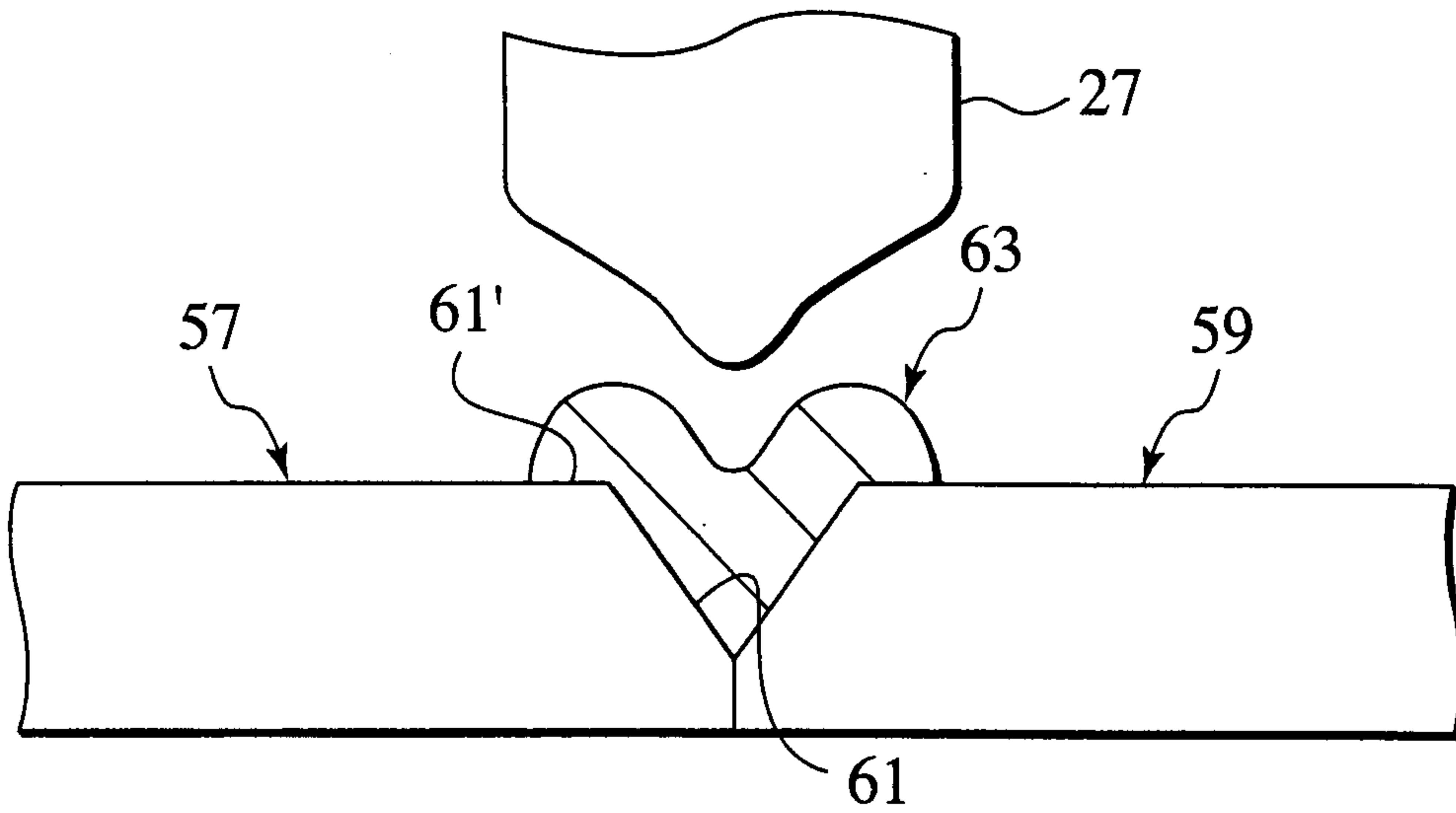

FIG.21

