

(19) World Intellectual Property Organization
International Bureau



(43) International Publication Date
3 May 2007 (03.05.2007)

PCT

(10) International Publication Number
WO 2007/050450 A2

- (51) **International Patent Classification:**
C10G 1/00 (2006.01) C10G 11/00 (2006.01)
C10G 1/02 (2006.01)
- (21) **International Application Number:**
PCT/US2006/040991
- (22) **International Filing Date:** 20 October 2006 (20.10.2006)
- (25) **Filing Language:** English
- (26) **Publication Language:** English
- (30) **Priority Data:**
60/729,763 24 October 2005 (24.10.2005) US
60/794,298 21 April 2006 (21.04.2006) US
- (71) **Applicant (for all designated States except US):** SHELL OIL COMPANY [US/US]; One Shell Plaza, P.O. Box 2463, Houston, Texas 77252-2463 (US).
- (72) **Inventors; and**
- (75) **Inventors/Applicants (for US only):** MO, Weijian [US/US]; 719 Winston Lane, Sugar Land, Texas 77479 (US). NAIR, Vijay [SG/US]; 21818 Moortown Circle, Katy, Texas 77450 (US). ROES, Augustinus, Wilhelmus, Maria [NL/US]; 5807 Santa Fe Springs Drive, Houston, Texas 77041 (US).
- (74) **Agent:** CHRISTENSEN, Del, S.; SHELL OIL COMPANY, One Shell Plaza, P.O. Box 2463, Houston, Texas 77252-2463 (US).

- (81) **Designated States (unless otherwise indicated, for every kind of national protection available):** AE, AG, AL, AM, AT, AU, AZ, BA, BB, BG, BR, BW, BY, BZ, CA, CH, CN, CO, CR, CU, CZ, DE, DK, DM, DZ, EC, EE, EG, ES, FI, GB, GD, GE, GH, GM, GT, HN, HR, HU, ID, IL, IN, IS, JP, KE, KG, KM, KN, KP, KR, KZ, LA, LC, LK, LR, LS, LT, LU, LV, LY, MA, MD, MG, MK, MN, MW, MX, MY, MZ, NA, NG, NI, NO, NZ, OM, PG, PH, PL, PT, RO, RS, RU, SC, SD, SE, SG, SK, SL, SM, SV, SY, TJ, TM, TN, TR, TT, TZ, UA, UG, US, UZ, VC, VN, ZA, ZM, ZW.
- (84) **Designated States (unless otherwise indicated, for every kind of regional protection available):** ARIPO (BW, GH, GM, KE, LS, MW, MZ, NA, SD, SL, SZ, TZ, UG, ZM, ZW), Eurasian (AM, AZ, BY, KG, KZ, MD, RU, TJ, TM), European (AT, BE, BG, CH, CY, CZ, DE, DK, EE, ES, FI, FR, GB, GR, HU, IE, IS, IT, LT, LU, LV, MC, NL, PL, PT, RO, SE, SI, SK, TR), OAPI (BF, BJ, CF, CG, CI, CM, GA, GN, GQ, GW, ML, MR, NE, SN, TD, TG).

Published:
— without international search report and to be republished upon receipt of that report

For two-letter codes and other abbreviations, refer to the "Guidance Notes on Codes and Abbreviations" appearing at the beginning of each regular issue of the PCT Gazette.

(54) **Title:** METHODS OF CRACKING A CRUDE PRODUCT TO PRODUCE ADDITIONAL CRUDE PRODUCTS

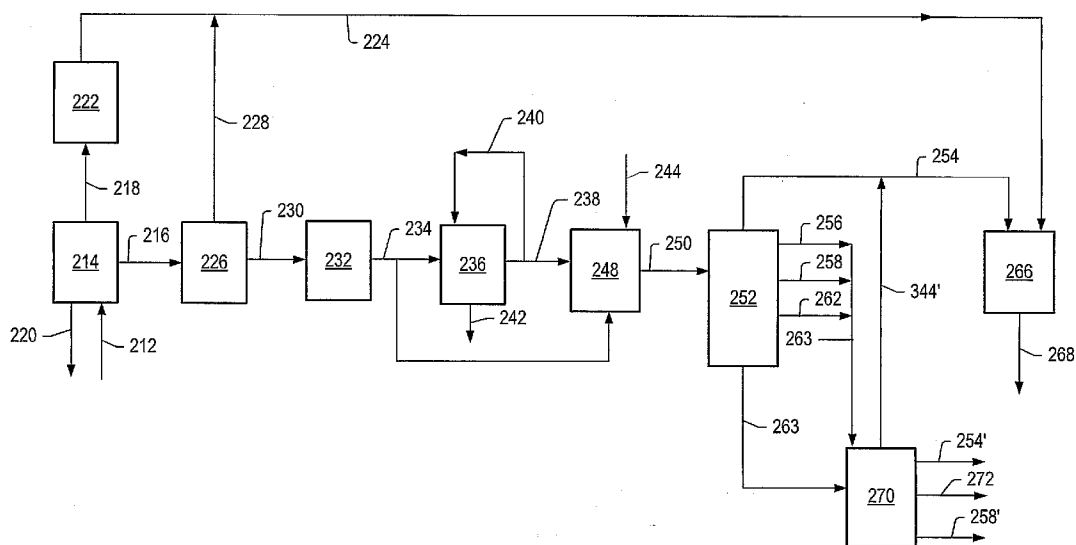

(57) **Abstract:** The invention provides methods for producing crude products that includes producing formation fluid from a sub-surface in situ heat treatment process; separating the formation fluid to produce a liquid stream and a first gas stream, fractionating the liquid stream to produce one or more crude products, and catalytically cracking the crude product having the boiling point above 343 °C to produce one or more additional crude products. The first gas stream may include olefins. At least one of the produced crude products has a boiling point above 343 °C and at least one of the additional crude products is a second gas stream. The first gas stream may include olefins. At least one of the crude products has a boiling point above 343 °C and/or least one of the additional crude products is a second gas stream.

WO 2007/050450 A2

**METHODS OF CRACKING A CRUDE PRODUCT TO PRODUCE
ADDITIONAL CRUDE PRODUCTS**

BACKGROUND

5 1. **Field of the Invention**

The present invention relates generally to methods and systems for production of hydrocarbons, hydrogen, and/or other products from various subsurface formations such as hydrocarbon containing formations.

2. **Description of Related Art**

10 Hydrocarbons obtained from subterranean formations are often used as energy resources, as feedstocks, and as consumer products. Concerns over depletion of available hydrocarbon resources and concerns over declining overall quality of produced hydrocarbons have led to development of processes for more efficient recovery, processing and/or use of available hydrocarbon resources. In situ processes may be used to remove hydrocarbon materials from subterranean formations. Chemical and/or physical properties
15 of hydrocarbon material in a subterranean formation may need to be changed to allow hydrocarbon material to be more easily removed from the subterranean formation. The chemical and physical changes may include in situ reactions that produce removable fluids, composition changes, solubility changes, density changes, phase changes, and/or viscosity changes of the hydrocarbon material in the formation. A fluid may be, but is not limited to, a gas, a liquid, an emulsion, a slurry, and/or a stream of solid particles that has flow
20 characteristics similar to liquid flow.

Formation fluids obtained from subterranean formations using an in situ heat treatment process may be sold and/or processed to produce commercial products. The formation fluids produced by an in situ heat treatment process may have different properties and/or compositions than formation fluids obtained through
25 conventional production processes. Formation fluids obtained from subterranean formations using an in situ heat treatment process may not meet industry standards for transportation and/or commercial use. Thus, there is a need for improved methods and systems for treatment of formation fluids obtained from various hydrocarbon containing formations.

SUMMARY

30 Embodiments described herein generally relate to methods for treating formation fluids produced from a subsurface formation.

In some embodiments, the invention provides producing formation fluid from a subsurface in situ pyrolysis heat treatment process; separating the formation fluid to produce a liquid stream and a first gas stream, wherein the first gas stream comprises olefins; fractionating the liquid stream to produce one or more
35 crude products, wherein at least one of the crude products has a boiling range distribution from 38 °C and 343 °C; and catalytically cracking the crude product having the boiling range distribution from 38 °C and 343 °C to produce one or more additional crude products, wherein at least one of the additional crude products is a second gas stream, and the gas stream has a boiling point of at most 38 °C, wherein boiling range distributions are determined by ASTM Method D5307.

In some embodiments, the invention provides a method for producing one or more crude products, that includes: producing formation fluid from a subsurface in situ heat treatment process; separating the formation fluid to produce a liquid stream; catalytically cracking the liquid stream in a first catalytic cracking system by contacting the liquid stream with a catalytic cracking catalyst to produce a crude product stream and a spent catalytic cracking catalyst; regenerating the spent catalytic cracking catalyst to produce a regenerated cracking catalyst; catalytically cracking a gasoline hydrocarbons stream in a second catalytic cracking system by contacting the gasoline hydrocarbons stream with the regenerated catalytic cracking catalyst to produce a crude olefin stream comprising hydrocarbons having a carbon number of at least 2 and a used regenerated cracking catalyst; and separating olefins from the crude olefin stream, wherein the olefins have a carbon number from 2 to 5; and providing the used regenerated cracking catalyst from the second catalytic cracking system to the first catalytic cracking system.

In further embodiments, features from specific embodiments may be combined with features from other embodiments. For example, features from one embodiment may be combined with features from any of the other embodiments.

In further embodiments, treating a subsurface formation is performed using any of the methods, systems, or heaters described herein.

In further embodiments, additional features may be added to the specific embodiments described herein.

BRIEF DESCRIPTION OF THE DRAWINGS

Advantages of the present invention may become apparent to those skilled in the art with the benefit of the following detailed description and upon reference to the accompanying drawings in which:

FIG. 1 shows a schematic view of an embodiment of a portion of an in situ heat treatment system for treating a hydrocarbon containing formation.

FIG. 2 depicts a schematic representation of an embodiment of a system for treating the mixture produced from the in situ heat treatment process.

FIG. 3 depicts a schematic representation of an embodiment of a system for treating a liquid stream produced from an in situ heat treatment process.

While the invention is susceptible to various modifications and alternative forms, specific embodiments thereof are shown by way of example in the drawings and may herein be described in detail. The drawings may not be to scale. It should be understood, however, that the drawings and detailed description thereto are not intended to limit the invention to the particular form disclosed, but on the contrary, the intention is to cover all modifications, equivalents and alternatives falling within the spirit and scope of the present invention as defined by the appended claims.

DETAILED DESCRIPTION

The following description generally relates to systems and methods for treating hydrocarbons in the formations. Such formations may be treated to yield hydrocarbon products, hydrogen, and other products.

The following description generally relates to systems and methods for treating formation fluid produced from a hydrocarbon containing formation using an in situ heat treatment process. Hydrocarbon containing formations may be treated to yield hydrocarbon products, hydrogen, methane, and other products.

“Hydrocarbons” are generally defined as molecules formed primarily by carbon and hydrogen atoms. Hydrocarbons may also include other elements such as, but not limited to, halogens, metallic elements, nitrogen, oxygen, and/or sulfur. Hydrocarbons may be, but are not limited to, kerogen, bitumen, pyrobitumen, oils, natural mineral waxes, and asphaltites. Hydrocarbons may be located in or adjacent to mineral matrices in the earth. Matrices may include, but are not limited to, sedimentary rock, sands, silicilytes, carbonates, diatomites, and other porous media. “Hydrocarbon fluids” are fluids that include hydrocarbons. Hydrocarbon fluids may include, entrain, or be entrained in non-hydrocarbon fluids such as hydrogen, nitrogen, carbon monoxide, carbon dioxide, hydrogen sulfide, water, and ammonia.

A “formation” includes one or more hydrocarbon containing layers, one or more non-hydrocarbon layers, an overburden, and/or an underburden. The “overburden” and/or the “underburden” include one or more different types of impermeable materials. For example, overburden and/or underburden may include rock, shale, mudstone, or wet/tight carbonate. In some embodiments of in situ heat treatment processes, the overburden and/or the underburden may include a hydrocarbon containing layer or hydrocarbon containing layers that are relatively impermeable and are not subjected to temperatures during in situ heat treatment processing that result in significant characteristic changes of the hydrocarbon containing layers of the overburden and/or the underburden. For example, the underburden may contain shale or mudstone, but the underburden is not allowed to heat to pyrolysis temperatures during the in situ heat treatment process. In some cases, the overburden and/or the underburden may be somewhat permeable.

“Formation fluids” refer to fluids present in a formation and may include pyrolyzation fluid, synthesis gas, mobilized fluid, visbroken fluid, and water (steam). Formation fluids may include hydrocarbon fluids as well as non-hydrocarbon fluids. “Mobilized fluid” refers to fluid in a hydrocarbon containing formation that is able to flow as a result of thermal treatment of the formation. “Visbroken fluid” refers to fluid that has a viscosity that has been reduced as a result of heat treatment of the formation.

“Produced fluids” refer to formation fluids removed from the formation.

An “in situ conversion process” refers to a process of heating a hydrocarbon containing formation from heat sources to raise the temperature of at least a portion of the formation above a pyrolysis temperature so that pyrolyzation fluid is produced in the formation.

“Carbon number” refers to the number of carbon atoms in a molecule. A hydrocarbon fluid may include various hydrocarbons with different carbon numbers. The hydrocarbon fluid may be described by a carbon number distribution. Carbon numbers and/or carbon number distributions may be determined by true boiling point distribution and/or gas-liquid chromatography.

A “heat source” is any system for providing heat to at least a portion of a formation substantially by conductive and/or radiative heat transfer. For example, a heat source may include electric heaters such as an insulated conductor, an elongated member, and/or a conductor disposed in a conduit. A heat source may also include systems that generate heat by burning a fuel external to or in a formation. The systems may be surface burners, downhole gas burners, flameless distributed combustors, and natural distributed combustors. In some embodiments, heat provided to or generated in one or more heat sources may be supplied by other sources of energy. The other sources of energy may directly heat a formation, or the energy may be applied to a transfer medium that directly or indirectly heats the formation. It is to be understood that one or more heat sources that are applying heat to a formation may use different sources of energy. Thus, for example,

for a given formation some heat sources may supply heat from electric resistance heaters, some heat sources may provide heat from combustion, and some heat sources may provide heat from one or more other energy sources (for example, chemical reactions, solar energy, wind energy, biomass, or other sources of renewable energy). A chemical reaction may include an exothermic reaction (for example, an oxidation reaction). A heat source may also include a heater that provides heat to a zone proximate and/or surrounding a heating location such as a heater well.

A "heater" is any system or heat source for generating heat in a well or a near wellbore region. Heaters may be, but are not limited to, electric heaters, burners, combustors that react with material in or produced from a formation, and/or combinations thereof.

An "in situ heat treatment process" refers to a process of heating a hydrocarbon containing formation with heat sources to raise the temperature of at least a portion of the formation above a temperature that results in mobilized fluid, visbreaking, and/or pyrolysis of hydrocarbon containing material so that mobilized fluids, visbroken fluids, and/or pyrolyzation fluids are produced in the formation.

The term "wellbore" refers to a hole in a formation made by drilling or insertion of a conduit into the formation. A wellbore may have a substantially circular cross section, or another cross-sectional shape. As used herein, the terms "well" and "opening," when referring to an opening in the formation may be used interchangeably with the term "wellbore."

"Pyrolysis" is the breaking of chemical bonds due to the application of heat. For example, pyrolysis may include transforming a compound into one or more other substances by heat alone. Heat may be transferred to a section of the formation to cause pyrolysis. In some formations, portions of the formation and/or other materials in the formation may promote pyrolysis through catalytic activity.

"Pyrolyzation fluids" or "pyrolysis products" refers to fluid produced substantially during pyrolysis of hydrocarbons. Fluid produced by pyrolysis reactions may mix with other fluids in a formation. The mixture would be considered pyrolyzation fluid or pyrolyzation product. As used herein, "pyrolysis zone" refers to a volume of a formation (for example, a relatively permeable formation such as a tar sands formation) that is reacted or reacting to form a pyrolyzation fluid.

"Cracking" refers to a process involving decomposition and molecular recombination of organic compounds to produce a greater number of molecules than were initially present. In cracking, a series of reactions take place accompanied by a transfer of hydrogen atoms between molecules. For example, naphtha may undergo a thermal cracking reaction to form ethene and H₂.

"Visbreaking" refers to the untangling of molecules in fluid during heat treatment and/or to the breaking of large molecules into smaller molecules during heat treatment, which results in a reduction of the viscosity of the fluid.

"Condensable hydrocarbons" are hydrocarbons that condense at 25 °C and one atmosphere absolute pressure. Condensable hydrocarbons may include a mixture of hydrocarbons having carbon numbers greater than 4. "Non-condensable hydrocarbons" are hydrocarbons that do not condense at 25 °C and one atmosphere absolute pressure. Non-condensable hydrocarbons may include hydrocarbons having carbon numbers less than 5.

"Clogging" refers to impeding and/or inhibiting flow of one or more compositions through a process vessel or a conduit.

“Olefins” are molecules that include unsaturated hydrocarbons having one or more non-aromatic carbon-carbon double bonds.

“Gasoline hydrocarbons” refer to hydrocarbons having a boiling point range from 32 °C (90 °F) to about 204 °C (400 °F). Gasoline hydrocarbons include, but are not limited to, straight run gasoline, naphtha, fluidized or thermally catalytically cracked gasoline, VB gasoline, and coker gasoline. Gasoline hydrocarbons content is determined by ASTM Method D2887.

“Naphtha” refers to hydrocarbon components with a boiling range distribution between 38 °C and 200 °C at 0.101 MPa. Naphtha content is determined by American Standard Testing and Materials (ASTM) Method D5307.

“Kerosene” refers to hydrocarbons with a boiling range distribution between 204 °C and 260 °C at 0.101 MPa. Kerosene content is determined by ASTM Method D2887.

“Diesel” refers to hydrocarbons with a boiling range distribution between 260 °C and 343 °C (500-650 °F) at 0.101 MPa. Diesel content is determined by ASTM Method D2887.

“VGO” or “vacuum gas oil” refers to hydrocarbons with a boiling range distribution between 343 °C and 538 °C at 0.101 MPa. VGO content is determined by ASTM Method D5307.

“Upgrade” refers to increasing the quality of hydrocarbons. For example, upgrading heavy hydrocarbons may result in an increase in the API gravity of the heavy hydrocarbons.

“API gravity” refers to API gravity at 15.5 °C (60 °F). API gravity is as determined by ASTM Method D6822.

“Periodic Table” refers to the Periodic Table as specified by the International Union of Pure and Applied Chemistry (IUPAC), October 2005.

“Column X metal” or “Column X metals” refer to one or more metals of Column X of the Periodic Table and/or one or more compounds of one or more metals of Column X of the Periodic Table, in which X corresponds to a column number (for example, 1-12) of the Periodic Table. For example, “Column 6 metals” refer to metals from Column 6 of the Periodic Table and/or compounds of one or more metals from Column 6 of the Periodic Table.

“Column X element” or “Column X elements” refer to one or more elements of Column X of the Periodic Table, and/or one or more compounds of one or more elements of Column X of the Periodic Table, in which X corresponds to a column number (for example, 13-18) of the Periodic Table. For example, “Column 15 elements” refer to elements from Column 15 of the Periodic Table and/or compounds of one or more elements from Column 15 of the Periodic Table.

In the scope of this application, weight of a metal from the Periodic Table, weight of a compound of a metal from the Periodic Table, weight of an element from the Periodic Table, or weight of a compound of an element from the Periodic Table is calculated as the weight of metal or the weight of element. For example, if 0.1 grams of MoO₃ is used per gram of catalyst, the calculated weight of the molybdenum metal in the catalyst is 0.067 grams per gram of catalyst.

“Upgrade” refers to increasing the quality of hydrocarbons. For example, upgrading heavy hydrocarbons may result in an increase in the API gravity of the heavy hydrocarbons.

“Cycle oil” refers to a mixture of light cycle oil and heavy cycle oil. “Light cycle oil” refers to hydrocarbons having a boiling range distribution between 430 °F (221 °C) and 650 °F (343 °C) that are

produced from a fluidized catalytic cracking system. Light cycle oil content is determined by ASTM Method D5307. "Heavy cycle oil" refers to hydrocarbons having a boiling range distribution between 650 °F (343 °C) and 800 °F (427 °C) that are produced from a fluidized catalytic cracking system. Heavy cycle oil content is determined by ASTM Method D5307.

5 "Octane Number" refers to a calculated numerical representation of the antiknock properties of a motor fuel compared to a standard reference fuel. A calculated octane number is determined by ASTM Method D6730.

"Cenospheres" refers to hollow particulate that are formed in thermal processes at high temperatures when molten components are blown up like balloons by the volatilization of organic components.

10

"Physical stability" refers the ability of a formation fluid to not exhibit phase separate or flocculation during transportation of the fluid. Physical stability is determined by ASTM Method D7060.

"Chemically stability" refers to the ability of a formation fluid to be transported without components in the formation fluid reacting to form polymers and/or compositions that plug pipelines, valves, and/or vessels.

15

FIG. 1 depicts a schematic view of an embodiment of a portion of the in situ heat treatment system for treating the hydrocarbon containing formation. The in situ heat treatment system may include barrier wells 200. Barrier wells are used to form a barrier around a treatment area. The barrier inhibits fluid flow into and/or out of the treatment area. Barrier wells include, but are not limited to, dewatering wells, vacuum wells, capture wells, injection wells, grout wells, freeze wells, or combinations thereof. In some embodiments, barrier wells 200 are dewatering wells. Dewatering wells may remove liquid water and/or inhibit liquid water from entering a portion of the formation to be heated, or to the formation being heated. In the embodiment depicted in FIG. 1, the barrier wells 200 are shown extending only along one side of heat sources 202, but the barrier wells typically encircle all heat sources 202 used, or to be used, to heat a treatment area of the formation.

20
25

Heat sources 202 are placed in at least a portion of the formation. Heat sources 202 may include heaters such as insulated conductors, conductor-in-conduit heaters, surface burners, flameless distributed combustors, and/or natural distributed combustors. Heat sources 202 may also include other types of heaters. Heat sources 202 provide heat to at least a portion of the formation to heat hydrocarbons in the formation. Energy may be supplied to heat sources 202 through supply lines 204. Supply lines 204 may be structurally different depending on the type of heat source or heat sources used to heat the formation. Supply lines 204 for heat sources may transmit electricity for electric heaters, may transport fuel for combustors, or may transport heat exchange fluid that is circulated in the formation.

30

When the formation is heated, the heat input into the formation may cause expansion of the formation and geomechanical motion. Computer simulations may model formation response to heating. The computer simulations may be used to develop a pattern and time sequence for activating heat sources in the formation so that geomechanical motion of the formation does not adversely affect the functionality of heat sources, production wells, and other equipment in the formation.

35

Heating the formation may cause an increase in permeability and/or porosity of the formation. Increases in permeability and/or porosity may result from a reduction of mass in the formation due to

40

vaporization and removal of water, removal of hydrocarbons, and/or creation of fractures. Fluid may flow more easily in the heated portion of the formation because of the increased permeability and/or porosity of the formation. Fluid in the heated portion of the formation may move a considerable distance through the formation because of the increased permeability and/or porosity. The considerable distance may be over
5 1000 m depending on various factors, such as permeability of the formation, properties of the fluid, temperature of the formation, and pressure gradient allowing movement of the fluid. The ability of fluid to travel considerable distance in the formation allows production wells 206 to be spaced relatively far apart in the formation.

Production wells 206 are used to remove formation fluid from the formation. In some
10 embodiments, production well 206 includes a heat source. The heat source in the production well may heat one or more portions of the formation at or near the production well. In some in situ heat treatment process embodiments, the amount of heat supplied to the formation from the production well per meter of the production well is less than the amount of heat applied to the formation from a heat source that heats the formation per meter of the heat source. Heat applied to the formation from the production well may increase
15 formation permeability adjacent to the production well by vaporizing and removing liquid phase fluid adjacent to the production well and/or by increasing the permeability of the formation adjacent to the production well by formation of macro and/or micro fractures.

More than one heat source may be positioned in the production well. A heat source in a lower portion of the production well may be turned off when superposition of heat from adjacent heat sources heats
20 the formation sufficiently to counteract benefits provided by heating the formation with the production well. In some embodiments, the heat source in an upper portion of the production well may remain on after the heat source in the lower portion of the production well is deactivated. The heat source in the upper portion of the well may inhibit condensation and reflux of formation fluid.

In some embodiments, the heat source in production well 206 allows for vapor phase removal of
25 formation fluids from the formation. Providing heating at or through the production well may: (1) inhibit condensation and/or refluxing of production fluid when such production fluid is moving in the production well proximate the overburden, (2) increase heat input into the formation, (3) increase production rate from the production well as compared to a production well without a heat source, (4) inhibit condensation of high carbon number compounds (C6 and above) in the production well, and/or (5) increase formation
30 permeability at or proximate the production well.

Subsurface pressure in the formation may correspond to the fluid pressure generated in the formation. As temperatures in the heated portion of the formation increase, the pressure in the heated portion may increase as a result of increased fluid generation and vaporization of water. Controlling rate of fluid removal from the formation may allow for control of pressure in the formation. Pressure in the
35 formation may be determined at a number of different locations, such as near or at production wells, near or at heat sources, or at monitor wells.

In some hydrocarbon containing formations, production of hydrocarbons from the formation is inhibited until at least some hydrocarbons in the formation have been pyrolyzed. Formation fluid may be produced from the formation when the formation fluid is of a selected quality. In some embodiments, the
40 selected quality includes an API gravity of at least about 20°, 30°, or 40°. Inhibiting production until at least

some hydrocarbons are pyrolyzed may increase conversion of heavy hydrocarbons to light hydrocarbons. Inhibiting initial production may minimize the production of heavy hydrocarbons from the formation. Production of substantial amounts of heavy hydrocarbons may require expensive equipment and/or reduce the life of production equipment.

5 In some hydrocarbon containing formations, hydrocarbons in the formation may be heated to pyrolysis temperatures before substantial permeability has been generated in the heated portion of the formation. An initial lack of permeability may inhibit the transport of generated fluids to production wells 206. During initial heating, fluid pressure in the formation may increase proximate heat sources 202. The increased fluid pressure may be released, monitored, altered, and/or controlled through one or more heat
10 sources 202. For example, selected heat sources 202 or separate pressure relief wells may include pressure relief valves that allow for removal of some fluid from the formation.-

In some embodiments, pressure generated by expansion of pyrolysis fluids or other fluids generated in the formation may be allowed to increase although an open path to production wells 206 or any other pressure sink may not yet exist in the formation. The fluid pressure may be allowed to increase towards a
15 lithostatic pressure. Fractures in the hydrocarbon containing formation may form when the fluid approaches the lithostatic pressure. For example, fractures may form from heat sources 202 to production wells 206 in the heated portion of the formation. The generation of fractures in the heated portion may relieve some of the pressure in the portion. Pressure in the formation may have to be maintained below a selected pressure to inhibit unwanted production, fracturing of the overburden or underburden, and/or coking of hydrocarbons
20 in the formation.

After pyrolysis temperatures are reached and production from the formation is allowed, pressure in the formation may be varied to alter and/or control a composition of formation fluid produced, to control a percentage of condensable fluid as compared to non-condensable fluid in the formation fluid, and/or to control an API gravity of formation fluid being produced. For example, decreasing pressure may result in
25 production of a larger condensable fluid component. The condensable fluid component may contain a larger percentage of olefins.

In some in situ heat treatment process embodiments, pressure in the formation may be maintained high enough to promote production of formation fluid with an API gravity of greater than 20°. Maintaining increased pressure in the formation may inhibit formation subsidence during in situ heat treatment.
30 Maintaining increased pressure may facilitate vapor phase production of fluids from the formation. Vapor phase production may allow for a reduction in size of collection conduits used to transport fluids produced from the formation. Maintaining increased pressure may reduce or eliminate the need to compress formation fluids at the surface to transport the fluids in collection conduits to treatment facilities.

Maintaining increased pressure in a heated portion of the formation may surprisingly allow for
35 production of large quantities of hydrocarbons of increased quality and of relatively low molecular weight. Pressure may be maintained so that formation fluid produced has a minimal amount of compounds above a selected carbon number. The selected carbon number may be at most 25, at most 20, at most 12, or at most 8. Some high carbon number compounds may be entrained in vapor in the formation and may be removed from the formation with the vapor. Maintaining increased pressure in the formation may inhibit entrainment
40 of high carbon number compounds and/or multi-ring hydrocarbon compounds in the vapor. High carbon

number compounds and/or multi-ring hydrocarbon compounds may remain in a liquid phase in the formation for significant time periods. The significant time periods may provide sufficient time for the compounds to pyrolyze to form lower carbon number compounds.

5 Generation of relatively low molecular weight hydrocarbons is believed to be due, in part, to autogenous generation and reaction of hydrogen in a portion of the hydrocarbon containing formation. For example, maintaining an increased pressure may force hydrogen generated during pyrolysis into the liquid phase within the formation. Heating the portion to a temperature in a pyrolysis temperature range may pyrolyze hydrocarbons in the formation to generate liquid phase pyrolyzation fluids. The generated liquid phase pyrolyzation fluids components may include double bonds and/or radicals. Hydrogen (H₂) in the
10 liquid phase may reduce double bonds of the generated pyrolyzation fluids, thereby reducing a potential for polymerization or formation of long chain compounds from the generated pyrolyzation fluids. In addition, H₂ may also neutralize radicals in the generated pyrolyzation fluids. Therefore, H₂ in the liquid phase may inhibit the generated pyrolyzation fluids from reacting with each other and/or with other compounds in the formation.

15 Formation fluid produced from production wells 206 may be transported through collection piping 208 to treatment facilities 210. Formation fluids may also be produced from heat sources 202. For example, fluid may be produced from heat sources 202 to control pressure in the formation adjacent to the heat sources. Fluid produced from heat sources 202 may be transported through tubing or piping to collection piping 208 or the produced fluid may be transported through tubing or piping directly to treatment facilities
20 210. Treatment facilities 210 may include separation units, reaction units, upgrading units, fuel cells, turbines, storage vessels, and/or other systems and units for processing produced formation fluids. The treatment facilities may form transportation fuel from at least a portion of the hydrocarbons produced from the formation.

25 In some embodiments, formation fluid produced from the in situ heat treatment process is sent to a separator to split the formation fluid into one or more in situ heat treatment process liquid streams and/or one or more in situ heat treatment process gas streams. The liquid streams and the gas streams may be further treated to yield desired products.

30 Heating a portion of the subsurface formation may cause the mineral structure of the formation to change and form particles. The particles may be dispersed and/or become partially dissolved in the formation fluid. The particles may include metals and/or compounds of metals from Columns 1-2 and Columns 4-13 of the Periodic Table (for example, aluminum, silicon, magnesium, calcium, potassium sodium, beryllium, lithium, chromium, magnesium, copper, zirconium, and so forth). In certain
35 embodiments, the particles include cenospheres. In some embodiments, the particles are coated, for example, with hydrocarbons of the formation fluid. In certain embodiments, the particles include zeolites.

A concentration of particles in formation fluid may range from 1 ppm to 3000 ppm, from 50 ppm to 2000 ppm, or from 100 ppm to 1000 ppm. The size of particles may range from 0.5 micrometers to 200 micrometers, from 5 micrometers to 150 micrometers, from 10 micrometers to 100 micrometers, or 20 micrometers to 50 micrometers.

40 In certain embodiments, formation fluid may include a distribution of particles. The distribution of particles may be, but is not limited to, a trimodal or a bimodal distribution. For example, a trimodal

distribution of particles may include from 1 ppm to 50 ppm of particles with a size of 5 micrometers to 10 micrometers, from 2 ppm to 2000 ppm of particles with a size of 50 micrometers to 80 micrometers, and from 1 ppm to 100 ppm with a size of between 100 micrometers and 200 micrometers. A bimodal distribution of particles may include from 1 ppm to 60 ppm of particles with a size of between 50
5 micrometers and 60 micrometers and from 2 ppm to 2000 ppm of particles with a size between 100 micrometers and 200 micrometers.

In some embodiments, the particles may contact the formation fluid and catalyze formation of compounds having a carbon number of at most 25, at most 20, at most 12, or at most 8. In certain
10 embodiments, zeolitic particles may assist in the oxidation and/or reduction of formation fluids to produce compounds not generally found in fluids produced using conventional production methods. Contact of formation fluid with hydrogen in the presence of zeolitic particles may catalyze reduction of double bond compounds in the formation fluid.

In some embodiments, all or a portion of the particles in the produced fluid may be removed from the produced fluid. The particles may be removed by using a centrifuge, by washing, by acid washing, by
15 filtration, by electrostatic precipitation, by froth flotation, and/or by another type of separation process.

Formation fluid produced from the in situ heat treatment process may be sent to the separator to split the stream into the in situ heat treatment process liquid stream and an in situ heat treatment process gas stream. The liquid stream and the gas stream may be further treated to yield desired products. When the liquid stream is treated using generally known conditions to produce commercial products, processing
20 equipment may be adversely affected. For example, the processing equipment may clog. Examples of processes to produce commercial products include, but are not limited to, alkylation, distillation, catalytic reforming hydrocracking, hydrotreating, hydrogenation, hydrodesulfurization, catalytic cracking, delayed coking, gasification, or combinations thereof. Processes to produce commercial products are described in "Refining Processes 2000," Hydrocarbon Processing, Gulf Publishing Co., pp. 87-142, which is incorporated
25 by reference herein. Examples of commercial products include, but are not limited to, diesel, gasoline, hydrocarbon gases, jet fuel, kerosene, naphtha, vacuum gas oil ("VGO"), or mixtures thereof.

Process equipment may become clogged or fouled by compositions in the in situ heat treatment process liquid. Clogging compositions may include, but are not limited to, hydrocarbons and/or solids produced from the in situ heat treatment process. Compositions that cause clogging may be formed during
30 heating of the in situ heat treatment process liquid. The compositions may adhere to parts of the equipment and inhibit the flow of the liquid stream through processing units.

Solids that cause clogging may include, but are not limited to, organometallic compounds, inorganic compounds, minerals, mineral compounds, cenospheres, coke, semi-soot, and/or mixtures thereof. The solids may have a particle size such that conventional filtration may not remove the solids from the
35 liquid stream. Hydrocarbons that cause clogging may include, but are not limited to, hydrocarbons that contain heteroatoms, aromatic hydrocarbons, cyclic hydrocarbons, cyclic di-olefins, and/or acyclic di-olefins. In some embodiments, solids and/or hydrocarbons present in the in situ heat treatment process liquid that cause clogging are partially soluble or insoluble in the situ heat treatment process liquid. In some embodiments, conventional filtration of the liquid stream prior to or during heating is insufficient and/or
40 ineffective for removal of all or some of the compositions that clog process equipment.

In some embodiments, clogging compositions are at least partially removed from the liquid stream by washing and/or desalting the liquid stream. In some embodiments, clogging of process equipment is inhibited by filtering at least a portion of the liquid stream through a nanofiltration system. In some
5 embodiments, clogging of process equipment is inhibited by hydrotreating at least a portion of the liquid stream. In some embodiments, at least a portion the liquid stream is nanofiltered and then hydrotreated to remove composition that may clog and/or foul process equipment. The hydrotreated and/or nanofiltered liquid stream may be further processed to produce commercial products. In some embodiments, anti-fouling additives are added to the liquid stream to inhibit clogging of process equipment. Anti-fouling additives are described in U.S. Patent Nos. 5,648,305 to Mansfield et al.; 5,282,957 to Wright et al.; 5,173,213 to Miller et
10 al.; 4,840,720 to Reid; 4,810,397 to Dvoracek; and 4,551,226 to Fern, all of which are incorporated by reference herein. Examples of commercially available additives include, but are not limited to, Chimec RO 303 Chimec RO 304, Chimec RO 305, Chimec RO 306, Chimec RO 307, Chimec RO 308, (available from Chimec, Rome, Italy), GE-Betz Thermal Flow 7R29 GE-Betz ProChem 3F28, Ge Betz ProChem 3F18 (available from GE Water and Process Technologies, Trevose, PA, U.S.A.).

FIG. 2 depicts a schematic representation of an embodiment of a system for producing crude
15 products and/or commercial products from the in situ heat treatment process liquid stream and/or the in situ heat treatment process gas stream. Formation fluid 212 enters fluid separation unit 214 and is separated into in situ heat treatment process liquid stream 216, in situ heat treatment process gas 218 and aqueous stream 220. In some embodiments, fluid separation unit 214 includes a quench zone. As produced formation fluid enters the quench zone, quenching fluid such as water, nonpotable water and/or other components may be
20 added to the formation fluid to quench and/or cool the formation fluid to a temperature suitable for handling in downstream processing equipment. Quenching the formation fluid may inhibit formation of compounds that contribute to physical and/or chemical instability of the fluid (for example, inhibit formation of compounds that may precipitate from solution, contribute to corrosion, and/or fouling of downstream
25 equipment and/or piping). The quenching fluid may be introduced into the formation fluid as a spray and/or a liquid stream. In some embodiments, the formation fluid is introduced into the quenching fluid. In some embodiments, the formation fluid is cooled by passing the fluid through a heat exchanger to remove some heat from the formation fluid. The quench fluid may be added to the cooled formation fluid when the temperature of the formation fluid is near or at the dew point of the quench fluid. Quenching the formation
30 fluid near or at the dew point of the quench fluid may enhance solubilization of salts that may cause chemical and/or physical instability of the quenched fluid (for example, ammonium salts). In some embodiments, an amount of water used in the quench is minimal so that salts of inorganic compounds and/or other components do not separate from the mixture. In separation unit 214 at least a portion of the quench fluid may be separated from the quench mixture and recycled to the quench zone with a minimal amount of
35 treatment. Heat produced from the quench may be captured and used in other facilities. In some embodiments, vapor may be produced during the quench. The produced vapor may be sent to gas separation unit 222 and/or sent to other facilities for processing.

In situ heat treatment process gas 218 may enter gas separation unit 222 to separate gas hydrocarbon stream 224 from the in situ heat treatment process gas. The gas separation unit is, in some

embodiments, a rectified adsorption and high pressure fractionation unit. Gas hydrocarbon stream 224 includes hydrocarbons having a carbon number of at least 3.

In situ heat treatment process liquid stream 216 enters liquid separation unit 226. In some embodiments, liquid separation unit 226 is not necessary. In liquid separation unit 226, separation of in situ
5 heat treatment process liquid stream 216 produces gas hydrocarbon stream 228 and salty process liquid stream 230. Gas hydrocarbon stream 228 may include hydrocarbons having a carbon number of at most 5. A portion of gas hydrocarbon stream 228 may be combined with gas hydrocarbon stream 224. Salty process liquid stream 230 may be processed through desalting unit 232 to form liquid stream 234. Desalting unit 232 removes mineral salts and/or water from salty process liquid stream 230 using known desalting and
10 water removal methods. In certain embodiments, desalting unit 232 is upstream of liquid separation unit 226.

Liquid stream 234 includes, but is not limited to, hydrocarbons having a carbon number of at least 5 and/or hydrocarbon containing heteroatoms (for example, hydrocarbons containing nitrogen, oxygen, sulfur, and phosphorus). Liquid stream 234 may include at least 0.001 g, at least 0.005 g, or at least 0.01 g of
15 hydrocarbons with a boiling range distribution between 95 °C and 200 °C at 0.101 MPa; at least 0.01 g, at least 0.005 g, or at least 0.001 g of hydrocarbons with a boiling range distribution between 200 °C and 300 °C at 0.101 MPa; at least 0.001 g, at least 0.005 g, or at least 0.01 g of hydrocarbons with a boiling range distribution between 300 °C and 400 °C at 0.101 MPa; and at least 0.001 g, at least 0.005 g, or at least 0.01 g of hydrocarbons with a boiling range distribution between 400 °C and 650 °C at 0.101 MPa. In some
20 embodiments, liquid stream 234 contains at most 10% by weight water, at most 5% by weight water, at most 1% by weight water, or at most 0.1% by weight water.

After exiting desalting unit 232, liquid stream 234 enters filtration system 236. In some embodiments, filtration system 236 is connected to the outlet of the desalting unit. Filtration system 236 separates at least a portion of the clogging compounds from liquid stream 234. In some embodiments,
25 filtration system 236 is skid mounted. Skid mounting filtration system 236 may allow the filtration system to be moved from one processing unit to another. In some embodiments, filtration system 236 includes one or more membrane separators, for example, one or more nanofiltration membranes or one or more reverse osmosis membranes.

The membrane may be a ceramic membrane and/or a polymeric membrane. The ceramic
30 membrane may be a ceramic membrane having a molecular weight cut off of at most 2000 Daltons (Da), at most 1000 Da, or at most 500 Da. Ceramic membranes do not have to swell in order to work under optimal conditions to remove the desired materials from a substrate (e.g., clogging compositions from the liquid stream). In addition, ceramic membranes may be used at elevated temperatures. Examples of ceramic membranes include, but are not limited to, mesoporous titania, mesoporous gamma-alumina, mesoporous
35 zirconia, mesoporous silica, and combinations thereof.

The polymeric membrane includes a top layer made of a dense membrane and a base layer (support) made of a porous membrane. The polymeric membrane may be arranged to allow the liquid stream (permeate) to flow first through the dense membrane top layer and then through the base layer so that the pressure difference over the membrane pushes the top layer onto the base layer. The polymeric

membrane is organophilic or hydrophobic membrane so that water present in the liquid stream is retained or substantially retained in the retentate.

The dense membrane layer may separate at least a portion of or substantially all of the clogging compositions from liquid stream 234. In some embodiments, the dense polymeric membrane has properties such that liquid stream 234 passes through the membrane by dissolving in and diffusing through its structure. At least a portion of the clogging particles may not dissolve and/or diffuse through the dense membrane, thus they are removed. The clogging particles may not dissolve and/or diffuse through the dense membrane because of the complex structure of the clogging particles and/or their high molecular weight. The dense membrane layer may include a cross-linked structure as described in WO 96/27430 to Schmidt et al, which is incorporated by reference herein. A thickness of the dense membrane layer may range from a 1 micrometer to 15 micrometers, from 2 micrometers to 10 micrometers, or from 3 micrometers to 5 micrometers.

The dense membrane may be made from polysiloxane, poly-di-methyl siloxane, poly-octyl-methyl siloxane, polyimide, polyamide, poly-tri-methyl silyl propyne, or mixtures thereof. Porous base layers may be made of materials that provide mechanical strength to the membrane and may be any porous membrane used for ultra filtration, nanofiltration, or reverse osmosis. Examples of such materials are polyacrylonitrile, polyamideimide in combination with titanium oxide, polyetherimide, polyvinylidenedifluoride, polytetrafluoroethylene or combinations thereof.

During separation of clogging compositions from liquid stream 234, the pressure difference across the membrane may range from 5 bars to 60 bars, from 10 bars to 50 bars, or from 20 bars to 40 bars. A temperature of separation may range from the pour point of the liquid stream up to 100 °C, from about -20 °C to about 100 °C, from 10 °C to 90 °C, or from 20 °C to 85 °C. During a continuous operation, the permeate flux rate may be at most 50% of the initial flux, at most 70% of the initial flux, or at most 90% of the initial flux. A weight recovery of the permeate on feed may range between 50% by weight to 97% by weight, from 60% by weight to 90% by weight, or from 70% by weight to 80% by weight.

Filtration system 236 may include one or more membrane separators. The membrane separators may include one or more membrane modules. When two or more membrane separators are used, they may be arranged in a parallel configuration to allow feed (retentate) from a first membrane separator to flow into a second membrane separator. Examples of membrane modules include, but are not limited to, spirally wound modules, plate and frame modules, hollow fibers, and tubular modules. Membrane modules are described in Encyclopedia of Chemical Engineering, 4th Ed., 1995, John Wiley & Sons Inc., Vol. 16, pages 158-164. Examples of spirally wound modules are described in, for example, WO/2006/040307 to Boestert et al., U.S. Patent No. 5,102,551 to Pasternak; 5,093,002 to Pasternak; 5,275,726 to Feimer et al.; 5,458,774 to Mannapperuma; and 5,150,118 to Finkle et al, all of which are incorporated by reference herein.

In some embodiments, a spirally wound module is used when a dense membrane is used in filtration system 236. A spirally wound module may include a membrane assembly of two membrane sheets between which a permeate spacer sheet is sandwiched, and which membrane assembly is sealed at three sides. The fourth side is connected to a permeate outlet conduit such that the area between the membranes in fluid communication with the interior of the conduit. On top of one of the membranes a feed spacer sheet is arranged, and the assembly with feed spacer sheet is rolled up around the permeate outlet conduit, to form a

substantially cylindrical spirally wound membrane module. The feed spacer may have a thickness of at least 0.6 mm, at least 1 mm, or at least 3 mm to allow sufficient membrane surface to be packed into a spirally wound module. In some embodiments, the feed spacer is a woven feed spacer. During operation, a feed mixture may be passed from one end of the cylindrical module between the membrane assemblies, along the feed spacer sheet sandwiched between feed sides of the membranes. Part of the feed mixture passes through either one of the membrane sheets to the permeate side. The resulting permeate flows along the permeate spacer sheet into the permeate outlet conduit.

In some embodiments, the membrane separation is a continuous process. Liquid stream 234 passes over the membrane due to a pressure difference to obtain a filtered liquid stream 238 (permeate) and/or recycle liquid stream 240 (retentate). In some embodiments, filtered liquid stream 238 may have reduced concentrations of compositions and/or particles that cause clogging in downstream processing systems. Continuous recycling of recycle liquid stream 240 through nanofiltration system can increase the production of filtered liquid stream 238 to as much as 95% of the original volume of liquid stream 234. Recycle liquid stream 240 may be continuously recycled through a spirally wound membrane module for at least 10 hours, for at least one day or for at least one week without cleaning the feed side of the membrane. Upon completion of the filtration, waste stream 242 (retentate) may include a high concentration of compositions and/or particles that cause clogging. Waste stream 242 exits filtration system 236 and is transported to other processing units such as, for example, a delayed coking unit and/or a gasification unit.

Filtered liquid stream 238 may exit filtration system 236 and enter one or more process units. Process units as described herein for the production of crude products and/or commercial products may be operated at the following temperatures, pressures, hydrogen source flows, liquid stream flows, or combinations thereof, or operated otherwise as known in the art. Temperatures range from about 200 °C to about 900 °C, from about 300 °C to about 800 °C, or from about 400 °C to about 700 °C. Pressures range from about 0.1 MPa to about 20 MPa, from about 1 MPa to about 12 MPa, from about 4 MPa to about 10 MPa, or from about 6 MPa to about 8 MPa. Liquid hourly space velocities of the liquid stream range from about 0.1 h⁻¹ to about 30 h⁻¹, from about 0.5 h⁻¹ to about 25 h⁻¹, from about 1 h⁻¹ to about 20 h⁻¹, from about 1.5 h⁻¹ to about 15 h⁻¹, or from about 2 h⁻¹ to about 10 h⁻¹.

In FIG. 2, filtered liquid stream 238 and hydrogen source 244 enter hydrotreating unit 248. In some embodiments, hydrogen source 244 may be added to filtered liquid stream 238 before entering hydrotreating unit 248. In some embodiments, sufficient hydrogen is present in liquid stream 234 and hydrogen source 244 is not needed. In hydrotreating unit 248, contact of filtered liquid stream 238 with hydrogen source 244 in the presence of one or more catalysts produces liquid stream 250. Hydrotreating unit 248 may be operated such that all or at least a portion of liquid stream 250 is changed sufficiently to remove compositions and/or inhibit formation of compositions that may clog equipment positioned downstream of the hydrotreating unit 248. The catalyst used in hydrotreating unit 248 may be a commercially available catalyst. In some embodiments, hydrotreating of liquid stream 234 is not necessary.

In some embodiments, liquid stream 234 is contacted with hydrogen in the presence of one or more catalysts to change one or more desired properties of the crude feed to meet transportation and/or refinery specifications. Methods to change one or more desired properties of the crude feed are described in U.S. Published Patent Applications Nos. 20050133414 to Bhan et al.; 20050133405 to Wellington et al.; and

U.S. Patent Application Serial Nos. 11/400,542 entitled "Systems, Methods, and Catalysts for Producing a Crude Product" filed April 7, 2006; 11/425,979 to Bhan entitled "Systems, Methods, and Catalysts for Producing a Crude Product" filed June 6, 2006; and 11/425,992 to Wellington et al., entitled "Systems, Methods, and Catalysts for Producing a Crude Product" filed June 6, 2006 all of which are incorporated by
5 reference herein.

In some embodiments, hydrotreating unit 248 is a selective hydrogenation unit. In hydrotreating unit 248, liquid stream 234 and/or filtered liquid stream 238 are selectively hydrogenated such that di-olefins are reduced to mono-olefins. For example, liquid stream 234 and/or filtered liquid stream 238 is contacted with hydrogen in the presence of a DN-200 (Criterion Catalysts & Technologies, Houston Texas, U.S.A.) at
10 temperatures ranging from 100 °C to 200 °C and total pressures of 0.1 MPa to 40 MPa to produce liquid stream 250. Liquid stream 250 includes a reduced content of di-olefins and an increased content of mono-olefins relative to the di-olefin and mono-olefin content of liquid stream 234. The conversion of di-olefins to mono-olefins under these conditions is, in some embodiments, at least 50%, at least 60%, at least 80% or at least 90%. Liquid stream 250 exits hydrotreating unit 248 and enters one or more processing units
15 positioned downstream of hydrotreating unit 248. The units positioned downstream of hydrotreating unit 248 may include distillation units, catalytic reforming units, hydrocracking units, hydrotreating units, hydrogenation units, hydrodesulfurization units, catalytic cracking units, delayed coking units, gasification units, or combinations thereof.

Liquid stream 250 may exit hydrotreating unit 248 and enter fractionation unit 252. Fractionation
20 unit 252 produces one or more crude products. Fractionation may include, but is not limited to, an atmospheric distillation process and/or a vacuum distillation process. Crude products include, but are not limited to, C3-C5 hydrocarbon stream 254, naphtha stream 256, kerosene stream 258, diesel stream 262, and bottoms stream 264. Bottoms stream 264 generally includes hydrocarbons having a boiling range distribution of at least 340 °C at 0.101 MPa. In some embodiments, bottoms stream 264 is vacuum gas oil.
25 In other embodiments, bottoms stream includes hydrocarbons with a boiling range distribution of at least 537 °C. One or more of the crude products may be sold and/or further processed to gasoline or other commercial products.

To enhance the use of the streams produced from formation fluid, hydrocarbons produced during fractionation of the liquid stream and hydrocarbon gases produced during separating the process gas may be
30 combined to form hydrocarbons having a higher carbon number. The produced hydrocarbon gas stream may include a level of olefins acceptable for alkylation reactions.

In some embodiments, hydrotreated liquid streams and/or streams produced from fractions (e.g., distillates and/or naphtha) are blended with the in situ heat treatment process liquid and/or formation fluid to produce a blended fluid. The blended fluid may have enhanced physical stability and chemical stability as
35 compared to the formation fluid. The blended fluid may have a reduced amount of reactive species (e.g., di-olefins, other olefins and/or compounds containing oxygen, sulfur and/or nitrogen) relative to the formation fluid, thus chemical stability of the blended fluid is enhanced. The blended fluid may decrease an amount of asphaltenes relative to the formation fluid, thus physical stability of the blended fluid is enhanced. The blended fluid may be a more a fungible feed than the formation fluid and/or the liquid stream produced from

an in situ heat treatment process. The blended feed may be more suitable for transportation, for use in chemical processing units and/or for use in refining units than formation fluid.

In some embodiments, a fluid produced by methods described herein from an oil shale formation may be blended with heavy oil/tar sands in situ heat treatment process (IHTP) fluid. Since the oil shale liquid is substantially paraffinic and the heavy oil/tar sands IHTP fluid is substantially aromatic, the blended fluid exhibits enhanced stability. In certain embodiments, in situ heat treatment process fluid may be blended with bitumen to obtain a feed suitable for use in refining units. Blending of the IHTP fluid and/or bitumen with the produced fluid may enhance the chemical and/or physical stability of the blended product, thus the blend may be transported and/or distributed to processing units.

C₃-C₅ hydrocarbon stream 254 produced from fractionation unit 252 and hydrocarbon gas stream 224 enter alkylation unit 266. In alkylation unit 266, reaction of the olefins in hydrocarbon gas stream 224 (for example, propylene, butylenes, amylenes, or combinations thereof) with the iso-paraffins in C₃-C₅ hydrocarbon stream 254 produces hydrocarbon stream 268. In some embodiments, the olefin content in hydrocarbon gas stream 224 is acceptable and an additional source of olefins is not needed. Hydrocarbon stream 268 includes hydrocarbons having a carbon number of at least 4. Hydrocarbons having a carbon number of at least 4 include, but are not limited to, butanes, pentanes, hexanes, heptanes, and octanes. In certain embodiments, hydrocarbons produced from alkylation unit 266 have an octane number greater than 70, greater than 80, or greater than 90. In some embodiments, hydrocarbon stream 268 is suitable for use as gasoline without further processing.

In some embodiments, bottoms stream 264 may be hydrocracked to produce naphtha and/or other products. The resulting naphtha may, however, need reformation to alter the octane level so that the product may be sold commercially as gasoline. Alternatively, bottoms stream 264 may be treated in a catalytic cracker to produce naphtha and/or feed for an alkylation unit. In some embodiments, naphtha stream 256, kerosene stream 258, and diesel stream 262, have an imbalance of paraffinic hydrocarbons, olefinic hydrocarbons and/or aromatic hydrocarbons. The streams may not have a suitable quantity of olefins and/or aromatics for use in commercial products. This imbalance may be changed by combining at least a portion of the streams to form combined stream 266 which has a boiling range distribution from 38 °C to about 343 °C. Catalytically cracking combined stream 266 may produce olefins and/or other streams suitable for use in an alkylation unit and/or other processing units. In some embodiments, naphtha stream 256 is hydrocracked to produce olefins.

In FIG. 2, combined stream 266 and bottoms stream 264 from fractionation unit 252 enters catalytic cracking unit 270. Under controlled cracking conditions (for example, controlled temperatures and pressures), catalytic cracking unit 270 produces additional C₃-C₅ hydrocarbon stream 254', gasoline hydrocarbons stream 272, and additional kerosene stream 258'.

Additional C₃-C₅ hydrocarbon stream 254' may be sent to alkylation unit 266, combined with C₃-C₅ hydrocarbon stream 254, and/or combined with hydrocarbon gas stream 224 to produce gasoline suitable for sale. In some embodiments, the olefin content in hydrocarbon gas stream 224 is acceptable and an additional source of olefins is not needed.

In some embodiments, an amount of the produced bottoms stream (e.g., VGO) is too low to sustain operation of a hydrocracking unit or catalytic cracking unit and the concentration of olefins in the produced

gas streams from a fractionation unit and/or a catalytic cracking unit (for example, from fractionation unit 252 and/or from catalytic cracking unit 270 in FIG. 2) may be too low to sustain operation of an alkylation unit. The naphtha produced from the fractionation unit may be treated to produce olefins for further processing in, for example, an alkylation unit. Reformulated gasoline produced by conventional naphtha reforming processes may not meet commercial specifications such as, for example, California Air Resources Board mandates when liquid stream produced from an in situ heat treatment process liquid are used as a feed stream. An amount of olefins in the naphtha may be saturated during conventional hydrotreating prior to the reforming naphtha process. Thus, reforming of all the hydrotreated naphtha may result in a higher than desired aromatics content in the gasoline pool for reformulated gasoline. The imbalance in the olefin and aromatic content in the reformed naphtha may be changed by producing sufficient alkylate from an alkylation unit to produce reformulated gasoline. Olefins, for example propylene and butylenes, generated from fractionation and/or cracking of the naphtha may be combined with isobutane to produce gasoline. In addition, it has been found that catalytically cracking the naphtha and/or other fractionated streams produced in a fractionating unit requires additional heat because of a reduce amount of coke production relative to other feedstocks used in catalytic cracking units.

FIG. 3 depicts a schematic for treating liquid streams produced from an in situ heat treatment process stream to produce olefins and/or liquid streams. Similar processes to produce middle distillate and olefins are described in International Publication No. WO 2006/020547 and U.S. Patent Application Publication Nos. 20060191820 and 20060178546 to Mo et al., all of which are incorporated by referenced herein. Liquid stream 274 enters catalytic cracking system 278. Liquid stream 274 may include, but is not limited to, liquid stream 234, hydrotreated liquid stream 250, filtered liquid stream 238, naphtha stream 256, kerosene stream 258, diesel stream 262, and bottoms stream 264 from the system depicted in FIG. 2, any hydrocarbon stream having a boiling range distribution between 65 °C and 800 °C, or mixtures thereof. In some embodiments, steam 276 enters catalytic cracking system 278 and may atomize and/or lift liquid stream 274 to enhance contact of the liquid stream with the catalytic cracking catalyst. A ratio of steam to atomize liquid stream 274 to feedstock may range from 0.01 to 2 w/w, or from 0.1 to 1 w/w.

In catalytic cracking system 278, liquid stream 274 is contacted with a catalytic cracking catalyst to produce one or more crude products. The catalytic cracking catalyst includes a selected catalytic cracking catalyst, at least a portion of used regenerated cracking catalyst stream 280, at least a portion of a regenerated cracking catalyst stream 282, or a mixture thereof. Used regenerated cracking catalyst 280 includes a regenerated cracking catalyst that has been used in second catalytic cracking system 284. Second catalytic cracking system 284 may be used to crack hydrocarbons to produce olefins and/or other crude products. Hydrocarbons provided to second catalytic cracking system 284 may include C3-C5 hydrocarbons produce from the production wells, gasoline hydrocarbons, hydrowax, hydrocarbons produced from Fischer-Tropsch processes, biofuels, or combinations thereof. The use of a mixture of different types of hydrocarbon feed to the second catalytic cracking system may enhance C3-C5 olefin production to meet the alkylate demand. Thus, integration of the products with refinery processes may be enhanced. Second catalytic cracking system 284 may be a dense phase unit, a fixed fluidized bed unit, a riser, a combination of the above mentioned units, or any unit or configuration of units known in the art for cracking hydrocarbons.

Contact of the catalytic cracking catalyst and the liquid stream 274 in catalytic cracking system 278 produces a crude product and spent cracking catalyst. The crude product may include, but is not limited to, hydrocarbons having a boiling point distribution that is less than the boiling point distribution of liquid stream 274, a portion of liquid stream 274, or mixtures thereof. The crude product and spent catalyst enters separation system 286. Separation system 286 may include, for example, a distillation unit, a stripper, a filtration system, a centrifuge, or any device known in the art capable of separating the crude product from the spent catalyst.

Separated spent cracking catalyst stream 288 exits separation system 286 and enters regeneration unit 290. In regeneration unit 290, spent cracking catalyst is contacted with oxygen source 292 such as, for example, oxygen and/or air, under carbon burning conditions to produce regenerated cracking catalyst stream 282 and combustion gases 294. Combustion gases may form as a by-product of the removal of carbon and/or other impurities formed on the catalyst during the catalytic cracking process.

The temperature in regeneration unit 290 may range from about 621 °C to 760 °C or from 677 °C to 715 °C. The pressure in regeneration unit 290 may range from atmospheric to 0.345 MPa or from 0.034 to 0.345 MPa. The residence time of the separated spent cracking catalyst in regeneration unit 290 ranges from about 1 to about 6 minutes or from or about 2 to or about 4 minutes. The coke content on the regenerated cracking catalyst is less than the coke content on the separated spent cracking catalyst. Such coke content is less than 0.5 wt. %, with the weight percent being based on the weight of the regenerated cracking catalyst excluding the weight of the coke content. The coke content of the regenerated cracking catalyst may range from 0.01% by weight to 0.5% by weight, 0.05% by weight to 0.3% by weight, or 0.1% by weight to 0.1% by weight.

In some embodiments, regenerated cracking catalyst stream 282 may be divided into two streams with at least a portion of regenerated cracking catalyst stream 282' exiting regeneration unit 290 and entering second catalytic cracking system 284. At least another portion of regenerated cracking catalyst stream 282 exits regenerator 290 and enters catalytic cracking system 278. The relative amount of the used regenerated cracking catalyst to the regenerated cracking catalyst is adjusted to provide for the desired cracking conditions within catalytic cracking system 278. Adjusting the ratio of used regenerated cracking catalyst to regenerated cracking catalyst may assist in the control of the cracking conditions in catalytic cracking system 278. A weight ratio of the used regenerated cracking catalyst to the regenerated cracking catalyst may range from 0.1:1 to 100:1, from 0.5:1 to 20:1, or from 1:1 to 10:1. For a system operated at steady state, the weight ratio of used regenerated cracking catalyst-to-regenerated cracking catalyst approximates the weight ratio of the at least a portion of regenerated cracking catalyst passing to the second catalytic cracking system 284 to the remaining portion of regenerated cracking catalyst that is mixed with liquid stream 274 introduced into catalytic cracking system 278, and, thus, the aforementioned ranges are also applicable to such weight ratio.

Crude product 296 exits separation system 286 and enters liquid separation unit 298. Liquid separation unit 298 may be any system known to those skilled in the art for recovering and separating the crude product into product streams such as, for example, gas stream 228', gasoline hydrocarbons stream 300, cycle oil stream 302, and bottom stream 304. In some embodiments, bottom stream 304 is recycled to catalytic cracking system 278. Liquid separation unit 298 may include components and/or units such as, for example, absorbers and strippers, fractionators, compressors and separators or any combination of known

systems for providing recovery and separation of products from the crude product. In some embodiments, at least a portion of light cycle oil stream 302 exits liquid separation unit 298 and enters second catalytic cracking system 278. In some embodiments, none of the light cycle oil stream is sent to the second catalytic cracking system. In some embodiments, at least a portion of gasoline hydrocarbons stream 300 exits liquid separation unit 298 and enters second catalytic cracking system 284. In some embodiments, none of the gasoline hydrocarbons stream is sent to the second catalytic cracking system. In some embodiments, gasoline hydrocarbons stream 300 is suitable for sale and/or for use in other processes.

Gas oil hydrocarbon stream 306 (for example, vacuum gas oil) and/or portions of gasoline hydrocarbons stream 300 and light cycle oil stream 302 are sent to catalytic cracking system 284. The steams are catalytically cracked in the presence of steam 276' to produce crude olefin stream 308. Crude olefin stream 308 may include hydrocarbons having a carbon number of at least 2. In some embodiments, crude olefin stream 308 contains at least 30% by weight C₂-C₅ olefins, 40% by weight C₂-C₅ olefins, at least 50% by weight C₂-C₅ olefins, at least 70% by weight C₂-C₅ olefins, or at least 90% by weight C₂-C₅ olefins. The recycling of the gasoline hydrocarbons stream 300 into second catalytic cracking system 284 may provide for an additional conversion across the overall process system of gas oil hydrocarbon stream 306 to C₂-C₅ olefins.

In some embodiments, second catalytic cracking system 284 includes an intermediate reaction zone and a stripping zone that are in fluid communication with each other with the stripping zone located below the intermediate reaction zone. To provide for a high steam velocity within the stripping zone, as compared to its velocity within the intermediate reaction zone, the cross sectional area of the stripping zone is less than the cross sectional area of the intermediate reaction zone. The ratio of the stripping zone cross sectional area to the intermediate reaction zone cross sectional area may range from 0.1:1 to 0.9:1; 0.2:1 to 0.8:1; or from 0.3:1 to 0.7:1.

In some embodiments, the geometry of the second catalytic cracking system is such that it is generally cylindrical in shape, the length-to-diameter ratio of the stripping zone is such as to provide for the desired high steam velocity within the stripping zone and to provide enough contact time within the stripping zone for the desired stripping of the used regenerated catalyst that is to be removed from the second catalytic cracking system. Thus, the length-to-diameter dimension of the stripping zone may range of from 1:1 to 25:1; from 2:1 to 15:1; or from 3:1 to 10:1.

In some embodiments, second catalytic cracking system 284 is operated or controlled independently from the operation or control of the catalytic cracking system 278. This independent operation or control of second catalytic cracking system 284 may improve overall conversion of the gasoline hydrocarbons into the desired products such as ethylene, propylene and butylenes. With the independent operation of second catalytic cracking system 284, the severity of catalytic cracking unit 278 may be reduced to optimize the yield of C₂-C₅ olefins. A temperature in second catalytic cracking system 284 may range from 482 °C (900 °F) to about 871 °C (1600 °F), from 510 °C. (950 °F) to 871 °C (1600 °F), or from 538 °C (1000 °F) to 732 °C (1350 °F). The operating pressure of second catalytic cracking system 284 may range from atmospheric to about 0.345 MPa (50 psig) or from about 0.034 to 0.345 MPa (5 to 50 psig).

Addition of steam 276' into second catalytic cracking system 284 may assist in the operational control of the second catalytic cracking unit. In some embodiments, steam is not necessary. In some

embodiments, the use of the steam for a given gasoline hydrocarbon conversion across the process system, and in the cracking of the gasoline hydrocarbons may provide for an improved selectivity toward C₂-C₅ olefin yield with an increase in propylene and butylenes yield relative to other catalytic cracking processes. A weight ratio of steam to gasoline hydrocarbons introduced into second catalytic cracking system 284 may
5 be in the range of upwardly to or about 15:1; from 0.1:1 to 10:1; from 0.2:1 to 9:1; or from 0.5:1 to 8:1.

Crude olefin stream 308 enters olefin separation system 310. Olefin separation system 310 can be any system known to those skilled in the art for recovering and separating the crude olefin stream 308 into C₂-C₅ olefin product streams, for example ethylene product stream 312, propylene product stream 314, and butylenes products stream 316. Olefin separation system 310 may include such systems as absorbers and
10 strippers, fractionators, compressors and separators or any combination of known systems or equipment providing for the recovery and separation of C₂-C₅ olefin products from fluid stream 308. In some embodiments, olefin streams 312, 314, 316 enter alkylation unit 266 to generate hydrocarbon stream 268. In some embodiments, hydrocarbon stream 268 has an octane number of at least 70, at least 80, or at least 90. In some embodiments, all or portions of one or more of streams 312, 314, 316 are transported to other
15 processing units, such as polymerization units, for use as feedstocks.

In some embodiments, the crude product from the catalytic cracking system and the crude olefin stream from second catalytic cracking system may be combined. The combined stream may enter a single separation unit (for example, a combination of liquid separation system 298 and olefin separation system 310).

In FIG. 3, used cracking catalyst stream 280 exits second catalytic cracking system 284 and enters catalytic cracking system 278. Catalyst in used cracking catalyst stream 280 may include a slightly higher concentration of carbon than the concentration of carbon that is on the catalyst in regenerated cracking catalyst 282. A high concentration of carbon on the catalyst may partially deactivate the catalytic cracking catalysts which provides for an enhance yield of olefins from the catalytic cracking system 278. Coke
25 content of the used regenerated catalyst may be at least 0.1% by weight or at least 0.5% by weight. The coke content of the used regenerated catalyst may range from 0.1% by weight to about 1% by weight or from 0.1% by weight to 0.6% by weight.

The catalytic cracking catalyst used in catalytic cracking system 278 and second catalytic cracking system 284 may be any fluidizable cracking catalyst known in the art. The fluidizable cracking catalyst may
30 include a molecular sieve having cracking activity dispersed in a porous, inorganic refractory oxide matrix or binder. "Molecular sieve" refers to any material capable of separating atoms or molecules based on their respective dimensions. Molecular sieves suitable for use as a component of the cracking catalyst include pillared clays, delaminated clays, and crystalline aluminosilicates. In some embodiments, the cracking catalyst contains a crystalline aluminosilicate. Examples of such aluminosilicates include Y zeolites,
35 ultrastable Y zeolites, X zeolites, zeolite beta, zeolite L, offretite, mordenite, faujasite, and zeolite omega. In some embodiments, crystalline aluminosilicates for use in the cracking catalyst are X and/or Y zeolites. U.S. Pat. No. 3,130,007 to Breck describes Y-type zeolites.

The stability and/or acidity of a zeolite used as a component of the cracking catalyst may be increased by exchanging the zeolite with hydrogen ions, ammonium ions, polyvalent metal cations, such as
40 rare earth-containing cations, magnesium cations or calcium cations, or a combination of hydrogen ions,

ammonium ions and polyvalent metal cations, thereby lowering the sodium content until it is less than about 0.8 weight percent, preferably less than about 0.5 weight percent and most preferably less than about 0.3 weight percent, calculated as Na_2O . Methods of carrying out the ion exchange are well known in the art.

The zeolite or other molecular sieve component of the cracking catalyst is combined with a porous, inorganic refractory oxide matrix or binder to form a finished catalyst prior to use. The refractory oxide component in the finished catalyst may be silica-alumina, silica, alumina, natural or synthetic clays, pillared or delaminated clays, mixtures of one or more of these components and the like. In some embodiments, the inorganic refractory oxide matrix includes a mixture of silica-alumina and a clay such as kaolin, hectorite, sepiolite, and attapulgite. A finished catalyst may contain between about 5 weight percent to about 40 weight percent zeolite or other molecular sieve and greater than about 20 weight percent inorganic refractory oxide. In some embodiments, the finished catalyst may contain between about 10 to about 35 weight percent zeolite or other molecular sieve, between about 10 to about 30 weight percent inorganic refractory oxide, and between about 30 to about 70 weight percent clay.

The crystalline aluminosilicate or other molecular sieve component of the cracking catalyst may be combined with the porous, inorganic refractory oxide component or a precursor thereof by any suitable technique known in the art including mixing, mulling, blending or homogenization. Examples of precursors that may be used include, but are not limited to, alumina, alumina sols, silica sols, zirconia, alumina hydrogels, polyoxocations of aluminum and zirconium, and peptized alumina. In some embodiments, the zeolite is combined with an alumino-silicate gel or sol or other inorganic, refractory oxide component, and the resultant mixture is spray dried to produce finished catalyst particles normally ranging in diameter between about 40 and about 80 microns. In some embodiments, the zeolite or other molecular sieve may be milled or otherwise mixed with the refractory oxide component or precursor thereof, extruded and then ground into the desired particle size range. The finished catalyst may have an average bulk density between about 0.30 and about 0.90 gram per cubic centimeter and a pore volume between about 0.10 and about 0.90 cubic centimeter per gram.

In some embodiments, a ZSM-5 additive may be introduced into the intermediate cracking reactor of second catalytic cracking system 284. When a ZSM-5 additive is used along with the selected cracking catalyst in the intermediate cracking reactor, a yield of the lower olefins such as propylene and butylenes is enhanced. An amount of ZSM-5 ranges from at most 30% by weight, at most 20% by weight, or at most 18% by weight of the regenerated catalyst being introduced into second catalytic cracking system 284. An amount of ZSM-5 additive is introduced into second catalytic cracking system 284 may range from 1% to 30% by weight, 3% to 20% by weight, or 5% to 18% by weight of the regenerated cracking catalyst being introduced into second catalytic cracking system 284.

The ZSM-5 additive is a molecular sieve additive selected from the family of medium pore size crystalline aluminosilicates or zeolites. Molecular sieves that can be used as the ZSM-5 additive include, but are not limited to, medium pore zeolites as described in "Atlas of Zeolite Structure Types," Eds. W. H. Meier and D. H. Olson, Butterworth-Heinemann, Third Edition, 1992. The medium pore size zeolites generally have a pore size from about 0.5 nm, to about 0.7 nm and include, for example, MFI, MFS, MEL, MTW, EUO, MTT, HEU, FER, and TON structure type zeolites (IUPAC Commission of Zeolite Nomenclature). Non-limiting examples of such medium pore size zeolites, include ZSM-5, ZSM-12, ZSM-22, ZSM-23, ZSM-34,

ZSM-35, ZSM-38, ZSM-48, ZSM-50, silicalite, and silicalite 2. ZSM-5, are described in U.S. Pat. Nos. 3,702,886 to Argauer et al. and U.S. Patent No. 3,770,614 to Graven, both of which are incorporated by reference herein.

ZSM-11 is described in U.S. Pat. No. 3,709,979 to Chu; ZSM-12 in U.S. Pat. No. 3,832,449 to Rosinski et al.; ZSM-21 and ZSM-38 in U.S. Pat. No. 3,948,758 to Bonacci et al.; ZSM-23 in U.S. Pat. No. 4,076,842 to Plank et al.; and ZSM-35 in U.S. Pat. No. 4,016,245 to Plank et al., all of which are incorporated by reference herein. Other suitable molecular sieves include the silicoaluminophosphates (SAPO), such as SAPO-4 and SAPO-11 which is described in U.S. Pat. No. 4,440,871 to Lok et al.; chromosilicates; gallium silicates, iron silicates; aluminum phosphates (ALPO), such as ALPO-11 described in U.S. Pat. No. 4,310,440 to Wilson et al.; titanium aluminosilicates (TASO), such as TASO-45 described in U.S. Pat. No. 4,686,029 to Pellet et al.; boron silicates, described in U.S. Pat. No. 4,254,297 Frenken et al.; titanium aluminophosphates (TAPO), such as TAPO-11 described in U.S. Pat. No. 4,500,651 to Lok et al.; and iron aluminosilicates, all of which are incorporated by reference herein.

U.S. Pat. No. 4,368,114 to Chester et al., which is incorporated by reference herein, describes in detail the class of zeolites that can be suitable ZSM-5 additives. The ZSM-5 additive may be held together with a catalytically inactive inorganic oxide matrix component, in accordance with conventional methods.

In some embodiments, residue produced from units described in FIGS. 2 and 3 may be used as an energy source. The residue may be gasified to produce gases which are burned (e.g., burned in a turbine) and/or injected into a subsurface formation (e.g., injection of produced carbon dioxide into a subsurface formation). In certain embodiments, the residue is de-asphalted to produce asphalt. The asphalt may be gasified.

Examples

Non-limiting examples of filtration of a in situ heat treated liquid stream and production of olefins from an in situ heat treated liquid stream are set forth below.

Example 1. Nanofiltration of an In Situ Heat Treatment Process Liquid Stream. A liquid sample (500 mL, 398.68 grams) was obtained from an in situ heat treatment process. The liquid sample contained 0.0069 grams of sulfur and 0.0118 grams of nitrogen per gram of liquid sample. The final boiling point of the liquid sample was 481 °C and the liquid sample had a density of 0.8474. The membrane separation unit used to filter the sample was a laboratory flat sheet membrane installation type P28 as obtained from CM Celfa Membrantechnik A.G. (Switzerland). A single 2-micron thick poly di-methyl siloxane membrane (GKSS Forschungszentrum GmbH, Geesthacht, Germany) was used as the filtration medium. The filtration system was operated at 50 °C and a pressure difference over the membrane was 10 bar. The pressure at the permeate side was nearly atmospheric. The permeate was collected and recycled through the filtration system to simulate a continuous process. The permeate was blanketed with nitrogen to prevent contact with ambient air. The retentate was also collected for analysis. The average flux of 2 kg/m²/bar/hr did not measurably decline from an initial flux during the filtration. The filtered liquid (298.15 grams, 74.7% recovery) contained 0.007 grams of sulfur and 0.0124 grams of nitrogen per gram of filtered liquid; and the filtered liquid had a density of 0.8459 and a final boiling point of 486 °C. The retentate (56.46 grams, 14.16% recovery) contained 0.0076 grams of sulfur and 0.0158 grams of nitrogen per gram of retentate; and the retentate had a density of 0.8714 and a final boiling point of 543 °C.

Example 2. Fouling Testing of Filtered and Unfiltered In Situ Heat Treatment Process Liquid

Streams. The unfiltered and filtered liquid samples from Example 1 were tested for fouling behavior.

Fouling behavior was determined using an Alcor thermal fouling tester. The Alcor thermal fouling tester is a miniature shell and tube heat exchanger made of 1018 steel which was grated with Norton R222 sandpaper before use. During the test the sample outlet temperature, (T_{out}) was monitored while the heat-exchanger temperature (T_c) was kept at a constant value. If fouling occurs and material is deposited on the tube surface, the heat resistance of the sample increases and consequently the outlet temperature decreases. The decrease in outlet temperature after a given period of time is a measure of fouling severity. The temperature decrease after two hours of operation is used as fouling severity indicator. $\Delta T = T_{out(o)} - T_{out(2h)}$. $T_{out(o)}$ is defined as the maximum (stable) outlet temperature obtained at the start of the test, $T_{out(2h)}$ is recorded 2 hours after the first noted decrease of the outlet temperature or when the outlet temperature has been stable for at least 2 hours.

During each test, the liquid sample was continuously circulated through the heat exchanger at approximately 3 mL/min. The residence time in the heat exchanger was about 10 seconds. The operating conditions were as follows: 40 bar of pressure, T_{sample} was about 50 °C, T_c was 350 °C, and test time was 4.41 hours. The ΔT for the unfiltered liquid stream sample was 15 °C. The ΔT for the filtered sample was zero.

This example demonstrates that nanofiltration of a liquid stream produced from an in situ heat treatment process removes at least a portion of clogging compositions.

Example 3. Production of Olefins from an In Situ Heat Treatment Process Liquid Stream.

An experimental pilot system was used to conduct the experiments. The pilot system included a feed supply system, a catalyst loading and transfer system, a fast fluidized riser reactor, a stripper, a product separation and collecting system, and a regenerator. The riser reactor was an adiabatic riser having an inner diameter of from 11 mm to 19 mm and a length of about 3.2 m. The riser reactor outlet was in fluid communication with the stripper that was operated at the same temperature as the riser reactor outlet flow and in a manner to provide essentially 100 percent stripping efficiency. The regenerator was a multi-stage continuous regenerator used for regenerating the spent catalyst. The spent catalyst was fed to the regenerator at a controlled rate and the regenerated catalyst was collected in a vessel. Material balances were obtained during each of the experimental runs at 30-minute intervals. Composite gas samples were analyzed by use of an on-line gas chromatograph and the liquid product samples were collected and analyzed overnight. The coke yield was measured by measuring the catalyst flow and by measuring the delta coke on the catalyst as determined by measuring the coke on the spent and regenerated catalyst samples taken for each run when the unit was operating at steady state.

A liquid stream produced from an in situ heat treatment process was fractionated to obtain a vacuum gas oil (VGO) stream having a boiling range distribution from 310 °C to 640°C. The VGO stream was contacted with a fluidized catalytic cracker E-Cat containing 10% ZSM-5 additive in the catalytic system described above. The riser reactor temperature was maintained at 593 °C (1100 °F). The product produced contained, per gram of product, 0.1402 grams of C_3 olefins, 0.137 grams of C_4 olefins, 0.0897 grams of C_5 olefins, 0.0152 grams of iso- C_5 olefins, 0.0505 grams isobutylene, 0.0159 grams of ethane, 0.0249 grams of isobutane, 0.0089 grams of n-butane, 0.0043 grams pentane, 0.0209 grams iso-pentane, 0.2728 grams of a

mixture of C₆ hydrocarbons and hydrocarbons having a boiling point of at most 232 °C (450 °F), 0.0881 grams of hydrocarbons having a boiling range distribution between 232 °C and 343 °C (between 450 °F and 650 °F), 0.0769 grams of hydrocarbons having a boiling range distribution between 343 °C and 399 °C (650 °F and 750 °F) and 0.0386 grams of hydrocarbons having a boiling range distribution of at least 399 °C (750 °F) and 0.0323 grams of coke.

This example demonstrates a method of producing crude product by fractionating liquid stream produced from separation of the liquid stream from the formation fluid to produce a crude product having a boiling point above 343 °C; and catalytically cracking the crude product having the boiling point above 343 °C to produce one or more additional crude products, wherein least one of the additional crude products is a second gas stream.

Example 4. Production of Olefins From A Liquid Stream Produced From An In Situ Heat Treatment Process. A thermally cracked naphtha was used to simulate a liquid stream produced from an in situ heat treatment process having a boiling range distribution from 30° C to 182 °C. The naphtha contained, per gram of naphtha, 0.186 grams of naphthenes, 0.238 grams of isoparaffins, 0.328 grams of n-paraffins, 0.029 grams cyclo-olefins, 0.046 grams of iso-olefins, 0.064 grams of n-olefins and 0.109 grams of aromatics. The naphtha stream was contacted with a FCC E-Cat with 10% ZSM-5 additive in the catalytically cracking system described above to produce a crude product. The riser reactor temperature was maintained at 593 °C (1100 °F). The crude product included, per gram of crude product, 0.1308 grams ethylene, 0.0139 grams of ethane, 0.0966 grams C₄-olefins, 0.0343 grams C₄ iso-olefins, 0.0175 grams butane, 0.0299 grams isobutane, 0.0525 grams C₅ olefins, 0.0309 grams C₅ iso-olefins, 0.0442 grams pentane, 0.0384 grams isopentane, 0.4943 grams of a mixture of C₆ hydrocarbons and hydrocarbons having a boiling point of at most 232 °C (450 °F), 0.0201 grams of hydrocarbons having a boiling range distribution between 232 °C and 343 °C (between 450 °F and 650 °F), 0.0029 grams of hydrocarbons having a boiling range distribution between 343 °C and 399 °C (650 °F and 750 °F) and 0.00128 grams of hydrocarbons having a boiling range distribution of at least 399 °C (750 °F) and 0.00128 grams of coke. The total amount of C₃-C₅ olefins was 0.2799 grams per gram of naphtha.

This example demonstrates a method of producing crude product by fractionating liquid stream produced from separation of the liquid stream from the formation fluid to produce a crude product having a boiling point above 343 °C; and catalytically cracking the crude product having the boiling point above 343 °C to produce one or more additional crude products, wherein least one of the additional crude products is a second gas stream.

CLAIMS

1. A method for producing a crude product, comprising:
 - 5 producing formation fluid from a subsurface in situ pyrolysis heat treatment process;
 - separating the formation fluid to produce a liquid stream and a first gas stream, wherein the first gas stream comprises olefins;
 - fractionating the liquid stream to produce one or more crude products, wherein at least one of the crude products has a boiling range distribution from 38 °C and 343 °C as determined by ASTM Method
10 D5307.; and
 - catalytically cracking the crude product having the boiling range distribution from 38 °C and 343 °C to produce one or more additional crude products, wherein at least one of the additional crude products is a second gas stream, and the gas stream has a boiling point of at most 38 °C at 0.101 MPa.
2. The method as claimed in claim 1, wherein the second gas stream comprises hydrocarbons having a
15 carbon number of at least 3.
3. The method as claimed in claims 1 or 2, wherein at least one of the additional crude products has a boiling range distribution between 38 °C and 200 °C as determined by ASTM Method D5307.
4. The method as claimed in any of claims 1-3, wherein at least one of the additional crude products comprise gasoline hydrocarbons.
- 20 5. The method as claimed in claim 4, wherein the gasoline hydrocarbons have an octane number of at least 70.
6. A method for producing hydrocarbons, comprising:
 - producing formation fluid from a subsurface in situ heat treatment process;
 - separating the formation fluid to produce a liquid stream;
 - 25 catalytically cracking the liquid stream in a first catalytic cracking system by contacting the liquid stream with a catalytic cracking catalyst to produce a crude product stream and a spent catalytic cracking catalyst;
 - regenerating the spent catalytic cracking catalyst to produce a regenerated cracking catalyst;
 - catalytically cracking a gasoline hydrocarbons stream in a second catalytic cracking system by contacting
30 the gasoline hydrocarbons stream with the regenerated catalytic cracking catalyst to produce a crude olefin stream comprising hydrocarbons having a carbon number of at least 2 and a used regenerated cracking catalyst; and
 - separating olefins from the crude olefin stream, wherein the olefins have a carbon number from 2 to 5; and
 - 35 providing the used regenerated cracking catalyst from the second catalytic cracking system to the first catalytic cracking system.
7. The method as claimed in claim 6, wherein the catalytic cracking catalyst comprises amorphous silica alumina and a zeolite.
8. The method as claimed in claims 6 or 7, further comprising providing ZSM-5 to the second
40 catalytically cracking system.

9. The method as claimed in any of claims 6-8, wherein a coke content of the regenerated catalytic cracking catalyst ranges from 0.01% by weight to 0.5% by weight.
10. The method as claimed in any of claims 6-9, wherein a weight ratio of the used regenerated cracking catalyst to the regenerated cracking catalyst ranges from 0.1:1 to 100:1.
- 5 11. The method as claimed in any of claims 6-10, further comprising providing steam to the first and/or second catalytic cracking systems.
12. The method as claimed in any of claims 6-11, further comprising separating the crude product into one or more hydrocarbon streams, wherein at least one of the hydrocarbons stream is a gasoline hydrocarbons stream; and providing at least a portion of the gasoline hydrocarbons stream to the second
10 catalytic cracking system.
13. The method as claimed in any of claim 12, wherein at least one of the hydrocarbons stream is a cycle oil stream; and providing at least a portion of the cycle oil stream to the first catalytic cracking system.
14. The method as claimed in any of claims 6-13, further comprising providing at least a portion of the olefins having a carbon number from 3 to 5 to an alkylation unit.
- 15 15. The method as claimed in any of claims 6-13, further comprising providing at least a portion of the olefins having a carbon number from 3 to 5 to an alkylation unit, and then alkylating the olefins to produce hydrocarbons suitable for blending to produce transportation fuel.
16. The method as claimed in claim 15, wherein the transportation fuel is gasoline.
17. The method as claimed in any of claims 6-16, further comprising providing at least a portion of the
20 olefins to a polymerization unit.
18. The method as claimed in any of claims 1-17, further comprising hydrotreating at least a portion of the liquid stream at conditions sufficient for removal of clogging compositions.
19. A method of making transportation fuel comprising: using one or more of the crude products produced by the method as claimed in any of claims 1-18.
- 25 20. Transportation fuel comprising hydrocarbons produced by the methods claimed in claims 1-19.

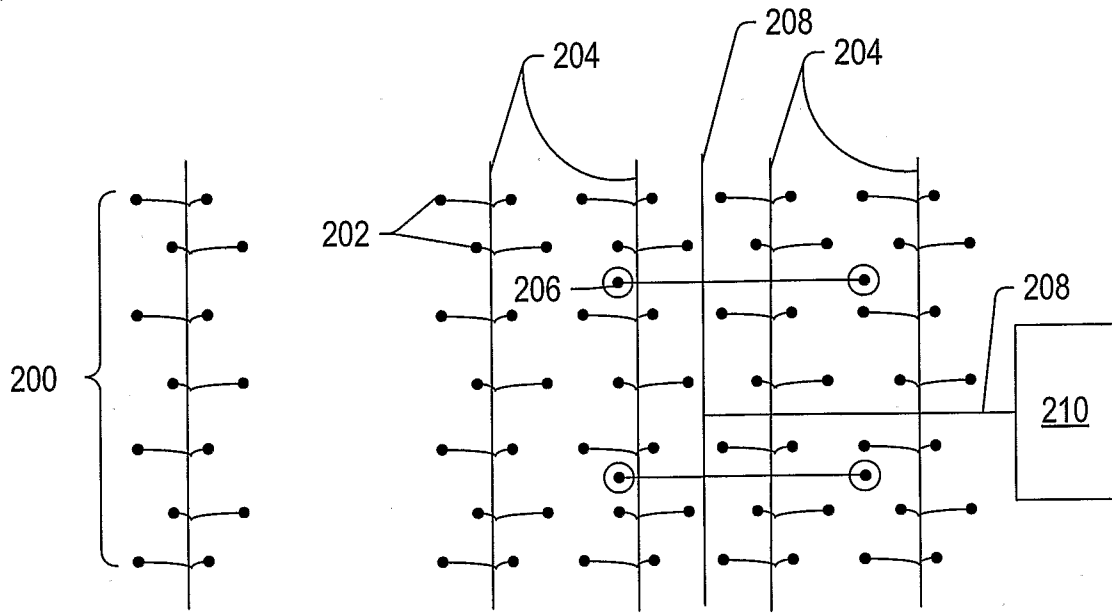

FIG. 1

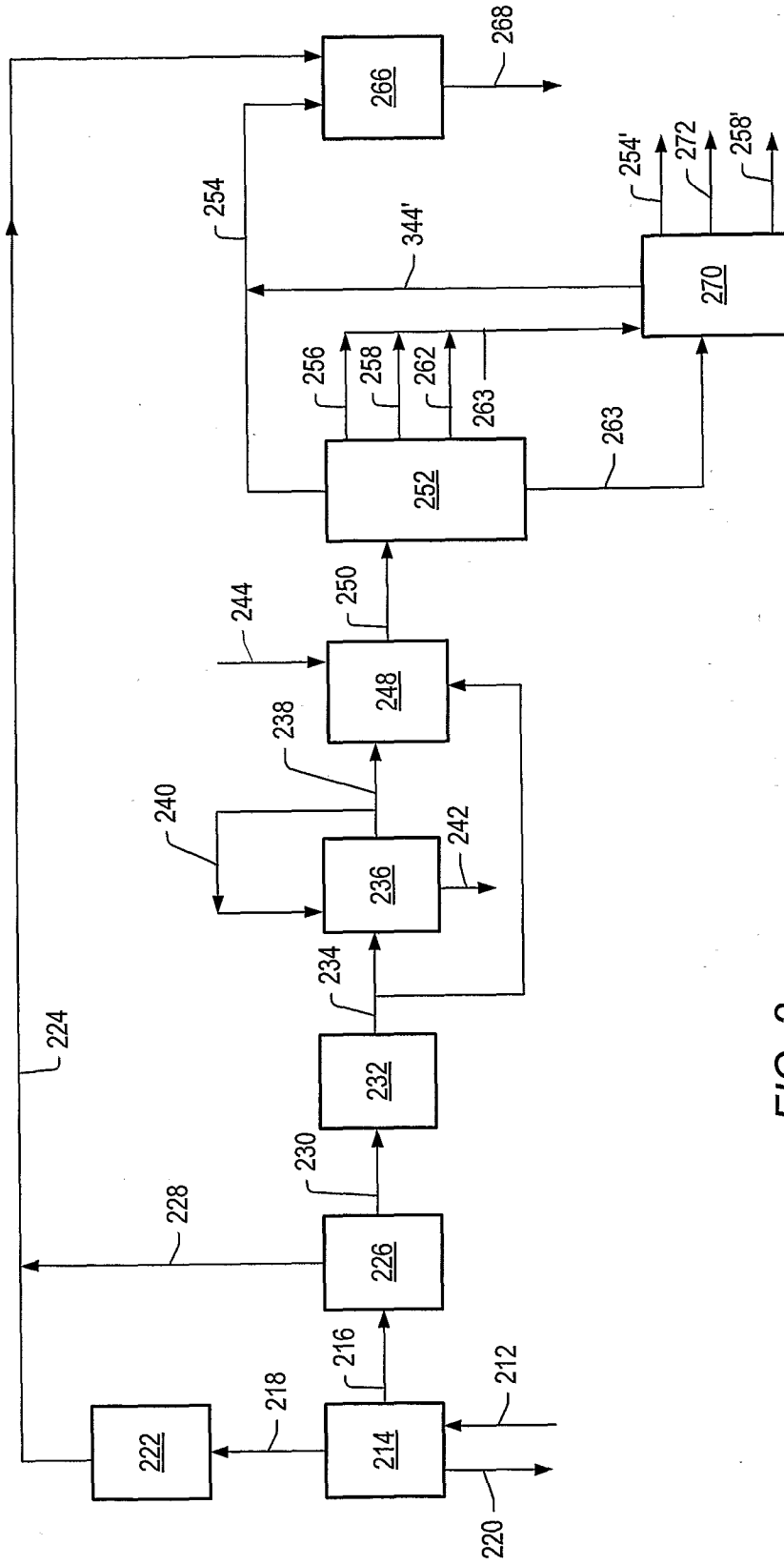

FIG. 2

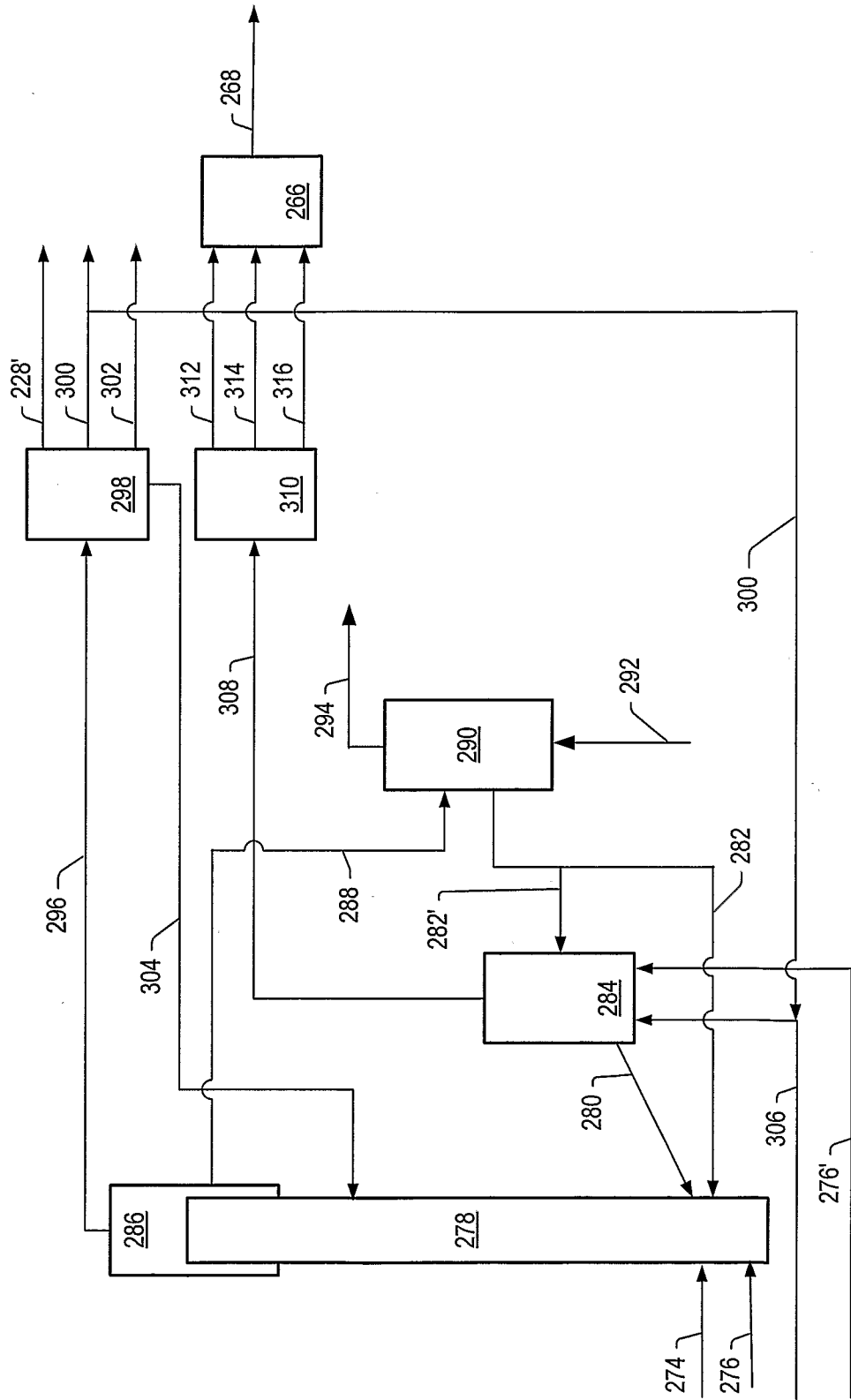

FIG. 3