

(19)



Europäisches Patentamt

European Patent Office

Office européen des brevets



(11)

EP 0 839 708 A2

(12)

EUROPEAN PATENT APPLICATION

(43) Date of publication:
06.05.1998 Bulletin 1998/19

(51) Int. Cl.⁶: B63B 27/24, B63B 13/00

(21) Application number: 97203502.6

(22) Date of filing: 02.11.1992

(84) Designated Contracting States:
AT BE CH DE DK ES FR GB GR IE IT LI LU MC NL
SE

(72) Inventor: Oyvind, Tveit
5045 Skjoldtun (NO)

(30) Priority: 28.01.1992 NO 920380

(74) Representative: Wallin, Bo-Göran
AWAPATENT AB,
Box 5117
200 71 Malmö (SE)

(62) Document number(s) of the earlier application(s) in
accordance with Art. 76 EPC:
93900466.9 / 0 623 084

Remarks:

This application was filed on 11 11 97 as a
divisional application to the application mentioned
under INID code 62.

(71) Applicant: FRANK MOHN FUSA A/S
N-5670 Fusa (NO)

(54) **Process and arrangement for draining a liquid residue from the bottom of a tank**

(57) A liquid residue (14) is drained from the bottom (10a) of a tank (10) via a drain pipe (15) having its open bottom intake end (13a) near the tank bottom, using a pump or ejector (16) arranged at a level substantially above the upper level of the liquid residue (14). The pump (16) or ejector establishes an upwardly directed gas/liquid current in the drain pipe (15). At distinct levels (A1, A2) above the upper surface of the liquid residue, a gas medium is sucked into the drain pipe (15) through gas inlet openings (19a, 19b) in the drain pipe wall in order to mix this gas medium with the gas/liquid current passing through the drain pipe (15).

FIG. 2

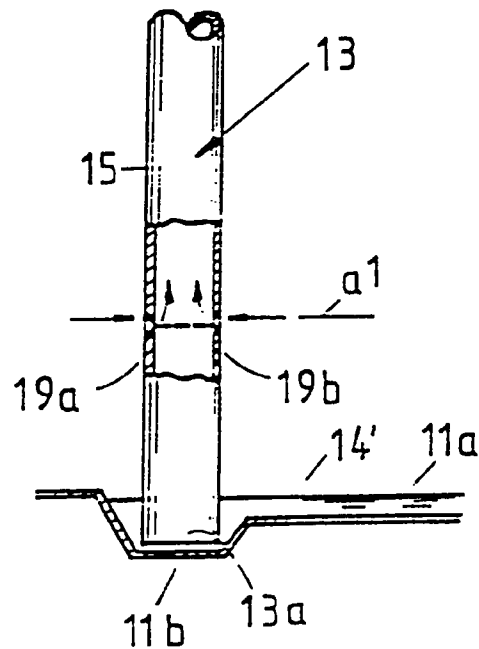

EP 0 839 708 A2

Description

The present invention relates to a process for draining a residue of liquid from the bottom of a tank via a drain pipe between the tank bottom and a pump or ejector, which is arranged at a level substantially above the bottom of the tank and preferably above the top of the tank, the pump or the ejector establishing a gas/liquid current in the drain pipe between the bottom of the tank and the pump or the ejector, wherein gas medium is supplied at least at one level in the drain pipe between the bottom of the tank and the pump or the ejector to the current of gas/liquid.

On draining a tank from its upper side there are limited possibilities of being able to lift a liquid column in a suction pipe by conventional means. A liquid having a density of for example 1 kg/dm^3 can theoretically be lifted by the effect of suction a height of 10 m, while in practice it can only be lifted a lifting height of about 7 m. In practice on lifting a liquid by the effect of suction one will be dependent on the specific gravity of the liquid and in addition its specific vapour pressure, the liquid which has a low vapour pressure beginning to "boil" at high suction pressures.

On pumping liquids out from a tank over large lifting heights, especially from a tank on board a tanker, it is usual to employ a pump aggregate, which has the pump submerged in the liquid of the tank just above the bottom of the tank and which has the intake of the pump arranged in a well-forming countersinking in the bottom of the tank. By this the liquid column can be lifted with a compressive force instead of a suction force. In tankers 20 meters lifting height is a typical lifting height for liquid which is to be discharged. With an arrangement with a submerged pump there is the possibility of draining the tank relatively rapidly and effectively with such lifting heights and also with greater lifting heights. In a final phase of the emptying certain liquid residues can be discharged by "stripping", that is to say for example by the air scavenging of substantial portions of the liquid which are left in the pump aggregate. All the time the question here is to "press" liquid upwardly through the drain pipe. However, at the termination of the discharge sequence, some of the liquid will in practice always leak back to the bottom of the tank. It has not been possible in practice to drain this final residue from the tank in a ready manner by mechanical means. In certain instances one has been obliged to remove a final residue from the well-forming countersinking of the order of magnitude of 50-100 litres manually or in another complicated manner.

In the publication INDUSTRIELL TEKNIK INDUSTRIIDNINGEN NORDEN, Volume 3, March 1973, Stockholm, Patentprofylax 9/73 is stated a process for draining of residue of liquid from the bottom of a tank by use of a pump and a drain pipe, wherein a gas medium is supplied so as to create a gas/liquid current and wherein the gas medium is entering the drain pipe

together with the liquid from the pipe inlet. In said publication is also stated a draining arrangement for draining a residue of liquid from the bottom of a tank, comprising a pump and a drain pipe, wherein a gas medium is supplied so as to create a gas/liquid current and wherein the gas medium is entering the drain pipe together with the liquid from the pipe inlet.

By using, in addition to the pump arrangement with submerged pump, an extra, separate drain arrangement a relatively simple "stripping mode" is achieved. Thus, by supplying a gas medium to the drain pipe and allowing the gas medium to enter the drain pipe together with the liquid from the pipe inlet it is possible to remove a residual liquid residue - especially from the bottom of a tanker or if necessary from an equivalent land installation, where there is a question of corresponding large lifting heights - by means of a stationary arrangement with few or no moving parts submerged in the tank.

It is an object of the present invention to improve such extra, separate drain arrangement in order to achieve additional draining effect by supplying the gas medium at a selected level inside the drain pipe.

The process is characterised in that the gas medium is supplied to the gas/liquid current in the drain pipe via a gas supply conduit separately received in the pipe.

By receiving a gas supply conduit in the drain pipe and by supplying gas medium via said conduit to the gas/liquid current in the drain pipe, it is possible to apply to the current of gas/liquid that enters the pipe inlet additional lifting force at selected level or levels in the drain pipe, as may be required in each case. According to the invention by receiving the gas supply conduit separately in the drain pipe it is thus possible to effect discharge of the liquid residue from the countersinking in the bottom of the tank with an arrangement which has an especially simple design and which is without moving parts in the tank. This will also facilitate and simplify cleaning and maintenance.

By the supply of extra gas medium to the gas/liquid current in the drain pipe according to the invention there is obtained a modified gas/liquid mixture with a significant lower density than the specific gravity of the gas/liquid current entering the pipe inlet. This results in being able to transport the liquid by simple means a substantially greater height through the drain pipe in the form of a modified gas/liquid mixture.

A second important effect of the extra supply of gas medium to the gas/liquid current, in addition to the effect of the additional mixing together of gas and gas/liquid current, is that the more readily mobile gas medium will be exposed to an extra suction effect relative to the gas/liquid mixture and can thereby produce a greater speed of motion than the initial gas/liquid mixture. Accordingly, the gas medium can carry along portions of the gas/liquid mixture and thereby facilitate the transportation of the same.

A third important effect of the supply of extra gas

medium to the gas/liquid current is that the loss of friction in the drain pipe is reduced and with this a higher rate of flow can be achieved and thereby an increased lifting capacity.

Practical tests have shown that by means of providing additional suction effect at different levels the gas/liquid mixture can be lifted over heights which are the multiple of the practical lifting height of the initial gas/liquid mixture by the force of suction.

The process can for example be carried out in that the gas medium is supplied by pressure drop flow from the tank via passages in the pipe to the gas/liquid current in the pipe.

By this it is possible by means of the pump or the ejector to suck the gas medium (for example inert gas) from the tank itself directly into the gas/liquid current in the drain pipe by throttling the flow of gas to the drain pipe. Consequently such a gas flow or leaking in of gas into the gas/liquid current can be effected in a simple manner, without being dependent upon extra moving parts, such as valves and the like. This simple principle for the admixture of gas can simplify maintenance and cleaning of the arrangement to a significant degree. By pressing an extra pressure in the tank the gas medium can be supplied to the drain pipe with a certain excess pressure, in order thereby to further facilitate the lifting of the gas/liquid mixture in the drain pipe.

Alternatively the process can be carried out by feeding the gas medium to the gas/liquid current in the pipe via a separate gas supply conduit received in the pipe.

By this there is the possibility of employing an arbitrary gas medium, adapted according to the conditions, and to employ separately regulatable gas medium pressures and/or amounts of gas medium, controlled separately via the gas supply conduit and thereby independently of the gas pressure in the tank.

With an extra gas medium pressure in the current of gas flowing out from the separate gas supply conduit, one can obtain if desired an extra blast effect in addition to the suction effect itself which is achieved by means of the pump or the ejector. In other words an ejector can be employed at the lower end of the gas supply conduit in the instance one finds this necessary or current interest.

It is possible to effect the feeding of gas medium to the drain pipe both from the tank via openings in the drain pipe and from the extra gas supply conduit, with the possibility for separate regulation of the amount of gas and gas pressure via the gas supply conduit.

Alternatively the supply of gas medium can occur exclusively by means of the extra gas supply conduit.

The present invention also relates to a draining arrangement for draining a residue of liquid from the bottom of a tank comprising a drain pipe arranged between the tank bottom and a pump or ejector, which is arranged at a level substantially above the bottom of the tank and preferably above the top of the tank,

wherein gas medium is supplied in at least at one level between the bottom of the tank and the pump or the ejector to the current of gas/liquid.

The draining arrangement is characterised in that the gas supply openings are designed in a separate gas supply conduit which is arranged internally in the drain pipe."

Further features of the present invention will be evident from the following description having regard to the accompanying drawings, in which:

Fig. 1 shows a cross-section of a tank of liquid having a first draining arrangement for draining a major portion of the liquid in the tank and a second draining arrangement according to a first construction, for draining a residue of liquid from the bottom of the tank.

Fig. 2 shows on a larger scale a section of the second draining arrangement according to Fig. 1.

Fig. 3 shows in a cross-section corresponding to Fig. 1 another construction of the second draining arrangement.

Fig. 4 shows in a representation corresponding to Fig. 2 a section of the second draining arrangement according to Fig. 3.

Fig. 5 shows in a representation corresponding to Fig. 2 and 4 a modified solution of the construction of Fig. 3 and 4.

In Fig. 1 there is shown a tank 10 of a ship for reception of liquid. In connection with the tank there is shown a bottom 10a, a top 10b and the one 10c of two pairs of sides opposing in pairs. In the tank bottom 10a a local countersinking 11 is shown for the collection of a residue of liquid in the tank in a closing phase of the draining operation.

There is illustrated a first draining arrangement 12 of known construction for draining a major portion of liquid from the tank and a second draining arrangement 13 according to the invention for draining a liquid residue 14 from the tank. In the illustrated embodiment the two draining arrangements are shown as two separate units, but in practice the arrangements can be assembled in a coherent construction, with mutually independent modes of operation. In practice the arrangements can be employed separately or simultaneously, in the final phase of the draining operation, if the last-mentioned is preferred.

The draining arrangement 12 can be for example of a type corresponding to that shown in NO 123.115 and shall not be described further herein, the present invention exclusively relating to the second draining arrangement 13 for draining the liquid residue 14, which is left in the tank after the termination of the draining operation with the draining arrangement 12.

In fig. 1 a liquid residue 14 is shown which exceeds the top of the countersinking 11, while in Fig. 2 a considerably smaller liquid residue 14' is shown which is only

to be found in the countersinking 11 itself. In the countersinking 11 the lower portion of both the first and the second draining arrangement are received. The countersinking 11 is illustrated with a main bottom portion 11a, which cooperates with an intake 12a to the first draining arrangement 12. The countersinking is shown with a local bottom portion 11b submerged in relation to the main bottom portion 11a, which cooperates with a lower intake 13a to the second draining arrangement 13, as is best evident from Fig. 2.

The second draining arrangement 13 comprises a rigid drain pipe 15, which extends from a lower level just above the bottom portion 11b to an upper level to a displacement pump 16 (see Fig. 1). In the illustrated embodiment the displacement pump 16 is arranged above and outside the tank 10, but can if necessary be submerged in the tank, for example arranged in a cofferdam at the upper portion of the tank (not shown further).

In the drain pipe 15 the supply of gas medium is shown with arrows A in Fig. 1 from the tank 10 to the interior of the drain pipe 15 for different levels at a1 and a2 of the drain pipe. As required a single or more than the illustrated two levels can be employed for the supply of gas medium to the drain pipe. From the pump 16 a discharge conduit 17 extends to a storage container (not shown further), in which gas medium is separated from liquid medium. Alternatively the conduit 17 can lead to the same delivery location which the remaining contents of the tank are delivered to.

Instead of the displacement pump an ejector (not shown further) can for example be employed, which for example can be arranged above and outside the tank.

In Fig. 2 a lower portion of the drain pipe 15 is shown during operation of the pump 16, where the drain pipe below the level a1 is supposed to contain sucked in liquid having a specific gravity of for example 1 kg./dm^3 , while an overlying portion of the drain pipe above the level a1 is shown with a mixture of gas and liquid having a density of for example 0.75 kg./dm^3 , which is obtained by the supply of a throttled current of gas medium, as illustrated by the arrows A at the level a1. Correspondingly above a second level a2 a gas/liquid mixture can be obtained having a density of for example 0.3 kg./dm^3 achieved by the supply of a throttled current of gas medium as illustrated by the arrows A at the level a2 (Fig. 1). At further subsequent levels (not shown further) the density of the gas/liquid mixture can correspondingly be further reduced by the additional supply of throttled gas medium. Alternatively the whole quantity of gas medium can be supplied at one and the same level. Gas medium supply to the drain pipe is illustrated in Fig. 2 via two diametrically opposed throttle nozzle openings 19a, 19b at the level a1. corresponding throttle nozzle openings can be employed at the level a2. In practice an annular series of openings can be employed at one of the levels or at each level, instead of the two opposed openings illustrated. If desired the various openings can have different cross-sectional openings and/or different

directional paths in order to supply gas medium in different amounts and in a different manner so as to mix the gas medium with the liquid medium in the drain pipe in a different way.

In the top 10b of the tank there is shown a gas supply conduit 100 for feeding inert gas from a source of inert gas (not shown) via a regulating valve 100' to the interior of the tank. In a manner known *per se* it is possible with the supply of inert gas to build up a certain excess pressure (for example 0,1 bar) in the interior of the tank. By maintaining this excess pressure in the tank an equivalently increased pressure can be ensured against the liquid residue 14 or 14' and against the column of liquid in the drain pipe at the lower end of the drain pipe.

In Fig. 3 and 4 a draining arrangement 13' is shown according to an alternative construction, where the substantial departure relative to the construction in Fig. 1 and 2 consists in the drain pipe 15' being illustrated without throttle nozzle openings 19a, 19b, as shown in Fig. 2, while gas medium is fed separately through an extra gas medium conduit 21 which is arranged internally in the drain pipe 15', which is unperforated. In Fig. 3 the conduit 21 is shown in broken lines.

One has the possibility of placing the gas medium conduit centrally or eccentrically in the drain pipe and if desired with a helical contour or with other contours, according to need, in order to bring about various flow effects for the current of gas/liquid and the gas medium fed internally in the drain pipe and thereby different mixing effects between the supply of gas medium and the current of liquid in the drain pipe and different flow paths for the gas/liquid mixture in the drain pipe. Correspondingly the gas discharge openings can be arranged in different angular positions relative to the drain pipe in order to obtain further different flow effects and mixing effects internally in the drain pipe.

In the embodiment illustrated in Fig. 4 a gas medium conduit 21 is shown having a closed lower end 21a and having throttle nozzle openings 22a, 22b disposed at a level a1. By regulating the supply of gas medium with a regulating valve 23 in the conduit 21 gas medium can be fed in different quantities and with different pressures as required.

Alternatively, as shown in Fig. 5, or in combination with the construction which is illustrated in Fig. 3 and 4, the lower end of the gas medium conduit 21' is provided with an ejector 25 which forms an ejector effect internally in the drain pipe 15' at a level a1 at the lower end 15a of the pipe 15'. It will also be possible to employ the solution as shown in Fig. 5 in combination with the solution as illustrated in Fig. 1 and 2. In the illustrated embodiment the gas medium is discharged into the drain pipe 15' in a concentrated stream of compressed air lowermost in the drain pipe, preferably in a compressed air stream directed vertically upwards from an upwardly directed outlet 25a at the lower end of the gas medium conduit 21. By arranging the lower end 21a of

the conduit 21 at a level at the lower end of the drain pipe 15' the ejector effect can be exerted just at or just above the liquid residue 14' at the intake opening of the drain pipe and thereby produces a significant change in the density of the transport medium (the gas/liquid mixture) already at a level a1 at the lower end of the drain pipe and at the same time brings about a significant extra suction effect at the lower intake opening of the drain pipe. By this a large portion or if necessary the main portion or the whole amount of the gas medium can be supplied at the lower end of the drain pipe. As mentioned the solution with the ejector effect can be employed together with overlying (downstream) throttle nozzle openings in the drain pipe 15 (Fig. 1 and 2) and/or overlying (downstream) throttle nozzle openings in the extra gas supply conduit 21 (Fig. 3 and 4). By remote control of gas pressure and gas amounts the amount of gas supply and the ejector effect can be separately regulated as required at the lower end of the drain pipe.

Claims

1. Process for draining a liquid residue (14, 14') from the bottom (10a) of a tank (10) via a drain pipe (15), which extends from a location near the tank bottom and is connected to a pump (16) or ejector which is arranged at a level substantially above the upper level of the liquid residue (14, 14') and preferably above the top (10b) of the tank, the pump (16) or ejector establishing a gas/liquid current in the drain pipe (15) between the bottom of the tank and the pump (16) or ejector, **characterised** by submerging an open bottom end (13a) of the drain pipe (15) in said liquid residue (14, 14') at the bottom (10a) of the tank (10) and, while establishing said gas/liquid current in the drain pipe (15), letting a gas medium, which is contained in the tank (10) above the upper level of the liquid residue (14, 14'), be sucked into the drain pipe (15) through gas inlet openings (19a, 19b) arranged in the drain pipe wall at one or more distinct levels (A1, A2) above the upper surface of said liquid residue (14, 14') in order to mix this gas medium with said liquid current passing through said drain pipe (15).
2. Process according to claim 1, **characterised** by submerging the open end (13a) of the drain pipe in said residue (14') in a countersink (11) arranged in the bottom (10a) of the tank (10).
3. Draining arrangement (13') for draining a liquid residue (14, 14') from the bottom (10a) of a tank (10), comprising a drain pipe (15) extending from a location near the tank bottom (10a) and a pump (16) or ejector, which is arranged at a level substantially above the surface level of the residue (14, 14') in the tank (10) and preferably above the top (10b) of the tank, the pump (16) or the ejector being arranged to establish a gas/liquid current in the drain pipe (15) between the bottom of the tank and the pump (16) or the ejector, **characterised** in that an open bottom end (13a) of the drain pipe (15) is arranged near the bottom of the tank to be submerged in said liquid residue (14, 14') and that the drain pipe (15) has gas inlet openings (19a, 19b) in its pipe wall at one or more distinct levels (A1, A2) above the upper surface of the liquid residue (14, 14') in the tank for letting a gas medium, which is contained in the tank (10) above the upper level of the liquid residue (14, 14'), be sucked through said gas inlet openings (19a, 19b) into the drain pipe to be mixed with said gas/liquid current passing through said drain pipe (15).
4. Draining arrangement according to claim 3, **characterised** by a countersink (11) which is arranged in the bottom (10a) of the tank (10) and into which the open bottom end (13a) of the drain pipe (15) extends.

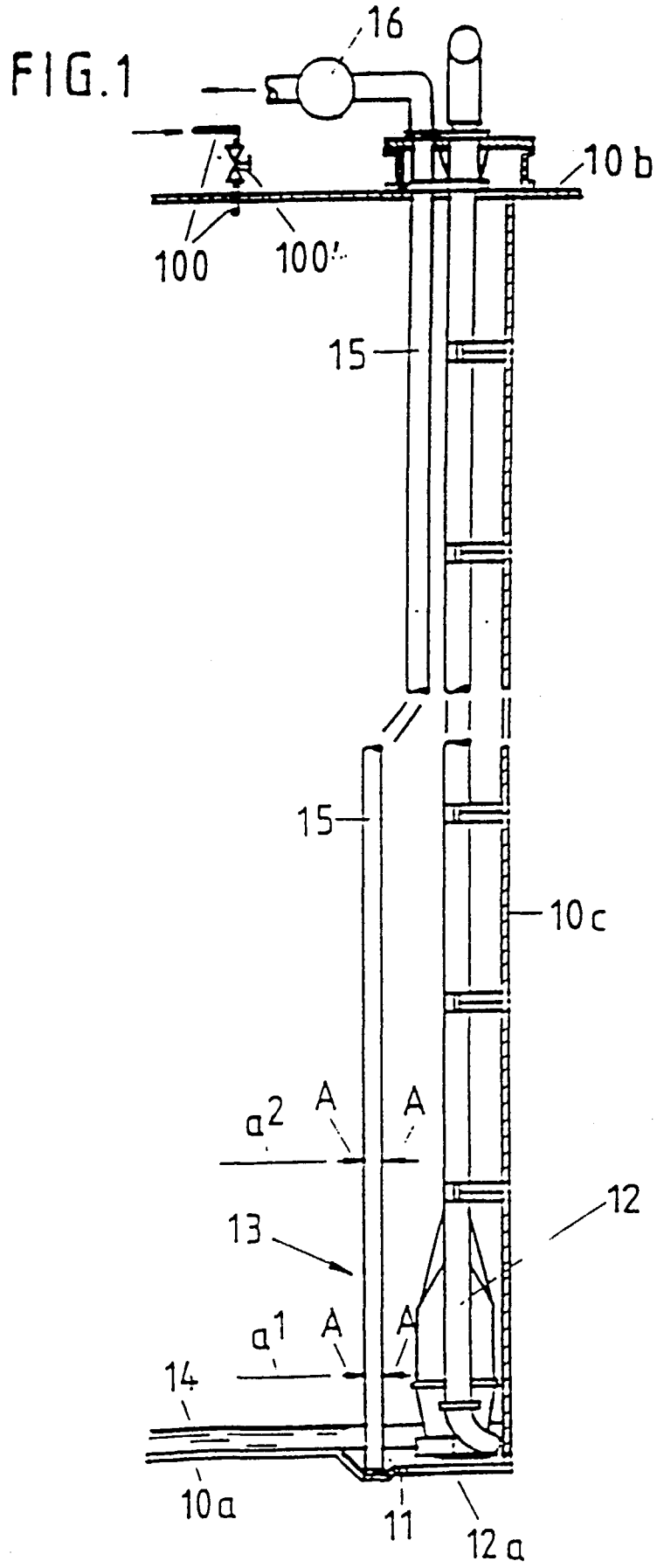
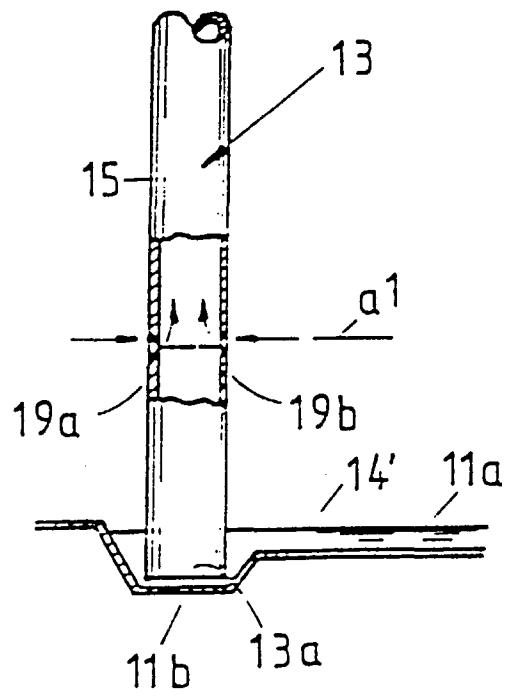

FIG. 2



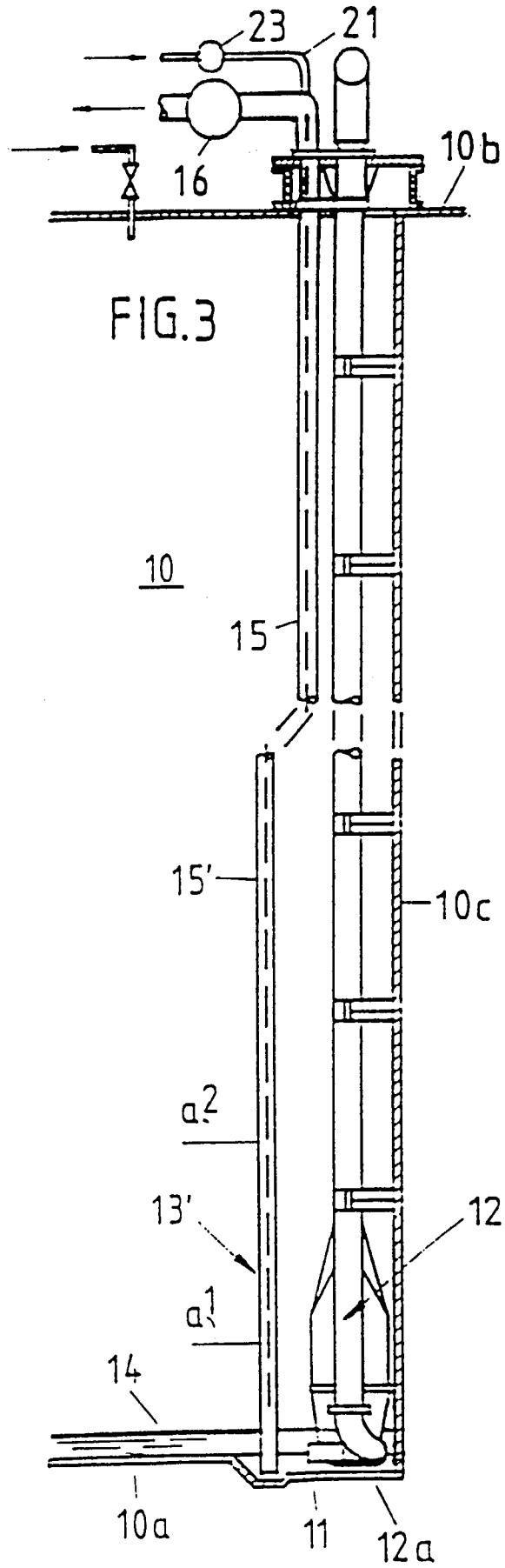

FIG. 4

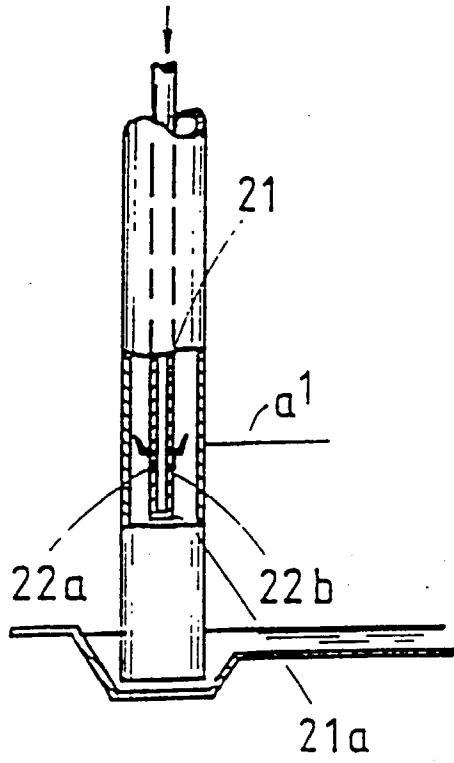

FIG. 5

