



(No Model.)

4 Sheets—Sheet 2.

R. W. BAYLEY.  
FORGING MACHINE.

No. 429,080.

Patented May 27, 1890.

FIG. 2

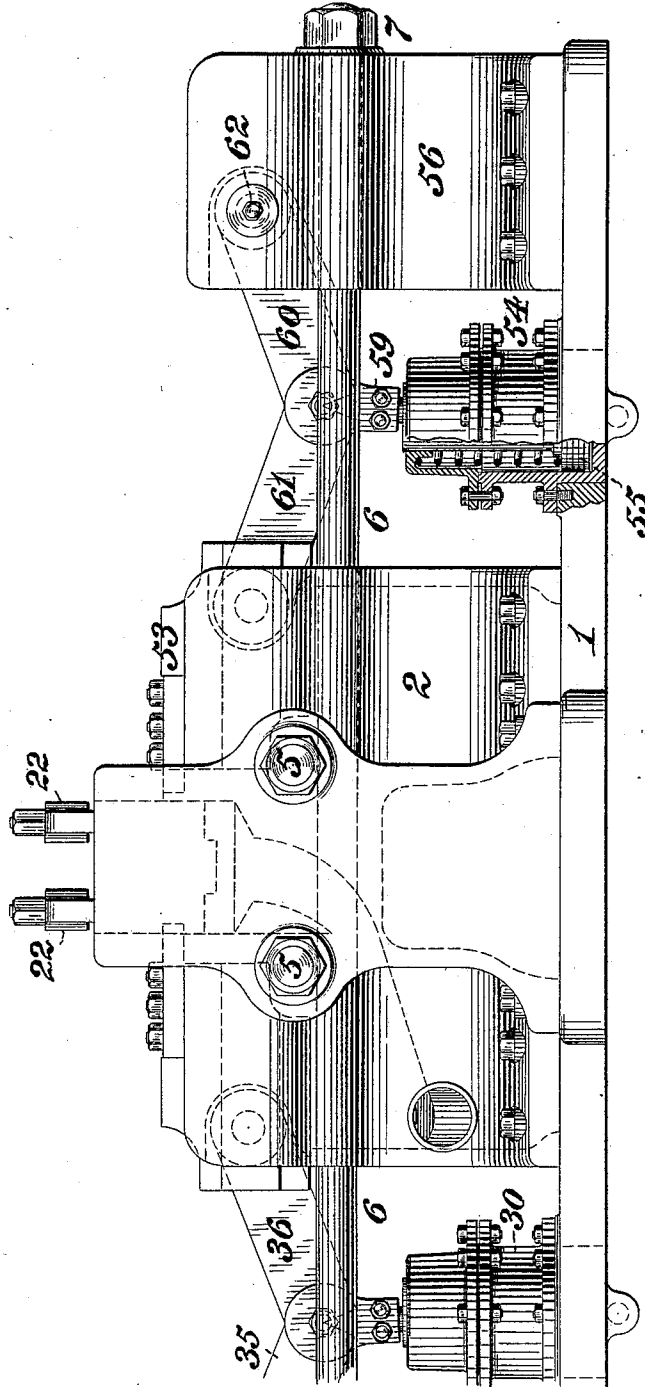

WITNESSES:  
*R. H. Whittelsey*  
*F. E. Gaither*

INVENTOR,  
*Richard W. Bayley*  
by *John W. Bell*,  
Att'y.

(No Model.)

4 Sheets—Sheet 3.

R. W. BAYLEY.  
FORGING MACHINE.

No. 429,080.

Patented May 27, 1890.

FIG. 3

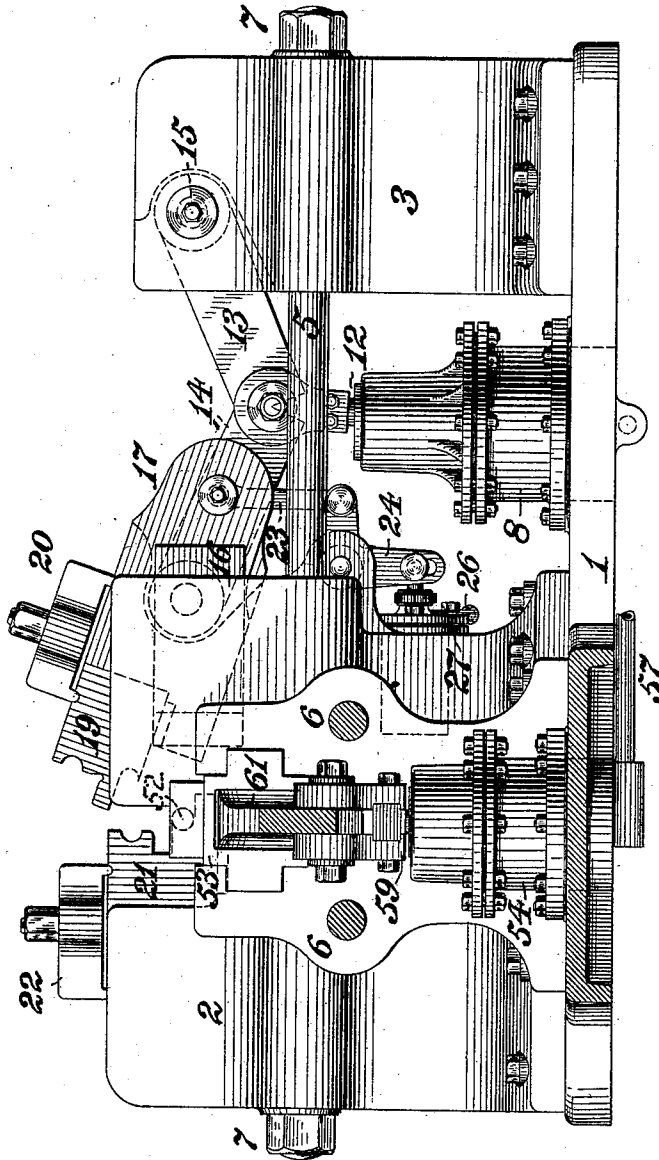

WITNESSES:

*R. H. Whittsey*  
*F. E. Gaither*

INVENTOR,

*Richard W. Bayley,*  
*by J. Howard Bell,*  
Att'y.

R. W. BAYLEY.  
FORGING MACHINE.

No. 429,080.

Patented May 27, 1890.

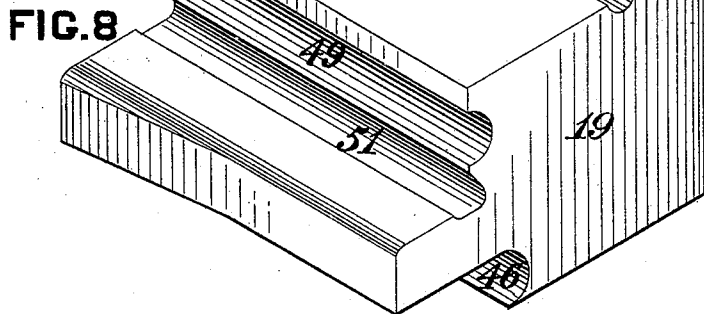
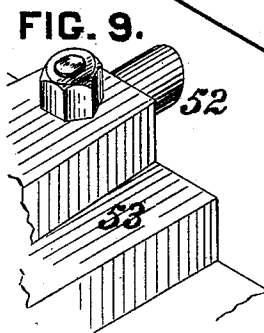
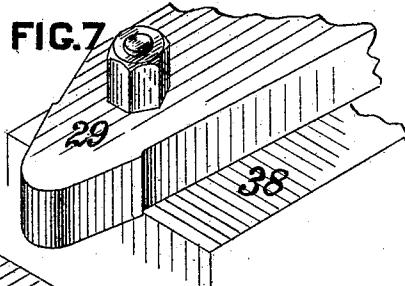
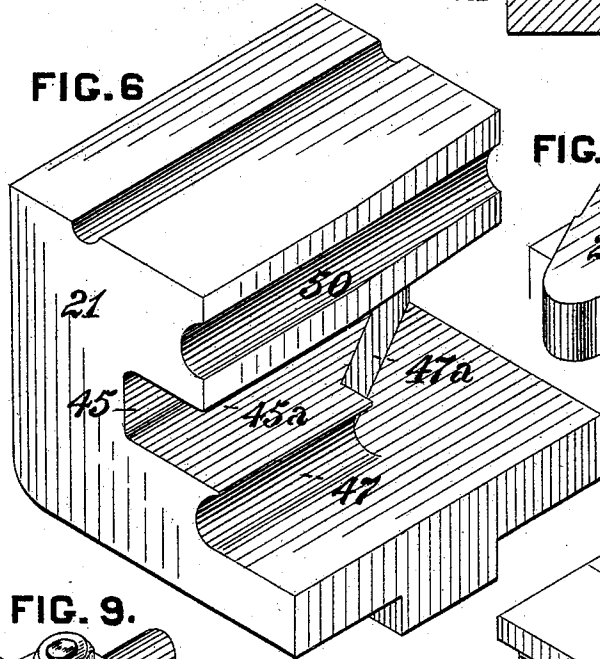
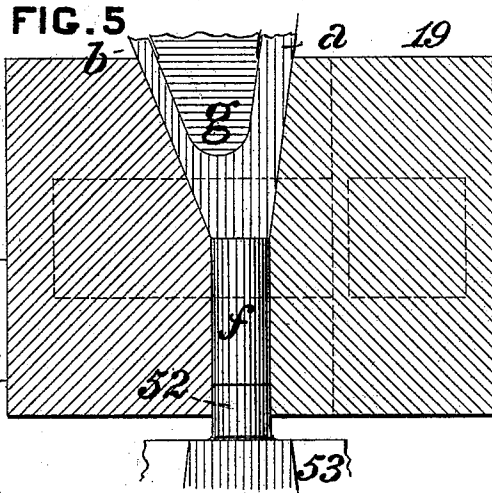
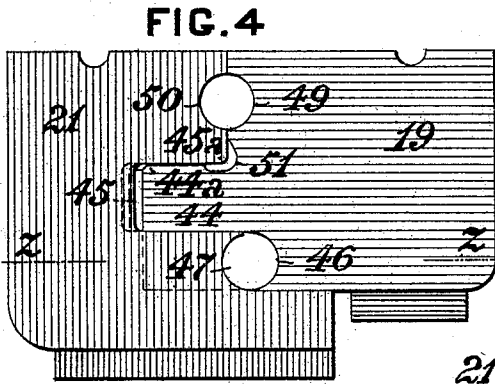

WITNESSES:

*R. W. Whittelsey*  
*F. C. Gaither*

INVENTOR,

*Richard W. Bayley,*  
*by J. Mendenhall,*  
Att'y.

# UNITED STATES PATENT OFFICE.

RICHARD W. BAYLEY, OF PITTSBURG, PENNSYLVANIA, ASSIGNOR TO THE NATIONAL HOLLOW BRAKE BEAM COMPANY, OF CHICAGO, ILLINOIS.

## FORGING-MACHINE.

SPECIFICATION forming part of Letters Patent No. 429,080, dated May 27, 1890.

Application filed March 15, 1890. Serial No. 344,001. (No model.)

*To all whom it may concern:*

Be it known that I, RICHARD W. BAYLEY, a citizen of the United States, residing at Pittsburg, in the county of Allegheny and State of Pennsylvania, have invented or discovered a certain new and useful Improvement in Forging-Machines, of which improvement the following is a specification.

My present invention is an improvement upon that set forth in my application, Serial No. 340,242, filed February 13, 1890; and its object is to provide means whereby the end of the forging may be trued and finished and the filling of the die-cavity with metal be insured when the dies are brought together, thereby more perfectly welding the members to be connected and promoting uniformity and smoothness of shape and finish.

To this end my invention, generally stated, consists in the combination of a frame or bed, a fixed and a movable die mounted thereon, fluid-pressure mechanism for actuating the movable die through the intervention of toggle-joint levers, and a supplemental end finishing-die actuated by fluid-pressure mechanism.

The improvement claimed is hereinafter fully set forth.

In the accompanying drawings, Figure 1 is a plan or top view of so much of a forging-machine as is necessary to illustrate my invention; Fig. 2, a side view in elevation, looking from the left of Fig. 1; Fig. 3, a transverse section at the line  $x x$  of Fig. 1, looking toward the top of said figure; Fig. 4, an end view of the fixed die and the opposite movable die; Fig. 5, a horizontal section through the same at the line  $z z$  of Fig. 4; Fig. 6, a view in perspective of the fixed end die; Fig. 7, a similar view of the fillet-die; Fig. 8, a similar view of the movable end die, and Fig. 9 a similar view of the supplemental end finishing-die.

My invention is herein illustrated and will be described in connection with a machine according substantially in other particulars with that set forth in my application, Serial No. 340,242 aforesaid, by which the ends of a body and truss-bar are welded to interposed filling-pieces, journals formed and finished

upon the ends of the forging, and the inner ends of the filling-pieces suitably filleted. Under my present invention the above functions are similarly performed by corresponding forging mechanism, and, in addition, the finishing of the ends of the forging is provided for and the filling of the die-cavity completely with metal insured during the welding operation. The mechanism for effecting the functions first recited, not being claimed as of my present invention, and being, moreover, fully set forth in my application aforesaid, will not be herein described further than will serve to explain the relation thereto of that which forms the subject of my present application.

The base-plate 1 carries, as in my prior application, a die-block 2 and two abutment-blocks, one of which 3 only is shown in the drawings, said abutment-blocks being connected to the die-block by tension-rods 5 6, provided with nuts 7. The welding and shaping of the ends of the forging is effected by and between a fixed end die 21, secured to the die-block 2, and a movable end die 19, fixed upon a carrier 17, journaled in die-slides fitted to reciprocate on the die-block 2, the fixed and movable dies being suitably grooved on their adjacent faces, and the movable die being actuated, through toggle-lever connections, by the piston of a fluid-pressure cylinder 8, fixed to the base-plate between the die-block 2 and abutment-block 3. The fillets at the inner ends of the filling-pieces of the forging are formed by a fillet-die 29, secured upon a die-slide 38, which is reciprocated in guides on the die-block 2, through toggle-joint connections, by the piston of a fluid-pressure cylinder 30.

The working-face of the fixed die 21 is provided with a preliminary forging and welding groove 47 and finishing-groove 50, and the corresponding face of the opposite movable die 19 with a preliminary forging and welding groove 46 and a finishing-groove 49. In my prior application the metal of the dies 19 and 21 is prolonged beyond the ends of the grooves 46 and 47, so as to close said grooves and the die-cavity which they form at the outer end, except through the extent of a narrow vertical central opening or discharge

passage between the meeting faces of the dies when the movable die is closed upon the fixed die, said passage being outwardly flared or tapered and serving for the ejection of any surplus metal endwise in the form of a thin central fin. It will be seen that with such construction the end of the journal on the forging is not completely and smoothly finished, and in the event of there being an insufficiency of metal between the dies the die-cavity will not be entirely filled. In order to obviate the objections above indicated, the grooves 46 and 47 are, under my present invention, extended to the ends of the dies 19 and 21, so as to present an open-ended die-cavity when the working-faces of said dies are brought together and a supplemental end finishing-die is fitted to enter and traverse longitudinally in the die-cavity. The supplemental end finishing-die 52, which is of cylindrical form and of diameter proper to fit neatly in the die-cavity, has its outer or working-face preferably substantially plane and perpendicular to its axis and is secured upon a die-slide 53, which is fitted to reciprocate in guides on the die-block 2, in line axially with the die-cavity formed by the grooves 46 and 47 when the die 19 is brought up to the die 21. A fluid-pressure cylinder 54, fitted with a trunk-piston 55, is secured to the base-plate 1 between the die-block 2 and a supplemental abutment-block 56, which is bolted to the frame at a proper distance from the die-block 2, and is connected to the latter by the tension-rods 6, which are suitably prolonged for that purpose. The cylinder 54 is provided with a pipe 57 for the admission and exhaust of fluid under pressure to and from the lower side of the piston 55, and with a helical spring bearing upon the upper side of the piston to effect the downward traverse thereof, as from time to time required. The piston 55 is coupled by a connecting-rod 59 to the adjacent ends of a pair of toggle-joint levers 60 61, the opposite end of the lever 60 being journaled on a pin 62, fixed in the abutment-block 56, and the opposite end of the lever 61 being coupled to the die-slide 53.

In operation the pieces of metal to be forged having been assembled at a welding-heat at the portions to be united are located and held in proper positions upon the die-block 2, as indicated in dotted lines in Fig. 1, and the welding of one end and preliminary shaping of the cylindrical portion of the journal thereat is effected by the traverse of the movable die 19, under the pressure imparted thereto from the piston of the fluid-pressure cylinder 8, through the toggle-joint-lever connections. The fillets at the inner end of the welded and forged portion are formed by the die 29, upon the application of pressure thereto from the piston of the cylinder 30, and the outer end of the forging is truly and smoothly finished by the supplemental end finishing-die 52, which is forced

into the end die-cavity included between the walls of the grooves 46 and 47 by the pressure acting on the piston 55 of the cylinder 54, with the increment due to the toggle-joint connections 60 and 61. The end pressure exerted by the die 52 acts further to laterally expand or swage the metal in the die-cavity against the walls of the same in the event of the bulk of metal being insufficient to entirely fill the cavity throughout the length of the cylindrical portion of the forging, thereby insuring more perfect connection of the parts and uniformity of shape and finish in the different forgings produced. Upon the retraction of the movable dies the periphery of the cylindrical portion of the forging may be subjected to a finishing-pressure in the grooves 49 and 50, as provided for in my prior application.

I claim as my invention and desire to secure by Letters Patent—

1. In a forging-machine, the combination of a frame or bed, a die fixed thereon, a die fitted to reciprocate thereon toward and from the fixed die, the fixed and movable dies having grooves in the same plane on their working-faces, a fluid-pressure cylinder and piston, toggle-joint levers coupled to said piston and to the movable die, a supplemental end finishing-die fitted to reciprocate in line axially with and traverse into the cavity formed by the grooves of the fixed and movable die when said dies are brought together, a second fluid-pressure cylinder and piston, and toggle-joint levers coupled to said piston and to the supplemental end finishing-die, substantially as set forth.

2. In a forging-machine, the combination of a frame or bed, a fixed die, a die movable toward and from the fixed die, the fixed and movable dies having substantially semi-cylindrical grooves in the same plane on their working-faces, a fluid-pressure cylinder and piston, toggle-joint levers coupled to said piston and to the movable die, a cylindrical supplemental end finishing-die having a substantially plane working-face and fitted to reciprocate in line axially with and traverse into the cavity formed by the grooves of the fixed and movable dies when said dies are brought together, a second fluid-pressure cylinder and piston, and toggle-joint levers coupled to said piston and to the supplemental end finishing-die, substantially as set forth.

3. In a forging-machine, the combination of a frame or bed, a fixed die, a die movable toward and from the fixed die, the fixed and movable dies having grooves in the same plane in their working-faces, a fluid-pressure cylinder and piston, toggle-joint levers coupled to said piston and to the movable die, a second movable die fitted to reciprocate at an angle to the traverse of the first movable die, a second fluid-pressure cylinder and piston, toggle-joint levers coupled to

said piston and to the second movable die, a  
supplemental end finishing-die fitted to re-  
ciprocate in line axially with and traverse  
into the cavity formed by the grooves of the  
5 fixed and the first movable die when said  
dies are brought together, a third fluid-pres-  
sure cylinder and piston, and toggle-joint le-  
vers coupled to said piston and to the supple-

mental end finishing-die, substantially as set  
forth.

In testimony whereof I have hereunto set  
my hand.

RICHARD W. BAYLEY.

Witnesses:

J. SNOWDEN BELL,  
R. H. WHITTLESEY.