

Feb. 7, 1928.

1,658,487

A. J. JONES

CIGAR BOX

Filed March 8, 1926

Fig. 1.

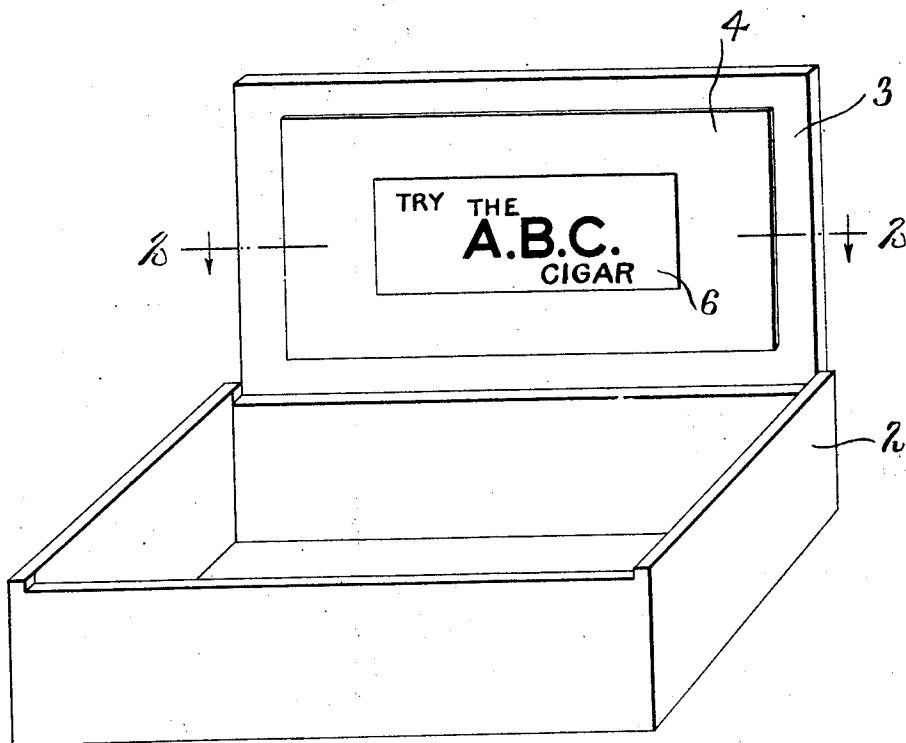
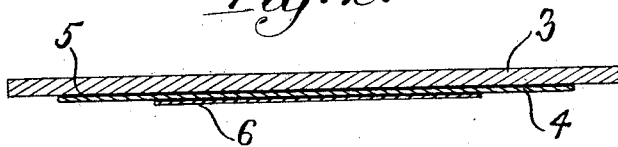

Fig. 2.



Inventor:

Aldred J. Jones

by E. D. Chadwick atty.

UNITED STATES PATENT OFFICE.

ALDRED J. JONES, OF CHICAGO, ILLINOIS.

CIGAR BOX.

Application filed March 8, 1926. Serial No. 93,016.

My invention relates to cigar boxes, and is intended to provide a cigar box which will be capable of serving as a humidor to prevent its contents from becoming too dry. A cigar box embodying my invention is illustrated in the accompanying drawing, in which—

Figure 1 is a isometric perspective of the box with the cover open, and

Figure 2 is a section on the line 2—2 in Figure 1.

In the drawing, 2 indicates a cigar box having the usual hinged cover 3, to the inner face of which is attached a sheet 4 of blotting paper or other inexpensive material which is capable of readily absorbing water. Between the sheet 4 and the cover 3 is interposed a layer 5 of some material which is impervious to water, or substantially so, and therefore prevents the water absorbed by the sheet 4 from reaching the cover 3 and causing it to warp. Preferably the layer 5 consists of a glue or cement which is insoluble in water when dry, and which also serves as a means of attachment of the sheet 4 to the cover 3.

Any desired printing matter may be applied to the exposed surface of the sheet 4, and preferably this is done by means of a label such as 6, on which the printed matter appears and which is attached to the sheet 4 by an adhesive like that constituting the layer 5. The use of such a label has the advantage that the water contained in that portion of the sheet 4 which is covered by the label is prevented from evaporating except as it is drawn by capillary attraction into the exposed portion of said sheet 4, so that by suitably proportioning the areas of the sheet 4 and the label 6 the rate of evaporation may be so regulated as to

prevent the contents of the box 2 from becoming excessively moist.

The cigar box above described may be packed with cigars, shipped and sold in the usual way, and its contents may be kept as moist as the user may wish by applying a suitable quantity of water to the sheet 4 from time to time. It will be seen that the added parts which enable this result to be obtained are few and inexpensive, so that the box has the utility of a humidor without being materially increased in cost.

For example, the present invention can be utilized with practically no increased cost merely by substituting a sheet of blotting paper for the paper normally covering the inside of the lid of the box, the application of the blotting paper being done by the same machines and in the same manner.

I claim:—

1. As an article of manufacture, a cigar box provided on the inner face of its cover with a sheet of absorbent material, said sheet being connected directly to the cover by a layer of material impervious to water and being so arranged as to permit the closing of the cover when the box is filled.

2. As an article of manufacture, a cigar box provided on the inner face of its cover with a sheet of absorbent material directly and permanently attached thereto by a layer of material impervious to water, the outer face of the absorbent sheet being partly covered by a sheet of material impervious to water which limits the exposed area of the absorbent sheet, and the collective attached sheets being sufficiently thin to permit the closing of the cover when the box is filled.

Signed at Boston, Massachusetts this 6th day of March, 1926.

ALDRED J. JONES.