

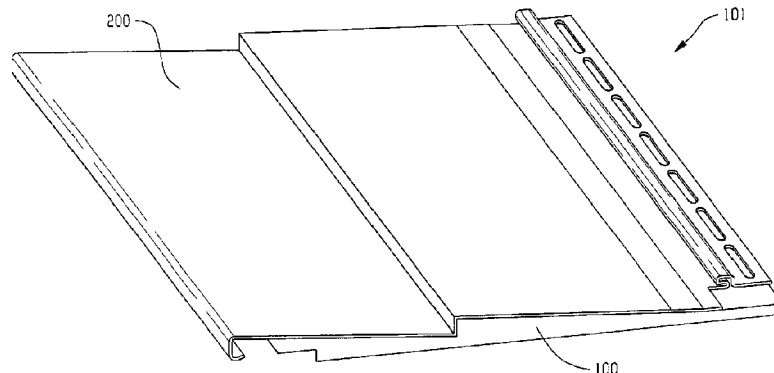

(22) **Date de dépôt/Filing Date:** 2018/01/18
(41) **Mise à la disp. pub./Open to Public Insp.:** 2018/07/18
(45) **Date de délivrance/Issue Date:** 2020/03/10
(30) **Priorités/Priorities:** 2017/01/18 (US62/447,548);
2017/07/06 (US62/529,110)

(51) **Cl.Int./Int.Cl. E04F 13/18** (2006.01),
E04F 13/16 (2006.01)
(72) **Inventeurs/Inventors:**
CULPEPPER, PATRICK M., US;
BEACH, RYAN, US
(73) **Propriétaire/Owner:**
PROGRESSIVE FOAM TECHNOLOGIES, INC., US
(74) **Agent:** PIASETZKI NENNIGER KVAS LLP

(54) **Titre : PANNEAU DE REVETEMENT ET ASSEMBLAGE**
(54) **Title: SIDING PANEL AND ASSEMBLY**



(57) **Abrégé/Abstract:**

A composite siding panel mountable on an exterior wall of a building includes a backing member and a siding member attached to the backing member, wherein the first side edge of the siding member overhangs the first side edge of the backing member, and the second side edge of the siding member is aligned with or positioned contiguously with the second side edge of the backing member. An adhesive coating joins the front face of the backing member to the rear face of the siding member. The adhesive coating runs substantially from the first side edge of the backing member to the second side edge thereof. The backing member can be composed of closed-cell expanded foam or wire-fabricated foam, and the siding member can be formed from vinyl, polypropylene, aluminum, steel, fiberglass, engineered wood, or fiber cement. A siding assembly including a plurality of composite siding panels adjacently mountable on an exterior wall of a building is also disclosed.

ABSTRACT OF THE DISCLOSURE

A composite siding panel mountable on an exterior wall of a building includes a backing member and a siding member attached to the backing member, wherein the first side edge of the siding member overhangs the first side edge of the backing member, and the second side edge of the siding member is aligned with or positioned contiguously with the second side edge of the backing member. An adhesive coating joins the front face of the backing member to the rear face of the siding member. The adhesive coating runs substantially from the first side edge of the backing member to the second side edge thereof. The backing member can be composed of closed-cell expanded foam or wire-fabricated foam, and the siding member can be formed from vinyl, polypropylene, aluminum, steel, fiberglass, engineered wood, or fiber cement. A siding assembly including a plurality of composite siding panels adjacently mountable on an exterior wall of a building is also disclosed.

15

TITLE: SIDING PANEL AND ASSEMBLY

BACKGROUND

5 The present disclosure relates to a composite siding panel for an exterior wall of a building such as a house. Methods and processes for making and/or using such siding panels are also disclosed. In particular, the present disclosure provides for a siding panel including a siding member attached to a foam backing member. The front of the foam backing member includes an adhesive. The side edges of the siding member and the backing member are positioned relative to each other so as to eliminate the adhesive gap present in prior composite siding panels. Elimination of the adhesive gap eliminates undesirable buckling and stretching that can occur in such siding systems due to sun exposure, and simplifies the installation process.

10 Composite siding panels are known in the art. Vinyl siding is a popular choice because it is easily cleaned and it is resistant to deterioration. It may also be easily installed around windows and doors. Moreover, it may be produced in a variety of shapes and colors by known extrusion and molding processes at a relatively low cost per sheet or panel.

15 In many traditional composite siding panels, a vinyl siding member is attached to a foam backing member. Adhesive is applied to the front of the foam backing member for securing the backing member to the siding member. However, the adhesive usually terminates two to three inches from the vertical edges of the siding member. With such siding systems, an adhesive gap (i.e., a zone of no adhesive) of about five to six inches results between the backing members of adjacent siding panels.

20 The presence of such an adhesive gap can cause some problems. First, vinyl siding members have high coefficients of expansion and contraction, especially when exposed to heat such as from sun exposure. This can cause buckling and stretching of the vinyl siding member in the adhesive gap, resulting in an unacceptable, uneven, unsightly exterior surface. This may be known as "fish mouth", and can be caused by excessive heat, resulting in the vinyl warping

25
30

away from flat when post-formed. Another condition known as “dimpling” is a visual defect that is most visible when the vinyl siding is a dark color. In addition, the vertical edges of adjacent vinyl siding members often do not lay flat, due to sun exposure or improper manufacturing, handling, or installation. This can permit water, dirt, and debris, as well as air infiltration, through the siding and against the exterior wall that is supposed to be protected by the siding. It would be desirable to provide composite siding panels that allow for simple production and easy installation without the disadvantages of prior siding systems, such as the presence of adhesive gaps.

10

BRIEF DESCRIPTION

Disclosed in various embodiments herein are composite siding panels comprising a backing member and a siding member. The backing member has a front face, a rear face opposite the front face thereof, and longitudinally-extending first and second side faces. Rear side edges are present at the intersection of the rear face with each side face, and front side edges are present at the intersection of the front face with each side face. The siding member has a front face, a rear face opposite the front face thereof, and longitudinally-extending first and second side edges. The rear face of the siding member is in overlying relationship with and attached to the front face of the backing member via an adhesive coating. The adhesive coating is located between the siding member and the backing member, and runs substantially from the first front side edge of the backing member to the second front side edge thereof. The first side edge of the siding member extends outwardly beyond the first front side edge / first side face of the backing member to create an overhang, and the second side edge of the siding member is aligned with the second front side edge / second side face of the backing member. Put another way, the second side edge of the siding member is positioned contiguously with the second front side edge / second side face of the backing member.

30 In some embodiments, the adhesive coating on the front face of the backing member can also run substantially from a top front edge of the front face

to a bottom front edge of the backing member. In other embodiments, the adhesive coating also extends substantially from a bottom front edge of the backing member to a top edge of the siding member.

5 In particular embodiments, the adhesive on the front face of the backing member is discontinuous and is in the form of one or more beads, ribbons, dots, or swirls. In other embodiments, the adhesive coating is continuous and substantially covers the front face of the backing member from the first front side edge to the second front side edge of the backing member and from a top front edge to a bottom front edge of the backing member. Where complete coverage
10 of the front face of the backing member is desired, the adhesive can be applied by, for example, a roll coater or a curtain coater.

The siding member can overhang the backing member by at least $\frac{3}{8}$ inch (0.375 inches), or in other words the overhang can have a width of at least $\frac{3}{8}$ inch. In particular embodiments, the overhang is at least 0.375 inches up to about
15 1.25 inches.

The rear face of the backing member should be substantially planar, so that the composite siding panel is mountable on the exterior wall of a building. The first and second side faces of the backing member may also be substantially planar, and may be substantially parallel to each other. The rear face of the
20 backing member can include drainage grooves which are operable to remove water from a surface of the exterior wall.

In certain embodiments, the backing member is shape-molded and composed of closed-cell expanded foam. In other embodiments, the backing member is formed from wire-fabricated foam. The siding member may be formed
25 from vinyl, polypropylene, aluminum, steel, fiberglass, engineered wood, or fiber cement.

The backing member may have one or more contours defined therein and the siding member may have one or more complementary contours defined therein.

30 The siding member can include a nailing hem proximate a top end thereof. The nailing hem has a plurality of apertures therein for securing the composite

siding panel to an exterior wall of a building. In particular embodiments, the nailing hem runs from the first side face of the siding member to short of the second side face thereof. In certain constructions, the nailing hem runs from the first side face of the siding member to about 2 inches short of the second side face thereof, such that a gap is present between the nailing hem and the second side face. Alternatively described, the top edge of the siding member (i.e. the nailing hem) is shorter than the bottom edge / face of the siding member.

A bottom face of the siding member can include one or more drainage holes therein. A top end of the backing member can extend upwardly beyond a top end of the siding member. The backing member can include a laterally-extending relief channel in the rear face thereof proximate a bottom end thereof. The relief channel can run from the first rear side edge to the second rear side edge of the backing member. The relief channel is shaped to fit the top end of the backing member. Put another way, the relief channel is configured to engage the top end of a longitudinally adjacent backing member.

In certain embodiments, the siding member includes a locking flange proximate a top end thereof and a locking lip proximate a bottom end thereof. The locking flange may be complementary in shape to the locking lip and may be configured to operably engage with the locking lip of a longitudinally adjacent siding member. The locking flange may run from the first side face of the siding member to short of the second side face thereof, similar to the nailing hem.

In some embodiments, an adhesive layer can be located on a rear surface of the overhang. The adhesive layer may comprise an acrylic adhesive.

Also disclosed herein are siding assemblies comprising including a plurality of composite siding panels as described above. Also disclosed are kits that include a composite siding panel as described above, as well as a double-sided tape. The double-sided tape comprises a foam core with two opposing surfaces; and an adhesive layer on each of the two opposing surfaces. It has been found that a tape with a foam core works better than a tape with a sheet core.

These and other non-limiting characteristics are more particularly described below.

BRIEF DESCRIPTION OF THE DRAWINGS

5 The following is a brief description of the drawings, which are presented for the purposes of illustrating the exemplary embodiments disclosed herein and not for the purposes of limiting the same.

FIG. 1 is a right side perspective view of a composite siding panel according to the present disclosure. The composite siding panel includes a siding member and a backing member. The overhang is on the far side of the panel.

10 **FIG. 2A** is a front perspective view of the composite siding panel of **FIG. 1**. **FIG. 2B** is a rear perspective view of the composite siding panel of **FIG. 1**. The left side edge of the siding member extends outwardly beyond the left front side edge / left side face of the backing member to create an overhang, and the right side edge of the siding member is aligned with the right front side edge / right side face of the backing member.

15 **FIG. 3A** is a side view of a siding member according to the present disclosure. The siding member includes contours that are complementary to the contours of the backing member. **FIG. 3B** is a side view of a backing member according to the present disclosure. The backing member includes contours that are complementary to the contours of the siding member.

20 **FIG. 4** is a left front perspective view of the composite siding panel of **FIG. 1**. The left side edge of the siding member extends outwardly beyond the left side face of the backing member (indicated by dotted line) to create an overhang. The right side edge of the siding member is aligned with the right front side edge / right side face of the backing member. A small portion of the front face of the backing member is visible behind the siding member where the nailing hem of the siding member runs short of the second side edge thereof.

25 **FIG. 5** is a front view of the composite siding panel of **FIG. 1**. Solid lines indicate the perimeter of the siding member. Dashed lines indicate the perimeter of the portion of the backing member that is behind the siding member. The top

of the backing member is also visible above the siding member. The siding member includes a cutout along only the first side edge of the siding member proximate the top end thereof, such that a small portion of the front face of the backing member is visible behind the siding member.

5 **FIG. 6** is another front view showing different details of the composite siding panel of **FIG. 1**. Again, solid lines indicate the perimeter of the siding member, and dashed lines indicate the perimeter of portions of the backing member behind the siding member. The shaded area indicates where the placement of adhesive on the front face of the backing member starts and stops.

10 **FIG. 7** is a front view of a siding assembly according to the present disclosure comprising two composite siding panels placed side-to-side adjacent one another with the backing members abutting one another (i.e., foam on foam contact). The solid lines indicate the perimeters of the siding members, and dashed lines indicate the locations of portions of the backing members behind the siding members. The shaded areas indicate where the placement of adhesive starts and stops on the front faces of the backing members. No adhesive gap is present between the backing members of the two adjacent siding panels.

15 **FIG. 8A** is a side view of a siding assembly comprising two composite siding panels placed laterally adjacent one another. The arrows indicate the direction that each siding panel moves in order to operably engage with the other siding panel. **FIG. 8B** is another side view of the siding assembly of **FIG. 8A** with the two composite siding panels engaging one another. In particular, a locking flange of the siding member of the lower siding panel operably engages with a locking lip of the siding member of the upper siding panel, and the top end of the backing member of the lower siding panel extends upwardly into the relief channel in the backing member of the upper siding panel.

20 **FIG. 9** is a side view of a composite siding panel according to the present disclosure showing exemplary dimensions for the siding member and the backing member.

25 **FIG. 10** is a rear view of one embodiment of a backing member according to the present disclosure. The rear face of the backing member can include

drainage grooves operable to remove water from an exterior wall to which the backing member is mounted.

FIG. 11 is side perspective view of a prior art composite siding panel. The prior art composite siding panel includes a siding member and a backing member.

5 **FIG. 12A** is a front perspective view of the prior art composite siding panel of **FIG. 11**. The backing member is attached to the siding member and is centrally located between the laterally-extending side edges of the siding member. Both side edges of the siding member extend beyond the side faces of the backing member. **FIG. 12B** is a rear perspective view of the prior art composite siding panel of **FIG. 11**. The backing member is centrally located between the laterally-extending side edges of the siding member, such that the siding member overhangs the backing member along both sides.

FIG. 13 is a front view of the prior art composite siding panel of **FIG. 11**. Solid lines indicate the perimeter of the siding member. The outer, lighter dashed lines indicate the perimeter of the portions of the backing member behind the siding member. The inner, darker dashed lines indicate where the placement of adhesive on the front face of the backing member starts and stops. The siding member includes vinyl cutouts along both edges of the siding member proximate a top end thereof.

20 **FIG. 14** is another front view of the prior art composite siding panel of **FIG. 11**, showing additional details. Again, solid lines indicate the perimeter of the siding member, and the outer dashed lines indicate the perimeter of the portions of the backing member behind the siding member. The shaded area and inner dashed lines indicate where the placement of adhesive on the front face of the backing member starts and stops. The siding member includes an overhang along both sides of the siding member.

FIG. 15 is a front view of a prior art siding assembly comprising two of the composite siding panels of **FIG. 11** placed side-to-side adjacent one another with the backing members abutting one another (i.e., foam on foam contact). Again, solid lines indicate the perimeters of the siding members, and the outer dashed lines indicate the perimeter of the portions of the backing members behind the

siding members. The lighter shaded area and inner dashed lines indicate where the placement of adhesive on the front faces of the backing members starts and stops. The darker shaded area indicates the location of an adhesive gap (where no adhesive is present) between the backing members of the two adjacent siding panels.

FIGS. 16A-16E are a set of pictures showing an experiment using an acrylic adhesive in the overhanging section between two siding panels. In **FIG. 16A**, the acrylic adhesive is visible as a double-sided tape with a release liner still applied. In **FIG. 16B**, the release liner is being peeled off. In **FIG. 16C**, the acrylic adhesive / tape is visible. In **FIG. 16D**, the second siding panel is being applied upon the acrylic adhesive / tape. In **FIG. 16E**, the two siding panels are joined together. The acrylic adhesive / tape is not visible.

FIGS. 17A-17C are a set of pictures showing an experiment using an acrylic adhesive to join wood to foam. **FIG. 17A** shows the piece of wood on the left, and the foam with an acrylic adhesive strip in the form of a double-sided tape with a release liner still applied. **FIG. 17B** shows the release liner fully removed from the acrylic adhesive strip. **FIG. 17C** shows the wood adhered to the foam via the acrylic adhesive.

FIGS. 18A-18D are a set of pictures showing an experiment using an acrylic adhesive to join fiber cement to foam. **FIG. 18A** shows the fiber cement on the right and the foam on the left with two strips of acrylic adhesive in the form of a double-sided tape with a release liner still applied. **FIG. 18B** shows the release liner fully removed from one strip and in the process of being removed from the second strip. **FIG. 18C** shows the two strips of acrylic adhesive. **FIG. 18D** shows the fiber cement adhered to the foam via the acrylic adhesive.

DETAILED DESCRIPTION

A more complete understanding of the components, panels, assemblies, and processes disclosed herein can be obtained by reference to the accompanying drawings. These figures are merely schematic representations based on convenience and the ease of demonstrating the present disclosure, and

are, therefore, not intended to indicate relative size and dimensions of the devices or components thereof and/or to define or limit the scope of the exemplary embodiments. In the drawings and the following description below, it is to be understood that like numeric designations refer to components of like function.

5 The present disclosure may be understood more readily by reference to the following detailed description of desired embodiments and the examples included therein. In the following specification and the claims which follow, reference will be made to a number of terms which shall be defined to have the following meanings.

10 The singular forms "a," "an," and "the" include plural referents unless the context clearly dictates otherwise.

 The term "comprising" is used herein as requiring the presence of the named components/steps and allowing the presence of other components/steps. The term "comprising" should be construed to include the term "consisting of",
15 which allows the presence of only the named components/steps, along with any impurities that might result from the manufacture of the named components/steps.

 Numerical values should be understood to include numerical values which are the same when reduced to the same number of significant figures and numerical values which differ from the stated value by less than the experimental
20 error of conventional measurement technique of the type described in the present application to determine the value.

 All ranges disclosed herein are inclusive of the recited endpoint and independently combinable (for example, the range of "from 2 grams to 10 grams" is inclusive of the endpoints, 2 grams and 10 grams, and all the intermediate
25 values).

 The terms "substantially" and "about" can be used to include any numerical value that can vary without changing the basic function of that value. When used with a range, "substantially" and "about" also disclose the range defined by the absolute values of the two endpoints, e.g. "about 2 to about 4" also discloses the
30 range "from 2 to 4." The terms "substantially" and "about" may refer to plus or minus 10% of the indicated number. It is noted that when the term "substantially"

is used in the context of describing the location of adhesive relative to edges of the backing member or the siding member, this term refers to +/- three-sixteenths of an inch (3/16 inch).

5 The present disclosure refers to components as having a length, width, height, and thickness. It is noted that “length” and “width” are used interchangeably herein, or put another way, these terms refer to the same dimension or axis.

10 It should be noted that many of the terms used herein are relative terms. For example, the terms “upper” and “lower” are relative to each other in location, i.e. an upper component is located at a higher elevation than a lower component in a given orientation, but these terms can change if the device is flipped. The terms “horizontal” and “vertical” are used to indicate direction relative to an absolute reference, i.e. ground level. The terms “above” and “below”, or “upwards” and “downwards” are also relative to an absolute reference; an
15 upwards flow is always against the gravity of the earth.

The term “parallel” should be construed in its lay term as two edges or faces generally continuously having the same distance between them, and should not be strictly construed in mathematical terms as requiring that the two edges or faces cannot intersect when extended for an infinite distance. Similarly, the term
20 “planar” should not be strictly construed as requiring that a given surface be perfectly flat.

FIGS. 11–14 show a prior art composite siding panel. **FIG. 15** shows a prior art siding assembly.

FIG. 11 generally shows the prior art siding system **305**, which includes a
25 backing member **310** and a siding member **320**. As can be seen in **FIG. 12A** and **FIG. 12B**, the backing member **310** is attached to the siding member **320**. As can be seen in **FIG. 14**, the backing member **310** includes adhesive **315** thereon, as indicated by shading. The adhesive **315** is centrally located on the backing member **310** between the laterally-extending side faces **316, 318** thereof, and is
30 spaced apart from those side faces.

FIG. 13 is a front view that shows the placement of the backing member **310** relative to the siding member **320** and the relative placement of the adhesive **315** on the backing member **310**. As can be seen in **FIG. 13**, the siding member **320** has a first side edge **326** and a second side edge **328** at the opposite side thereof. A nailing hem **330** is present at the top of the siding member **320**. However, the length **331** of the nailing hem **330** along the top of the siding member is shorter than the length **333** of the bottom edge **332** of the siding member, with the nailing hem being centered along the top of the siding member **320**. Put another way, the siding member **320** has cutouts **321**, **323** along both the first and second side edges **326**, **328** thereof. The cutouts are defined by how far the first and second side edges **326**, **328** of the siding member **20** extend beyond the nailing hem. In this embodiment, each cutout has a length of 1.50 inches.

Continuing, the backing member **310** is located behind the siding member **320**, and has a rectangular shape. The first side face **316** of the backing member **310** is spaced apart or away from the first side edge **326** of the siding member **320**. The second side face **318** of the backing member **310** is also spaced apart or away from the second side edge **328** of the siding member **320**. Put another way, the side faces of the backing member are not aligned with the side edges of the siding member. Rather, the backing member **310** runs from a point short of the first side edge **326** of the siding member **320** to a point short of the second side edge **328** of the siding member **320**. This results in a small "overhang" on each side, where the side edge of the siding member extends beyond the backing member. The overhangs are better seen in **FIG. 14**, and are numbered with reference numerals **341**, with each overhang having a length of 0.375 inches to 1.25 inches, with the most common overhang value being 0.75 inches.

With reference again to **FIG. 14**, the portion of the backing member **310** that is covered with adhesive **315** is indicated by shading thereon. As can be seen in **FIG. 14**, the adhesive **315** does not run completely to either of the laterally-extending front side edges of the backing member **310**. Instead, the adhesive **315** is set back from both the first front side edge **316** of the backing

member **310** and the second front side edge **318** of the backing member **310**. This creates an adhesive setback **343** from the first and second side edges of the siding member, which here is 3.25 inches along both the first and second side edges **326, 328** of the siding member **320** (length indicated with reference numeral **343**). There is no adhesive present in this setback, and it can be seen that there is no adhesive along the first 1.5 inches to 3.5 inches of each side of the front face of the backing member (length indicated with reference numeral **345**), with the most common setback being 2.5 inches.

FIG. 15 illustrates a siding assembly **307** comprising two prior art composite siding panels **305, 306**. The composite siding panels **305, 306** are placed side-by-side adjacent one another with the backing members abutting one another (i.e., foam on foam contact). As previously mentioned, there is commonly a 2.50 inch setback on each side of the rear face of the backing member. Thus, there is commonly a 5.00 inch adhesive gap (i.e., a zone in which no adhesive is present) between the backing members of the adjacent siding panels, although this adhesive gap can vary from 3.0 inches to 7.0 inches. The siding panel overhangs overlap each other in the zone with reference numeral **308**. It is noted that because the prior art panels are symmetrical with the backing members of each siding panel centrally located on the siding members thereof, such that each siding panel has two overhangs and two adhesive setbacks, an adhesive gap will be present between two siding panels placed side-to-side, regardless of which siding panel overlaps the other.

The presence of adhesive gaps in prior art siding systems and assemblies leads to certain problems. The presence of such adhesive gaps does not allow the backing members to be seamlessly attached to the siding members. Furthermore, the siding members can be subject to undesirable buckling and stretching in the area of the adhesive gap, which results in an unacceptable, uneven, unsightly exterior surface. Disclosed herein are composite siding panels and assemblies that address the concerns of the aforementioned shortcomings or limitations of prior art siding systems and assemblies.

FIG. 1 shows an improved composite siding panel **101** according to the present disclosure, which includes a backing member **100** and a siding member **200**. As can be seen in **FIG. 2A** and **FIG. 2B**, the siding member **200** is in overlying relationship with and attached to the backing member **100**. As can be further seen in **FIG. 2A**, the bottom face **213** of the siding member **200** can include several drainage holes **236** for expelling water or moisture that may be present behind the siding member **200** once the composite siding panel **101** is installed. It is noted that composite siding panels are typically several feet in length, and that they are depicted in these figures as being shorter for illustrative purposes only (so that both sides can be seen).

FIG. 3A illustrates certain features of an exemplary siding member **200** according to one embodiment of the present disclosure. The siding member **200** has a front face **202** and a rear face **204**, which are located opposite each other. As better seen in **FIG. 4** and **FIG. 5**, the siding member **200** also includes longitudinally-extending first and second side edges **206**, **208**. In **FIG. 4**, the first side edge **206** of the siding member **200** is located along the left side thereof and the second side edge **208** of the siding member **200** is located along the right side thereof. The first and second side edges **206**, **208** of the siding member **200** generally extend parallel to one another.

With reference back to **FIG. 3A**, the siding member **200** of this exemplary embodiment includes a locking flange **220** proximate a top end **210** of the siding member **200**. The siding member **200** of this exemplary embodiment further includes a locking lip **222** proximate a bottom end **212** of the siding member **200**. The locking flange **220** is complementary in shape to the locking lip **222**. In this way, the locking flange **220** can operably engage or cooperate with the locking lip **222** of another siding member stacked above it.

The siding member **200** can be any desired shape or size, as will be appreciated by those skilled in the art, and usually have a length of several feet. In this regard, the siding member **200** can have any suitable configuration, profile, or contour suitable for a given application. The siding member **200** can be formed from any suitable material, namely a material suitable as an aesthetic outer

surface of a building or the like. In particular embodiments, the siding member **200** can be formed of vinyl, polypropylene, aluminum, steel, fiberglass, engineered wood, or fiber cement. It is contemplated that the siding member **200** could have some other polymeric veneer profile. It is contemplated that the siding member **200** will be composed of a suitable polymeric material, with vinyl materials being particularly suitable. The siding member **200** can have any suitable thickness, which is usually less than 0.1 inches. Usually, the structural strength of the backing member **100** is such that the need for structural strength and integrity of the siding member **200** is minimized. It is contemplated that the siding member **200** can be composed of any suitable sheet or film stock material. Materials of choice typically will be materials resistant to extremes in the external environment over the life of the siding system. Non-limiting examples of environmental challenges include extremes in temperature, prolonged exposure to ultraviolet light, and/or certain levels of impact and vibrational challenges due to wind and the like. In this regard, it is contemplated that the siding member **200** will be composed of any suitable polymeric, metal, plastic (e.g., fiber-reinforced plastic), composite wood, or cementitious material capable of providing suitable environmental resistance and durability.

FIG. 3B illustrates certain features of an exemplary backing member **100** according to the present disclosure. The backing member **100** has a front face **102** and a rear face **104**, located opposite each other. The rear face **104** is planar, such that it is mountable on another planar surface, such as an exterior wall of a building. With reference to **FIG. 5**, the backing member **100** includes longitudinally-extending first and second side faces **106, 108**. Front side edges **107, 109** (see **FIG. 2A** and **FIG. 2B**) are present at the intersection of the front face **102** with each side face **106, 108**. For example, first front side edge **107** is present at the intersection of the front face **102** with the first side face **106**, and second side edge **109** is present at the intersection of the front face **102** with the second side face **108**. In **FIG. 5**, the first side face **106** of the backing member **100** is located along the left side thereof and the second side face **108** of the backing member **100** is located along the right side thereof. The first and second

side faces **106, 108** of the backing member **100** are generally planar and extend parallel to one another.

With reference back to **FIG. 3B**, the backing member **200** of this exemplary embodiment includes a laterally-extending relief channel **122** defined in the rear face **104** and located proximate a bottom end **112** of the backing member **100**.
5 The relief channel **122** generally runs from the first side face **106** to the second side face **108** of the backing member **100** (i.e., from a first rear side edge **103** to a second rear side edge **105** of the backing member, as seen in **FIG. 2B**) and is configured to be complementary to the top end **110** of a longitudinally adjacent
10 backing member located below it, or in other words so the top end fits in the relief channel **122** (see **FIG. 8B**). In this embodiment, they are shaped in the form of a tongue **110** and a groove **122**, which are used to join adjacent panels together vertically. The backing member **100** also has a contour **140** defined therein. As can be seen with reference to **FIG. 3A**, the siding member **200** has one or more
15 complementary-shaped contours **240** defined therein. In this way, the siding member **200** can be configured to be in overlying relationship with the backing member **100** and be closely attached thereto without any gap present therebetween. It is contemplated that the backing member **100** and the siding member **200** may have any suitable configuration desired or required to impart
20 the aesthetic look desired. Put another way, the front face **102** of the backing member **100** can be angled with respect to the rear face **104** of the backing member **100**.

The backing member **100** can be molded to any desired shape or size, as will be appreciated by those skilled in the art, and usually have a length of several
25 feet. In particular embodiments, the backing member **100** can be composed of closed-cell expanded foam, such as a polymeric foam like expanded polystyrene (EPS) foam. In other embodiments, the backing member **100** can be formed from wire-fabricated foam.

Turning now to **FIG. 4**, another perspective view of the composite siding panel **101** is provided. As can be seen here, composite siding panel **101** is formed
30

by configuring the rear face **204** of the siding member **200** to be in overlying relationship with and attached to the front face **102** of the backing member **100**.

The siding member **200** can be attached to the backing member **100** in a wide variety of fashions. It is contemplated that connection can occur at any time
5 between manufacture and installation such that the siding member **200** and backing member **100** are joined to one another in the installed or "in use" configuration. In the present disclosure, an adhesive is used to join the siding member **200** and backing member **100**, though other non-limiting examples of attachment include procedures such as the use of mechanical fasteners and/or
10 chemical bonding at any location either prior to or during installation. The methods can be mixed as desired or required.

Where adhesive materials are to be employed, the adhesive can be applied by any suitable method. An adhesive coating can be located between the siding member and the backing member. Put another way, an adhesive
15 coating joins the rear face of the siding member to the front face of the backing member. The coating can be continuous or discontinuous. The adhesive material can be applied as one or more beads, ribbons, dots, or swirls. The adhesive can also be applied in a thin layer or the like. It is particularly contemplated that the adhesive material can be applied so as to substantially cover the rear face **204** of
20 the siding member **200** or the front face **102** of the backing member **100** in the horizontal direction (e.g., to run substantially from the first side face **106** / the first front side edge **107** to the second side face **108** / the second front side edge **109** of the backing member **100**). Again, it is noted that the margin of error for applying adhesive to these edges is $\pm 3/16$ inch. In certain applications, it is contemplated
25 that the adhesive can be applied by a suitable spray applicator to provide a thin uniform adhesive coating over the tough durable skin of the backing member. The backing member **100** may have a smooth surface finish that fits snugly with the siding member **200**, thereby increasing adhesive mileage and reducing adhesive quantities, with the resulting bond being stronger. In this way, it may
30 not be necessary to completely cover the backing member **100** with adhesive in order to suitably join the backing member **100** and the siding member **200**.

Suitable materials for the adhesive include continuously flexible non-latex adhesives, such as thermoplastic PSAs, UV curable adhesives and hot melt adhesives, such as polyamines and urethanes, glue, thermosetting or thermoplastic adhesives, or pressure sensitive adhesives. Non-limiting examples
5 of suitable spray thermoplastic adhesive coating materials include those commercially available from National Starch under the trade name DUROTAK, or available from Henckel under the trade name PURHM QR9011.

Because they are to be attached to each other, the rear face **204** of the siding member **200** is generally shaped complementary to the front face **102** of
10 the backing member **100**, as previously explained. It is contemplated that the backing member **100** can be shaped to have a suitable configuration complementary to the configuration of the siding member **200**. Suitable configurations are depicted in the various drawings, though other suitable configurations are possible, as will be appreciated by those skilled in the art. The
15 degree of correspondence between the shape of the siding member **200** and the shape of the backing member **100**, including any contours defined in either, can be at any degree from approximate to exact depending on various factors, including but not limited to the material type and/or thickness of the siding member
200.

20 As can be seen in **FIG. 4** and **FIG. 5**, the second side face **108** of the backing member **100** is positioned contiguously with (i.e. lined up with or sharing an edge with) the second side edge **208** of the siding member **200**. Put another way, the second side face **108** of the backing member **100** is aligned with the second side edge **208** of the siding member **200** when viewed from the front. The
25 second front side edge **109** of the backing member **100** is therefore also positioned contiguously or aligned with the second side edge **208** of the siding member **200**. In contrast, the first side face **106** and the first front side edge **107** of the backing member **100** are not positioned contiguously with or aligned with the first side edge **206** of the siding member **200**. Rather, the first side edge **206**
30 of the siding member **200** extends outwardly beyond the first side face **106** and the first front side edge **107** of the backing member **100**, thereby creating an

overhang **260**, as indicated by the dashed line in **FIG. 4**. In other words, the overhang **260** runs from the first side edge **206** of the siding member **200** to the first side face **106** / first front side edge **107** of the backing member **100**, such that the width of the overhang **260** is defined by the distance between the first side edge **206** of the siding member **200** and the first side face **106** / first front side edge **107** of the backing member **100**. The rear surface of the overhang, or the rear surface of the siding member that makes up the overhang, is indicated with reference numeral **262** in **FIG. 4**. The width of the overhang is indicated as reference numeral **261** in **FIG. 5**. Also visible in **FIG. 5** is dotted rectangle **265**, which represents an adhesive layer that can optionally be placed on the rear surface of the overhang, as will be discussed further herein.

As can be further seen in **FIG. 4**, the siding member **200** includes a nailing hem **230** proximate a top end **210** of the siding member **200**. The nailing hem **230** has a plurality of apertures **232** therein for securing the composite siding panel **101** to a surface, such as an exterior wall of a building. The nailing hem **230** generally runs from the first side edge **206** of the siding member **200** to short of the second side edge **208** thereof. Similarly, the locking flange **220** of the siding member **200** generally runs from the first side edge **206** of the siding member **200** to short of the second side edge **208** thereof. This results in a cutout **243** located on the second side edge **208** of the siding member, but no cutout on the first side edge **206** of the siding member.

As explained above, the locking flange **220** and the nailing hem **230** generally run from the first side edge **206** of the siding member **200** to a point short of the second side edge **208** thereof, as shown in **FIG. 5**. This creates a cutout **243** along the second side edge **208** of the siding member **200**. In particular embodiments, the cutout has a length **245** of about 2.00 inches (i.e., the distance from the second side edge **208** of the siding member **200** to the locking flange **220** and the nailing hem **230**). As can be seen in **FIG. 5**, a top end **110** of the backing member **100** extends upwardly beyond a top end **210** of the siding member **200**, and a portion of the backing member **100** is present behind the cutout **243** in the siding member **200**. Thus, in some embodiments, the

adhesive coating can also be described as running substantially vertically from a bottom front edge **117** of the backing member to a top edge **215** of the siding member. Adhesive may also be present behind the nailing hem **230** if desired. In embodiments where the top edge of the siding member extends upwardly beyond the top edge of the backing member, the adhesive layer can be described as running substantially vertically from a bottom edge of the backing member to a top edge of the backing member.

Turning now to **FIG. 6**, the adhesive coating **150** is illustrated upon the front face **102** of the backing member **100**. In **FIG. 6**, the shaded portion indicates the area within which the adhesive coating **150** can be placed (i.e., where application of the adhesive generally starts and stops), and is not intended to indicate that the adhesive always covers the entire front face **102** of the backing member **100**. The margin of error for applying adhesive to these edges is $\pm 3/16$ inch. The adhesive can be applied discontinuously in the form of one or more beads, ribbons, dots, or swirls that run substantially from the first side face **106** / first front side edge **107** to the second side face **108** / second front side edge **109** of the backing member **100**. The adhesive coating can also be continuous. In particular embodiments, the adhesive is continuous and covers substantially the entire front face **102** of the backing member from the top end **110** of the backing member **100** to the bottom end **112** thereof, and from the first front side edge **107** of the first side face **106** of the backing member to the second front side edge **109** of the second side face **108** of the backing member. In other words, the adhesive can be applied such that there is no adhesive setback from the second front side edge **109** of the backing member **100** on the composite siding panel **101** (again keeping in mind the $\pm 3/16$ inch margin of error). In other embodiments, the adhesive coating **150** extends from the bottom front edge **117** of the backing member **100** to the top edge **215** of the siding member **200**, and from the first front side edge **107** of the first side face **106** of the backing member to the second front side edge **109** of the second side face **108** of the backing member.

It is contemplated that the adhesive on the front face **102** of the backing member **100** may be continuous over the entire surface of the front face **102** of

the backing member **100** or may be discontinuous, i.e. in discrete locations instead, as explained above. The shaded area of **FIG. 6** indicates the maximum size of the adhesive coating **150** (i.e., the areas within which the adhesive can be placed with a $\pm 3/16$ inch margin of error).

5 Deposition of the adhesive coating **150** can be by any suitable method with methods that reduce or eliminate telegraphing through the overlying siding member being preferred. Thus, spray deposition can be utilized as well as methods such as extrusion, roller coating, curtain coating, and the like.

10 In particular embodiments, such as that shown in **FIG. 6**, the siding member overhangs the backing member by at least $3/8$ inch (0.375 inches) and up to a maximum of about 1.25 inches (indicated by length **261**), with most panels having a 0.75 inch overhang. Again, no overhang is present along the second side edge **208** of the siding member **200** because the second side face **108** / second front side edge **109** of the backing member **100** is positioned contiguously
15 with or is aligned with the second side face **208** of the siding member **200**. In particular embodiments, the overhang **260** has a length **261** that is less than the length **245** of the cutout **243**. The difference in their lengths can be from about 0.25 inches to about 1.0 inches.

20 **FIG. 7** illustrates an improved siding assembly **470** according to the present disclosure. The assembly **470** comprises two composite siding panels **450, 460**. Please note that these composite siding panels differ from those in **FIG. 6** in that the first side and the second side are now reversed. The composite siding panels **450, 460** are placed laterally adjacent one another (i.e. side-to-side) with the backing members abutting one another (i.e., foam-on-foam contact).
25 Because the front faces of the backing members **100, 100a** are covered with adhesive running substantially from the first side face / first front side edge to the second side face / second front side edge of the backing members, installation of the siding systems **450, 460** side-by-side results in no adhesive gap being present between the backing members (or at most $6/16$ inch, considering the margin of
30 error). Thus, the undesirable adhesive gap present in prior art siding systems and assemblies is eliminated.

As seen here, composite siding panel **450** has a backing member **100** with first side face **106** and second side face **108** and first front side edge **107** and second front side edge **109**, and also has a siding member **200** with first side edge **206** and second side edge **208**. Composite siding panel **460** has a backing member **100a** with first side face **106a** and second side face **108a** and first front side edge **107a** and second front side edge **109a**, and also has a siding member **200a** with first side edge **206a** and second side edge **208a**. The first side face **106** of backing member **100** abuts second side face **108a** of backing member **100a**. The first side edge **206** of siding member **200** lies over the siding member **200a**, while the second side edge **208a** of siding member **200a** is aligned with the second side face **108a** and the second front side edge **109a** of the backing member **100a**.

Due to the cutout **243a** along the second side edge **208a** of the siding member **200a** of the composite panel **460** being longer than the overhang **260** of composite panel **450**, there is a gap **234** between the nailing hems and locking flanges of adjacent siding panels, as shown in **FIG. 7**. In particular, due to the 2.00 inch cutout and the 1.25 inch overhang, installation of the siding systems **450, 460** of this exemplary embodiment results in a 0.75 inch gap between the nailing hems and locking flanges of the adjacent composite siding panels **450, 460**. Such a gap **234** permits vinyl siding members, which have high coefficients of expansion and contraction, especially when exposed to heat, such as from sun exposure, to expand without undesirably interfering with the adjacent siding member. This, coupled with the use of an adhesive to join backing members and siding members as described herein, prevents or eliminates the undesirable buckling and stretching encountered with prior art siding systems and assemblies.

FIG. 8A and **FIG. 8B** illustrate one exemplary embodiment of how two identical and longitudinally adjacent siding panels **450, 460** can be installed one above the other. In **FIG. 8A**, siding panel **450** is to be installed above siding panel **460**, as indicated by the arrow showing in what direction the panels are joined.

The lower siding panel **460** includes a locking flange **220** and the upper siding panel **450** includes a locking lip **222**. The locking flange **220** of the lower

siding panel **460** is complementary in shape to the locking lip **222** of the upper siding panel **450**. In this way, the locking flange **220** of the lower siding panel **460** is configured to operably engage with the locking lip **222** of the upper siding panel **450**. **FIG. 8B** shows laterally adjacent siding panels **450, 460** operably engaged with one another via the locking flange **220** of siding panel **460** and the locking flange **222** of siding panel **450**.

The upper siding panel **450** includes a laterally-extending relief channel **122**. The relief channel **122** is configured to be complementary to top end **110** of the lower siding panel **460**. **FIG. 8B** shows laterally adjacent siding panels **450, 460** with the relief channel of the upper siding panel **450** engaging the top end of the lower siding panel **460**. As shown in **FIG. 8B**, the top end of the lower siding panel **460** extends at least partially into the relief channel of the upper siding panel **450**. The top end does not need to entirely fill the relief channel.

FIG. 9 illustrates an exemplary embodiment of a siding panel **450** according to the present disclosure, with exemplary dimensions (all of which are in inches in this figure). In this exemplary embodiment, the relief channel in the rear face of the backing member **100** has a height of about 1.13 inches and a depth of about 0.50 inches. The siding member **200** has a total length of about 17 inches. The length of the portion of the siding member **200** below the contour **240** therein is about 7.00 inches, and the length of the portion of the siding member **200** above the contour **240** therein is about 10.00 inches. The contour **240** in the siding member **200** and the contour **140** in the backing member **100** each have a depth of about 1.13 inches. The backing member **100** has a thickness of about 0.50 inches along its top end. The backing member **100** has a total length of about 14.02 inches. It is noted that in this embodiment, the top edge of the siding member extends beyond the top edge of the backing member. Thus, the adhesive coating could extend vertically substantially from the bottom edge of the backing member to the top edge of the backing member, if desired.

The composite siding panels and siding assemblies disclosed herein may include additional features, as will be appreciated by those skilled in the art. For example, the opposing first and second side edges of the backing member can

include an interlocking tab and slot arrangement. Examples of such an interlocking tab and slot arrangement can be found in commonly-owned U.S. Patent No. 8,910,444.

As another example, the backing member **100** can include drainage grooves **130** in the rear face **104** thereof, as seen in **FIG. 10**. As seen in **FIG. 10**, the drainage grooves **130** extend into the rear face **104** of the backing member **100**, such that projections or protrusions **132** are defined between the drainage grooves **130**. In this way, upon mounting the backing member **100** to a surface, such as the exterior wall of a building, the projections **132** are seated directly against the surface of the exterior wall, while the drainage grooves **130** do not contact the surface of the exterior wall. As such, the drainage grooves **130** are operable to remove water or other moisture from the surface of the exterior wall so as to prevent molding. It is further noted that, as seen in **FIG. 10**, the drainage grooves **130** are designed to extend continuously from the top end **110** of the backing member **100** to the bottom end **112** thereof. Because they are oriented diagonally, the drainage grooves also run from the first rear side edge **107** of the backing member **100** to the second rear side edge **109** thereof, and vice versa.

As an additional example, as previously described with respect to **FIG. 4** and **FIG. 5**, an adhesive layer **265** can be present on the rear surface of the overhang. In this regard, warping can occur in vinyl siding, which results in an undesirable appearance, particularly at the interface between vinyl siding panels. This is due to the expansion and contraction of the vinyl. The adhesive layer **265** should be made from adhesives such as an acrylic adhesive, which can withstand large temperature differences from -20°F to $+180^{\circ}\text{F}$ while remaining flexible. In contrast, liquid-based adhesives, such as epoxy adhesives, have been found to be unable to withstand such temperature differences, breaking down so that vinyl siding panels do not remain adhered to each other.

In practice, the acrylic adhesive is usually provided in the form of a double-sided coated tape with release liners. The tape can be applied to join the overhang of one siding member of a first composite siding panel to the siding

member of an adjacent second composite siding panel. An example of an acrylic adhesive that has been found to work is 3M VHB tape, which is a tape with a foam core and adhesive applied on both sides thereof. Specific examples include 3M VHB RP25, VHB RP32, and VHB 4936 tapes. The adhesive may have a 90° peel
5 adhesion strength of about 30 N/cm. Other examples include 3M JVCC DC-SCRIM-3 tape and 3M F9465PC tape, which are also based on acrylic adhesives. It should be noted that the double-sided coated tape should use a foam core and adhesive on both surfaces thereof. It has been found that double-sided tapes which have a polymeric sheet core (instead of a foam core) are not effective
10 during field usage because as the siding member expands and contracts during temperature changes, the adhesive smears on the siding member and separates from the polymeric sheet core. Such smearing and separation does not occur with foam cores. The double-sided tape may have a thickness of about 0.010 inch to about 0.05 inches. Generally, a thinner tape is preferred because it is
15 more visually pleasing when applied.

It is contemplated that various cellular plastics can be employed as the material for the backing members disclosed herein. As used herein, the term(s) "cellular foam" or "cellular foam plastic" are taken to mean a plastic or polymeric material with numerous cells of trapped air distributed throughout its mass.
20 Suitable examples of such materials can also be referred to as expanded plastics or foamed plastics with expanded polystyrene foam being but one non-limiting example.

"Expanded polystyrene foam" as used herein refers to cellular foam plastic made from polystyrene typically by incorporation of a volatile blowing agent into polystyrene beads as they are polymerized or afterward. In expanded
25 polystyrene, beads of polystyrene are first pre-expanded and allowed to rest for a suitable interval, then molded in closed steam-heated shaped molds to produce closed-cell molded foams. The size and density of the closed cells can vary from application to application.

30 The backing members of the present disclosure can have a tough, durable, smooth skin on the outer surface of the front and rear faces as well as any ends,

edges, and additional surfaces. It is contemplated that the siding member may be traditional vinyl veneer material at thickness measuring from about 0.020 to about 0.036 inches. Various other polymeric or coating materials as would be cost effective can be used.

5 The backing member can also have various three-dimensional features located on one or more of the front face, rear face, top end, bottom end, or side edges as would be suitable for the associated composite siding panel. The three-dimensional features can include but are not limited to ridges, grooves, indents, detents and the like. Such geometric features can be imparted in a single
10 operation by the shape molding process.

The backing member can also be pigmented as desired or required. In situations where the siding member is extremely thin, it is contemplated that the backing member can be pigmented to complement the color of the extremely thin siding member.

15 The following examples are presented to illustrate the composite panels described herein, and are not intended to limit the present disclosure.

EXAMPLES

EXAMPLE 1

20 Acrylic adhesive (in the form of a tape) was applied to the overhang / interface of two vinyl siding members. In **FIG. 16A**, the acrylic adhesive is visible as a double-sided tape with a release liner still applied. In **FIG. 16B**, the release liner is being peeled off. In **FIG. 16C**, the acrylic adhesive / tape is visible. In **FIG. 16D**, the second siding panel is being applied upon the acrylic adhesive /
25 tape. In **FIG. 16E**, the two siding panels are joined together to form a seam. The acrylic adhesive / tape is not visible.

Heat was then applied to the seam, and the failure temperature was measured. Failure was indicated by warping. These were compared to (A) a normal seam with no adhesive and (B) a seam that used glue. The results are
30 seen in the following table. Briefly, the use of acrylic adhesive (tape) worked better than no adhesive or the glue.

Seam lap	Failure temperature (°F)	Notes
Normal	183	Seam puckered inward
Normal	183	Seam puckered inward
Normal	185	Seam puckered inward
Taped	199	Seam had very little inward pucker
Taped	200	Seam had very little inward pucker
Taped	204	Seam had very little inward pucker
Glued	203	Seam was not as noticeable as other tests
Glued	201	
Glued	198	

5 **FIGS. 17A-17C** are a set of pictures showing an experiment using an acrylic adhesive to join wood to foam. **FIG. 17A** shows the piece of wood on the left, and the foam with an acrylic adhesive strip in the form of a double-sided tape with a release liner still applied. **FIG. 17B** shows the release liner fully removed from the acrylic adhesive strip. **FIG. 17C** shows the wood adhered to the foam via the acrylic adhesive.

10 **FIGS. 18A-18D** are a set of pictures showing an experiment using an acrylic adhesive to join fiber cement to foam. **FIG. 18A** shows the fiber cement on the right and the foam on the left with two strips of acrylic adhesive in the form of a double-sided tape with a release liner still applied. **FIG. 18B** shows the release liner fully removed from one strip and in the process of being removed from the second strip. **FIG. 18C** shows the two strips of acrylic adhesive. **FIG. 15 18D** shows the fiber cement adhered to the foam via the acrylic adhesive.

EXAMPLE 2

20 Environmental chamber tests were conducted according to ASTM D3679 to compare the expansion of (A) a naked vinyl siding panel against (B) a composite siding panel having a foam backing member attached to a vinyl siding member, with adhesive running substantially between the side edges and the top / bottom edges.

The environment chamber tests were conducted by reducing the temperature to -20°F over two hours, then holding at -20°F for two hours. The temperature was then increased to +160°F over two hours, then held at +160°F for 2 hours. The change in length of the siding panel was measured between
5 these two temperatures.

The naked vinyl siding panel expanded one-half inch (1/2 inch) over a 16-foot length. In contrast, the composite siding panel only expanded one-half inch (1/2 inch) over a 30-foot length. This is a roughly 50% reduction in expansion (a lower degree of expansion is preferable).

10 Tests were also performed with two composite siding panels (B). When adhesive was applied to the overhanging portion of the vinyl siding members (to bond the overlap), the degree of expansion was not changed. The panels still only expanded one-half inch over a 30-foot length.

The present disclosure has been described with reference to exemplary
15 embodiments. Obviously, modifications and alterations will occur to others upon reading and understanding the preceding detailed description. It is intended that the present disclosure be construed as including all such modifications and alterations insofar as they come within the scope of the appended claims or the equivalents thereof.

20

**THE EMBODIMENTS OF THE INVENTION IN WHICH AN EXCLUSIVE
PROPERTY OR PRIVILEGE IS CLAIMS ARE DEFINED AS FOLLOWS:**

1. A composite siding panel, comprising:
 - a backing member having a front face, a rear face opposite the front
5 face thereof, and longitudinally extending first and second side edges;
 - a siding member having a front face, a rear face opposite the front
face thereof, and longitudinally-extending first and second side edges, and a
cutout on the second side edge proximate a top end of the siding member; and
 - an adhesive coating that joins the rear face of the siding member to
10 the front face of the backing member, wherein the adhesive coating runs
substantially from the first side edge of the backing member to the second side
edge of the backing member; and
 - wherein the first side edge of the siding member extends outwardly
beyond the first side edge of the backing member to create an overhang, and the
15 second side edge of the siding member is aligned with the second side edge of
the backing member.

2. The composite siding panel of claim 1, wherein the adhesive coating
also extends substantially from a bottom front edge of the backing member to a
20 top edge of the siding member.

3. The composite siding panel of claim 1, wherein the adhesive coating
is discontinuous and is in the form of one or more beads, ribbons, dots, or swirls.

- 25 4. The composite siding panel of claim 1, wherein the adhesive coating
extends substantially from the first side edge to the second side edge of the
backing member and from a top edge of the siding member to a bottom edge of
the backing member.

- 30 5. The composite siding panel of claim 1, wherein the siding member
overhangs the backing member by at least 0.375 inches.

6. The composite siding panel of claim 1, wherein the rear face of the backing member is substantially planar, and wherein the backing member further includes longitudinally-extending first and second side faces that are substantially planar and substantially parallel to each other.

7. The composite siding panel of claim 1, wherein the backing member is shape-molded and composed of closed-cell expanded foam, or wherein the backing member is formed from wire-fabricated foam.

8. The composite siding panel of claim 1, wherein the siding member is formed from vinyl, polypropylene, aluminum, steel, fiberglass, engineered wood, or fiber cement.

9. The composite siding panel of claim 1, wherein the backing member has one or more contours defined therein and the siding member has one or more complementary-shaped contours defined therein.

10. The composite siding panel of claim 1, wherein the siding member includes a nailing hem located proximate a top end thereof, the nailing hem having a plurality of apertures therein.

11. The composite siding panel of claim 10, wherein the nailing hem runs from the first side face of the siding member to short of the second side face.

12. The composite siding panel of claim 1, wherein a top end of the backing member extends upwardly beyond a top end of the siding member.

13. The composite siding panel of claim 1, wherein the backing member includes a laterally-extending relief channel defined in the rear face thereof and located proximate a bottom end thereof, the relief channel running from the first side edge to the second side edge of the backing member, and the relief channel
5 is shaped to fit a top end of the backing member.

14. The composite siding panel of claim 1, wherein the siding member includes a locking flange located proximate a top end thereof and a locking lip located proximate a bottom end thereof, wherein the locking flange is
10 complementary in shape to the locking lip.

15. The composite siding panel of claim 1, further comprising an adhesive layer on a rear surface of the overhang.

16. The composite siding panel of claim 15, wherein the adhesive layer
15 comprises an acrylic adhesive.

17. A composite siding panel, comprising:
a backing member having a front face, a rear face opposite the front
20 face thereof, and longitudinally-extending first and second side faces;
an adhesive coating located on the front face of the backing member and extending from the first side face to the second side face; and
a siding member having a front face, a rear face opposite the front
face thereof, and longitudinally-extending first and second side edges, and a
25 cutout on the second side edge proximate a top end of the siding member, the rear face of the siding member being attached to the front face of the backing member via the adhesive coating, the first side edge of the siding member extending outwardly beyond the first side face of the backing member to create
an overhang, and the second side edge of the siding member positioned
30 contiguously with the second side face of the backing member.

18. The composite siding panel of claim 17, wherein the adhesive coating on the front face of the backing member completely covers the front face of the backing member from the first side face to the second side face of the backing member and from a top face to a bottom face of the backing member.

5

19. The composite siding panel of claim 17, further comprising an adhesive layer on a rear surface of the overhang.

20. A siding system kit, comprising:

10

a composite siding panel that comprises:

a backing member having a front face, a rear face opposite the front face thereof, and longitudinally extending first and second side edges;

15

a siding member having a front face, a rear face opposite the front face thereof, and longitudinally-extending first and second side edges, and a cutout on the second side edge proximate a top edge of the siding member, the rear face of the siding member being attached to the front face of the backing member; and

20

an adhesive coating that joins the rear face of the siding member to the front face of the backing member, wherein the adhesive coating runs substantially from the first side edge of the backing member to the second side edge of the backing member;

25

wherein the first side edge of the siding member extends outwardly beyond the first side edge of the backing member to create an overhang, and the second side edge of the siding member is aligned with the second side edge of the backing member; and

a double-sided tape comprising:

30

a foam core with two opposing surfaces; and

an adhesive layer on each of the two opposing surfaces.

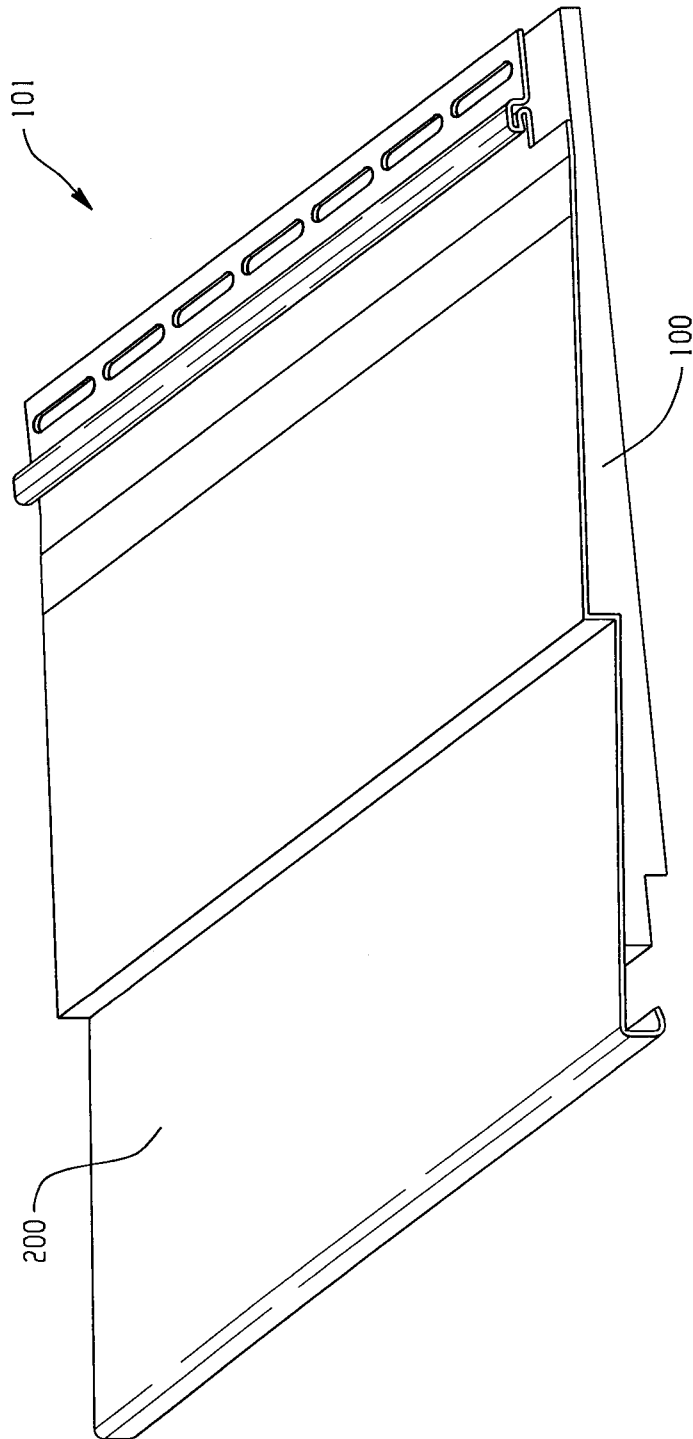

Fig. 1

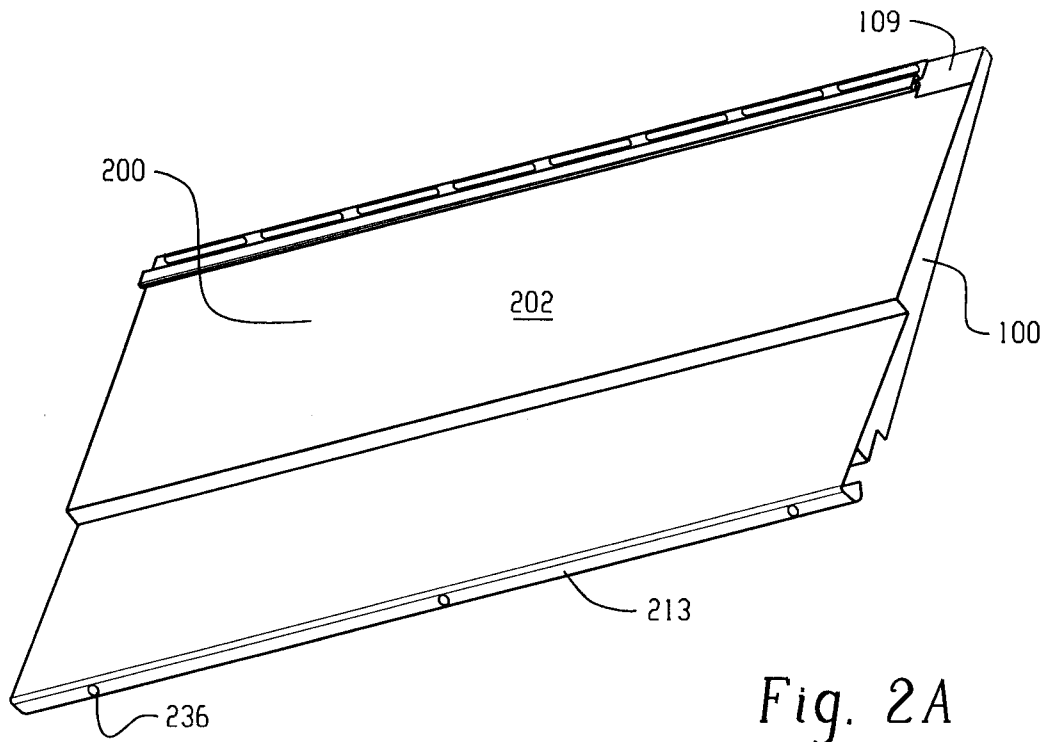

Fig. 2A

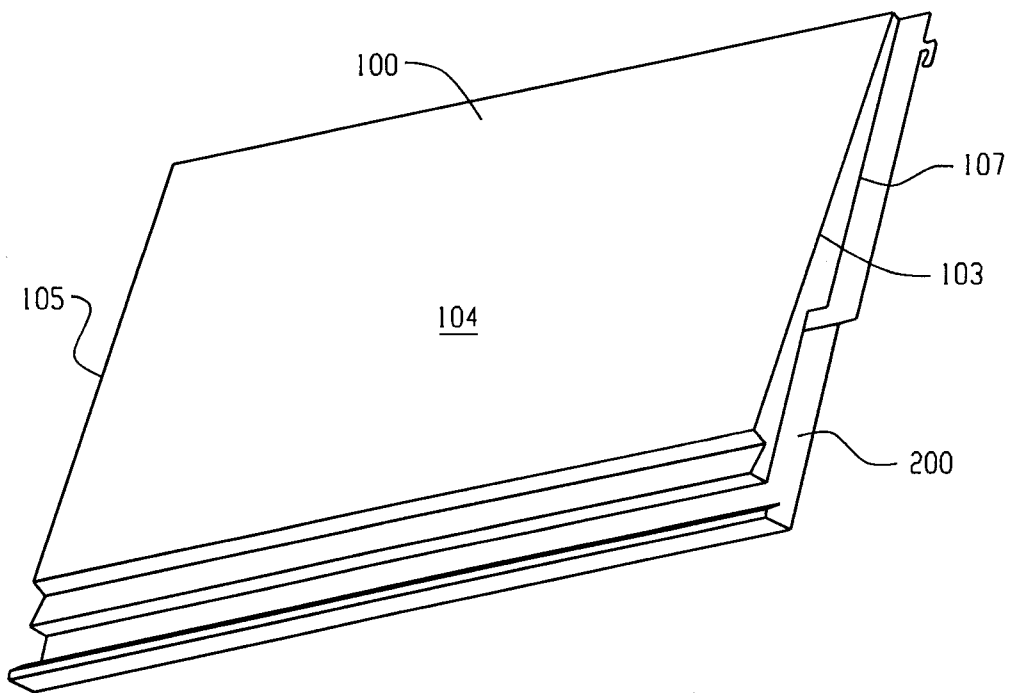

Fig. 2B

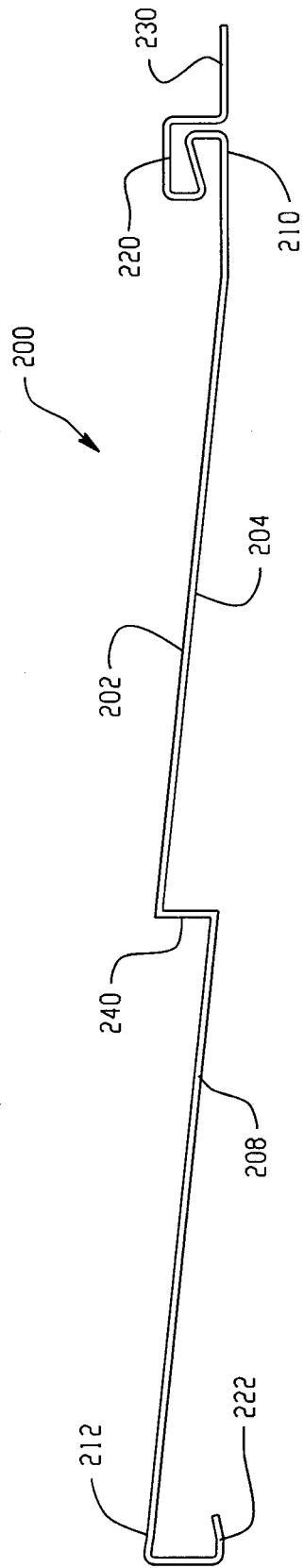

Fig. 3A

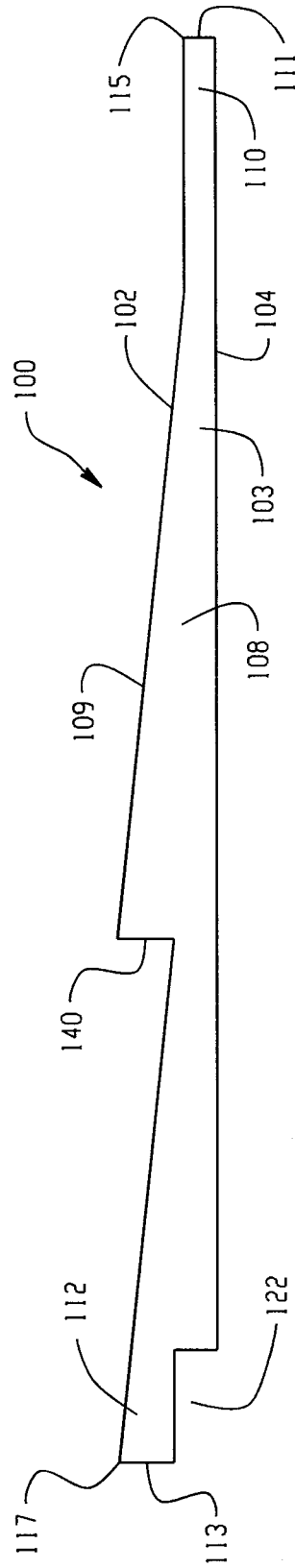

Fig. 3B

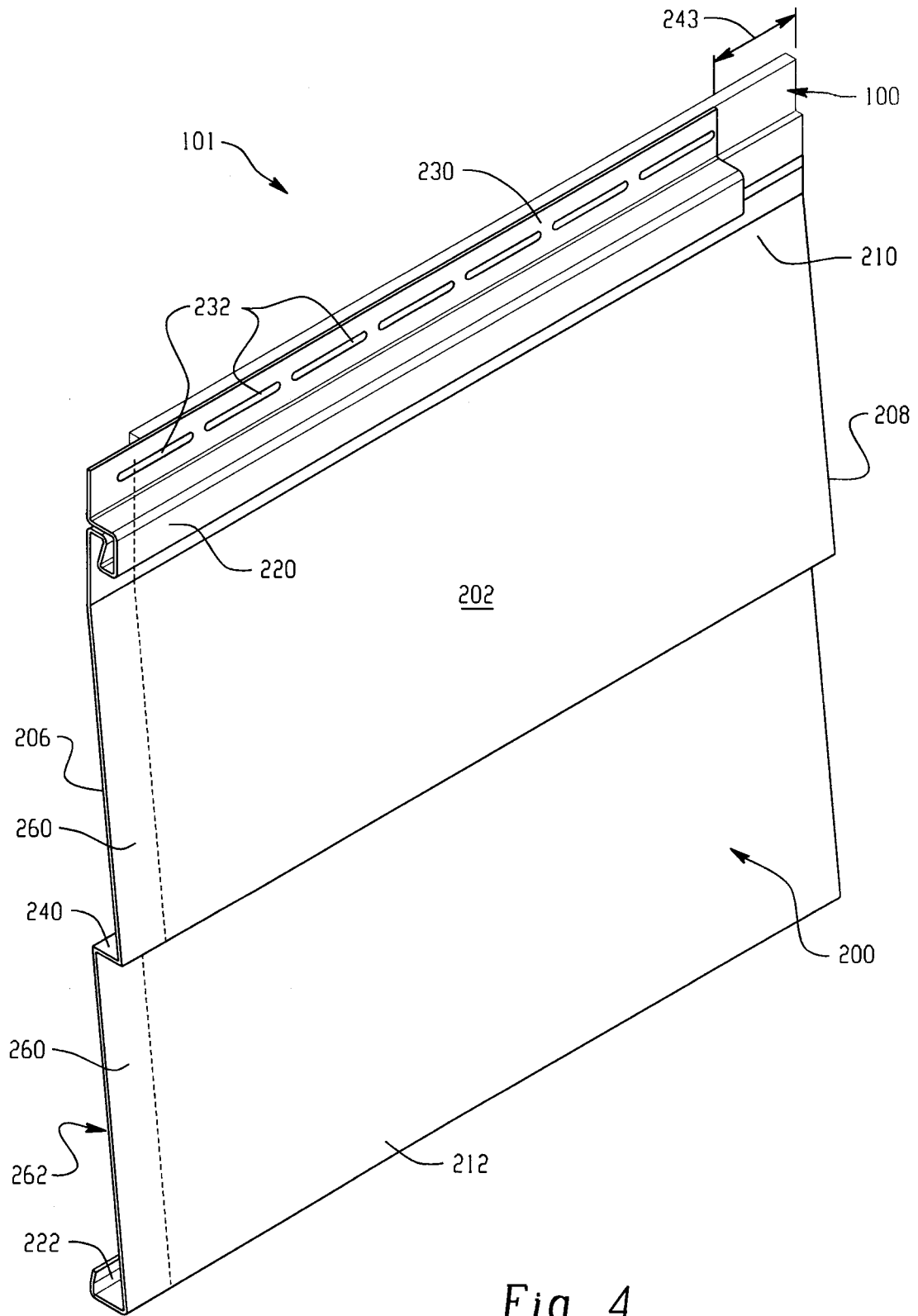

Fig. 4

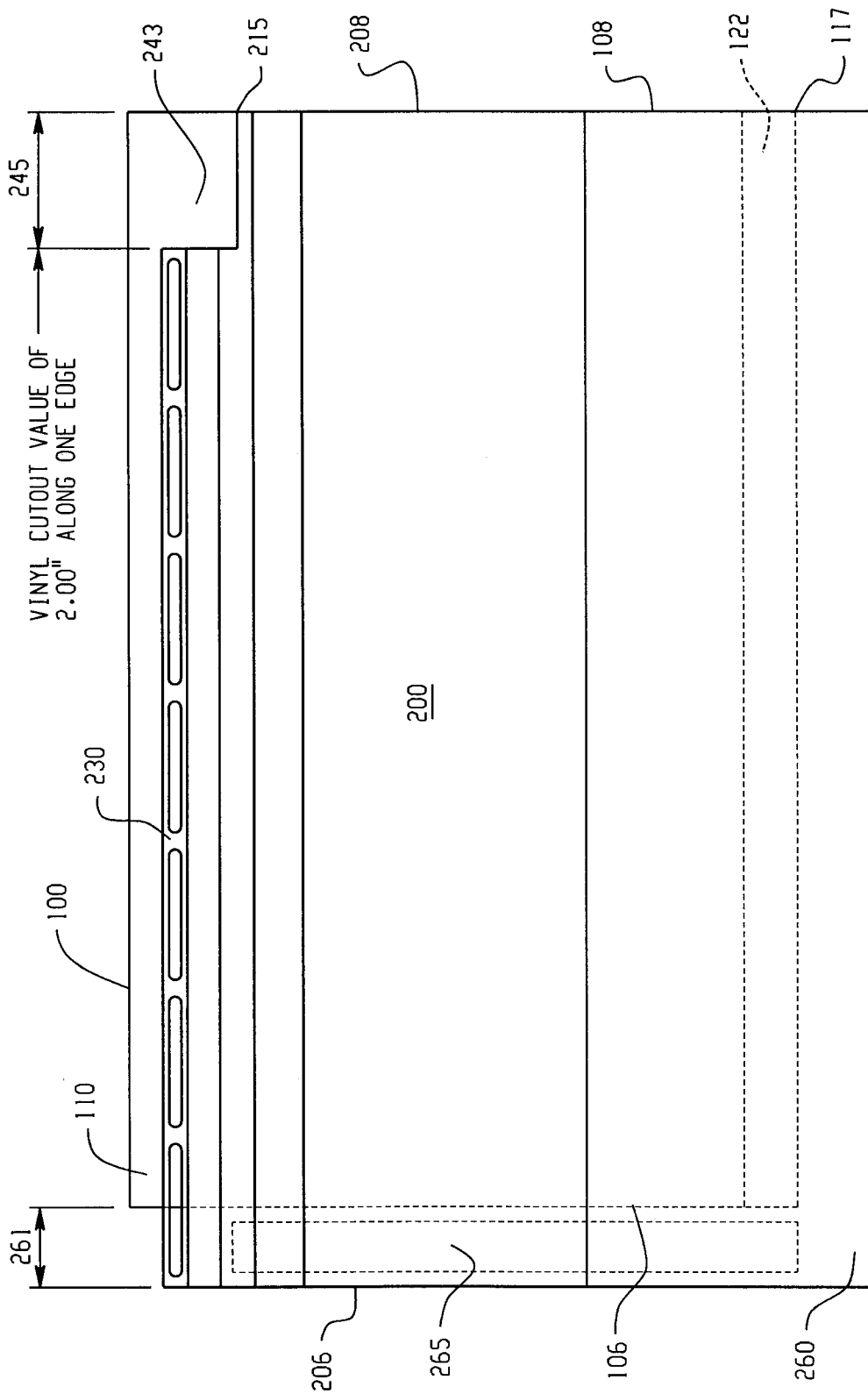

Fig. 5

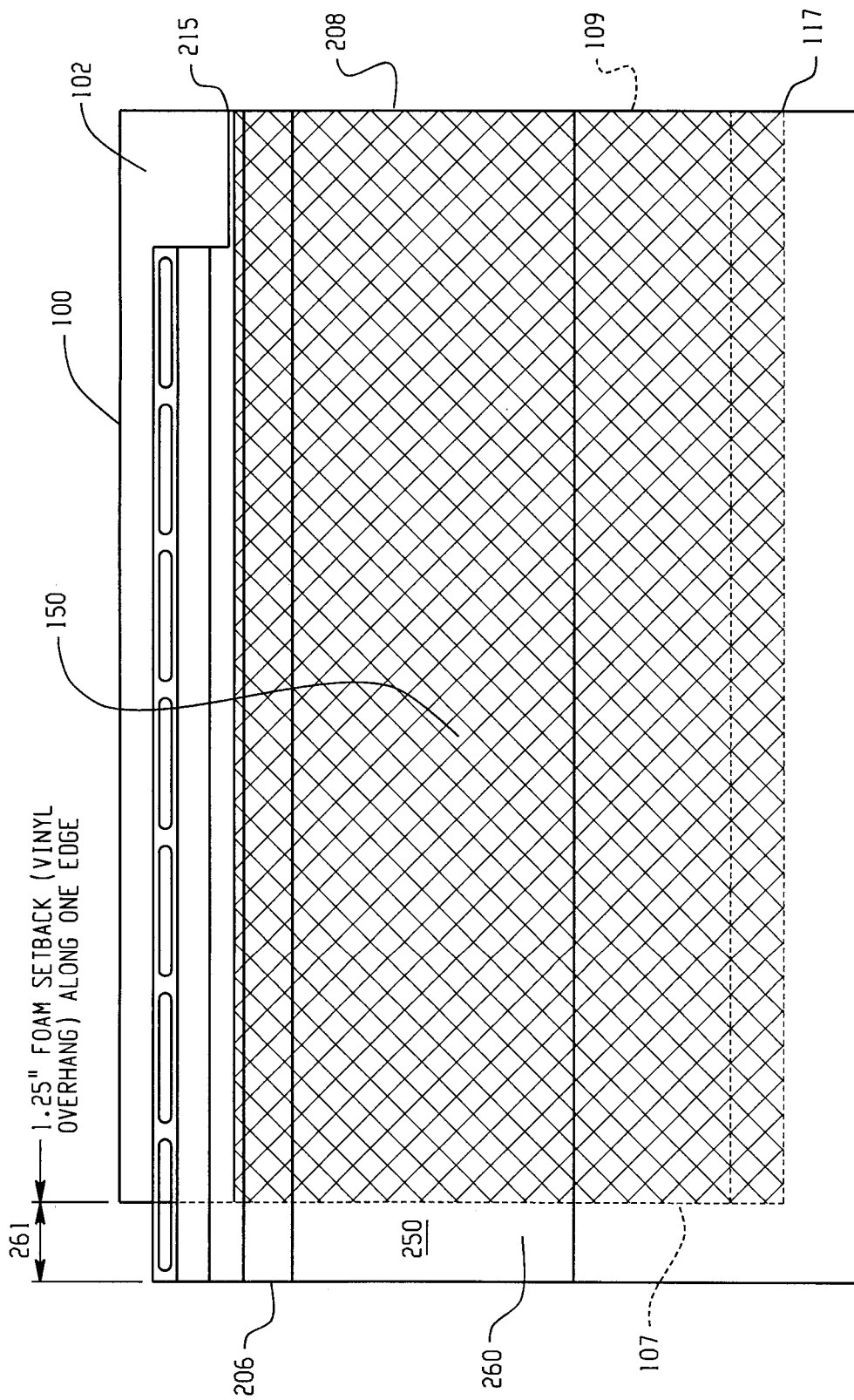

Fig. 6

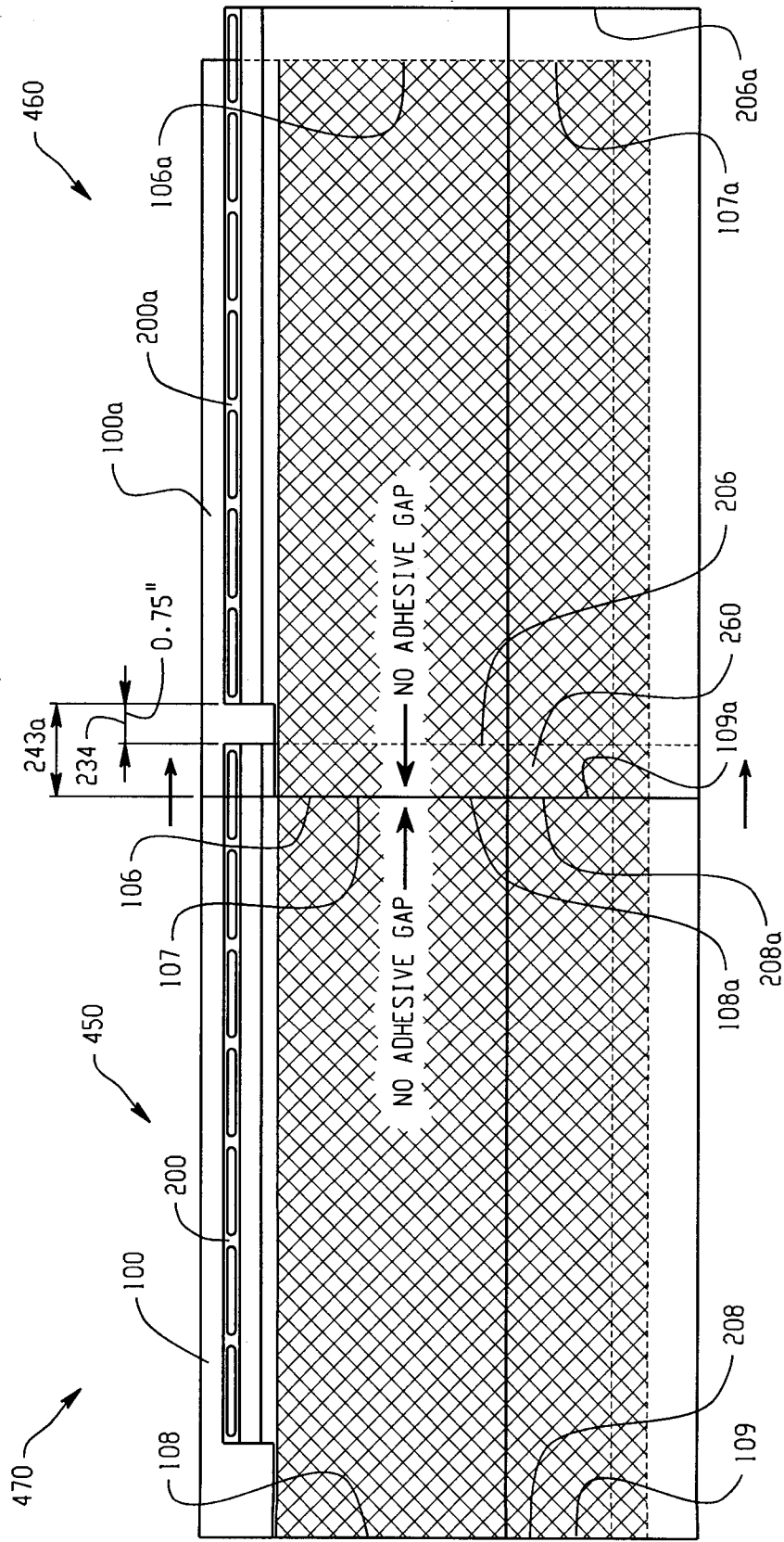

Fig. 7

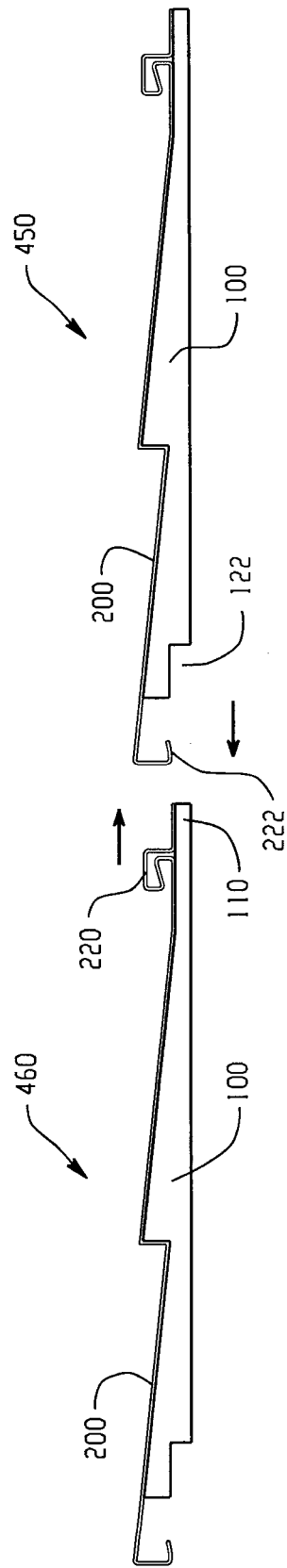

Fig. 8A

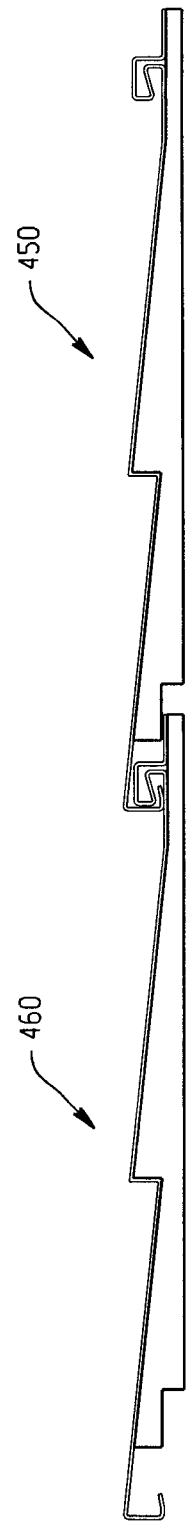

Fig. 8B

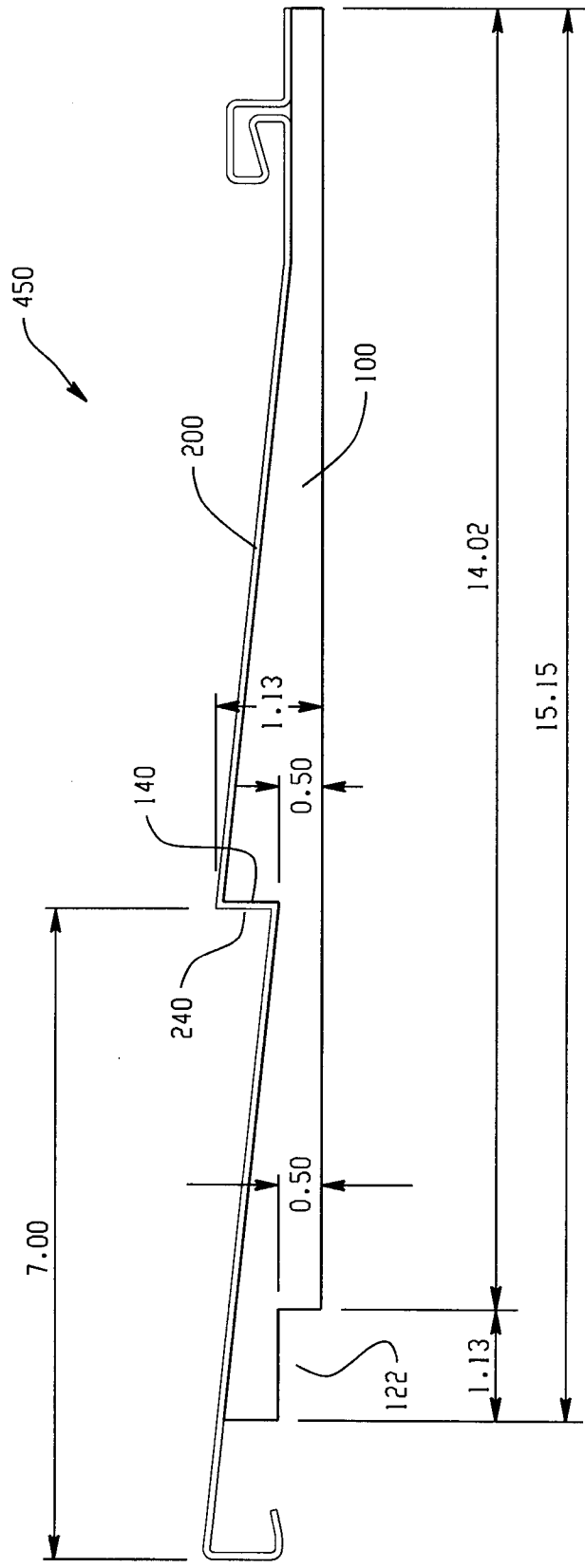

Fig. 9

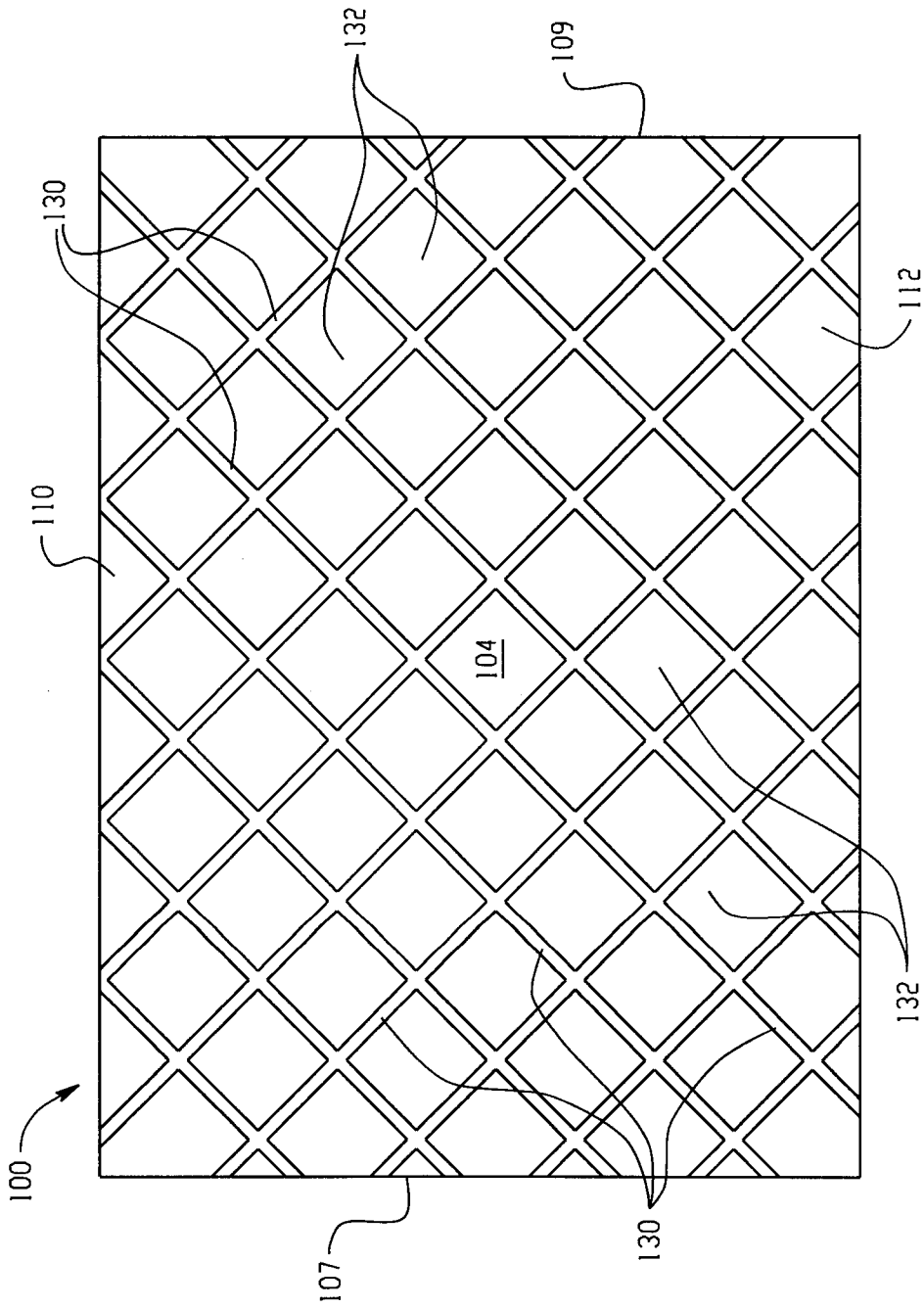

Fig. 10

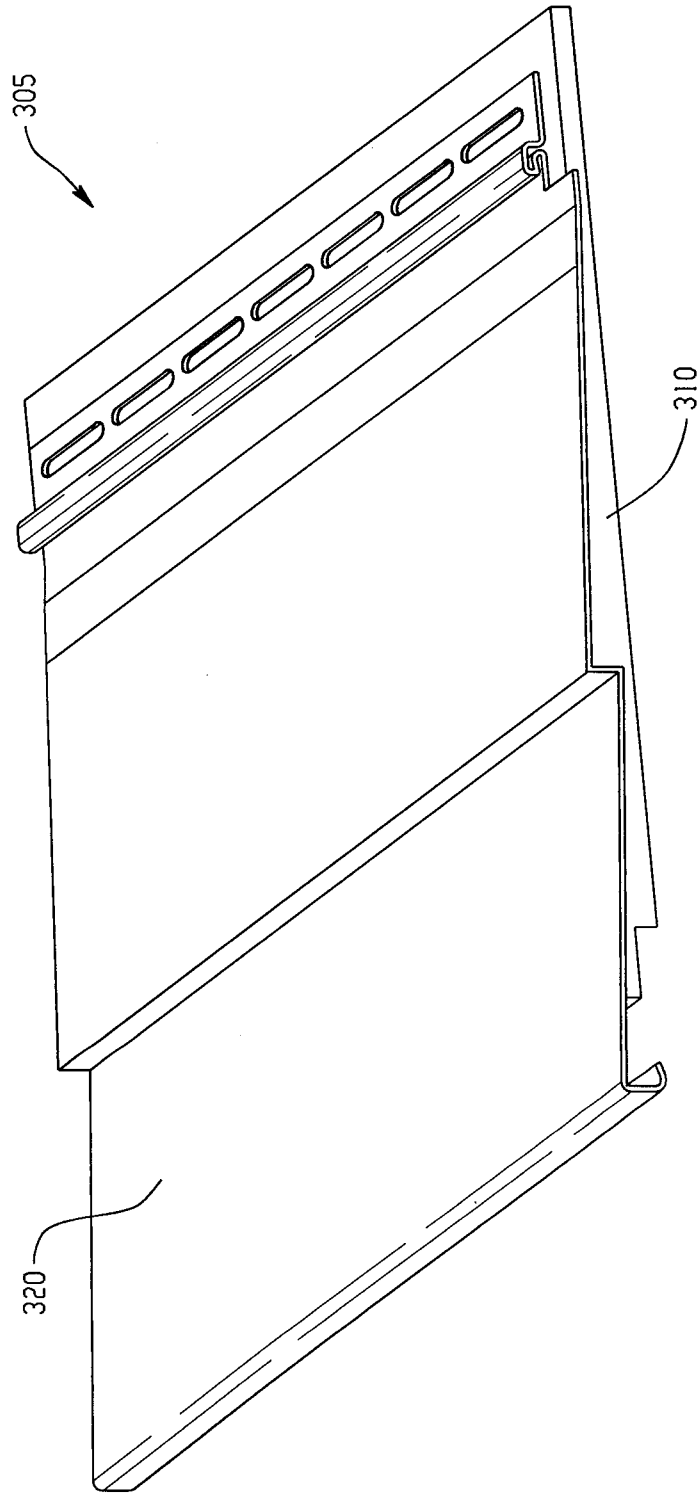

Fig. 11
PRIOR ART

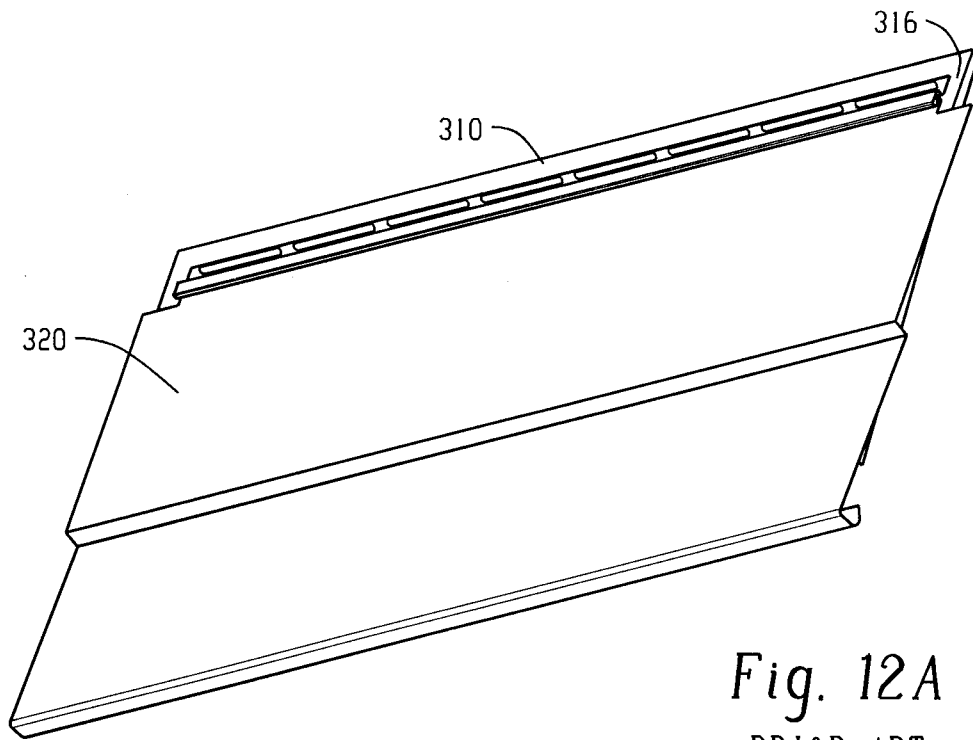

Fig. 12A
PRIOR ART

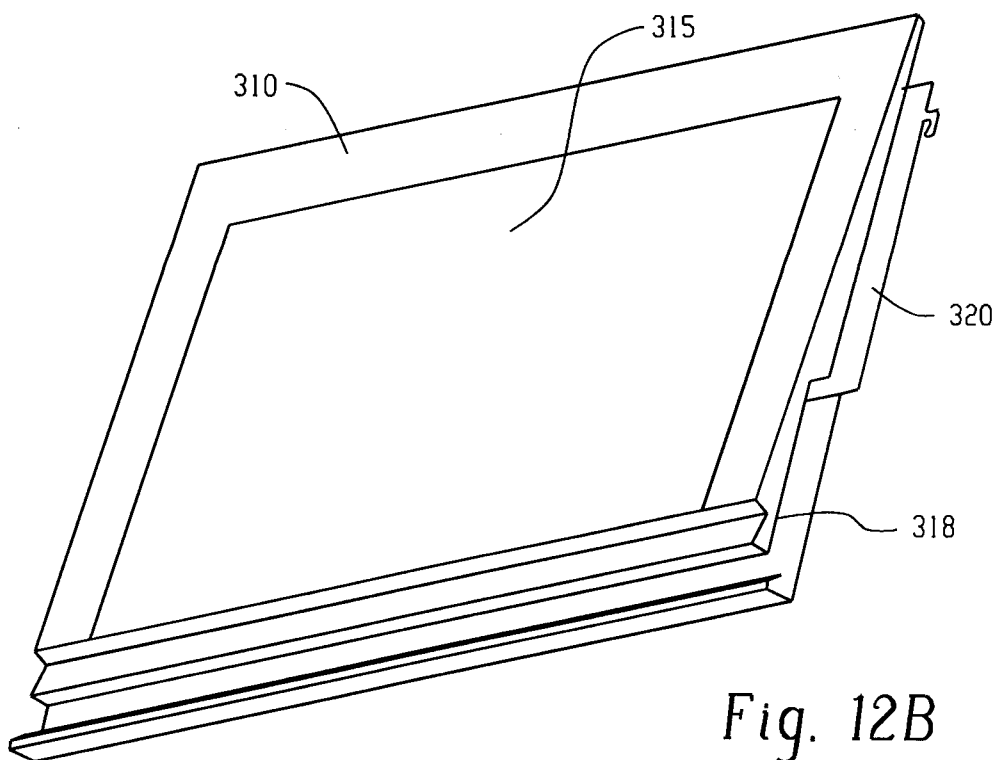

Fig. 12B
PRIOR ART

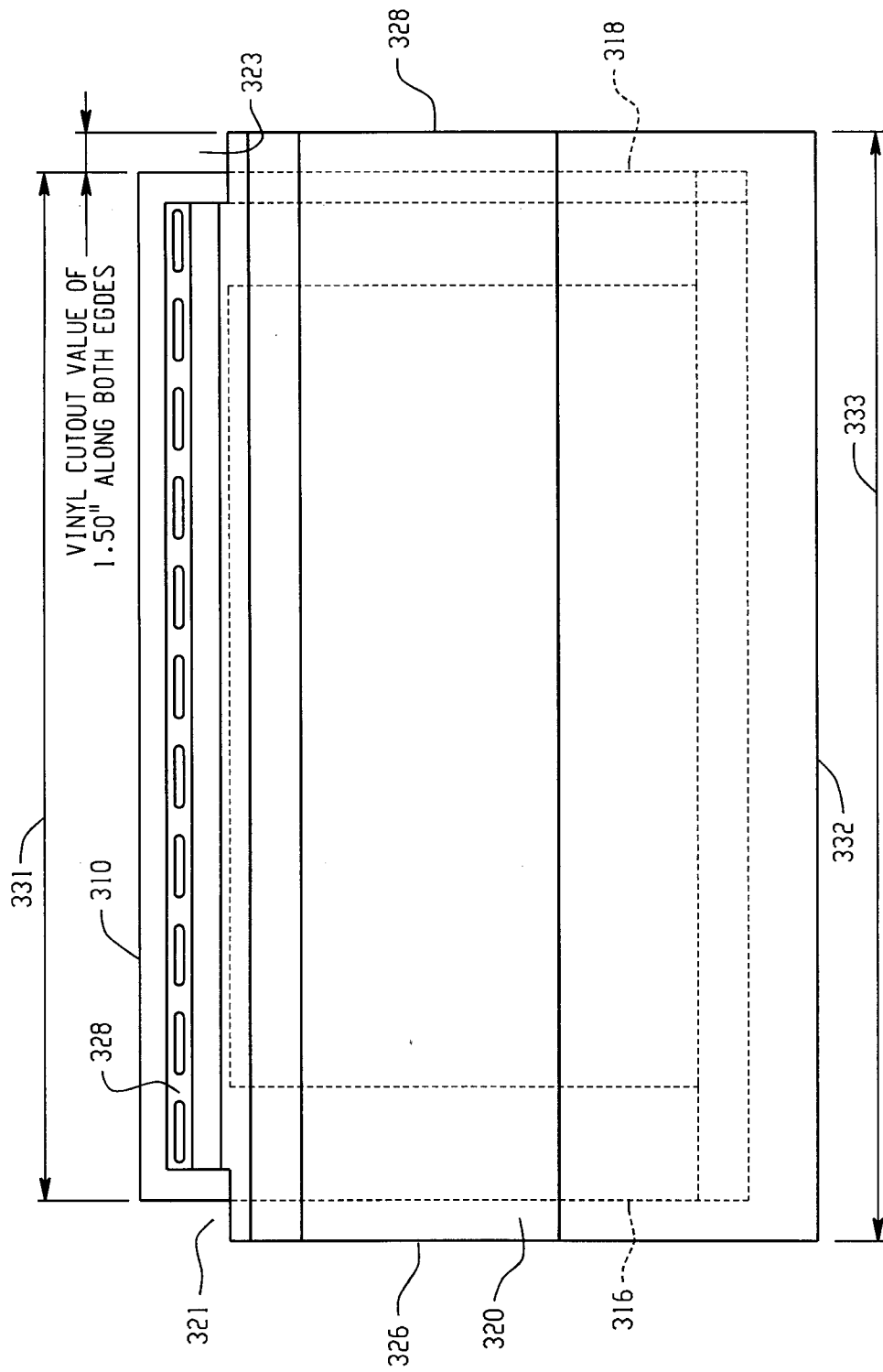

Fig. 13
 PRIOR ART

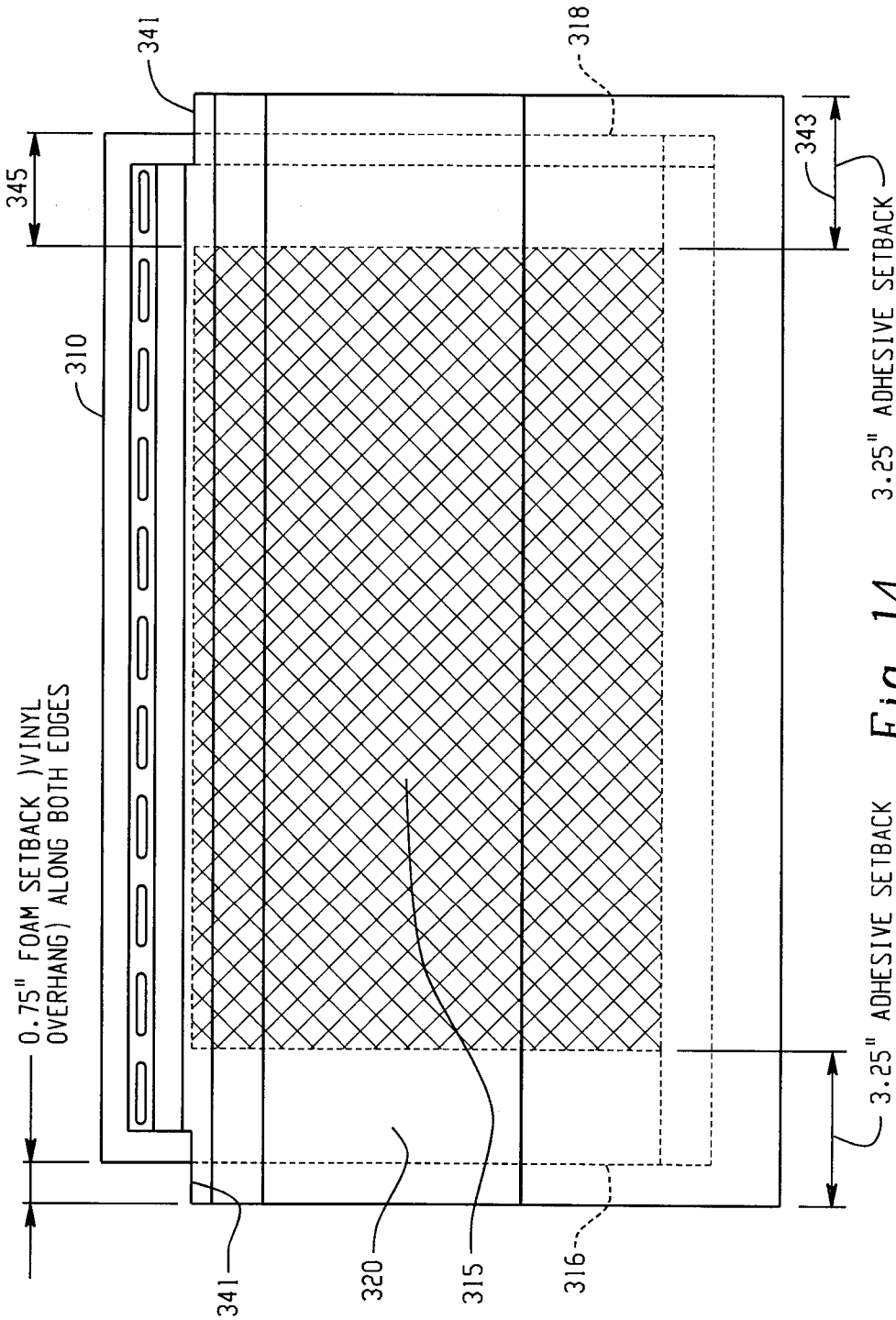

Fig. 14

3.25" ADHESIVE SETBACK

PRIOR ART

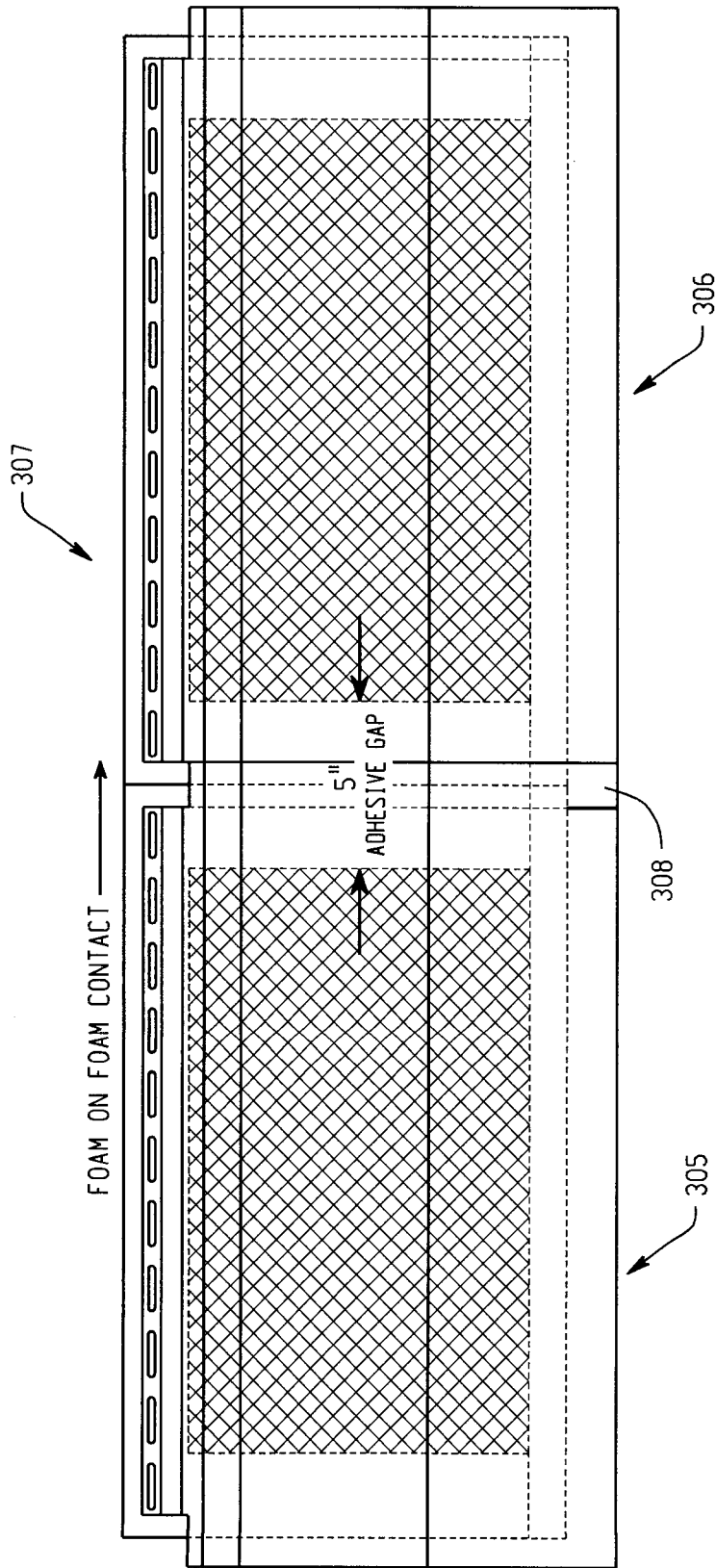

Fig. 15
PRIOR ART

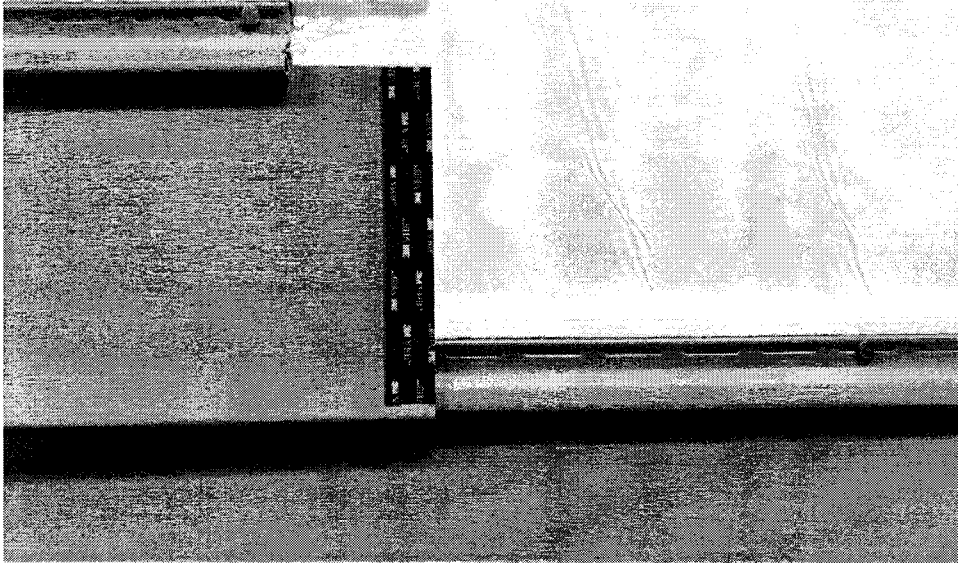

FIG. 16A

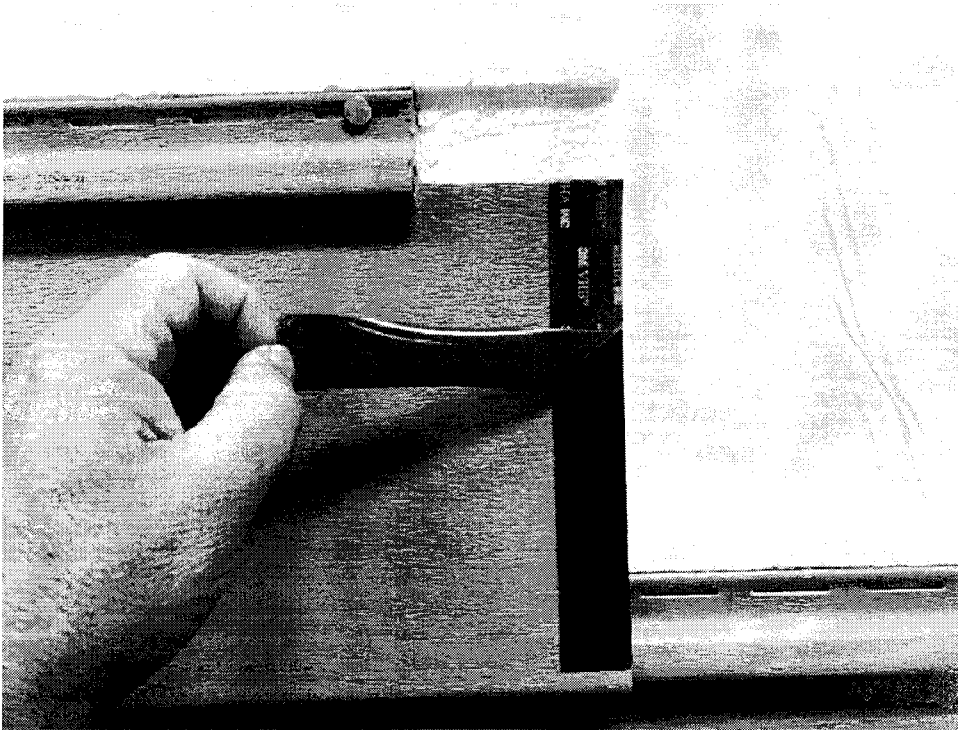

FIG. 16B

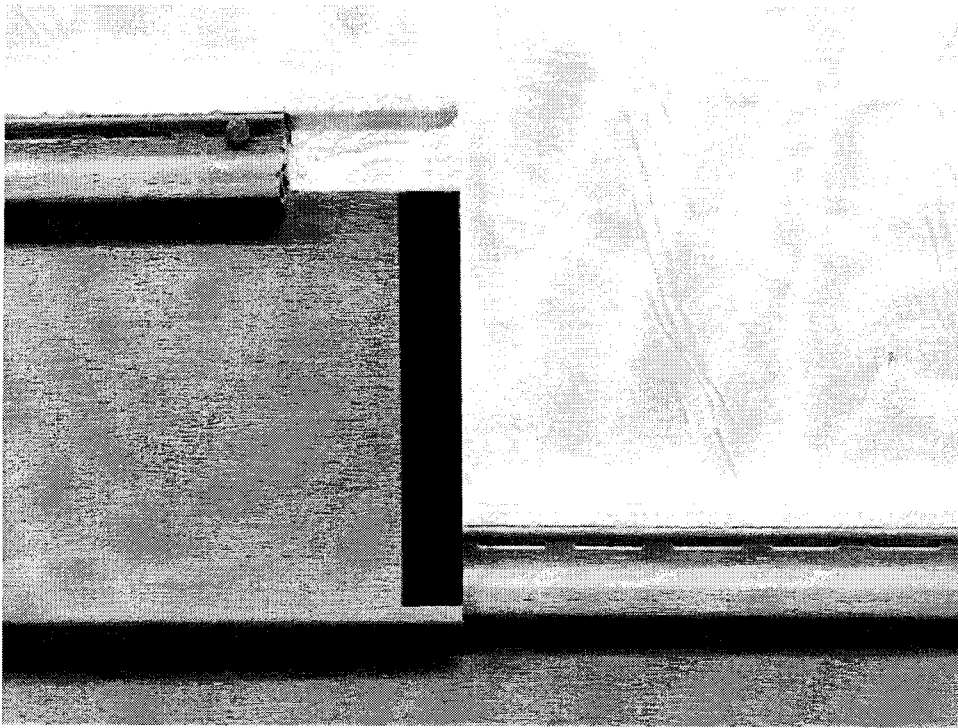

FIG. 16C

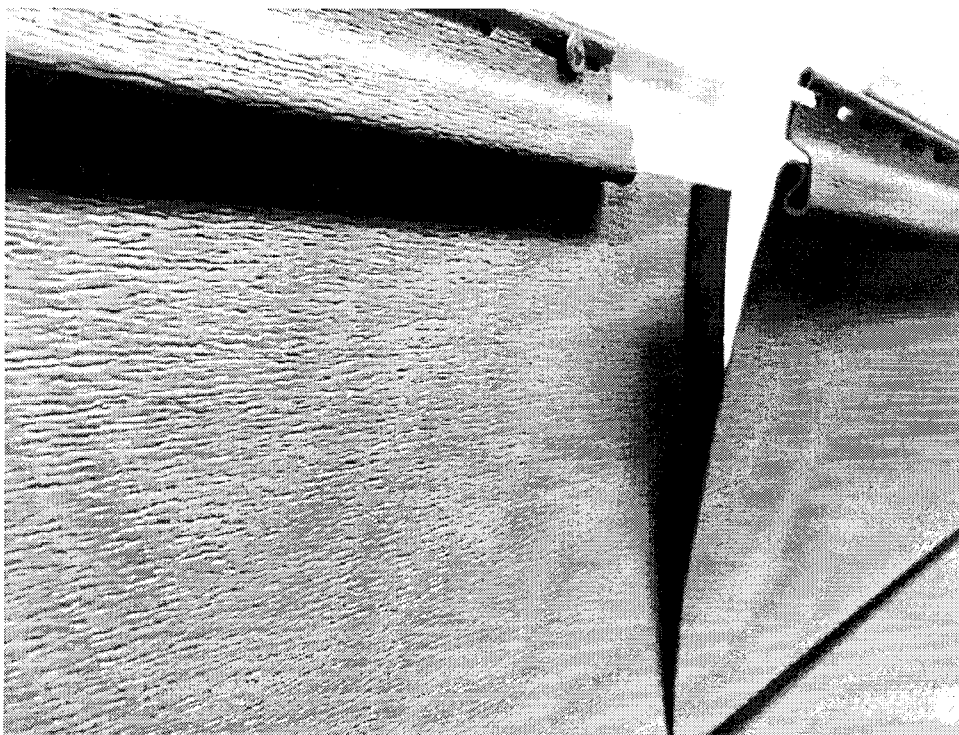

FIG. 16D

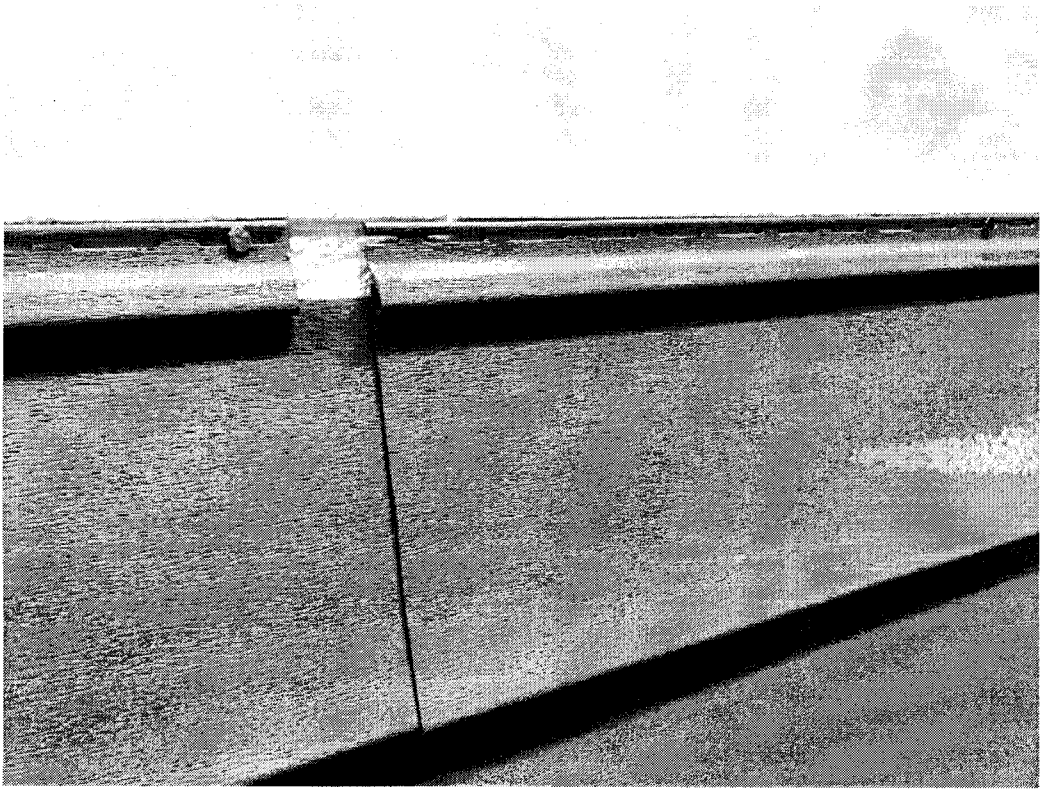

FIG. 16E

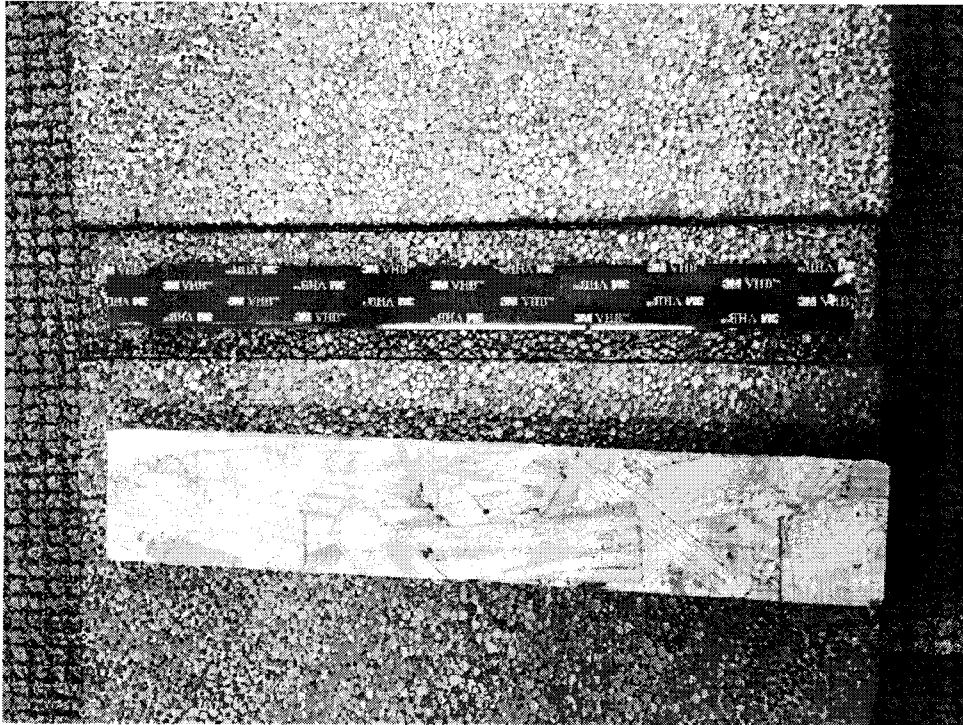

FIG. 17A

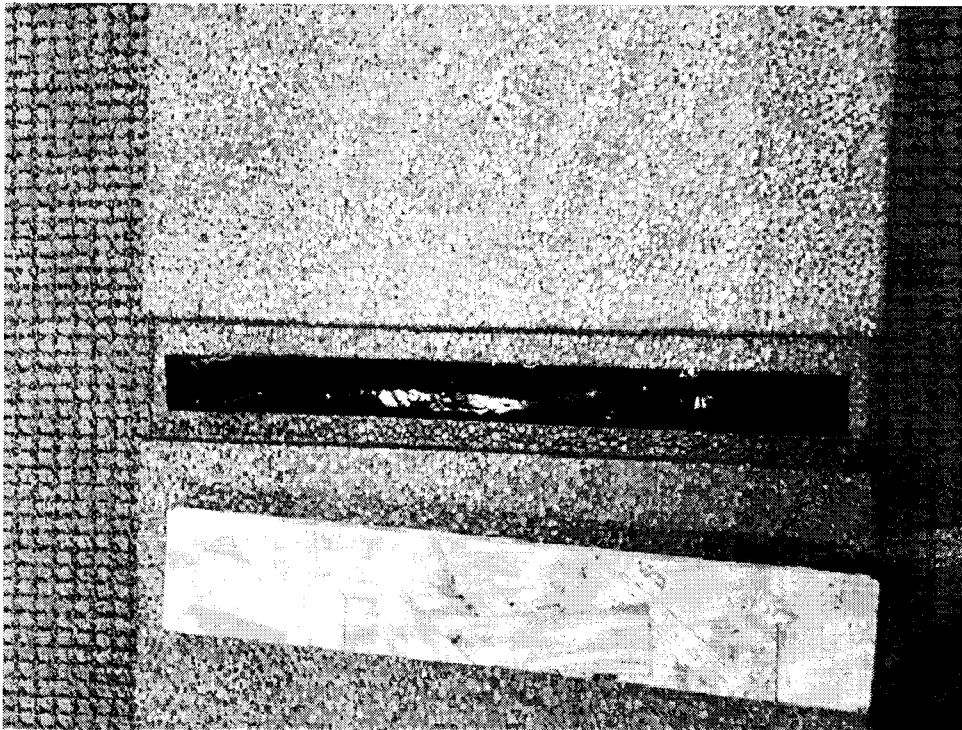

FIG. 17B

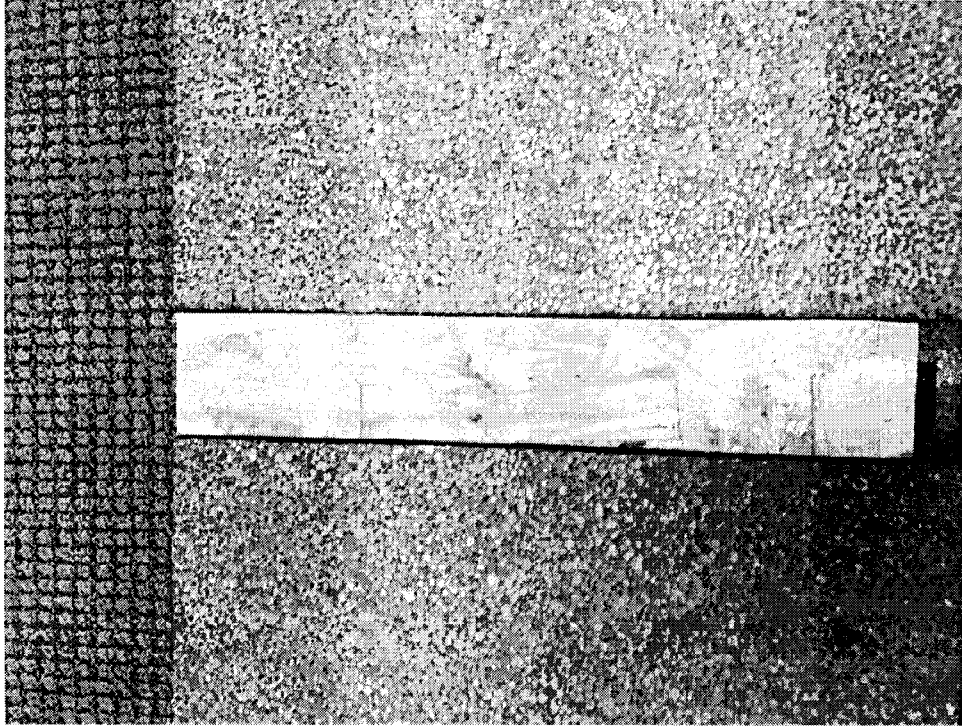

FIG. 17C

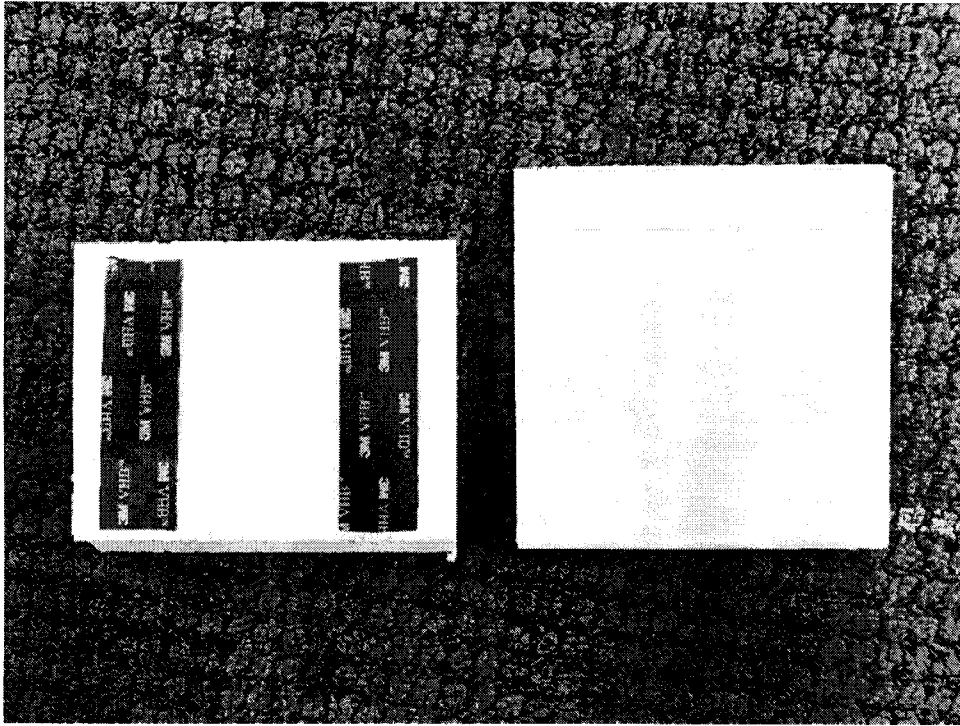

FIG. 18A

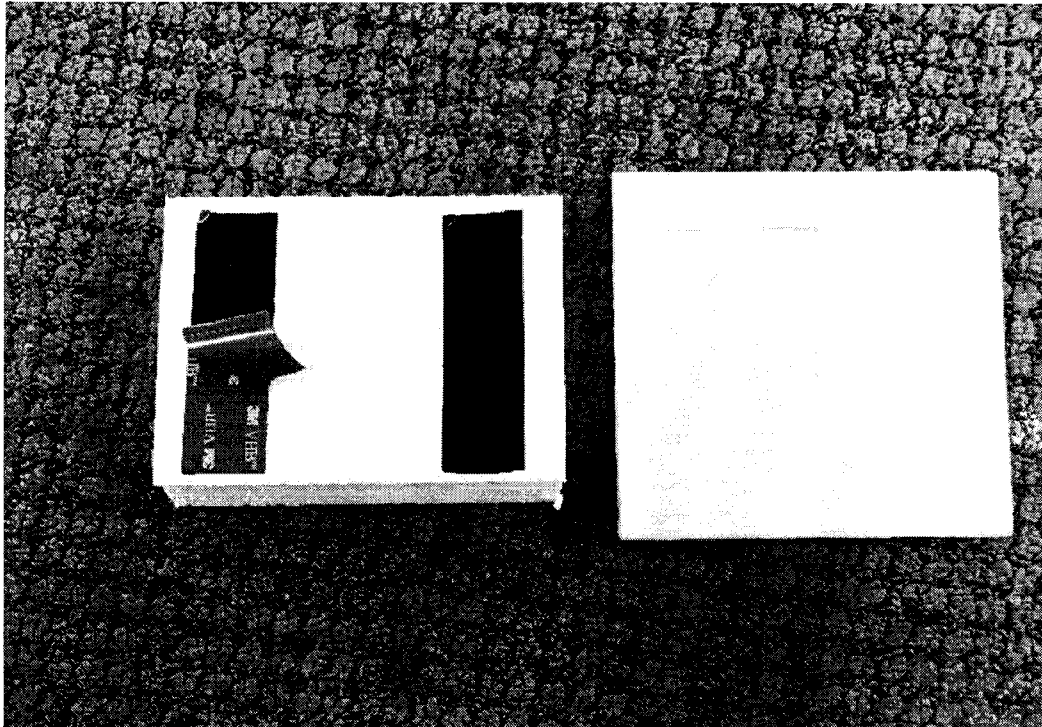

FIG. 18B

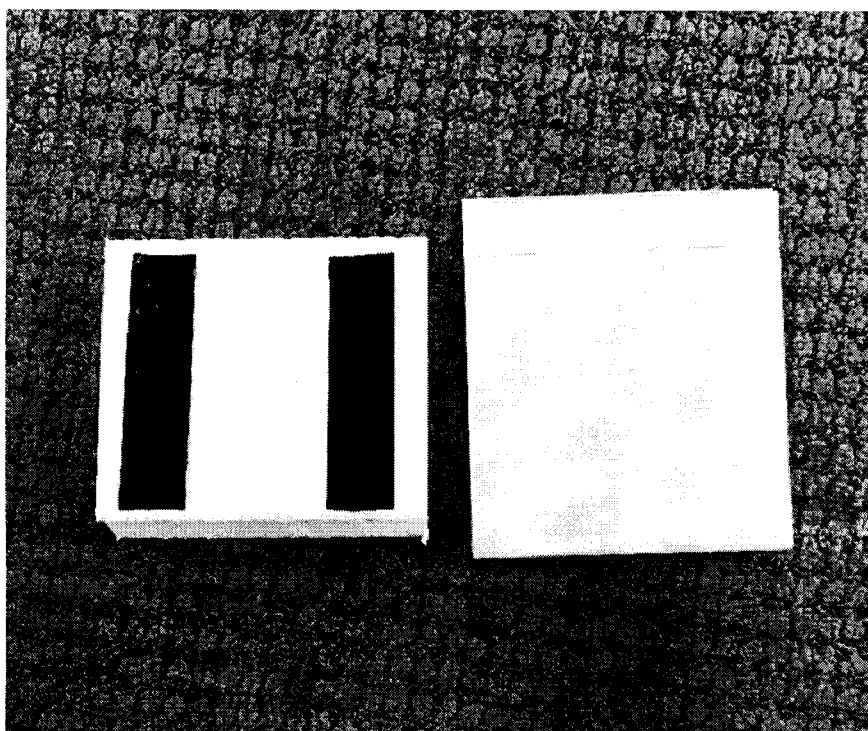

FIG. 18C

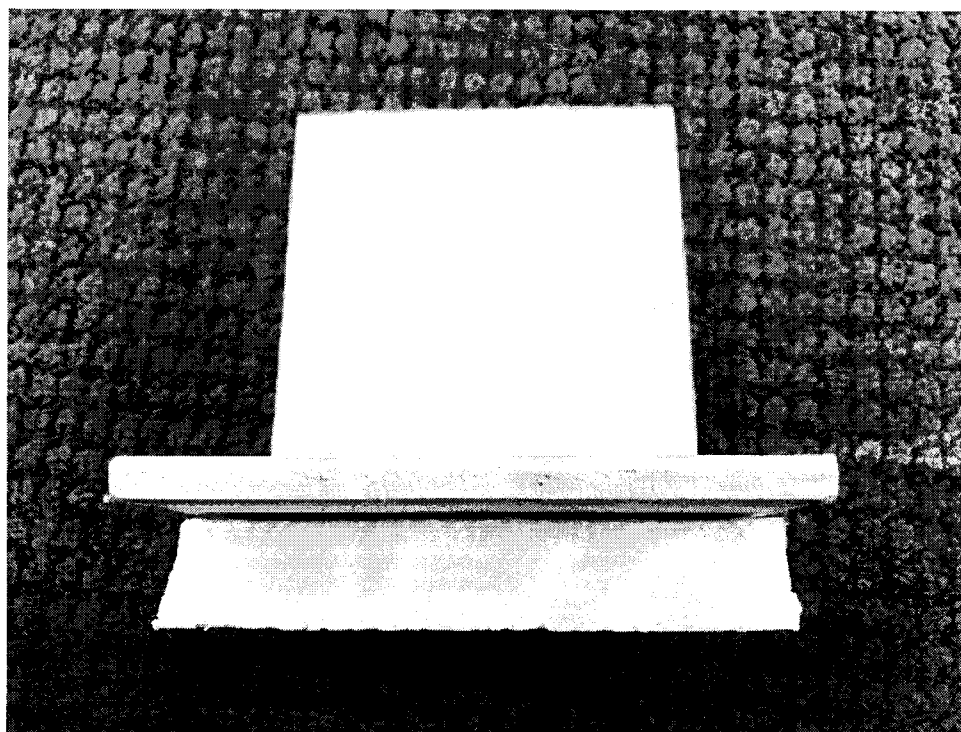

FIG. 18D

