

[54] **ELECTRICAL HEATING ENVELOPES**

[76] Inventor: **Jacques P. Thibault**, 24 Av. Theophile Gautier, Paris, France

[22] Filed: **June 28, 1971**

[21] Appl. No.: **157,551**

[52] U.S. Cl. **219/535, 219/430, 219/432, 219/433, 219/437, 219/439, 219/521, 219/530, 219/531**

[51] Int. Cl. **H05b 3/58**

[58] Field of Search **219/437, 439, 441, 219/462, 521, 528-529, 530, 535, 432, 433, 434, 435, 436, 438, 449, 450, 457, 245, 425, 552; 338/230**

2,482,665	9/1949	Geyer	219/529
2,607,876	8/1952	Bergen et al.....	219/535 X
2,643,324	6/1953	Goldstaub.....	219/529
2,739,220	3/1956	Morey.....	219/535
2,842,654	8/1958	Anderson.....	219/433
2,952,764	9/1960	Mimann.....	219/432
3,281,579	10/1966	Glichsmann	219/535
3,387,333	6/1968	Irvine et al.....	219/528 X
3,484,585	12/1969	Morey.....	219/535

FOREIGN PATENTS OR APPLICATIONS

780,085	7/1957	Great Britain	219/433
838,497	6/1960	Great Britain	219/528
169,295	10/1933	Switzerland.....	219/439

Primary Examiner—Volodymyr Y. Mayewsky
Attorney—Fishman & Van Kirk

[56] **References Cited**

UNITED STATES PATENTS

1,492,146	4/1924	Thornton, Jr.....	219/436
2,282,078	5/1942	Morey.....	219/436
2,215,042	9/1940	Howard et al.	219/529
2,739,221	3/1956	Morey.....	219/531
2,945,114	7/1960	Mathews.....	219/438 X
3,043,943	7/1962	Moot	219/449
3,086,385	4/1963	Branchereau et al.....	219/425 X
3,244,861	4/1966	Colburn.....	219/438
3,393,292	7/1968	Ritscher.....	219/245

[57] **ABSTRACT**

An electrical heating envelope which includes a metallic layer interposed between a vessel, the contents of which are to be heated, and the heating elements which supply the thermal energy. The metallic layer will typically be comprised of non-magnetic material and a layer of resilient insulating material may be positioned between the plate and vessel.

4 Claims, 2 Drawing Figures

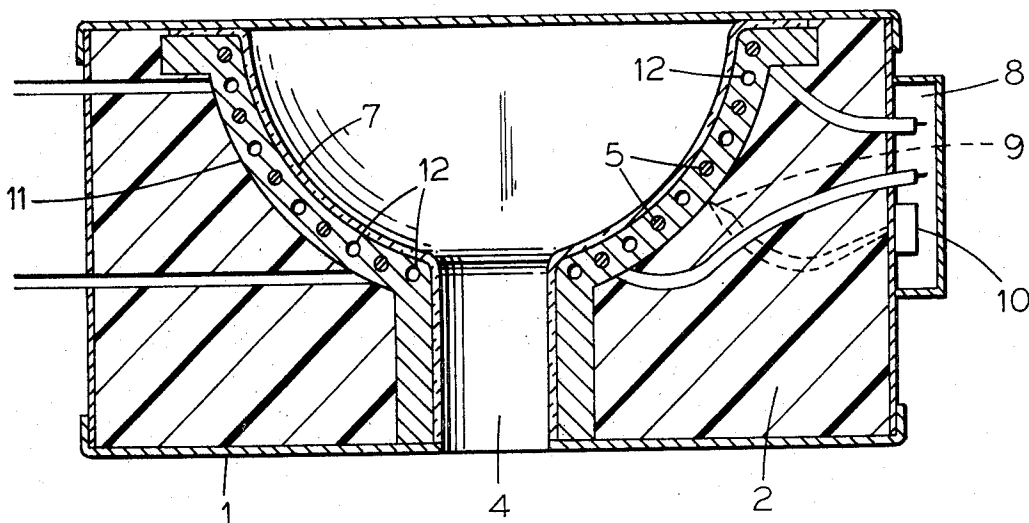

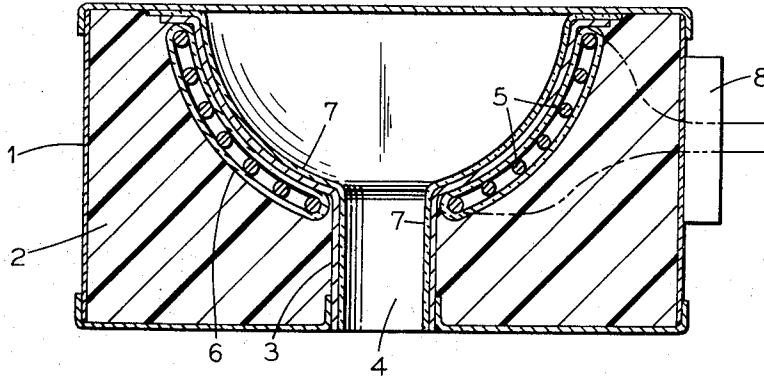

FIG. 1

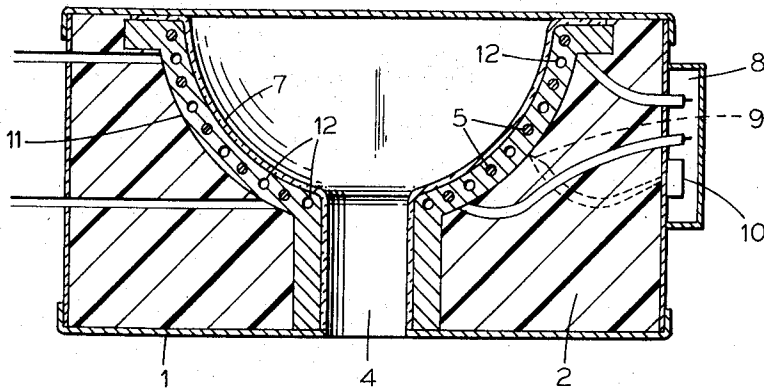

FIG. 2

ELECTRICAL HEATING ENVELOPES**BACKGROUND OF THE INVENTION****1. Field of the Invention**

The present invention relates to heating of the contents of vessels such as, for example, containers comprised of glass. More specifically, this invention is directed to electrical heating envelopes for industrial or domestic use. Accordingly, the general objects of the present invention are to provide novel and improved methods and apparatus of such character.

2. Description of the Prior Art

Methods of and apparatus for electrically heating the contents of a flask or other container are well known in the art. The typical prior art device will comprise a generally cylindrical shaped outer envelope which may, for example, be comprised of aluminum. The envelope forms a housing for resistors which function as heating elements. The resistors are usually insulated by glass or asbestos braiding and are sewn within asbestos fabric placed between two glass fiber layers. The insulating and supporting medium for the resistors is positioned in such a manner as to distribute the resistors regularly about the entire lower surface of a vessel which may receive the substances to be heated.

The prior art heated envelopes of the type briefly discussed above are characterized by a number of well known deficiencies. Firstly, the heat transfer efficiency of these devices is not particularly high. Secondly, in cases where the actual container for the material to be heated is comprised of a material such as glass which fractures easily, the prior art devices provide no protection for the heating elements which may become damaged by the contents of the container in the case of a container wall failure.

Further deficiencies of prior art heating envelopes include the fact that they typically are not flameproof and therefore pose a safety hazard. Also, in the interest of regulating the operating temperature, prior art heating envelopes have provided only for the control of current to the heating elements or resistors. Considering the mass of the resistors, this is at best a slow control method which is lacking in precision.

SUMMARY OF THE INVENTION

The present invention overcomes the above discussed and other deficiencies and disadvantages of the prior art by providing a novel and improved technique for electrically heating the contents of containers and a heating envelope for use in the practice of such technique. In accordance with the present invention, a metallic plate member is interposed between the heating elements and the recipient of the heat. The metallic plate member will preferably be comprised of a non-magnetic material and a sheet of insulating fabric may be positioned between the plate and heat recipient.

In accordance with one embodiment of the invention, the metallic plate member is in the form of a block which is sufficiently thick so as to enable the heating element resistors to be embedded therein. The block may also be provided with passages through which a coolant may be circulated in the interest of temperature control. Also in the interest of temperature control, the invention may include a thermocouple or equivalent device which senses the temperature of the metallic plate and, through appropriate circuitry, regulates the flow of current to the heating elements and/or

the flow of coolant through the passages in the metallic plate member.

BRIEF DESCRIPTION OF THE DRAWING

The present invention may be better understood and its numerous objects and advantages will become apparent to those skilled in the art by reference to the accompanying drawing wherein like reference numerals refer to like elements in the several figures and in which:

FIG. 1 is a cross-sectional, side elevation view of a first embodiment of the invention; and

FIG. 2 is a cross-sectional, side elevation view of a second embodiment of the invention.

DESCRIPTION OF THE PREFERRED EMBODIMENTS:

With reference now to FIG. 1, the housing for the heating appliance of the present invention is indicated at 1. Housing 1, which may be comprised of any suitable material, will typically have a cylindrical outer shape and the voids therein will be filled with a thermal insulating material 2 of glass wool or other equivalent material.

A non-magnetic sheet metal member 3 is shaped so as to provide a seat for a container, not shown, which will function as the recipient of heat produced by the present invention. Thus, by way of example, plate 3 may be contoured so as to receive a glass flask and the plate may be provided with a tubular neck receiving portion 4 which accepts the tubular necks with which certain flasks are provided.

The heating element for the embodiment of FIG. 1 comprises a plurality of resistors 5 which are sewn, in a manner well known in the art, into and enveloped by an asbestos sheet 6. The metallic member 3 is covered by another asbestos sheet member 7 which prevents contact between the heat recipient and the heated metallic member 3. Asbestos sheet 7 also compensates for small differences in shape and size between the recipient container and the contour of member 3.

Electric current for heating purposes is delivered to the resistors 5 via a standard connector 8. The delivery of current to the resistors and the operation of the invention are in accordance with well known technology and will not be described herein.

Referring now to FIG. 2, the second disclosed embodiment of the invention will be described only insofar as it departs structurally from the previously described embodiment. A principal difference between the embodiments of FIGS. 1 and 2 is that the non-magnetic sheet metal member 3 is in the form of a block 11 in the FIG. 2 embodiment. As shown, in the FIG. 2 embodiment the metallic block 11 will be sufficiently thick so as to enable the resistors 5 to be embedded therein. The metallic block may be obtained by casting or by metalization; that is, by pulverizing the material on a bed of fabric which is preferably the insulating fabric, the electrical resistors becoming embedded during the pulverization. The metallic block may also be produced by other equivalent processes.

Also in accordance with the FIG. 2 embodiment, the member 11 may be provided with a refrigeration circuit defined by tubes or passages 12 formed in or enveloped by the material which defines the block 11. A coolant may be circulated through passages 12 when it is de-

sired to rapidly reduce the temperature of member 11 and the contents of the heat recipient container.

It is to be noted that the asbestos sheet member 7 of the FIG. 2 embodiment may be either separate from the member 11 or may be integral therewith depending upon the method of manufacture employed in the fabrication of the metal block.

As shown in FIG. 2, the connector 8 is liquid-tight and flameproof. The connector housing contains a conventional temperature regulator 10 which is supplied with an input signal from a thermocouple 9; thermocouple 9 either being embedded in member 11 or in contact with an inner surface of metal member 11. The operation of and circuitry comprising temperature regulator 10 are in accordance with the state of the art and will not be described in detail herein. It is to be noted, however, that the thermocouple and regulator provide for the automatic control of the extent of heating through controlling the delivery of current to the heating elements. In this manner, the temperature of the applicance may be maintained below the minimum temperature above which a flash may be produced. A flash could result either through breakage of the heated recipient flask or by passage of vapors escaping from the flask into contact with the block 11.

If deemed desirable, the regulator 10 may also be employed to control the flow of coolant through the passages 6.

As will now be obvious to those skilled in the art, the present invention provides for better protection of the heating resistors in the case of breakage of the heat recipient container. Similarly, the use of a non-magnetic heat transfer member, in the nature of metal member 3 and 11, permits agitation to be affected from below by magnetic means. The asbestos sheet 7 prevents direct contact between the heated surface of metal members 3 and 11 and the walls of the recipient container.

While preferred embodiments have been shown and described, various modifications and substitutions may

be made thereto without departing from the spirit and scope of the present invention. Thus, while the invention has been described in the environment of a heating envelope for delivering thermal energy to flasks and other containers, it may be applied to such devices as heated reactors, heated funnels, heated mufflers, heated feeding bottles, heated basins, heated fondues and other devices. Accordingly, it is to be understood that the present invention has been described by way of illustration and not limitation.

What is claimed is:

1. An electrical heating envelope for supporting and heating containers comprising:

a housing;
vessel receiving means disposed within said housing, said vessel receiving means having a first surface which defines a recess shaped to receive a container to be heated, said receiving means being comprised of thermal insulating material;

electrically energized heating means positioned on and substantially conforming to said receiving means first surface, said heating means comprising a plurality of resistors embedded in a metallic layer; and

a layer of thermal insulating fabric material coating the external surface of said heating means metallic layer whereby containers to be heated are disposed in said recess on said fabric material coating.

2. The apparatus of claim 1 further comprising: means for sensing the temperature of said metallic layer and for generating a signal commensurate therewith.

3. The apparatus of claim 2 wherein said temperature sensing means comprises a thermocouple embedded in said metallic layer.

4. The apparatus of claim 1 wherein said metallic layer defines a path for the circulation of a coolant.

* * * * *

40

45

50

55

60

65