



US 20040259663A1

(19) **United States**

(12) **Patent Application Publication**
Grim

(10) **Pub. No.: US 2004/0259663 A1**

(43) **Pub. Date: Dec. 23, 2004**

(54) **IMPACT POINT DEVELOPMENT FOR GOLF CLUBS**

(60) Provisional application No. 60/295,882, filed on Jun. 5, 2001.

(76) Inventor: **Earl Grim**, Dordentown, NJ (US)

Publication Classification

Correspondence Address:
Eugene E. Renz, Jr., P.C.
205 North Monroe Street
Post Office Box 2056
Media, PA 19063-9056 (US)

(51) **Int. Cl.⁷** **A63B 53/02; A63B 53/04**

(52) **U.S. Cl.** **473/314; 473/324; 473/345**

(57) **ABSTRACT**

A golf club comprising an elongated shaft, a club head at one end of the shaft having a face, a heel portion, a toe portion and a sole portion; a lie angle configured to maintain the impact point of a golf ball on the club face when the impact point is offset from the center of mass, said lie angle being the angle subtended by the axis of the shaft and a horizontal plane tangent to the sole of the club wherein the sole of the club at the point where a vertical line through the club head center of gravity intersects said sole.

(21) Appl. No.: **10/800,527**

(22) Filed: **Mar. 15, 2004**

Related U.S. Application Data

(63) Continuation of application No. 10/162,959, filed on Jun. 5, 2002, now abandoned.

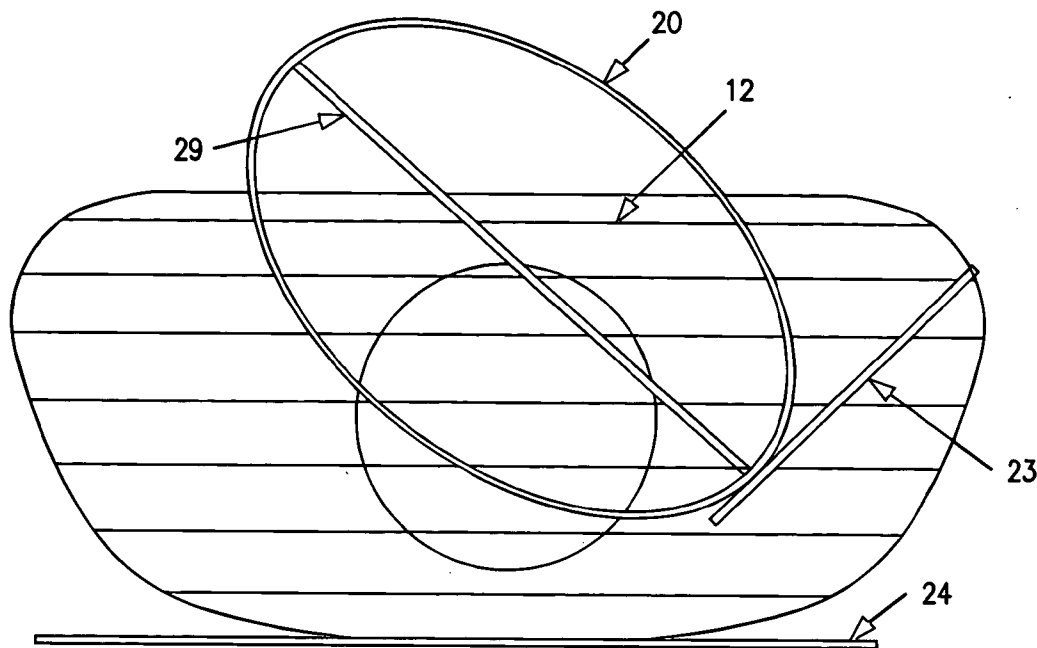

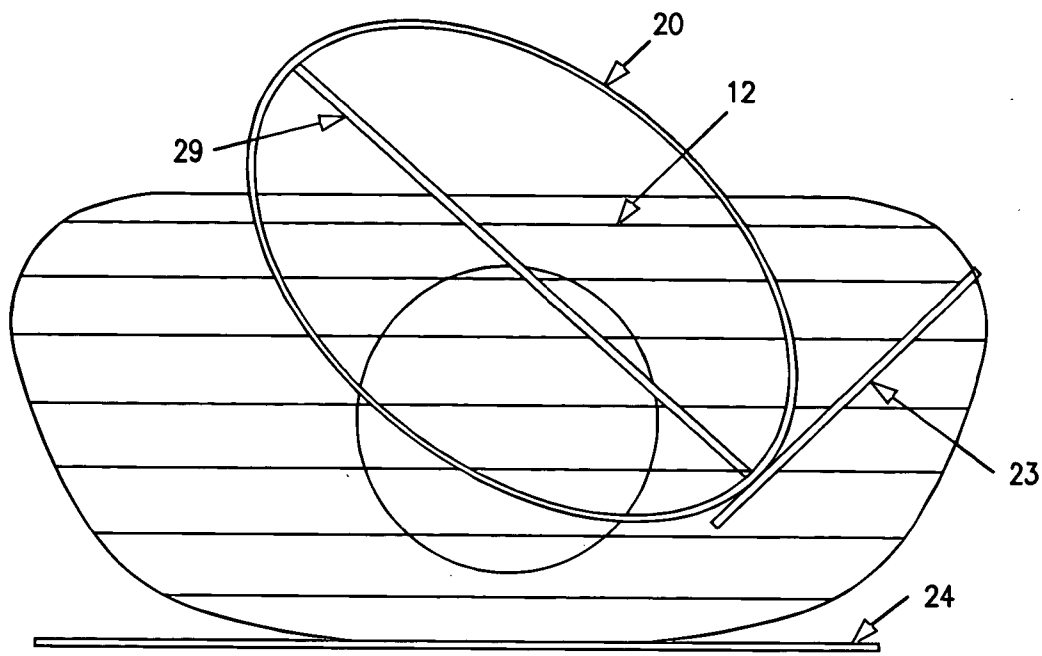

FIG. 1

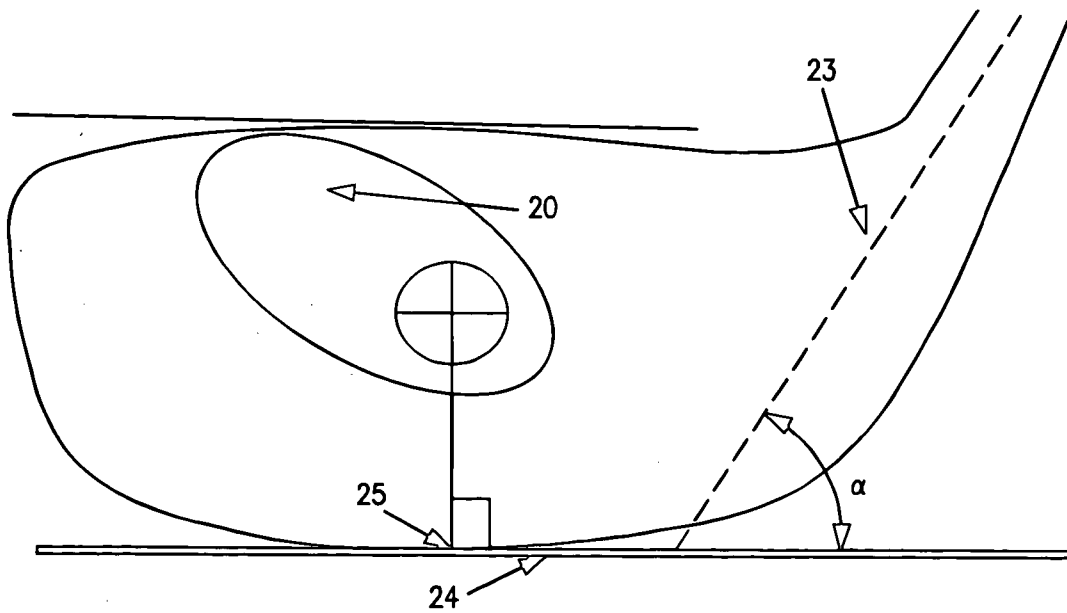

FIG. 2

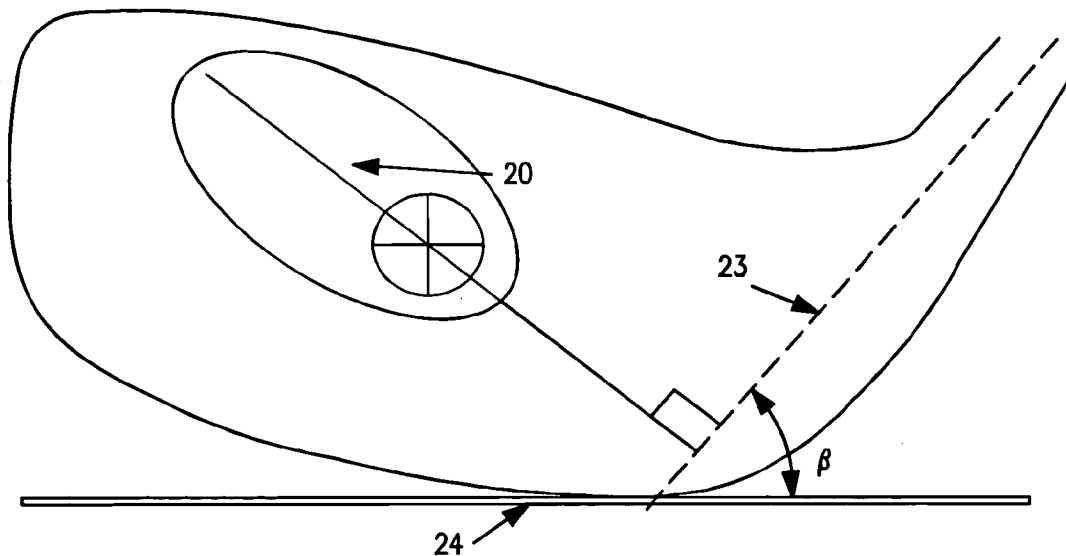

FIG. 3

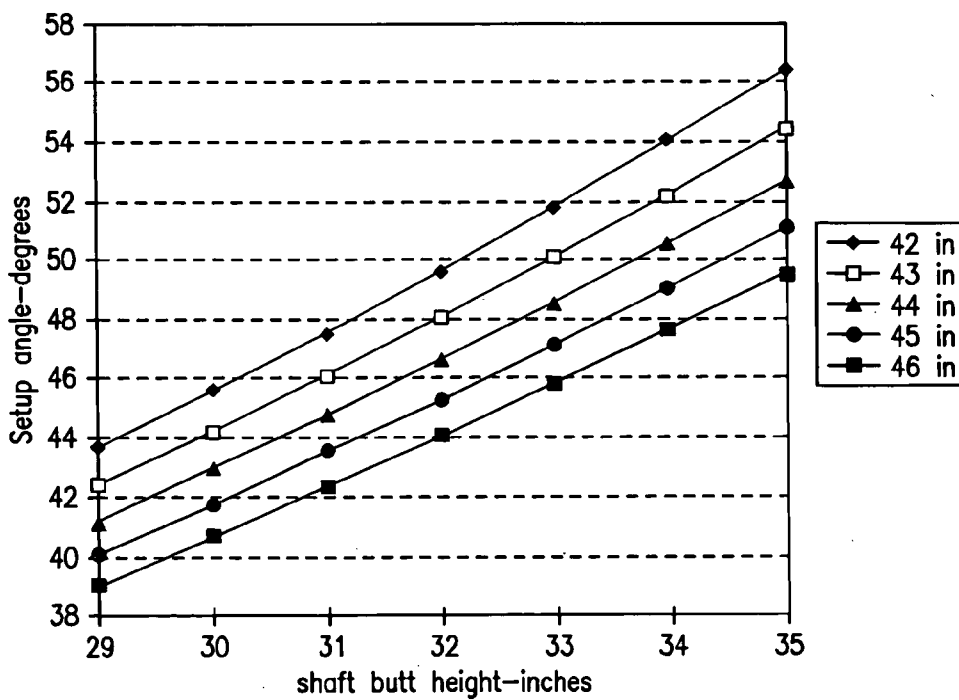

FIG. 4

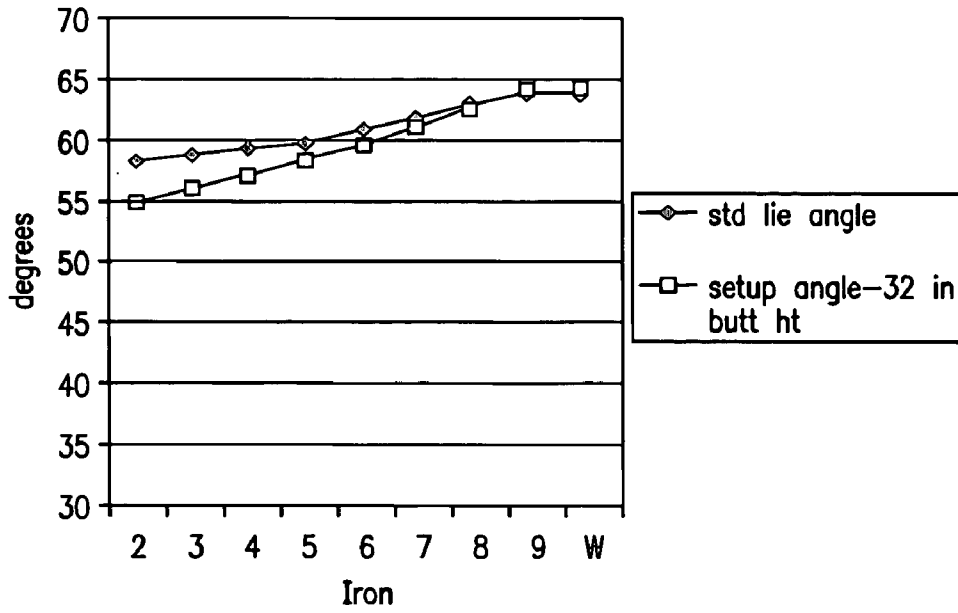

FIG. 5

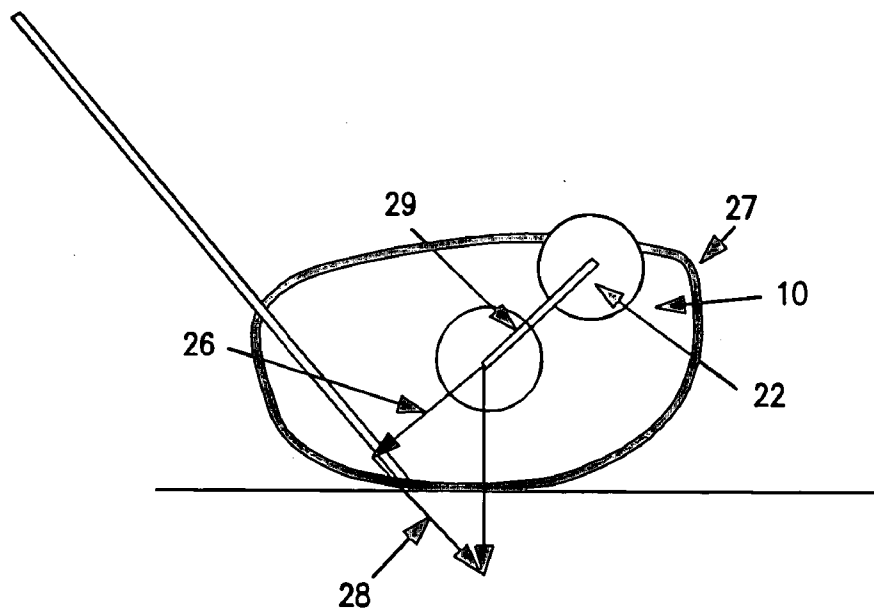

FIG. 6

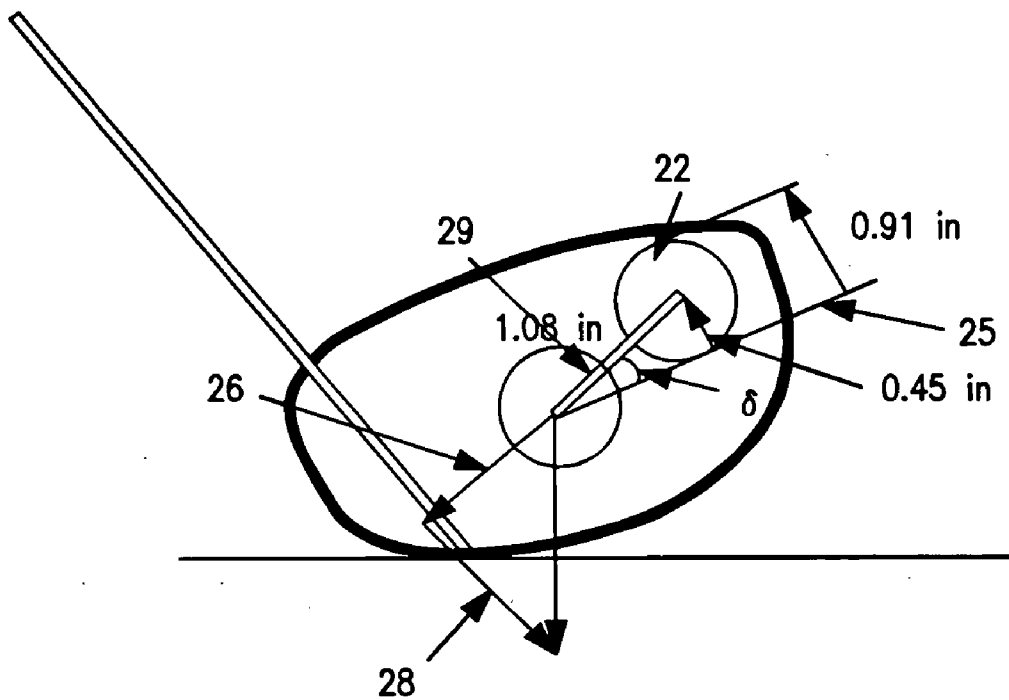
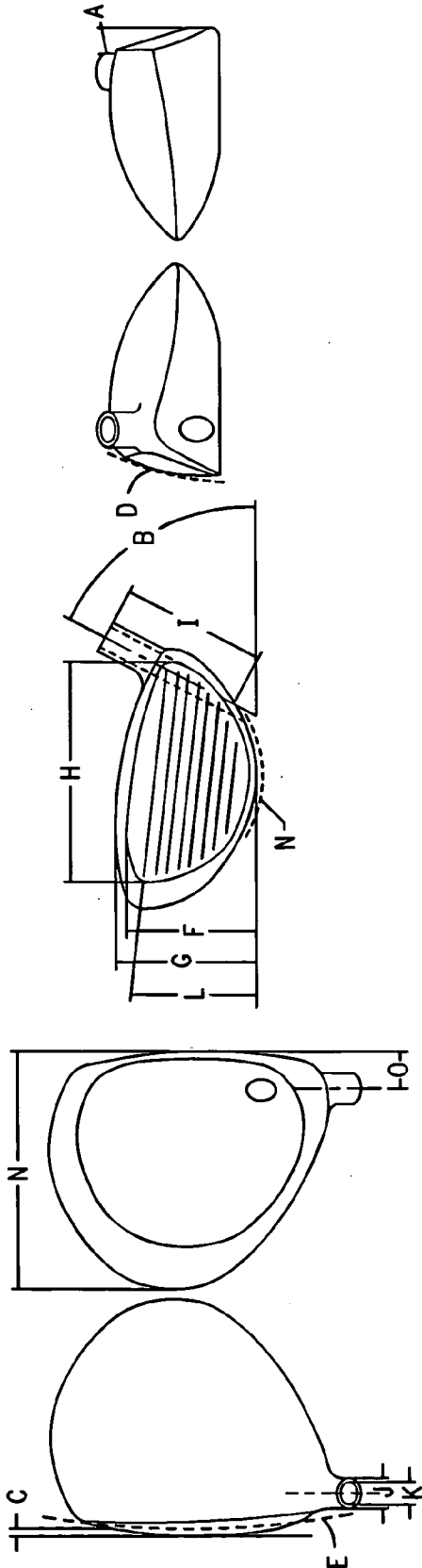

FIG. 9



CLUB NUMBER	FINISH WEIGHT GRAMS	A	B	C	D	E	F	G	H	I	J	K	L	M	N	O
9°	200	9°	61°	+1° OPEN	12°	18°	1.73°	TBDBC	3.400	TBDBC	.475	.339	s.040	2°	TBDBC	TBDBC
TOL →	s3q	s1°	s1°									s.002				

FIG. 10

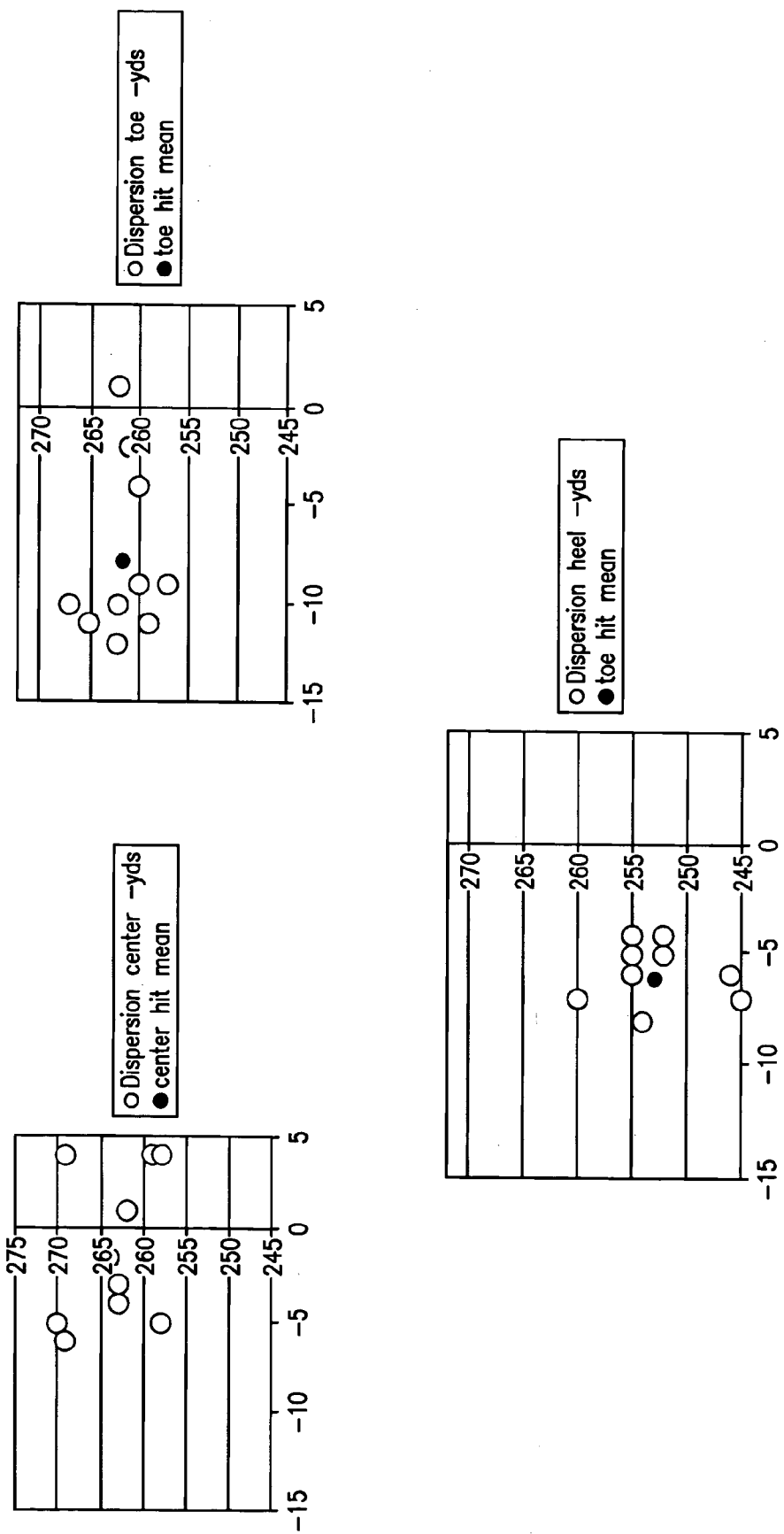

FIG. 11

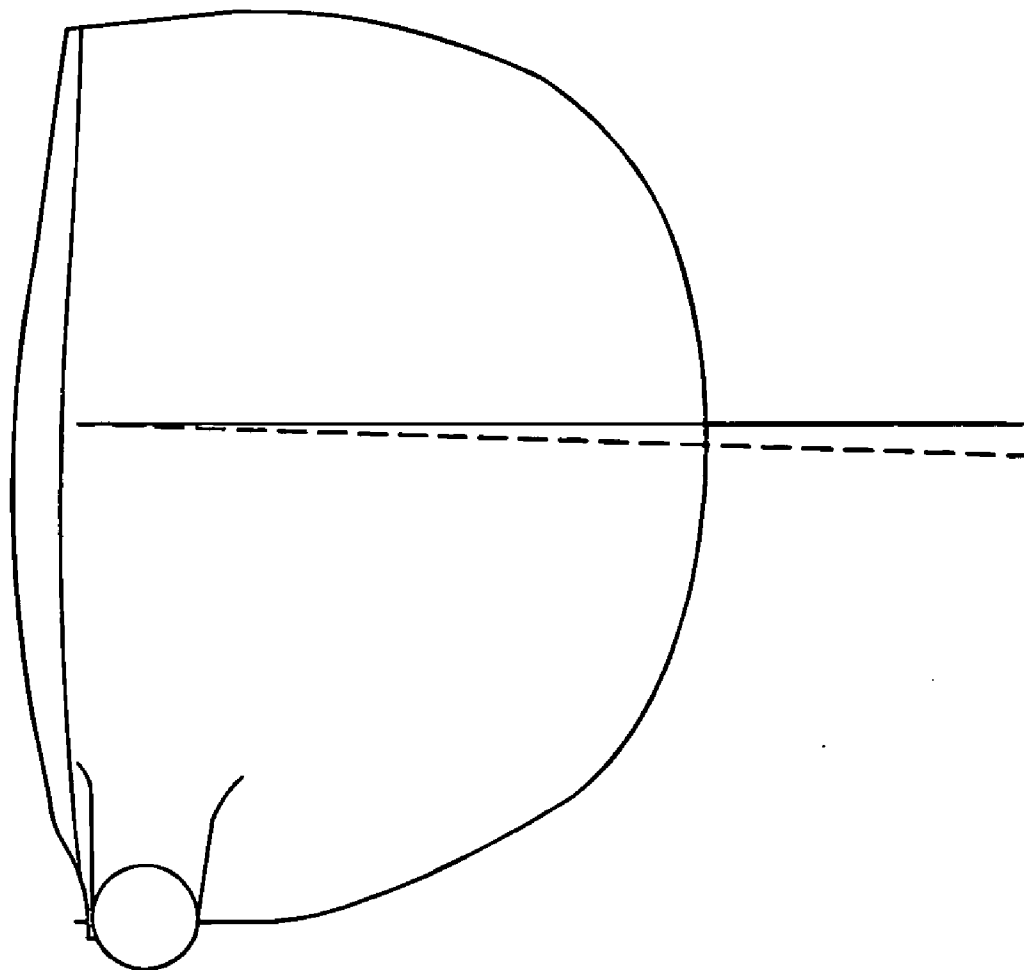

FIG. 12

IMPACT POINT DEVELOPMENT FOR GOLF CLUBS

[0001] This Application is a Continuation of U.S. patent application Ser. No. 10/162,959, filed Jun. 5, 2002, entitled: IMPACT POINT DEVELOPMENT FOR GOLF CLUBS.

[0002] This Application and Parent application Ser. No. 10/162,959 claim the benefit of U.S. Provisional Patent Application No. 60/295,882 filed Jun. 5, 2001, and incorporate the Provisional Patent Application herein by reference.

FIELD OF THE INVENTION

BACKGROUND OF THE INVENTION

[0003] Various prior art patents have addressed the problem of so-called off center hits where the club engages the ball at a point spaced from the center of gravity toward the toe or the heel. Patents include those listed below.

[0004] Antonious U.S. Pat. No.: 5,046,733, shows an iron wherein additional weight distributions positioned in the cavity in the back face of the iron when properly placed improve the accuracy and performance of the irons for a range of golfers. Antonious, however, does not disclose the application of his concept to wood club heads and does not extrapolate his theories to wood clubs. Antonious does not disclose or suggest essentially enlarging the sweet spot for a wood club wherein the lie angle is configured to maintain the impact point of the golf ball on the club face when the impact point is off the center of mass and wherein the mass of the club is concentrated in a predetermined area to provide an elliptical zone on the face of the club having a major axis generally perpendicular to the shaft setup angle so that hits in the elliptical zone produce generally the same distance as hits at the center of impact.

[0005] Scheie, et al., U.S. Pat. No.: 5,120,062 shows irons having a cavity in the back face which distributes the weight high in the toe and low in the heel. This is intended to produce an enhanced moment of inertia about an axis having about a 45 degree inclination to the hosel axis of the ironhead. Scheie based this angle on the findings of Masghati, et al., Patent No.: 4,471,961 which showed that for off-axis hits, the head rotated about an axis of about 45 degrees to the hosel axis. Therefore, Scheie does not disclose the configuration for a wood which is the subject of the present invention.

REFERENCED PATENTS

- [0006] MASGHATI. et al.
- [0007] TITLE: GOLF CLUB WITH BULGE RADIUS AND INCREASED MOMENT OF INERTIA ABOUT AS INCLINED AXIS
- [0008] U.S. PAT. NO.: 4,471,961
- [0009] DATE OF PATENT: SEP. 18, 1984
- [0010] ANTONIOUS
- [0011] TITLE: IRON TYPE GOLF CLUB HEAD WITH IMPROVED PERIMETER WEIGHT CONFIGURATION
- [0012] U.S. PAT. NO.: 5,046,733
- [0013] DATE OF PATENT: SEP. 10, 1991

- [0014] SCHEIE. et al.
- [0015] TITLE: GOLF CLUB HEAD WITH HIGH TOE AND LOW HEEL WEIGHTING
- [0016] U.S. PAT. NO.: 5,120,062
- [0017] DATE OF PATENT: JUN. 9, 1992

BRIEF DESCRIPTION OF THE DRAWINGS

- [0018] These and other objects of the present invention and the various features of details of the operation and construction thereof are hereinafter more fully set forth with the accompanying drawings wherein:
- [0019] FIG. 1 shows the face of a driver having a hit pattern forming an ellipse;
- [0020] FIG. 2 is a schematic view of a driver head showing the lie angle definition;
- [0021] FIG. 3 is another view showing the set up angle;
- [0022] FIG. 4 is a chart showing the driver set up angle as a function of butt height and shaft length;
- [0023] FIG. 5 is a chart comparing standard lie angles to set up angles for irons;
- [0024] FIG. 6 is a photograph showing a typical set up;
- [0025] FIG. 7 shows the forces on the club head due to gravity;
- [0026] FIG. 8 is a schematic showing enhanced performance of the driver with improved lie angle design;
- [0027] FIGS. 9 and 10 show offset hits on two lie angle driver designs;
- [0028] FIG. 11 is a drawing showing a head design in accordance with the present invention;
- [0029] FIG. 12 are charts showing results for tests conducted with a driver designed in accordance with the present invention; and
- [0030] FIG. 13 is a top view of the driver and the definition of the bulge radii.

DESCRIPTION OF RELATED ART

- [0031] Advances in technology and materials in golf club head design and especially in shaft design have made possible the fabrication of longer, lighter clubs particularly in the woods. These advances are claimed to hit the ball farther and to be easier to use because of their longer length and lighter shaft weight. However, in general, the lengthening of the club shaft have made it increasingly difficult to hit the ball consistently in the center of the club face resulting in decreased performance achievable with these new club characteristics.
- [0032] Data published in the Golfsmith Technical Journal in February 1998 on the variation of the impact point of the ball on the clubface 10 as a function of shaft length shows a consistent and predictable pattern 12 as shown in FIG. 1. This pattern is also observed in the wear pattern on the faces of drivers and irons used by the golfing public. This pattern can be bounded by an ellipse 20 having a major axis 29 approximately two inches in length and a minor axis (not shown) of about 1.1 inches in length with the major axis 29

perpendicular to the golfer's swing plane and the shaft axis **23**. The impact point pattern **12** found on a driver with a 45 inch shaft length is shown in **FIG. 1** and illustrates the extent of the miss area. The major axis **29** centerline of the impact ellipse **20** is generally perpendicular to the axis **23** of the shaft at impact and is about 45 degrees to the horizontal plane **24**.

[0033] These data show that with a standard lie angle for woods of 55 to 56 degrees, with a driver shaft of 45 inches, the centerline of the impact ellipse **20** moves up and off the club face, leading to fat, skied shots.

[0034] As shown in **FIG. 2**, the lie angle α is defined as the angle subtended by a line down the axis of the shaft **23**, and a line **24** in the horizontal plane tangent to the sole of the club at the contact point **25** that rests on the ground at address. This contact point **25** on the sole is located where a vertical line through the center of gravity (CG) of the club head intersects the sole. Thus the lie angle α is a fundamental design parameter of the club and is established by the initial design of the head shape, weight distribution, and location of the CG.

[0035] The standard lie angle for a driver observed by most manufacturers is 54 to 56 degrees. However, it has been found by analysis that this lie angle α range combined with standard length woods does not fit the general population. This has been found by an analysis of the setup angle β , for a spectrum of golfers. The lie angle α is a fundamental club design parameter wherein the setup angle β , as shown in **FIG. 3**, is determined by the golfer and is defined as the angle between the club shaft **23** and horizontal ground plane **24** when the golfer sets the club up to the ball. The setup angle β is determined by the shaft length and the hand height of the golfer at address, which then determines the butt height at the top of the club shaft. For the majority of the population, the butt height of the club is in the range of 30 to 33 inches. For shorter players and women, the butt height can be as low as 28 or 29 inches. Analyses has shown that the actual setup angle β for driver lengths of 43 to 46 inches is from 46 to about 42 degrees, as shown in the **FIG. 4** diagram.

[0036] This is compared to the driver lie angles α provided by the manufacturers, which range from 54 to 56 degrees. This large difference between lie angle α and setup angle β is only found in the woods. These angles are closely matched in iron designs as shown in the **FIG. 5** diagram.

[0037] In the case of the irons, the small difference between the lie angle α and the setup angle β is often compensated for by bending the hosel of the longer irons to match the golfer's setup angle β . The reason for this difference can be deduced from performance; the longer woods are more difficult to swing, and require a higher lie angle α to keep the impact point **20** of the ball on the clubface. This led the designers to adopt the 54 to 56 degree lie angle approach many years ago when the standard driver length was 43 inches. This effect will be analyzed further below.

[0038] The **FIG. 6** photo demonstrates the optimum setup parameters for the hands and the club position. This is demonstrated by a picture taken in the GE Laboratory in 1932, and is still viable today. Jim Reynolds personifies the modern ideal setup and hand position to the ball even though this photo was taken 70 years ago. His arms are vertical and

his hands are low and setup to the ball with a 45 degree shaft angle, shown by the dotted red lines.

[0039] His right hand is aligned along the shaft so that he transfers power to the ball along the line to the target, and his left hand is firm and angled up so that he overcomes the effect of gravity, and keeps the club aligned to the ball.

[0040] Reynolds head speed was clocked at 125 miles per hour, comparable to Tiger Woods and other current long driving professionals. He was using a 43 inch driver, which was standard at the time. The longer drivers used by modern professionals will lead to even lower setup angles β than used by Reynolds. The effect of these lower setup angles β will be analyzed below.

[0041] Descriptions of the behavior of the club during downswing of a number of professional golfers have been examined, and the following conclusions have been reached. As the club head is accelerated through the ball, there is a very large increase in the head speed in a very small time increment, as the hands release into the ball. This horizontal action and the forces associated with it have been the focus of many training and swing analyses. However, there is another force, which tends to be overlooked, and that is the vertical force of gravity on the club head, which operates continuously on the head pulling it down toward the ground.

[0042] An analysis of Charles Howell was done to show the relative timing of the segments of his downswing. These can be correlated with the shaft deflection curves for other pros to derive the predictions of the forces on the hands of the golfer during the golf swing. At the time of the release of the hands through the ball, Howell is $\frac{2}{3}$ of the way down from the start of the downswing to impact. The majority of the acceleration through the downswing occurs during the last third of the downswing where the club shaft moves from a horizontal position to the vertical position it has at impact. The time for this increment of the downswing is about 0.15 to 0.2 seconds for professional golfers. During this period there is a torque on the hands of about 15 ft-lbs associated with the horizontal acceleration of the club head into the ball and a lesser but significant torque in the vertical plane due to the inexorable pull of gravity on the club head equal to about 1 ft-lb. This resolves into about 0.7 ft-lbs normal to the shaft and 0.7 ft-lbs along the shaft axis. If this effect is uncompensated, the club head would drop about 7 or 8 inches during this short time. Even if the gravity pull is 90% compensated by the golfer, the club head would drop about 0.8 inches, with 70% of this motion normal to the shaft axis. So the impact point **22** would move diagonally up and toward the toe about 0.6 inches if the gravity force is not compensated. It is noted that the increase in torque (closely correlated with swing weight) on the golfers hands is about 7% for an increase of 3 inches in the shaft length of the driver from the standard 43 inches to 46 inches. If this is uncompensated by the golfer, as discussed above, this will result in the motion of the impact point on the face up and toward the toe, as shown in **FIG. 7** diagram.

[0043] The gravity force component **26** normal to the shaft, if uncompensated will cause the head to move downward and inward toward the golfer, which causes the ball impact point **22** to move from the center of the face to a point diagonally upward towards the toe of the club **27**. The other gravity component **28**, which is parallel to the shaft axis, adds to the pull on the hands caused by the horizontal

acceleration of the head **10** and is controlled by a firm grip on the club. The movement of the impact point **22** on the face of a driver with a standard 55 degrees lie angle α is shown in **FIG. 5**. Note that this correlates with the impact data shown in the Golfsmith data in **FIG. 1**.

SUMMARY OF THE INVENTION

[0044] The present invention defines a set of fundamental golf club design parameters that in conjunction with golfer's preferred setup position and angles result in maintaining the ball impact point on the golf club head. The improvement in performance for a driver with an enhanced design lie angle α of about 62 degrees is shown in **FIG. 8**. The enhanced performance of the club is obtained by optimizing the lie angle α which in concert with the setup angle β controls the position of the club head at address. The setup angle β established by the average golfer tilts up the toe of the club head and keeps the impact point **22** on the face, significantly enhancing the performance for a given off center hit. The off center impact point hit position will vary with the golfer's skill level and from hit to hit, but will generally follow the centerline **29** in **FIGS. 7 and 8**. **FIG. 8** shows the improvement in impact point with the enhanced performance club design parameters described in this disclosure.

DESCRIPTION OF THE PREFERRED EMBODIMENTS

[0045] Referring again to **FIG. 1**, the miss ellipse **20** from the test data is approximated by an ellipse **20** with a major axis **29** of 2 inches and a minor axis (not shown) dimension of about 1.1 inches. The ball impact circle diameter caused by the compression of the ball at impact has been estimated from 0.7 inches to as much as 0.92 inches for the longer hitters now playing the game. Using the larger ball impact diameter measurement, it can be seen from **FIG. 1** that the miss ellipse impact area **22** is formed by the overlay of multiple ball impact areas, showing that the centerline **29** of the center of these ball impact areas **22** is close to a line perpendicular to the shaft centerline **23**. For the larger ball impact circle diameter of 0.92 inches, the length of this perpendicular line is 1.08 inches, i.e. 2-0.92 inches.

[0046] In **FIG. 9**, the path of the locus of hit impact points **29** is perpendicular to this setup angle axis as seen in the test data. Thus, for an average golfer, with a setup angle β of 45 degrees, with a standard 55 degree lie angle α , the hit impact point path **29** is tilted up and forms an angle δ at 35 degrees to the horizontal axis **25** of the face. Using trigonometry, it can be seen that the top of the hit impact point **22** at the toe would be 1.08 inches, or more than 27 mm above the centerline of the face. Even on a 50 mm high titanium driver face, this would put the top of the miss impact point **22** off the top of the face.

[0047] Alternatively, a driver design configuration of the present invention shown in **FIG. 10** with a lie angle α of 62 degrees and a setup angle of 45 degrees, the face centerline **25** will be aligned within 27 degrees of the miss ellipse centerline **29**, keeping the impact point **22** on the club face.

What is claimed is:

1. A golf club comprising an elongated shaft, a club head at one end of the shaft having a face, a heel portion, a toe portion and a sole portion;

a lie angle configured to maintain the impact point of a golf ball on the club face when the impact point is offset from the center of mass, said lie angle being the angle

subtended by the axis of the shaft and a horizontal plane tangent to the sole of the club at the point where a vertical line through the club head center of gravity intersects said club head sole.

2. A driver or metal wood golf club having a club head with a heel portion and a toe portion at one terminal end of a shaft wherein said shaft centerline and a plane parallel to the ground and tangent to said club head sole form a lie angle when said club head is at rest and positioned to strike said golf ball;

the mass distribution said club head being concentrated at said toe and heel;

a club face on said club head operable for striking a golf ball and spanning the area between said heel and said toe of said club head and having a heel to toe bulge defined by a radius, NR, whose center is square to the face or offset towards said heel, radius OR, and whose arc is swept from heel to toe of said club face as described in **FIG. 13**;

a lie angle configured to maintain the impact point of said golf ball on said club face when said impact point is off the center of mass, said lie angle which is the angle between the centerline of the shaft and a horizontal plane tangent to the sole of the club being greater than about 60°.

3. A driver golf club having a club head with a heel portion and a toe portion at one terminal end of a shaft wherein said shaft centerline and a plane parallel to the ground and tangent to said club head sole form a lie angle when said club head is at rest and positioned to strike said golf ball;

the mass distribution of said club head being concentrated at said toe and heel;

a club face on said club head operable for striking a golf ball and spanning the area between said heel and said toe of said club head and having a heel to toe bulge defined by a radius, NR, whose center is square to the face or offset towards said heel, radius OR, and whose arc is swept from heel to toe of said club face as described in **FIG. 2**;

a lie angle configured to maintain the impact point of said golf ball on said club face when said impact point is off the center of mass said lie angle which is the angle between the centerline of the shaft and a horizontal plane tangent to the sole of the club being greater than about 60° and wherein the height of the clubface as measured from the top edge to the sole edge at its greatest point is greater than 47 mm (1.85 inches).

4. A driver golf club having a club head with a heel portion and a toe portion at one terminal end of a shaft wherein said shaft centerline and a plane parallel to the ground and tangent to said club head sole form a lie angle when said club head is at rest and positioned to strike said golf ball;

the mass distribution of said club head being concentrated at said toe and heel;

a club face on said club head operable for striking a golf ball and spanning the area between said heel and said toe of said club head and having a heel to toe and sole to the top of club head bulge defined by a radius whose

center is offset toward said heel and whose arc is swept from said heel to said toe of said club face;

a lie angle configured to maintain the impact point of said golf ball on said club face when said impact point is off the center of mass said lie angle which is the angle between the centerline of the shaft and a horizontal plane tangent to the sole of the club being greater than about 60°, the mass of the club head being concentrated in predetermined area and combined with said preferred lie angle provides an elliptical zone on the face of the club whose major axis is generally perpendicular to the shaft and wherein hits in the zone produce generally the same distance as hits at the center of impact.

5. A golf club metal wood or utility wood comprising a shaft having a gripping section at one end and a club head having a heel portion, and a toe portion attached to the shaft at the other end, the shaft centerline of said shaft and a horizontal plane parallel to the ground and tangent to said club head forming a lie angle when said club head is at rest, said horizontal plane being tangent to the said club head sole at a predetermined point where a vertical line through the club head center of gravity intersects the sole;

the mass distribution of said club head concentrated in the toe and the heel and the periphery of the head;

a club face on said club head operable for striking a golf ball and spanning the area between the said heel and said toe of said club head and having a heel to toe bulge defined by a radius whose center is square to the face or offset towards said heel, and whose arc is swept from heel to toe of said club face; and

a lie angle configured to maintain the impact point of said golf ball on said club face when said impact point is off the face center and located in the impact ellipse represented.

6. A golf club as claimed in claim 5 said lie angle is greater than 60 degrees.

7. A golf club as claimed in claim 6 wherein the length of the shaft measured from the heel end of the sole to the butt end is between about 39" and 48".

8. A golf club as claimed in claim 6 wherein the height of the clubface as measured from the top edge to the sole edge at its greatest point is greater than 47 mm (1.85 inches).

9. A golf club as claimed in claim 6 wherein a line, T1, in FIG. 2, tangent to the top edge of the clubface is tilted upwardly towards the toe at an angle greater than 2 degrees to the horizontal.

10. A golf club as claimed in claim 5 wherein the mass distribution of the club head is concentrated in predetermined areas and combined with said preferred lie angle provides an elliptical zone on the face of the club, whose major axis is generally perpendicular to the shaft setup angle and wherein hits in the elliptical zone produce generally the same performance as hits at the center of impact on the face, the shaft setup angle 3 being the angle the club shaft makes to the horizontal as the golfer addresses the ball, and is determined by the length of the club shaft and the vertical height of the butt of the shaft as determined by the hand height of the golfer at setup.

11. A golf club as claimed in claim 5 wherein the mass concentration is higher in the toe and lower in the heel to maximize the moment of inertia about an axis extending parallel to the setup angle plane and passing through the center of gravity of the club head.

12. A golf club as claimed in claim 5 with a clubface designed with a thickness distribution so as to optimize the hit performance in the said elliptical hit zone.

* * * * *