

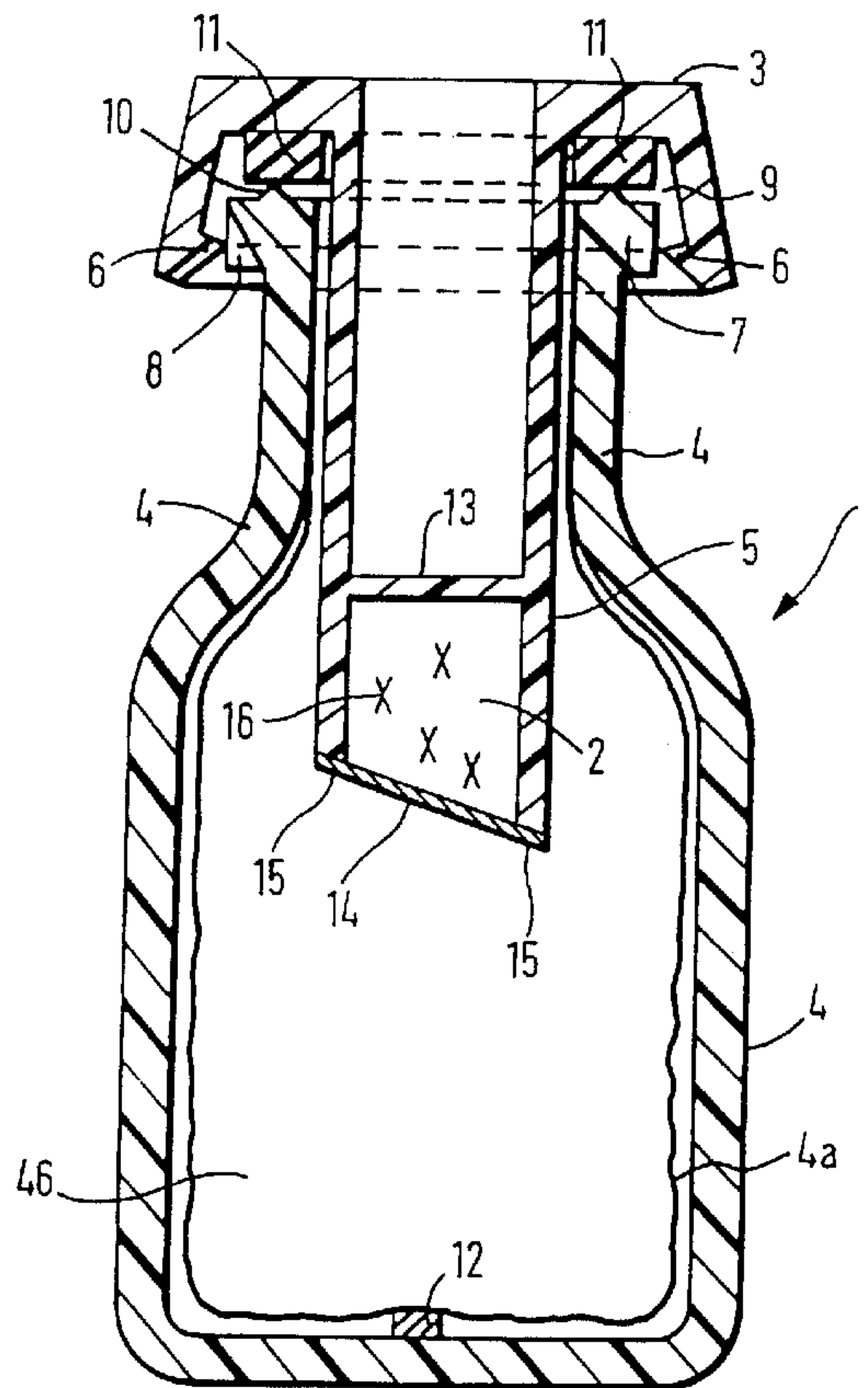

(86) Date de dépôt PCT/PCT Filing Date: 1997/04/18
 (87) Date publication PCT/PCT Publication Date: 1997/10/30
 (45) Date de délivrance/Issue Date: 2006/01/10
 (85) Entrée phase nationale/National Entry: 1998/10/15
 (86) N° demande PCT/PCT Application No.: EP 1997/001958
 (87) N° publication PCT/PCT Publication No.: 1997/039831
 (30) Priorité/Priority: 1996/04/19 (196 15 422.7) DE

(51) Cl.Int.⁷/Int.Cl.⁷ A61M 15/00, A61K 9/72, A61K 9/20,
A61K 9/12, B65D 83/40
 (72) Inventeur/Inventor:
HOCHRAINER, DIETER, DE
 (73) Propriétaire/Owner:
BOEHRINGER INGELHEIM PHARMA GMBH & CO. KG,
DE
 (74) Agent: FETHERSTONHAUGH & CO.

(54) Titre : CARTOUCHE A DEUX CHAMBRES POUR DISTRIBUER DES AEROSOLS DE FACON DOSEE SANS GAZ PROPULSEUR
 (54) Title: TWO-CHAMBER CARTRIDGE FOR PROPELLANT-FREE METERED AEROSOLS



(57) Abrégé/Abstract:

The invention relates to a two-chamber cartridge for drug formulations for propellant-free inhalers.

Abstract

5 The invention relates to a two-chamber cartridge for
drug formulations for propellant-free inhalers.

27400-187

-1-

**Two-chamber cartridge for propellant-free
metering aerosols**

The present invention relates to a two-chamber cartridge for liquids, particularly for drug formulations
5 for use in propellant-free metering aerosols.

International Patent Application WO91/14468 "Atomizing Device and Methods" describes a device for propellant-free administration of a metered quantity of a liquid pharmaceutical composition for use by inhalation. A
10 further developed embodiment is described, for example, in WO97/12687. For applications of this kind it is required to package the solutions containing the active substance into containers in such a way as to include only tiny residues of air and gas. Gas bubbles would lead to uncertainty in the
15 accurate metering of the active substance. Containers of this kind are disclosed for example in International Patent Application WO96/06011. The containers described therein are particularly suitable for those pharmaceutical compositions which can be stored for lengthy periods in the
20 form of an aqueous or ethanolic solution. For active substances which decompose in their solutions after only a few months there have not hitherto been any suitable containers which would allow commercial use of such sensitive preparations in propellant-free metering aerosols.

25 The invention provides a cartridge for propellant-free metering aerosols consisting of a container with a closure cap for holding liquids, an internal encircling bead formed on a lower edge of the closure cap which in a closed position engages below a ring running
30 around the outside of the container, and a connector connected to the closure cap, which displaces some of the

27400-187

-1a-

contents of the container as the closure cap is pushed onto a neck of the container, characterised in that the connector contains at least one chamber which is sealed off from the outside and from the interior of the container by two
5 pierceable partitions.

The invention also provides a closure cap for a container for propellant-free metering aerosols, having an internal encircling bead formed on a lower edge of the closure cap which in a closed position engages below a ring
10 running around an outside of the container, and a connector connected to the closure cap, which displaces some of the contents of the container as the closure cap is pushed onto a neck of the container, characterised in that the connector contains at least one chamber which is sealed off from the
15 outside and from the interior of the container by two pierceable partitions.

The invention now relates to a cartridge which has two chambers for separate storage of active substance and solvent. The cartridge is constructed so that, when the

- 2 -

cartridge is inserted in a device for producing the aerosol, the chamber containing the active substance is pierced by means of a cannula, with the result that the active substance comes into contact with the solvent and is dissolved. The storage time of the pharmaceutical preparation can be extended significantly by the separate storage of active substance and solvent. The active substance may be present in the chamber as a powder, granules or in the form of a tablet. Similarly, pharmacologically acceptable excipients may be present. Generally, those galenic formulations which ensure ease of solution of the active substance in the solvent are preferred. In the case of tablets, excipients which bring about better dissolution of the tablet may be added. Similarly excipients may be added which increase the stability of the active substances. In many cases, the active substance may also be present in the chamber in dissolved form if the active substance is stable in the solvent and the solvent is miscible with the solvent in the other chamber, hereinafter also referred to as container.

The invention is hereinafter explained in more detail with reference to some specific embodiments by way of example.

Figure 1 shows an axial section along the longitudinal axis of the cartridge (1) in accordance with the invention with the chamber (2) for receiving the active substance, the chamber (2) being an integral part of the closure cap (3).

Figure 2 shows another embodiment of the closure cap (3) with chamber (2) when the cartridge is in its closed state, the container (4) being merely indicated.

Figures 3a to 3c show further embodiments of the closure

- 3 -

cap (3) in accordance with the invention with chamber (2).

5 Figure 4 shows a section along the longitudinal axis of an embodiment of the closure cap in accordance with the invention, in which the chamber (2) contains a minitab^let (16a) as its supply of active substance.

10 Figure 1 shows the cartridge (1) in accordance with the invention consisting of a container (4) and a closure cap (3). The closure cap has a device (5) - in this case in the form of an immersed connector - through which some of the contents of the container (4) are displaced during the closure process and the container
15 is filled with virtually no air bubbles. An internal encircling bead (6) on the lower edge of the closure cap (3) engages underneath a cylindrical ring (7) running around the outside of the neck of the container in the closed position. In the closed position the gap between
20 the flat part of the closure cap (3) and the upper edge of the neck of the container, which may optionally have an encircling rib (10) to improve the seal, is filled by a sealing ring (11) and in this way the interior of the container (3) is sealed off. The internal diameter of
25 the sealing ring (11) is appropriately such that it fits tightly against the connector (5). The vent opening or opening(s) (8) may also be located at other points on the outside of the cap, e.g. on the side in the cylindrical part of the cap.

30

In another embodiment (Fig. 2a) the closure cap (3) is closed off by a sleeve (20) made of aluminium which is crimped in position. The sleeve (20) is constructed so as to have a central opening (21) for the insertion of
35 the cannula (22). This opening may be closed off by a septum as a protection against dust and other contaminants. This closure technique is known, for

example, in injection ampoules.

In one particular embodiment the container (4) contains a collapsible internal container (4a) of flexible material. The internal container may, in a preferred embodiment, be fixed to the lower part of the container (4) by a device (12).

The chamber (2) is located in the lower part of the connector (5), the chamber being closed off to the outside by means of a partition, e.g. in the form of a septum (13), and to the interior of the container (4b) by means of a partition, e.g. in the form of a film (14). The septum (13) and film (14) are made from a material which can easily be pierced by a cannula having a pointed or rounded tip. The septum (13) is preferably made of a material which seals the interior (4b) off to the outside even when the cannula has pierced it.

Usually, the partitions consist of thin plastics or aluminium foil. In one embodiment the septum (13) may have frangible points where it is connected to the side wall of the connector (5), so that when the partition is pierced it tears open at the frangible points.

Preferably, the film (14) is in the form of a welded-on diffusion-tight sealing film which tears when pierced and allows the active substance to enter the interior (4b) of the container. The frangible points may also be provided in the region of the lower side wall of the connector (5) so that the lower part of the side wall of the connector is also torn away.

The position of the partition (13) may vary within wide areas of the interior of the connector (5), but it is preferably arranged in accordance with the quantity of active substance (16) so that the interior formed by the two partitions (13) and (14) contains, in addition to the powder, the least possible amount of gas (air).

- 5 -

Figure 2 also shows an axial section through the neck of a container with a closure cap (3) fitted thereon, the chamber (2) being of different configuration.

5 Figure 3a shows another embodiment of the closure cap according to the invention, in which the interior of the immersed connector is constructed so as to form a guide (17) for a cannula for drawing off liquid. In the present instance, the vent openings (8) are provided in
10 the upper part of the container (4). As already described, the vent openings may alternatively be provided on the closure cap. The chamber (2) for holding the active substance is arranged separately in the lower part of the connector (5). Instead of a
15 pierceable partition (14), frangible points (18) may be provided so that, as the partition (13) is pierced the chamber is torn away at the frangible points (18) by pressure on the partition (14). In this embodiment, the partition (14) may be constructed as the base of the
20 connector (5).

Figures 3b, 3c show other embodiments regarding the construction of the immersed connector (5) and the guide (17) for the cannula for withdrawing the liquid.

25

Figure 3b shows an embodiment in which the guide (17) merges into a press fit (19). The press fit is designed, in terms of diameter and length, so that on the one hand the resistance for pushing the cannula
30 through is kept to a minimum and, on the other hand, a sufficient seal is achieved between the connector and the cannula.

Fig. 3c shows an embodiment with an elastic O-ring seal (20) between the connector and the piercing cannula (not shown in the drawing). The device which prevents the O-ring from accidentally becoming detached is not shown.

35

- 6 -

As shown in Figs. 3b and 3c, the lower end of the immersed connector with the partition (14) may appropriately be chamfered, preferably by 20° to 60° relative to the axis of the connector. This makes it easier for the partition to be pierced with a "blunt" cannula the end face of which is perpendicular to the axis of the cannula. The advantages of a "blunt" as against a "sharp pointed" cannula are the small risk of injury to the user, the reduced machining work required to produce the end face of the cannula and the reduced risk of particle abrasion on the wall of the connector as the cannula is inserted.

As shown in Figure 4, which corresponds largely to Figure 3a, the chamber (2) contains the active substance in the form of a small tablet. Compared with a powdered active substance, the active substance in the form of the minitabulet according to the invention is substantially easier to introduce into the chamber (2), and also a tablet has advantages when the septum (13) is pierced by a cannula and subsequently the tablet (21) is pushed through the foil (14). On the one hand, this ensures that the relatively hard tablet does not block the cannula, and on the other hand it ensures that the full amount of active substance from the chamber enters the container (4). With the highly effective drugs commonly used in metering aerosols nowadays, a precisely metered solution of active substance is absolutely necessary for purposes of drug safety. Moreover, if the chamber (2) is filled with a tablet, the sealing surface is not contaminated with dust, as would be the case if it were filled with powder.

The tablet in accordance with the invention has a diameter of between 2 and 3 mm, preferably between 2.2 and 2.3 mm, and is between 1.8 and 3.5 mm long. The tablet in accordance with the invention has a

- 7 -

compressive strength of between 2 and 10 N/mm². The compressive strength is measured by clamping the tablet between flat surfaces and increasing the force until the tablet breaks up. The tablets were clamped in such a way as to come into contact with the flat surfaces along two generatrices (not with the top and bottom surfaces). The compressive strength is the force divided by the cross-sectional area (diameter times length of the cylindrical tablet).

10

The tablets in accordance with the invention consist of the active substance and conventional tableting excipients. Preferred active substances are those which can be used in low doses, e.g. up to 100 micrograms of active substance per single dose. These include, for example, atrovent, anticholinergics, β -sympaticomimetics, e.g. formoterol. The preferred excipients are lactose (200 mesh), glucose (200 mesh) and shape separating agents.

20

The container in accordance with the invention has a solvent volume of 4 ml, so that 0.5% solutions of active substance can be produced with a minitabulet weighing 20 mg. The solvents are preferably water or ethanol or mixtures thereof. Other physiologically acceptable solvents are also suitable.

25

For removing liquid from the cartridge (1) in accordance with the invention, the partitions (13 and 14) are pierced with a cannula. Preferred embodiments are those wherein the container (4) has a readily deformable inner bag (4a) and the end of the cannula is located half way up the container when the liquid is drawn off. In this case, air bubbles have the least disruptive effect.

30

Preferably, the minitabulet (16a) in accordance with the invention is used as the supply of active substance.

35

- 8 -

The container and closure cap are generally made of plastics. Since the liquid packaged therein is virtually incompressible, the system of container and closure cap must be sufficiently deformable as the liquid expands in the warm. Similarly, when the liquid is drawn off, the walls of the container must yield or collapse sufficiently. The partition generally consists of a thin plastics film. Preferably, the partition (14) consists of a thin coated aluminium which is sealed.

10

Containers of this kind as well as the closure cap may be produced using the suitable plastics, e.g. polyethylene or preferably polypropylene, available to those skilled in the art.

15

The cartridge in accordance with the invention which is for drug formulations for an inhaler should have a long shelf life. For this reason it is necessary that the solvent cannot diffuse out of the interior (4a) of the container into the chamber (2) containing the active substance before use. In addition to having a sufficiently thick-walled chamber, an aluminium coating may also be applied to the outer or inner surfaces of the chamber (2). It should be emphasised that the insertion of the cartridge with the chamber (2) in the inhaler does not require any further manual strength on the part of the patient than the insertion of a conventional cartridge.

25

27400-187

-9-

CLAIMS:

1. A cartridge for propellant-free metering aerosols consisting of a container with a closure cap for holding liquids, an internal encircling bead formed on a lower edge
5 of the closure cap which in a closed position engages below a ring running around the outside of the container, and a connector connected to the closure cap, which displaces some of the contents of the container as the closure cap is pushed onto a neck of the container, characterised in that
10 the connector contains at least one chamber which is sealed off from the outside and from the interior of the container by two pierceable partitions.
2. The cartridge according to claim 1, characterised in that the at least one chamber contains a pharmaceutical
15 composition.
3. The cartridge according to claim 2, characterised in that the container contains a solvent.
4. The cartridge according to any one of claims 1 to 3, characterised in that the at least one chamber
20 contains an active substance which is suitable for administration by inhalation.
5. The cartridge according to claim 4, characterised in that the active substance is present in the form of a tablet.
- 25 6. The cartridge according to any one of claims 1 to 5, characterised in that the pierceable partition separating the at least one chamber from the outside is in the form of a septum and the pierceable partition separating the at least one chamber from the interior of the container
30 is in the form of a sealing film.

27400-187

-10-

7. The cartridge according to claim 6, characterised in that the at least one chamber has frangible points at its points of connection to the connector, so that when the septum is pierced by pressure on the at least one chamber
5 the at least one chamber tears at the frangible points.

8. The cartridge according to any one of claims 1 to 5, characterised in that the at least one chamber has frangible points at its points of connection to the connector, so that when the pierceable partition separating
10 the at least one chamber from the outside is pierced by pressure on the at least one chamber the at least one chamber tears at the frangible points.

9. A closure cap for a container for propellant-free metering aerosols, having an internal encircling bead formed
15 on a lower edge of the closure cap which in a closed position engages below a ring running around an outside of the container, and a connector connected to the closure cap, which displaces some of the contents of the container as the closure cap is pushed onto a neck of the container,
20 characterised in that the connector contains at least one chamber which is sealed off from the outside and from the interior of the container by two pierceable partitions.

10. The closure cap according to claim 9, characterised in that the at least one chamber contains an
25 active substance suitable for administration by inhalation.

11. The closure cap according to claim 10, characterised in that the active substance is present in the form of a tablet.

12. The closure cap according to any one of claims 9
30 to 11, characterised in that the pierceable partition

separating the chamber from the outside is in the form of a septum and the pierceable partition separating the at least one chamber from the interior of the container is in the form of a sealing film.

5 13. The closure cap according to claim 12,
characterised in that the at least one chamber has frangible
points at its points of connection to the connector, so that
when the septum is pierced by pressure on the at least one
chamber the at least one chamber tears at the frangible
10 points.

14. The closure cap according to any one of claims 9
to 11, characterised in that the at least one chamber has
frangible points at its points of connection to the
connector, so that when the pierceable partition separating
15 the at least one chamber from the outside is pierced by
pressure on the at least one chamber the at least one
chamber tears at the frangible points.

15. The closure cap according to claim 12 or 13,
characterised in that the septum is made from a resilient
20 material so that the interior of the container is sealed off
from the outside even after the container is pierced by a
cannula.

16. The closure cap according to any one of claims 9
to 11, characterised in that the pierceable partition
25 separating the at least one chamber from the outside is made
from a resilient material so that the interior of the
container is sealed off from the outside even after the
container is pierced by a cannula.

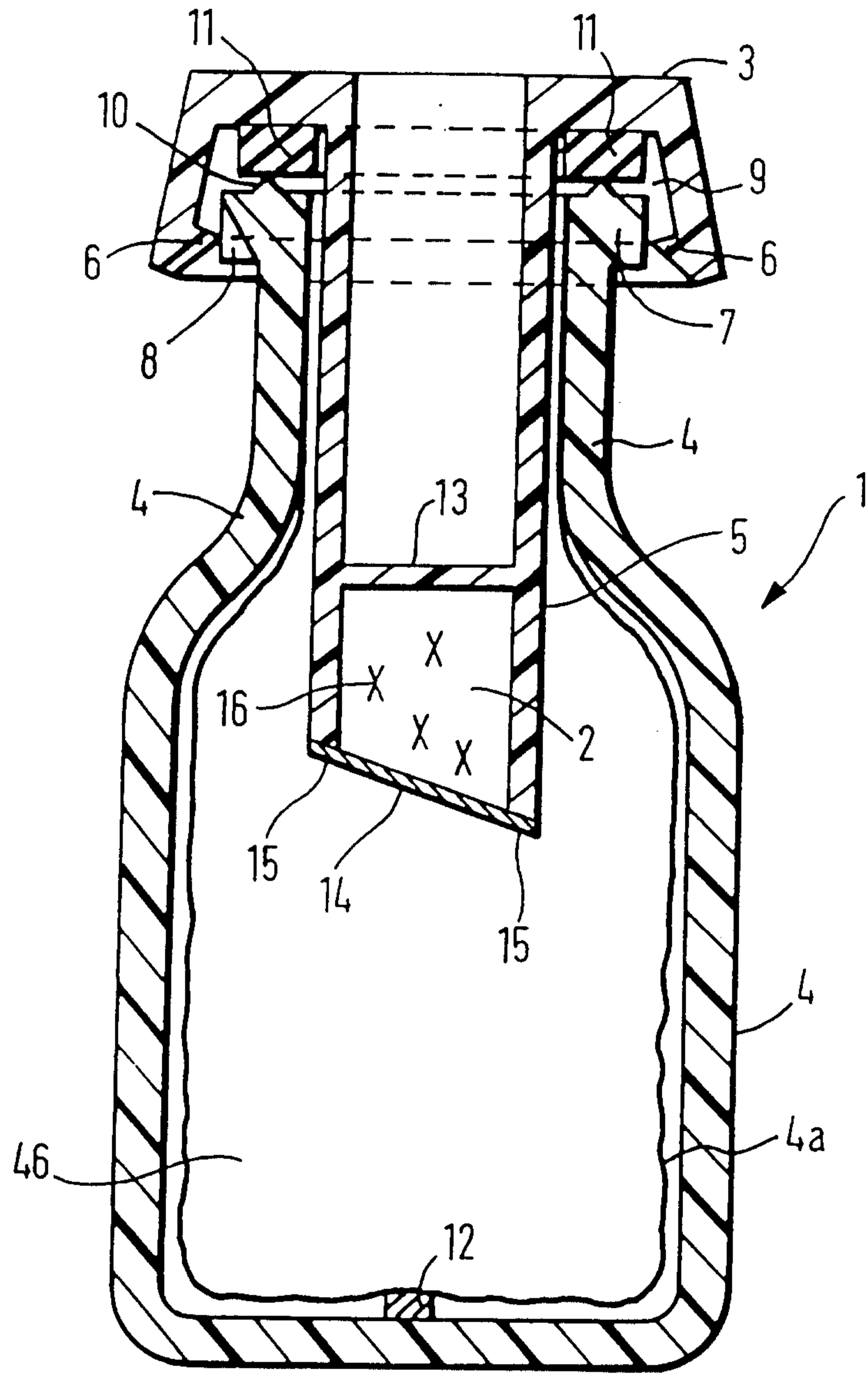

FIG. 1

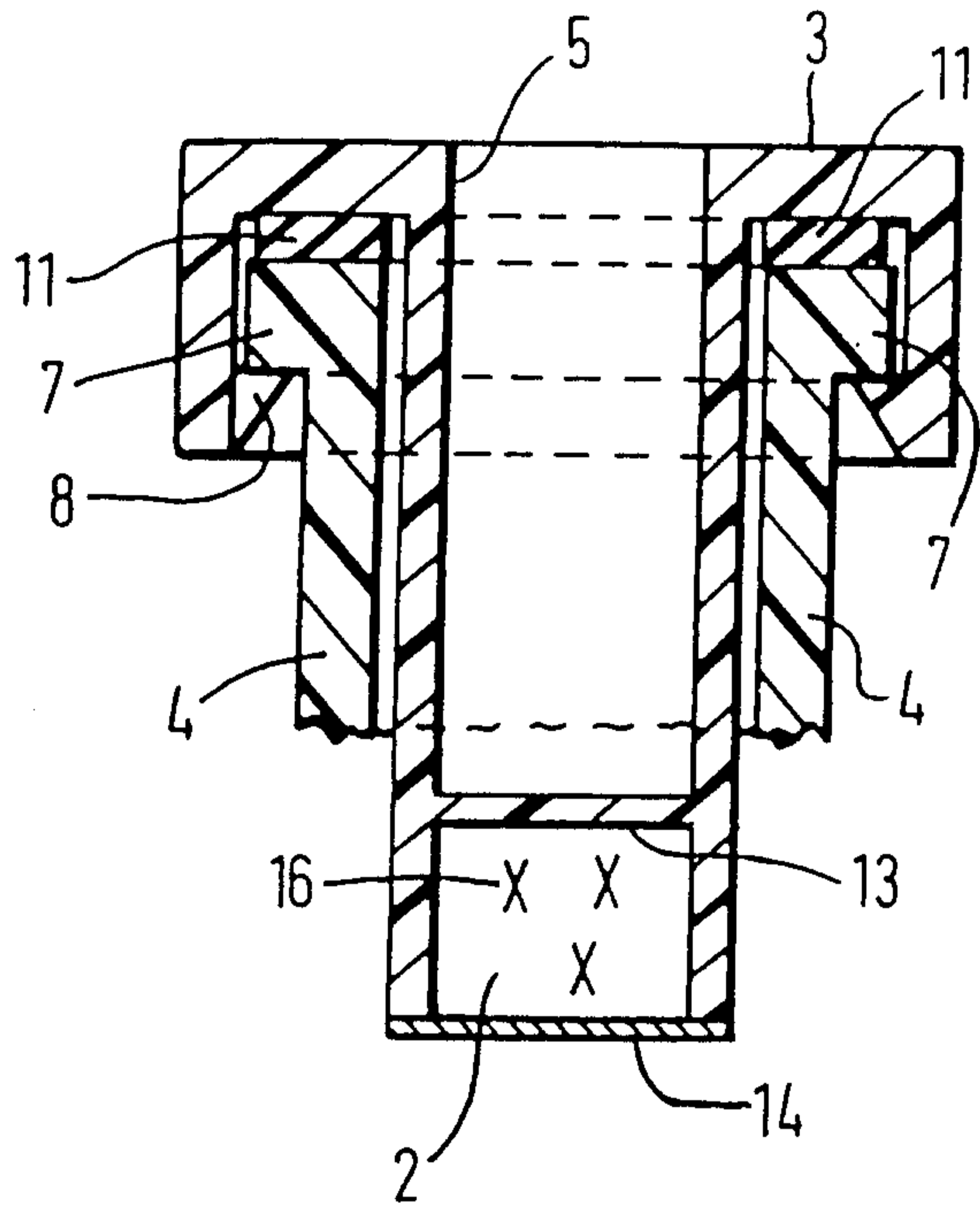

FIG. 2

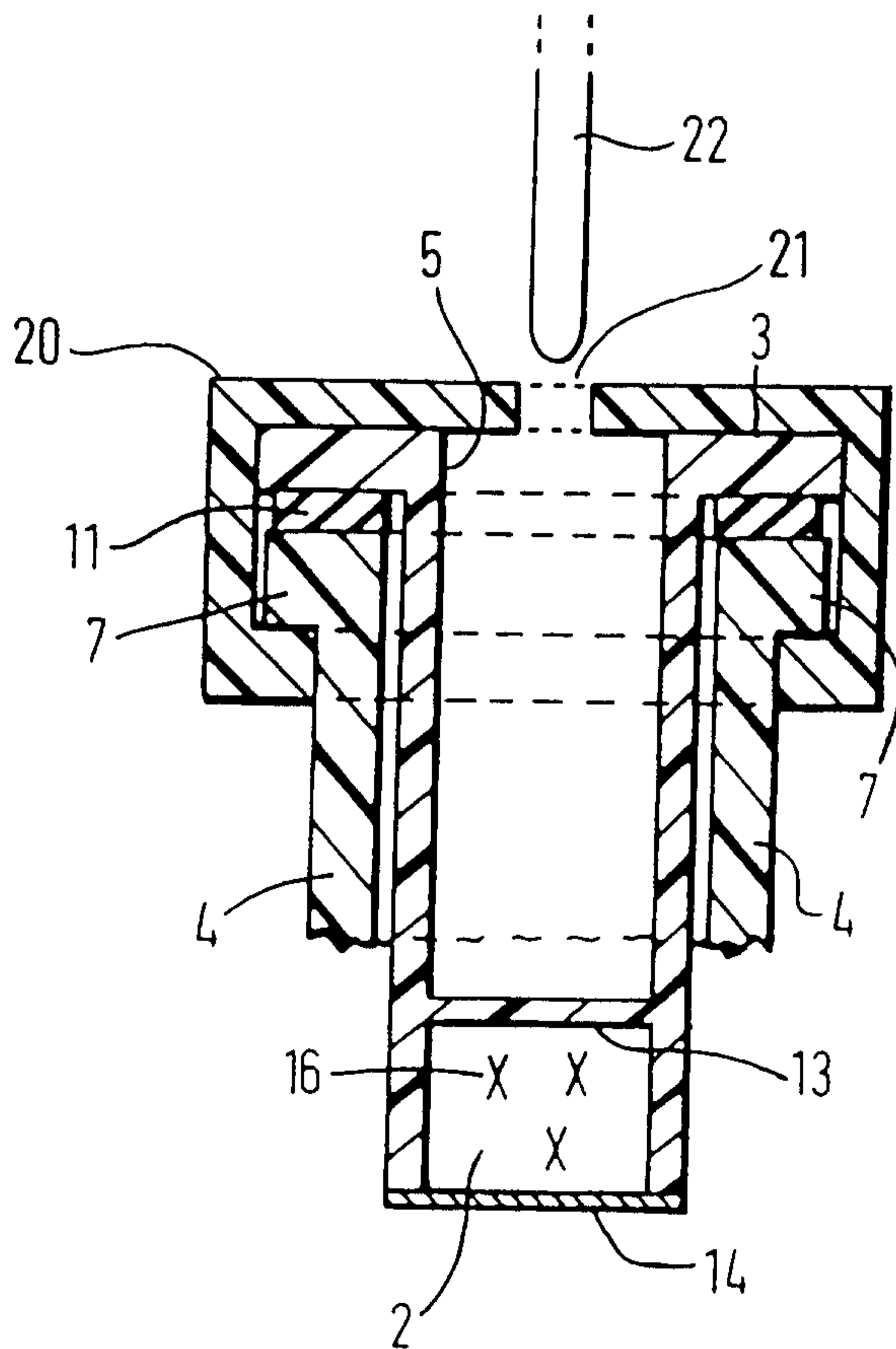

FIG. 2a

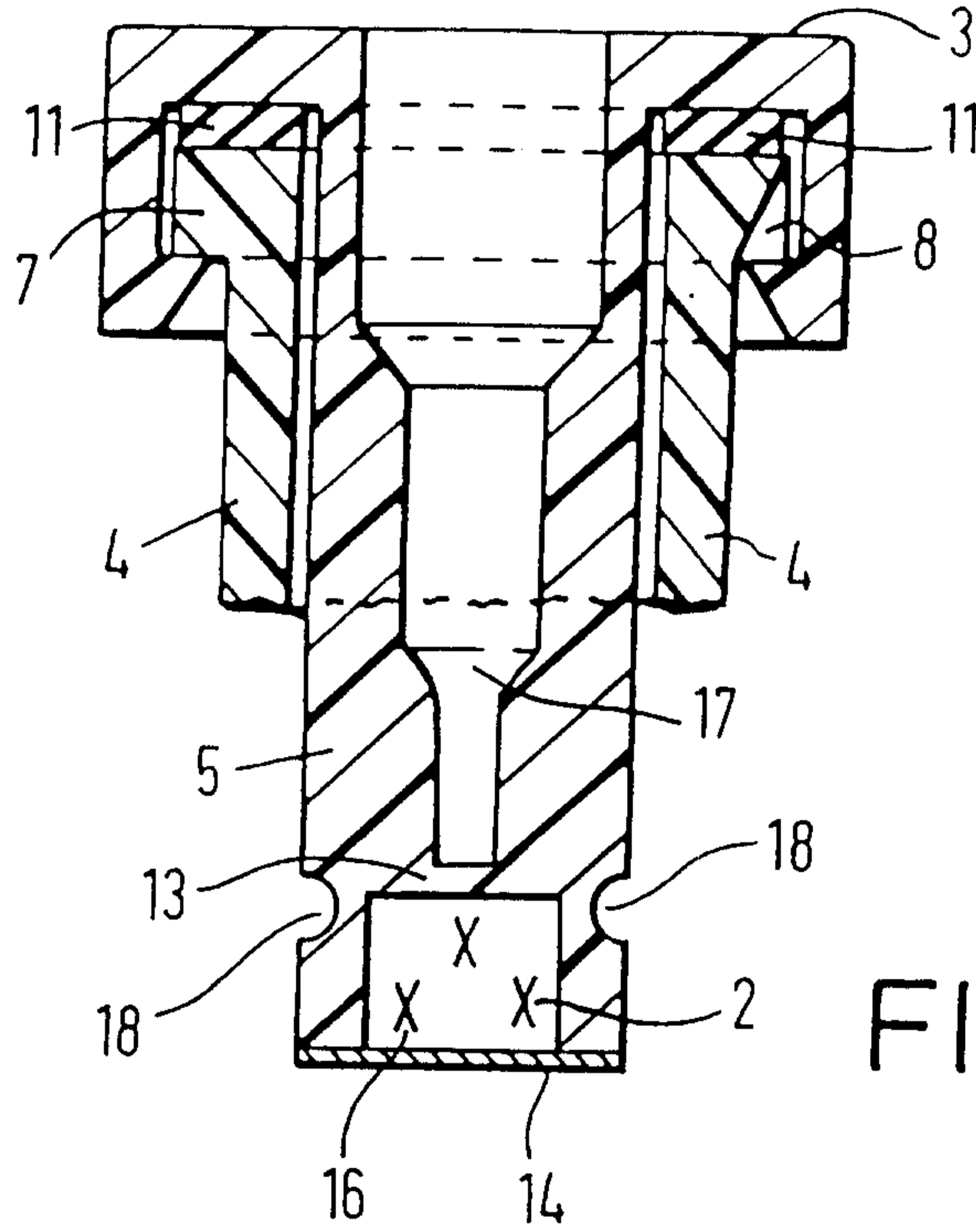

FIG. 3a

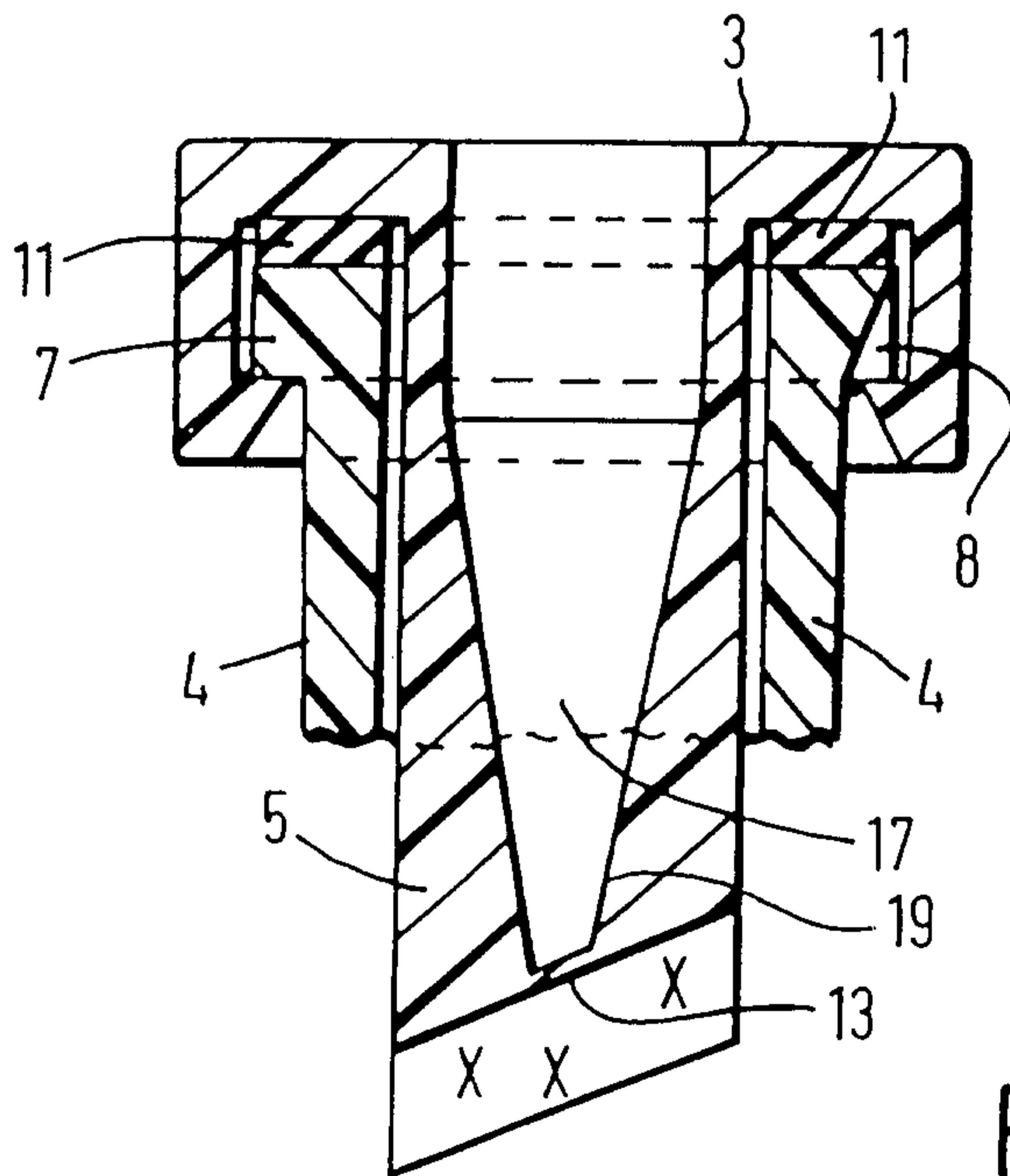

FIG. 3b

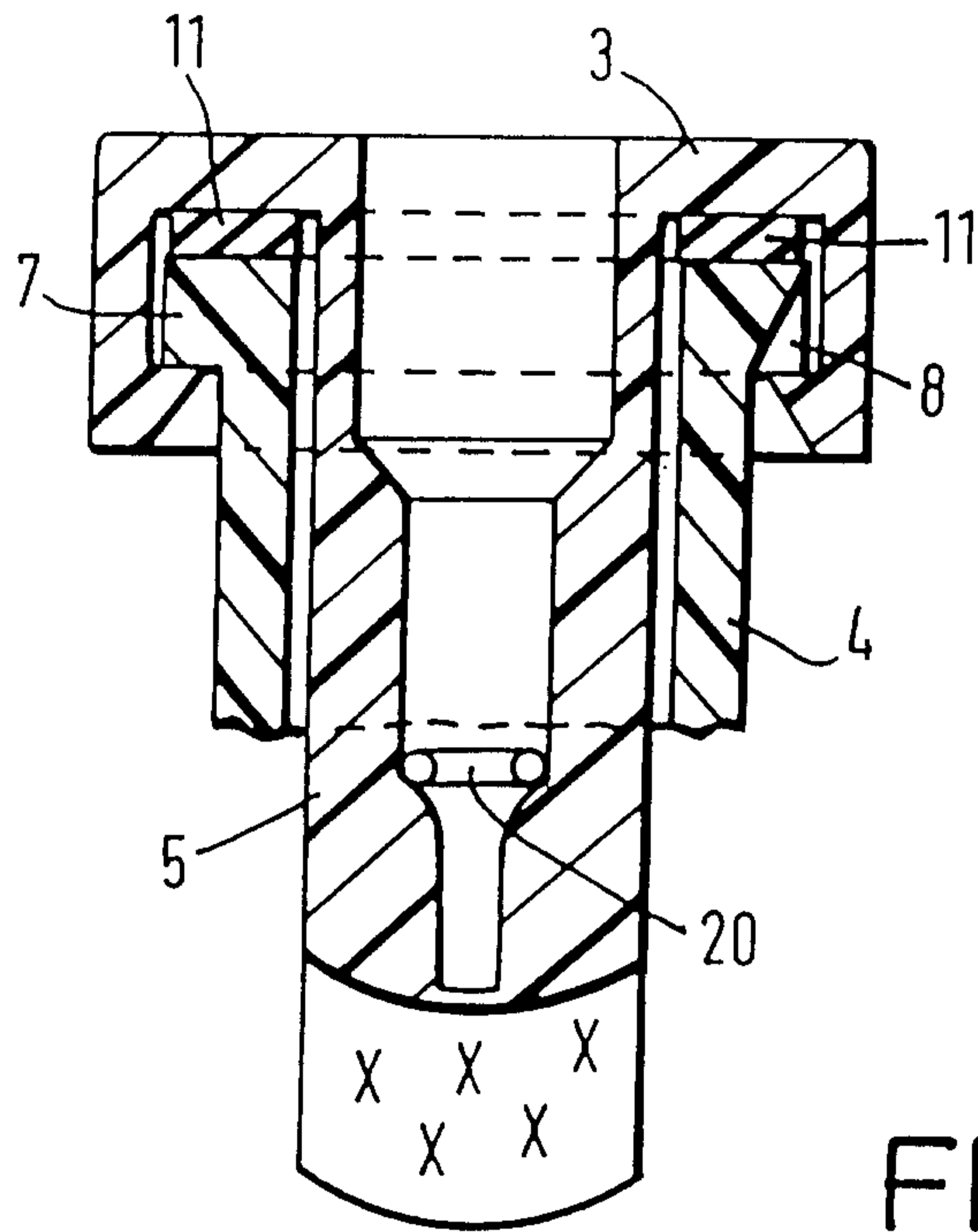

FIG. 3c

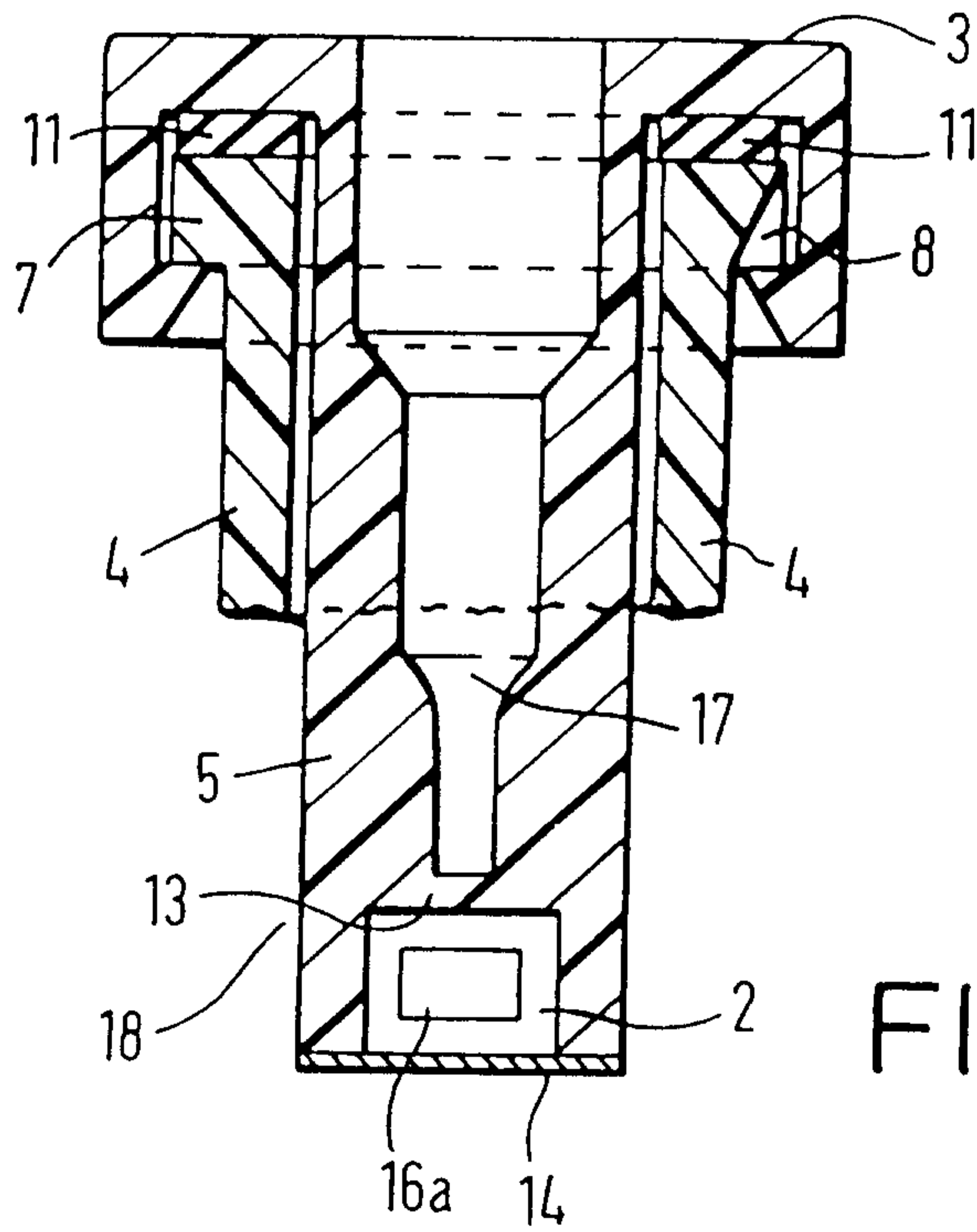

FIG. 4

