

[54] APPARATUS FOR MAKING A NON-WOVEN WEB FROM SYNTHETIC FIBERS

Primary Examiner—Dorsey Newton  
 Attorney, Agent, or Firm—Michael S. Striker

[75] Inventors: **Heinz Keib**, Wertheim am Main;  
**Fredo Schlachter**, Johannesburg,  
 both of Germany

[57] ABSTRACT

[73] Assignee: **Glaswerk Schuller GmbH**,  
 Wertheim am Main, Germany

A receptacle accommodates an aqueous suspension of synthetic fibers and has an inlet for the suspension and an outlet spaced from the inlet and through which the suspension flows. A liquid-permeable forming wire extends beneath the outlet and is arranged to travel at an angle upwardly across the outlet, so that emerging suspension is intercepted by the forming wire and the liquid component runs off through the same while the fiber component forms a web thereon. A turbulence-creating arrangement is provided, comprising bars or bar-shaped members extending into the receptacle intermediate the inlet and the outlet to create turbulence in the suspension flowing towards the latter. Some of these members are tubular and provided with outlets through which filaments or filament strands that have been admitted into the interior passages of the tubular members outside the receptacle, issue into the suspension to be carried along the same through the outlet so as to become embedded in the web which forms on the forming wire for the purpose of reinforcing the web.

[22] Filed: Feb. 7, 1974

[21] Appl. No.: 440,469

[30] Foreign Application Priority Data

Feb. 8, 1973 Germany..... 2306143

[52] U.S. Cl. .... 19/156; 19/66 R

[51] Int. Cl.<sup>2</sup> ..... D04H 5/00

[58] Field of Search..... 19/66 R, 155, 156;  
 162/136, 216, 156, 153, 341, 342

[56] References Cited

UNITED STATES PATENTS

2,904,461	9/1959	Washburn et al.....	162/216
3,293,116	12/1966	Opderbeck et al. ....	162/216
3,758,375	9/1973	Kerb et al.....	162/216 X

11 Claims, 4 Drawing Figures

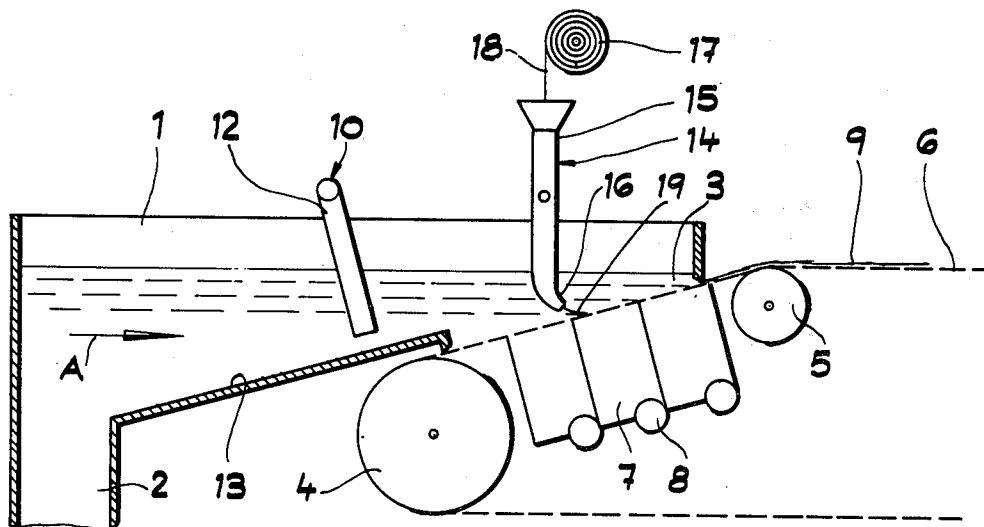



FIG. 3

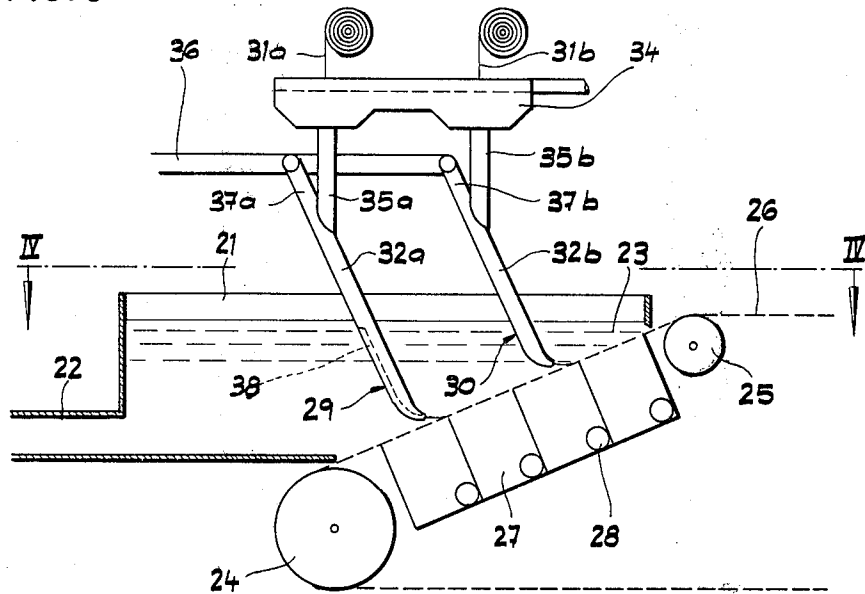
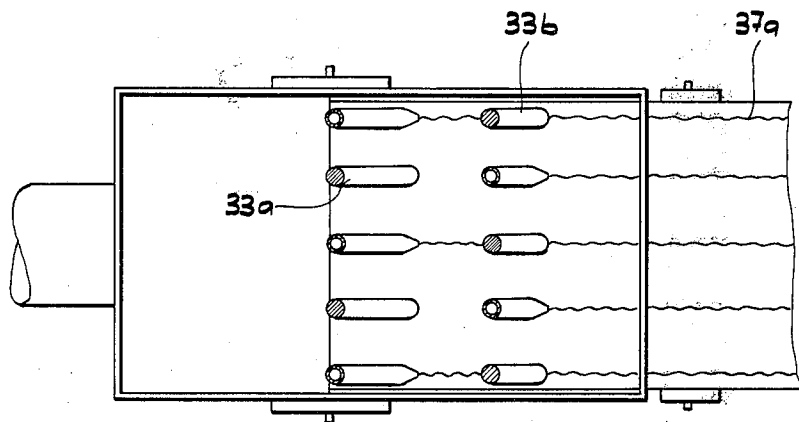

FIG. 4



## APPARATUS FOR MAKING A NON-WOVEN WEB FROM SYNTHETIC FIBERS

### BACKGROUND OF THE INVENTION

The present invention relates generally to an apparatus for making a non-woven web from synthetic plastic fibers, and more particularly to an apparatus for making a non-woven web which is reinforced.

It is already known to provide an apparatus for making non-woven webs from synthetic fibers, particularly glass fibers, wherein a receptacle has an inlet and an outlet and accommodates a suspension of fibers in water. Suspension is admitted through the inlet and flows through the receptacle to leave the same through the outlet. A forming wire extends beneath the outlet and travels at an upward angle across the same. The forming wire is liquid-permeable so that the liquid component of the aqueous suspension which runs out through the outlet can pass through the forming wire and run off, whereas the retained fibers form on the forming wire a non-woven web. The removal of the water can be facilitated by providing suction devices at the underside of the forming wire, so as to remove as much liquid as possible from the fibrous web which travels on the advancing forming wire. This web is then subjected to further processing, for instance drying steps, smoothing and the like, until it reaches the desired final state.

This prior-art apparatus potentially represents a highly advantageous approach to the making of non-woven webs from synthetic fibers. However, difficulties are experienced with it in certain circumstances. In particular, it is well known that the strength of the web, that is its resistance to disintegration, is greatly increased if the web contains relatively long fibers, for instance fibers in excess of 60 mm or the like. However, it has been found that if an attempt is made to use such fibers in the prior-art apparatus described above, these fibers tend to bunch together in the reservoir from which the aqueous suspension is supplied to the receptacle, and subsequently in the receptacle itself during their travel to the outlet thereof. It has been found in practice that this problem can be counteracted to some extent by significantly reducing the proportion of fibers to water in the suspension. This, on the other hand, has the disadvantage that very large quantities of water must be removed during the production of the non-woven web on the forming wire, and of course this water must be circulated through the forming wire, withdrawn through the forming wire from the web being formed, and either discarded and replaced with new water or else be returned to the reservoir wherein the suspension is being produced.

It has been proposed in the prior art to avoid some of these disadvantages by making a non-woven web exclusively or predominantly of endless filaments which are supplied in a stream of liquid through a channel which extends up to the forming wire. The flow speed of the filaments is to be greater than the speed at which the forming wire advances. It was proposed that the channel or channels should be of circular cross section and that the filaments should be supplied in the form of strands, with the channel gradually changing its shape to form a rectangular outlet at the forming wire, so that the filaments of the strand would be distributed over the width of the outlet before becoming deposited onto the forming wire. It has been found, however, that the flow of liquid in such channels is substantially dis-

turbed by the presence of these filaments, especially if some percentage of the filaments are short fibers which are to be admixed with the endless filaments. It was also found that at different operational speeds of an apparatus of this type, the formation of the web will vary due to the fact that the cross section of the channel varies in the flow direction of the filaments.

In particular, this type of apparatus cannot be used in the application with which the present invention is specifically concerned, namely the formation of a non-woven web which is predominantly constituted by relatively long fibers in which endless filaments or filament strands are to be embedded for reinforcing purposes.

### SUMMARY OF THE INVENTION

Accordingly, it is an object of the present invention to overcome the disadvantages of the prior art.

More particularly, it is an object of the present invention to provide an improved apparatus for making a non-woven web from synthetic fibers, which avoids the aforementioned disadvantages.

An additional object of the invention is to provide such an apparatus which is particularly well suited for making non-woven webs from glass fibers, but is not limited to the use of these particular fibers.

In keeping with the above objects, and with others which will become apparent hereafter, one feature of the invention resides in an apparatus for making a non-woven web from synthetic fibers. The apparatus comprises a receptacle for accommodating an aqueous suspension of synthetic fibers, the receptacle having an inlet for the suspension and an outlet spaced from the inlet and through which the suspension flows. A liquid-permeable forming wire extends beneath the outlet and is arranged to travel at an angle upwardly across the same, so that emerging suspension is intercepted by the forming wire and the liquid component runs off through the same while the fiber component forms a web thereon. Turbulence-creating means extends into the receptacle intermediate the inlet and the outlet to create turbulence in the suspension flowing towards the latter. It comprises a plurality of members at least some of which are formed with passages through which filamentary material can be discharged into the suspension so that such filamentary material can be discharged into the suspension so that such filamentary material becomes embedded in the web for reinforcing the same.

The novel features which are considered as characteristic for the invention are set forth in particular in the appended claims. The invention itself, however, both as to its construction and its method of operation, together with additional objects and advantages thereof, will be best understood from the following description of specific embodiments when read in connection with the accompanying drawing.

### BRIEF DESCRIPTION OF THE DRAWING

FIG. 1 is a diagrammatic vertical section through one embodiment of the invention;

FIG. 2 is a top-plan view of FIG. 1;

FIG. 3 is a view similar to FIG. 1, but illustrating a further embodiment of the invention; and

FIG. 4 is a section taken on line IV—IV of FIG. 3.

### DESCRIPTION OF THE PREFERRED EMBODIMENTS

Referring firstly to the embodiment illustrated in FIGS. 1 and 2, it will be seen that reference numeral 1 identifies a receptacle having an inlet 2 and an outlet 3 which is spaced from the inlet 2. The inlet 2 is connected in known manner via a supply conduit (not illustrated) with a source of an aqueous suspension of synthetic fibers, for instance glass fibers. As indicated by the arrow in FIG. 1, this suspension flows in the direction of the arrow A to and through the outlet 3.

Extending across the outlet 3 is a forming wire 6 which is trained about transporting rollers 4 and 5. Either of these rollers may be driven, or additional non-illustrated rollers may be provided that are driven in order for the forming wire to travel in clockwise direction. The term "forming wire" here refers to a screen-like belt or the like which is water permeable. Arranged beneath that portion of the forming wire 6 which extends across the outlet 3, are suction boxes 7 or other suction devices which are provided with outlet conduits 8.

As the suspension issues from the outlet 3, the aqueous component of the suspension runs off through the forming wire 6, being aided by the suction which exists beneath the latter, and this water is then carried away via the conduits 8. The solid component of the suspension, that is the fibers, becomes deposited on the upper surface of the forming wire to form a non-woven fibrous web, that is a fleece-like mat 9 which travels away from the outlet 3 on the advancing forming wire 6 and has been largely freed of water due to the suction effect of the suction boxes 7.

A rake-like or comb-like element 10 is provided which extends with its essentially rod-shaped members 12 into the suspension accommodated in the receptacle 1. The members 12 are bars of circular cross section in this embodiment, and are mounted on a cross-member 11 which can be secured in the diagrammatically illustrated manner (see FIG. 2) for pivoting about the longitudinal axis of the member 11. Thus, the inclination of the members 12 with respect to the body of suspension in the receptacle 1 can be varied. This could be done by means that are known per se and do not form a part of the present invention. Of course, the element 10 could also be fixedly mounted. Because the members 12 restrict the free flow-through cross section of the receptacle 1 intermediate the inlet 2 and the outlet 3 thereof, the flow speed of suspension between the members 12 is increased. This causes in the region downstream of the respective members 12, that is intermediate the members 12 and the outlet 3, a sufficiently strong turbulence in the flowing suspension to assure that any agglomerations of fibers which may have previously formed become dissolved, so that the individual fibers are freed and are again re-distributed in the suspension and at the same time assume random position, rather than being longitudinally oriented as may have occurred.

A second element 14 is provided in the embodiment of FIGS. 1 and 2 which also is composed of individual rod-like members 15 that are connected on a common cross member 20 which may be mounted fixedly or tiltably in known manner. Unlike the members 12, however, the members 15 are tubular and each have an upper inlet end and a lower outlet end 16, the cross sec-

tion of their passage being convergent from the inlet end towards the outlet end 16. The outlet end 16 is, incidentally, so shaped as to be inclined towards the plane of the forming wire 6 where the latter passes across the outlet 3, as illustrated in FIG. 1. The purpose of the tubular members 15 is to admit through them individual filaments or strands of filaments 18 which are withdrawn from supply spools 17 or which may even be derived in other ways. The purpose of the filaments 18 is to become embedded in the web 9 and to form reinforcements 19 therein. As they issue from the outlet ends 16, they are taken along by the suspension flowing in the direction of the arrow A, since the outlet ends 16 are of course located in the suspension as shown in the drawing. The suspension carries the filaments along and deposits them on the forming wire 6 together with the shorter fibers forming the web.

If the member 20 is pivotably mounted, this has the advantage of permitting a variation of the turbulence effect produced by the members 15 —which is of course also an important consideration since it reinforces the effect of the members 12— and also of permitting the spacing of the embedded reinforcements 19 from the upper or underside of the web 9, that is to control the depth at which the reinforcements 19 become embedded in the web.

A further embodiment of the invention is illustrated in FIGS. 3 and 4. It is generally reminiscent of that in FIGS. 1 and 2 and has a receptacle 21 provided with an inlet 22 and an outlet 23. The forming wire is here identified with reference numeral 26 and travels around the rollers 24 and 25. Suction boxes 27 are provided with outlet conduits 28.

Two elements 29 and 30 dip into the suspension in the receptacle 21, analogously to the elements 10 and 15 of FIG. 1.

In this embodiment, however, each of the elements 29 and 30 is composed of alternately arranged tubular members 32a, 32b and circular cross-section rods 33, 33b. The tubular members guide filaments 31a, 31b into the suspension. The supply of filaments in this case is via nipples 35a, 35b which are connected with a water reservoir 34 through which the filaments 31a, 31b pass. The extensions of the tubular members 32a, 32b are connected to conduits 37a, 37b which are connected with a common supply conduit 36 for water under pressure.

The embodiment in FIGS. 3 and 4 of course supplies the filaments or filament strands 31a, 31b in flowing water into the suspension, since water flows with the filaments through the tubular members 32a, 32b. This avoids the inclusion of air which otherwise might exit in form of air bubbles from the outlet ends of the tubular members and might interfere with the proper deposition of the fibers or of the suspension of the forming wire 26 in the region of the outlet 23.

A further advantage of this arrangement is the fact that water under higher pressure can be supplied through the conduit 36, which is admitted via the conduits 37a, 37b into tubular members 32a, 32b, and thus serves to accelerate the flow of water through these tubular members, that is the water which is derived from the nipples 35a, 35b and which carries the filaments 31a, 31b. This acceleration has the advantage that the filaments or filament strands 31a, 31b issue from the outlet ends of the tubular members 32a, 32b at a speed which is greater than the flow speed of the suspension,

with the result that the advancing filaments undergo a sudden retardation as they enter the more slowly streaming suspension, so that they become bowed either in the outlet and/or on the upper surface of the forming wire, rather than remaining completely straight. This is desirable in terms of the overall effect which the thus embedded filaments have on the web. Alternately, if a sufficiently large speed differential exists between the exiting filaments with respect to the speed at which the forming wire travels, the filaments 37a (see FIG. 4) might even be made to assume a wavy configuration in the web in which they are becoming embedded.

It will be appreciated that various modifications can be made in the illustrated exemplary embodiments without departing from the invention. Thus, it would be possible to construct all tubulence-producing members of the element 10 of FIG. 1 or the elements 29, 30 of FIG. 3 as tubular members, and to close off the outlet ends of those tubular members through which filaments are not to be introduced into the suspension, for instance by means of an appropriate plug. Water under pressure could be supplied directly to the reservoir 34, instead of to the tubular members. It is also possible to provide the tubular members 15 and 32a, 32b, of which the latter two would be without a separate supply of water under pressure if pressurized water is supplied directly to the reservoir 34, with slots 38 which face upstream with respect to the flow of the suspension, that is towards the inlet. In this case, the aqueous fibrous suspension can flow into the respective tubular members through the slot, and already act in the tubular members as a guide, surrounding to a certain extent the filaments with fibers, which would be advantageous in terms of the connection of the filaments with the fibers in the web in which they are to be ultimately embedded. If such slots 38 are provided, it is advantageous—in order to avoid the entry and formation of air bubbles in the tubular members having the slots—that the slots extend only below the level of suspension in the reservoir and continue to the outlet of the respective tubular member. Again, they need not absolutely continue to the outlet, but it is advantageous that they should definitely begin below suspension in the receptacle. The tubular members may alternate with solid cross section members, or groups of tubular members may alternate with groups of solid cross section members. Evidently, the members could be mounted individually, rather than as part of an element, such as the element 10 of FIG. 1, wherein they are all combined to form a single unit. The cross section of the solid cross section members is advantageously circular, but could be of a different shape.

It will be understood that each of the elements described above, or two or more together, may also find a useful application in other types of constructions differing from the types described above.

While the invention has been illustrated and described as embodied in an apparatus for forming a non-woven web from synthetic fibers, it is not intended to be limited to the details shown, since various modifications and structural changes may be made without departing in any way from the spirit of the present invention.

Without further analysis, the foregoing will so fully reveal the gist of the present invention that others can, by applying current knowledge, readily adapt it for var-

ious applications without omitting features that, from the standpoint of prior art, fairly constitute essential characteristics of the generic or specific aspects of this invention and, therefore, such adaptations should and are intended to be comprehended within the meaning and range of equivalence of the following claims.

What is claimed as new and desired to be protected by Letters Patent is set forth in the appended claims.

1. An apparatus for making a non-woven web from synthetic fibers, comprising a receptacle for accommodating an aqueous suspension of synthetic fibers, said receptacle having an inlet for said suspension and an outlet spaced from said inlet and through which said suspension flows in a path; a liquid-permeable forming wire extending beneath said outlet and being arranged to travel at an angle upwardly across the same, so that emerging suspension is intercepted by said forming wire and the liquid component runs off through the same while the fiber component forms a web thereon; and turbulence-creating means extending into said receptacle and intersecting said path intermediate said inlet and said outlet to create turbulence in the suspension flowing towards the latter, said turbulence-creating means comprising a plurality of members spaced along a line extending transverse to said path so as to form channels therebetween, and at least some of said members being formed with passages through which filamentary material can be discharged into said suspension so that such filamentary material becomes embedded in said web for reinforcing the same.

2. An apparatus as defined in claim 1, wherein said members which are formed with passages are tubular members.

3. An apparatus as defined in claim 2, wherein said tubular members have inlets; and further comprising conduit means communicating with said inlets and carrying water under pressure.

4. An apparatus for making a non-woven web from synthetic fibers, comprising a receptacle for accommodating an aqueous suspension of synthetic fibers, said receptacle having an inlet for said suspension and an outlet spaced from said inlet and through which said suspension flows; a liquid-permeable forming wire extending beneath said outlet and being arranged to travel at an angle upwardly across the same, so that emerging suspension is intercepted by said forming wire and the liquid component runs off through the same while the fiber component forms a web thereon; and turbulence-creating means extending into said receptacle intermediate said inlet and said outlet to create turbulence in the suspension flowing towards the latter, said turbulence-creating means comprising a plurality of members at least some of which are formed with passages through which filamentary material can be discharged into said suspension so that such filamentary material becomes embedded in said web for reinforcing the same, and a plurality of said members being connected with one another to form a comb-shaped unit.

5. An apparatus as defined in claim 4, wherein said unit is mounted for pivoting movement about a pivot axis which extends transversely of a line connecting said inlet and said outlet.

6. An apparatus as defined in claim 4, wherein others of said members are rods of substantially circular cross-section.

7

7. An apparatus as defined in claim 6, wherein said rods are arranged in said unit in alternation with said members which are formed with passages.

8. An apparatus as defined in claim 6, wherein groups of said rods are arranged in said unit in alternation with groups of said members which are formed with passages.

9. An apparatus for making a non-woven web from synthetic fibers, comprising a receptacle for accommodating an aqueous suspension of synthetic fibers, said receptacle having an inlet for said suspension and an outlet spaced from said inlet and through which said suspension flows; a liquid-permeable forming wire extending beneath said outlet and being arranged to travel at an angle upwardly across the same, so that emerging suspension is intercepted by said forming wire and the liquid component runs off through the same while the fiber component forms a web thereon; a reservoir which receives a constant flow of water; and turbulence-creating means extending into said receptacle intermediate said inlet and said outlet to create turbulence in the suspension flowing towards the latter, said turbulence-creating means comprising a plurality of members at least some of which are tubular and are formed with passages having inlets communicating with said reservoir and through which filamentary material is admitted, subsequent to passing through the water in said reservoir, and thereupon discharged into said suspension so that such filamentary material becomes embedded in said web for reinforcing the same.

10. An apparatus for making a non-woven web from

8

synthetic fibers, comprising a receptacle for accommodating an aqueous suspension of synthetic fibers, said receptacle having an inlet for said suspension and an outlet spaced from said inlet and through which said suspension flows: a liquid-permeable forming wire extending beneath said outlet and being arranged to travel at an angle upwardly across the same, so that emerging suspension is intercepted by said forming wire and the liquid component runs off through the same while the fiber component forms a web thereon; and turbulence-creating means extending into said receptacle intermediate said inlet and said outlet to create turbulence in the suspension flowing towards the latter, said turbulence-creating means comprising a plurality of members at least some of which are tubular and formed with passages through which filamentary material can be discharged into said suspension so that such filamentary material becomes embedded in said web for reinforcing the same, and at least some of said tubular members being formed with an axially extending slot which faces in the direction towards said inlet counter to the flow of said suspension.

11. An apparatus as defined in claim 10, wherein said tubular members have an upright orientation and each has an outlet opening through which said filamentary material passes into said suspension; and wherein said slots extend from the respective outlet opening axially of the tubular member to a level below the level of suspension in said receptacle.

\* \* \* \* \*

35

40

45

50

55

60

65