

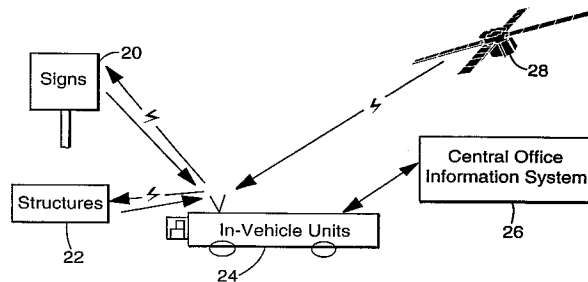

(72) BANTLI, Heinrich, US  
(72) IHLENFELDT, Lynn D., US  
(72) KRUSE, John M., US  
(71) MINNESOTA MINING AND MANUFACTURING COMPANY, US  
(51) Int.Cl.<sup>6</sup> G06F 19/00, G06F 17/60  
(30) 1995/05/01 (08/431,558) US  
(54) **SYSTEME AUTOMATISE POUR PARC DE PANONCEAUX**  
(54) **AUTOMATED SIGN INVENTORY SYSTEM**



(57) Dans un système d'automatisation de la maintenance et de la gestion de structures et de panonceaux routiers, on a équipé ceux-ci de répondeurs d'identification destinés à des communications électromagnétiques. En outre, ces panonceaux et structures sont pourvus d'une mémoire conservant les informations se rapportant à eux-mêmes. On a placé dans un véhicule une unité adaptable à tout véhicule, laquelle communique avec les répondeurs d'identification placés dans les panonceaux, afin d'identifier et de recevoir les informations provenant de ceux-ci. De plus, cette unité est dotée d'une mémoire de stockage des informations se rapportant à chaque panonceau. Un module d'emplacement et une interface graphique utilisateur aident au repérage et à l'identification des panonceaux. Après achèvement de l'installation du panonceau, de l'entretien ou de l'analyse des performances de celui-ci, on procède à une remise à jour de la mémoire du panonceau, de même qu'à une remise à jour de celle de l'unité placée à bord du véhicule. Une base de données centrale conserve les informations se rapportant à tous les panonceaux.

(57) A system for automating maintenance and inventory of roadway signs and structures equips such signs and structures with transponders for electromagnetic communication. Further, the signs and structures have a memory that stores information relating to the signs and structures. An in-vehicle unit is placed in a vehicle and communicates with the transponders in the signs to identify and receive information from the signs. The in-vehicle unit further has memory for storing information relating to each sign. A location module and graphical user interface assist in navigation and identification of signs. After installation, maintenance or evaluation of a sign is complete, the memory in the sign is updated as well as the memory in the in-vehicle unit. A central database stores information relating to all signs.

PCT

WORLD INTELLECTUAL PROPERTY ORGANIZATION  
International Bureau

## INTERNATIONAL APPLICATION PUBLISHED UNDER THE PATENT COOPERATION TREATY (PCT)

<p>(51) International Patent Classification <sup>6</sup> : G08G 1/00, G06F 17/60, G07C 3/00</p>	<p>A1</p>	<p>(11) International Publication Number: <b>WO 96/35196</b> (43) International Publication Date: 7 November 1996 (07.11.96)</p>
<p>(21) International Application Number: PCT/US96/05826 (22) International Filing Date: 26 April 1996 (26.04.96) (30) Priority Data: 08/431,558 1 May 1995 (01.05.95) US (71) Applicant: MINNESOTA MINING AND MANUFACTURING COMPANY [US/US]; 3M Center, P.O. Box 33427, Saint Paul, MN 55133-3427 (US). (72) Inventors: BANTLI, Heinrich; P.O. Box 33427, Saint Paul, MN 55133-3427 (US). IHLENFELDT, Lynn, D.; P.O. Box 33427, Saint Paul, MN 55133-3427 (US). KRUSE, John, M.; P.O. Box 33427, Saint Paul, MN 55133-3427 (US). (74) Agents: BARTINGALE, Kari, H. et al.; Minnesota Mining and Manufacturing Company, Office of Intellectual Property Counsel, P.O. Box 33427, Saint Paul, MN 55133-3427 (US).</p>	<p>(81) Designated States: AL, AM, AT, AU, AZ, BB, BG, BR, BY, CA, CH, CN, CZ, DE, DK, EE, ES, FI, GB, GE, HU, IS, JP, KE, KG, KP, KR, KZ, LK, LR, LS, LT, LU, LV, MD, MG, MK, MN, MW, MX, NO, NZ, PL, PT, RO, RU, SD, SE, SG, SI, SK, TJ, TM, TR, TT, UA, UG, UZ, VN, ARIPO patent (KE, LS, MW, SD, SZ, UG), Eurasian patent (AM, AZ, BY, KG, KZ, MD, RU, TJ, TM), European patent (AT, BE, CH, DE, DK, ES, FI, FR, GB, GR, IE, IT, LU, MC, NL, PT, SE), OAPI patent (BF, BJ, CF, CG, CI, CM, GA, GN, ML, MR, NE, SN, TD, TG).</p> <p><b>Published</b> <i>With international search report. Before the expiration of the time limit for amending the claims and to be republished in the event of the receipt of amendments.</i></p>	

(54) Title: AUTOMATED SIGN INVENTORY SYSTEM

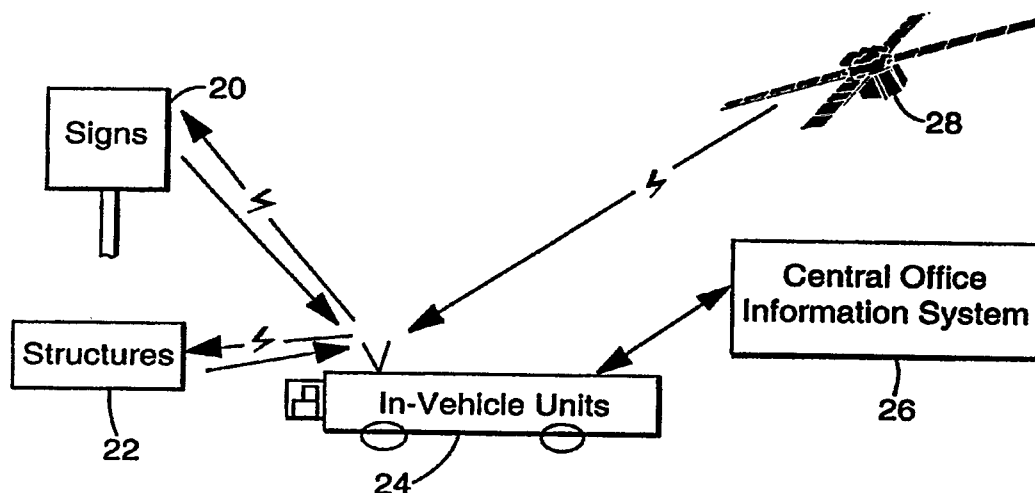

## (57) Abstract

A system for automating maintenance and inventory of roadway signs and structures equips such signs and structures with transponders for electromagnetic communication. Further, the signs and structures have a memory that stores information relating to the signs and structures. An in-vehicle unit is placed in a vehicle and communicates with the transponders in the signs to identify and receive information from the signs. The in-vehicle unit further has memory for storing information relating to each sign. A location module and graphical user interface assist in navigation and identification of signs. After installation, maintenance or evaluation of a sign is complete, the memory in the sign is updated as well as the memory in the in-vehicle unit. A central database stores information relating to all signs.

**AUTOMATED SIGN INVENTORY SYSTEM**Field of the Invention

The present invention relates to systems for automating maintenance and  
5 inventory of roadway signs and structures.

Background of the Invention

The many millions of roadway signs and structures necessary to keep  
roadways safe and traffic flowing present a particular logistical challenge for those  
10 responsible for the installation and maintenance of those signs and structures, such as  
department of transportation personnel. Signs and structures must be properly installed  
in the necessary locations and an inventory of those signs and structures must be  
maintained for future reference. Moreover, the signs and structures must be inspected  
on a periodic basis and maintained when necessary.

15 Field workers are dispatched on a periodic basis to inspect installed signs.  
The field workers must first determine what subset of all installed signs must be  
inspected. Then, the field workers must locate those large number of signs requiring  
inspection, assess the condition of those signs and document whether or not  
maintenance is necessary. Often when maintenance is necessary, the field worker  
20 performs the necessary repairs or replacements contemporaneously with the inspection  
and documents such maintenance activity. When performing such maintenance, it is  
further desirable to have available for the field workers information associated with each  
sign, such as installation date and past maintenance. Similarly, at a central office, such  
as a department of transportaion, it is also desirable to have available information  
25 associated with installed signs for purposes of recalls or replacement scheduling. The  
process of planning an appropriate inspection route for the field worker, evaluating the  
signs, assessing the inventory of signs and documenting necessary repair work or repair  
work performed can be an inefficient process with many opportunities for error in  
paperwork and location of signs.

30 With the ever increasing volume of traffic on roadways, there is a need  
for more efficient and safer traffic management. The need for local, unidirectional or bi-  
directional communication, involving specific vehicles and specific information, or  
between the roadside and vehicles, has been accomplished by various schemes. Some

-2-

schemes include directional antennas, selected radio frequencies, both continuous and pulsed, and signal encoding. Electronic road signs have been developed for such unidirectional or bi-directional communication between vehicles and the roadside, such as for in-vehicle signing. An electronic road sign has a surface with printed visual information for visual communication of desired information, such as toll collection, traffic control information or dangerous condition warnings. The electronic road sign also has a transmitter to electronically transmit information associated with the road sign. In-vehicle signing allows a vehicle on the roadway to electronically receive the information from the roadside transmitter and display the information inside the vehicle. Also, the information can be communicated by audio within the vehicle. The electronic road sign may also have a receiver to receive information from the vehicle, such as in toll collection to verify transactions, or from traffic management centers to update the message information to be delivered to a vehicle.

Electronic road signs are desirable because they effectively communicate information to vehicles in situations where visibility between the vehicle and the road sign is poor. The electronic road sign can provide redundant information to ensure the driver of a vehicle receives the information. For example, German Patent Application DE 41 42 091 A1 to Siemens Matsushita Components, filed August 5, 1993, describes an identification system for recognizing traffic information in vehicles, where an active transponder is placed inside a vehicle and a passive transponder is provided near a traffic sign, such as under the sign and mounted on the same post. What is further desirable is a retroreflective electronic road sign that enhances the optical visibility of the road sign, further improving the communication of information. Even more desirable is a integrated retroreflective electronic road sign. While a separate antenna may be placed alongside a road sign, or on the same mounting as a road sign, it is preferable to integrate the antenna or receiver with the road sign to prevent sign congestion on the road side, to be able to use existing infrastructure to implement the electronic road signs, for ease of installation, to reduce cost, to prevent tampering, and for safety considerations. Such an integrated retroreflective electronic road sign is described in commonly-assigned U.S. Patent Application Serial Number 08/196,294 to Bantli et al. and entitled "Integrated Retroreflective Electronic Display."

-3-

The United States Department of Defense has deployed a constellation of eighteen or more satellites into the earth's orbit as the central component to the Global Positioning System (GPS). GPS is well known and has many defense and civilian uses. From the deployed satellites, any user equipped with appropriate GPS receivers can determine their position anywhere in the world to within  $\pm 100$  meters. GPS receivers receive high frequency signals broadcast from the satellites and from the signals, can calculate their location. Error purposely induced into the system by the U.S. Department of Defense limits the accuracy of the GPS for civilian use to  $\pm 100$  meters. This GPS induced error varies over time.

#### Summary of the Invention

The present automated sign inventory system automates the maintenance and inventory process of objects such as roadway signs and structures. A mobile processing unit of the system stores information about signs to be installed, evaluated or maintained in a memory and allows a user to access such information as well as input additional information regarding specific signs. The signs and structures are equipped with electromagnetic communication means such as transponders as well as memory to store information relating to the specific sign. The system can identify individual signs through electromagnetic communication with the signs and structures, and can receive information from the signs. After installation, evaluation or maintenance of a sign, the memory in the sign can be updated as well. A central database also stores information relating to all signs and structures.

#### Brief Description of the Drawings

The present invention will be more fully described with reference to the accompanying drawings wherein like reference numerals identify corresponding components, and:

Figure 1 shows a typical roadway scene;

Figure 2 shows the general components of the inventory system of the present invention;

Figure 3a and 3b are example data field structures for a sign and a structure, respectively;

-4-

Figure 4a and 4b show cross-sectional and rear views of a sign having a transponder integrated into the sign;

Figure 5a and 5b show cross-sectional and rear views of another embodiment of a sign having a transponder integrated into the sign;

5 Figure 6 is a schematic diagram of a sign having a passive backscatter type transponder integrated into the sign;

Figure 7 is a schematic diagram of a sign having a read/write type transponder integrated into the sign;

Figure 8 is a schematic diagram of an in-vehicle unit;

10 Figures 9a through 9e are examples of touch screens used to display information and receive inputs from a user when the system is in an "Inventory" mode;

Figures 10a and 10b are examples of touch screens used to display information and receive inputs from a user when the system is in a "Maintenance" mode;

15 Figure 11 is an example of a touch screen used to display information and receive inputs from a user when the system is in a "Notes" mode; and

Figure 12 is an example of a touch screen used to display information and receive inputs from a user when the system is in a "Incidental Sign Evaluation" mode.

#### Detailed Description of a Preferred Embodiment

20 In the following detailed description of the preferred embodiment, reference is made to the accompanying drawings which form a part hereof, and in which is shown by way of illustration of a specific embodiment of which the invention may be practiced. It is to be understood that other embodiments may be utilized and structural changes may be made without departing from the scope of the present invention.

25 The system of the present invention is intended to assist department of transportation personnel with activity planning, record-keeping, and data entry in the activities of placing signs in the field, assessing their condition, and repairing or replacing them when necessary. The system results in an increased efficiency of the installation and maintenance activity with respect to signage and therefore can improve  
30 the overall safety of the transportation system. The system is not limited to roadway signs and the transportation system, however, and may be used for any number of structures installed by the roadway, such as guard rails, or other structures residing in

-5-

areas accessible to mobile units equipped with the inventory system of the present invention. Figure 1 shows a typical roadway scene with sign 2 installed beside roadway 4. Other structures are installed by roadway 4, such as guard rail 6 and light pole 8.

Figure 2 shows the general components of the inventory system. Signs 20 and structures 22 are installed next to roadways. Signs 20 and structures 22 are equipped with some means for communicating information electromagnetically, such as using radio frequency (RF) energy, as will later be described. In-vehicle units 24 are portable modules and are equipped with a variety of electronics for communicating with signs 20 and structures 22, for receiving location data from GPS satellite 28 or from a Geographic Information System (GIS), for downloading and receiving data from central office information system 26 as well as for processing and managing the information received from the different components of the system and the operator of the system. In one embodiment, communication between in-vehicle unit 24 and signs 20 and structures 22 is bi-directional communication while in another embodiment communication is unidirectional, to in-vehicle unit 24 from signs 20 and structures 22.

To improve the efficiency of locating signs and structures, performing inventory on installed signs, and maintaining those signs and structures, information associated with each sign and structure is programmed into memory installed in each sign or structure. Figures 3a and 3b show examples of data residing in the data fields of memory for a sign and a structure, respectively. Preferably, two types of information are programmed into the memory of signs and structures, permanent attributes and variable attributes. Permanent attributes are attributes that should not change with respect to a sign, and thus the information relating thereto can be programmed during manufacturing. For example in permanent attributes column 30 and 40 of the data fields for signs and structures, respectively, information such as the serial number of the sign or structure, where and when the sign was manufactured and the type of sign can be programmed into memory at the manufacturing location. Variable attributes are those attributes that can change, are not known at the time of manufacturing or are collected at installation sites, and thus the information relating thereto is programmed after manufacturing, such as at the installation site. In variable attributes column 32 and 42 of the data fields, information such as the authority responsible for maintaining the sign, the location of the sign or structure, the date of installation, and the status of the sign may

-6-

be programmed into memory. Moreover, after any repairs are made, a maintenance record stored in the memory of a sign can be updated, thereby providing a history of repairs with the sign or structure for field workers performing future maintenance.

As mentioned above, signs 20 and structures 22 are equipped with some means for communication with in-vehicle unit 24. In one embodiment, a transponder for RF communication can be installed on a separate support near sign 20 or more preferably on the infrastructure supporting sign 20 or structure 22. In a more preferred embodiment, however, the transponder is integrated with sign 20 or structure 22 to be able to use existing infrastructure to support the electronic road signs, for ease of installation, to reduce cost, to avoid tampering and for safety considerations. Moreover, if the transponder is integrated with sign 20 during manufacturing, it reduces the probability of error in programming at a field site.

Figures 4a and 4b show a cross-sectional view and a rear view, respectively, of a sign having a transponder integrated into the sign. Transponder 52 is preferably hidden from the view of drivers of vehicles and passerbys as well as inaccessible to vandals. Further, it is preferable to integrate transponder 52 into sign 50 during manufacturing rather than during installation of sign 50. Most road signs incorporate retroreflective sheeting on their front surface to provide improved visibility during the night. A high efficiency prismatic retroreflective sheeting has been developed by Minnesota Mining and Manufacturing Company, St. Paul, Minnesota, that provides total internal reflection of light rays within a clear dielectric material. The retroreflective sheeting has a first substantially flat side and a second side with an array of cube-corner elements thereon. An example of prismatic retroreflective sheeting is 3M brand Scotchlite™ Reflective Sheeting Diamond Grade. Another example is described in commonly-assigned U.S. Patent No. 4,588,258 to Hoopman issued May 13, 1986. Because the cube-corner retroreflective sheeting utilizes a dielectric material, it may be used as retroreflective sheeting 54 of sign 50 because it may be placed in front of transponder 52 without inhibiting the transmission of its radio signals.

Backing 56 of sign 50 is typically a metal substrate such as an aluminum substrate. A recess may be stamped into backing 56 at a predetermined, standard location for each sign for housing transponder 52. During manufacturing, transponder 52, after being programmed with the permanent attributes of sign 50, may be placed into

-7-

the recess of backing 56 and sealed into the recess with an adhesive or epoxy. The sealing can further be performed, if desired, such that transponder 52 cannot be easily removed from sign 50.

Other types of retroreflective sheeting are more commonly used with roadway signs, such as enclosed lens retroreflective sheeting and encapsulated lens type retroreflective sheeting. Enclosed lens retroreflective sheeting employs a monolayer of microspheres, typically glass beads, embedded in a binder layer with a transparent cover film. Underlying and spaced from the binder layer is a substantially continuous reflective coating. The continuous reflective coating is preferably vapor deposited aluminum. The substantially continuous reflective metal coating, however, acts as a conductive plane and therefore renders any RF communication means placed behind it ineffective for communication. Similarly, an encapsulated lens type of retroreflective sheeting, such as 3M brand Scotchlite™ Reflective Sheeting High Intensity Grade, manufactured by Minnesota Mining and Manufacturing Company, can render any RF communication means placed behind it ineffective for communication. An encapsulated lens type of retroreflective sheeting has a monolayer of microspheres, such as glass beads, partially embedded in a support layer of binder material. A substantially hemispherical reflective coating underlies and is in optical connection with the embedded surface of each microsphere. The reflective coating is preferably vapor deposited aluminum. Gaps exist between each substantially hemispherical reflective coating of each microsphere, thereby forming a discontinuous vapor coat layer. The microspheres may be encapsulated and hermetically sealed in pockets. Examples of such retroreflective sheeting are described in commonly-assigned U.S. Patent No. 3,190,178 to McKenzie issued June 22, 1965, and U.S. Patent No. 4,664,966 to Bailey et al. issued May 12, 1987.

Figures 5a and 5b show a cross-sectional view and a rear view, respectively, of a sign having transponder 62 integrated into sign 60, sign 60 having an enclosed lens or encapsulated lens type of retroreflective sheeting 64. Similar to sign 50 shown in Figures 4a and 4b, sign 60 has backing 66, preferably an aluminum substrate, having a recess in a predetermined, standard location for housing transponder 62. As described above, the vapor coat layer of retroreflective sheeting 64 inhibits the transmission of radio signals from transponder 62. Therefore, an RF window is provided for transponder 62. In one embodiment, an RF window is created by cutting

-8-

out a portion of retroreflective sheeting 64 to form a window. An equally sized and matching in color piece of prismatic retroreflective sheeting made of a dielectric material is placed over the window, thereby providing a fully retroreflective surface and having an RF window for transponder 62. While two embodiments of integrated retroreflective signs have been described, other signs having electromagnetic communication capabilities, such as described in the aforementioned Bantli et al. application entitled “Integrated Retroreflective Electronic Display” are contemplated for use with the present system.

Figure 6 is a schematic diagram of a sign having a transponder that can be used with the system of the present invention. Sign 70 has retroreflective sheeting 72 provided on its front face in a manner similar to Figures 4a or 5a. Transponder 74 is a passive, backscatter transponder. Passive transponders only allow for storage of information in memory 80. The information stored in memory 80 can be read at a later time but memory 80 cannot be programmed at a later time. Memory 80 of transponder 74 is preferably an electrically erasable programmable read-only memory (EEPROM) programmed at the manufacturer of the sign, the programmed information being similar to the aforescribed permanent attributes. Transponder 74 has an antenna for RF communication with another antenna, such as an antenna used with in-vehicle reader 82, as will later be described. Antenna 76 is preferably a microstrip patch antenna or a wire-coil antenna, although many types of antennas may be used. Passive, backscatter type transponders do not require a power source. Instead, such transponders are energized by incoming RF energy. Once energized, antenna 76 receives the RF energy and radiofrequency electronics 78 generate a DC voltage from the incoming, alternating signal. Radiofrequency electronics 78 then amplitude modulate the incoming signal with the binary information stored in memory 80, thereby providing in-vehicle reader 82 with the desired information.

Figure 7 is a schematic diagram of a sign having another transponder that can be used with the system of the present invention. Sign 90 has retroreflective sheeting 92 provided on its front face in a manner similar to Figures 4a or 5a. Transponder 94 is an active, read/write transponder, thereby allowing programming of memory 100 at both the time of manufacturing as well as at a later time, such as after sign 90 has been installed. Thus, transponder 92 allows storage of both permanent and

variable attributes. Because transponder 94 is an active transponder, it requires power source 104, such as a battery, to provide power to radiofrequency electronics 98 and signal processing electronics 102 and maintain the memory. To minimize power consumption, signal processing electronics 102 can be programmed not to transmit until  
5 RF energy above a certain threshold is received by antenna 96, such as would be received from an in-vehicle reader. Further, transponder 92 can shut itself off after a predetermined period of no transmission.

Similar to the antenna of transponder 74, antenna 96 may be any of a number of suitable antennas, such as microstrip patch antennas or wire coil antennas.  
10 Memory 100 preferably includes both an EEPROM for storage of permanent attributes as well as a volatile memory, such as a random access memory (RAM) for storage of variable attributes. The RAM preferably has a lithium backup battery in case of power loss from power source 104. Signal processing electronics 102 makes logic decisions based on instructions contained in the received signal and executes the transmission  
15 protocol. Moreover, it formats the message into a digital bit stream to be transmitted, the formatted message sent to the transmit circuit of radiofrequency electronics 98. Signal processing electronics 102 may include a receiver decoder for decoding the digital signal into a binary bit stream, a protocol logic unit for decoding the protocols and may also include electronics monitoring the status of power source 104.  
20 Radiofrequency electronics includes those components well known in the art such as modulation and demodulation circuits for converting signals between digital and analog formats, a field strength detector, a receive detector, and a decoder for receiving signals and a transmit oscillator/modulator and a transmit power amplifier for transmitting the modulated RF voltage to antenna 96.

25 Figure 8 is a schematic diagram of in-vehicle unit 110, preferably installed in a vehicle as shown in Figure 2. The core elements of in-vehicle unit 110, which is a portable module for data processing and electromagnetic communication, are a computer system which has data regarding signs to be placed, evaluated or maintained as well as a user interface which allows personnel using the system to read and input  
30 information about the signs, and a communications module that can identify individual signs from a moving vehicle. The computer system includes central processing unit (CPU) and software 116 and internal memory 118 consisting of read-only memory

-10-

(ROM) and RAM. The CPU and related software 116 read the inputs from various ports and devices and process the inputs according to the specifications of the system. The communications module includes antenna 112 and RF electronics 114. Antenna 112 preferably is a microstrip antenna that can be adhered to the windshield of a vehicle. Alternatively, antenna 112 can be incorporated into the in-vehicle unit and the entire unit can be placed onto the vehicle dashboard. RF electronics 114 include modulation and demodulation circuits for converting signals between digital and analog formats. Power supply 120 provides power for both the computer system and the communications module. Battery backup 140 provides power to the system in the event that power supply 120 fails.

In a preferred embodiment, in-vehicle unit 110 includes additional components. User display 122, such as a computer monitor or an LCD display provides images and information to the user. Input device 124, such as a keyboard or mouse and pointer, is used by the department of transportation personnel to request desired information and input other commands. In a preferred embodiment, user display 122 and input device 124 are combined in a single unit, as a touch screen with a graphical user interface. An example of such a unit and its operation will later be described. Further, audible signal module 126 can provide audible signals to the user in situations where the user's attention is required, such as when a desired sign is approaching. Further, removable memory 128, such as a diskette or a smart card, allows related information to be stored and modified in a single memory unit that can be inserted when needed and removed and stored at a central office when not needed. Further, voice input module 130 allows the user, typically who is driving a vehicle, to input voice commands rather than manual input of commands. Printer port 138 allows connection of the in-vehicle unit 100 to a printer to provide hard copies of information.

Location module 136 may be a GPS module that computes the in-vehicle unit's location. A GPS module receive a GPS signal from the GPS satellites and processes the signal to determine various navigational data regarding the vehicle, such as the vehicle's position, heading and velocity. Thus, location module 136 further can correlate the in-vehicle unit 110 location to information regarding sign locations stored in the computer system's database. Location module 136 can utilize other well known technologies instead of the GPS system. Examples of these include location beacons

-11-

that broadcast specific locations to a small-radius area through which the controlled vehicle passes, Loran C, a ground based system similar to GPS, or dead reckoning. Reflectometer port 132 allows unit 110 to receive information from a reflectometer, thereby allowing the unit to make determinations on the condition of the retroreflective sheeting on the signs. Communication port 134 allows the uploading and downloading of information from a central database, such as from a database residing at a central office.

The above-described components preferably interact in the following manner. A central database resides in a central office information system and has stored in it information relating to signs, including their location and an identification code or serial number for each sign in the inventory. A department of transportation worker is tasked with driving past a number of predetermined signs, such as all signs on a selected number of roads, visually inspecting them for readability and entering an evaluation into the computer system residing in the in-vehicle unit. Before leaving the central office, information is transferred from the central database to the in-vehicle unit through the unit's communication port. Additionally, routing information may be included as a portion of the data transferred to the in-vehicle unit to provide navigational assistance to the worker through the evaluation session. If the in-vehicle unit includes a GPS module, the module continuously computes the relative vehicle location with respect to the target signs. The module and associated software can alert the worker when a sign is approaching, through a graphical display or an audible signal or both. After verifying a sign's contents and visually evaluating a sign, the worker can input an evaluation of the sign. Further, other evaluations of the sign are stored to memory, the evaluations made or received by other modules such as the information relating to the retroreflectivity of the sign received from the reflectometer. The identification number associated with a sign and the input assessment of the condition of the sign is stored in the in-vehicle unit's memory for later uploading to the central database at the central office.

In one embodiment of the present invention, the signs and structures do not contain any communication means to communicate with the in-vehicle unit. In such an embodiment, the in-vehicle unit preferably contains information relating to the location of each sign and structure and the type of sign or structure. This information is recorded in a central database which is updated when new signs or structures are

installed. The in-vehicle unit preferably contains routing information for guiding a worker through a path, and even more preferably contains a GPS module for computing the relative vehicle locations with respect to the target signs and alerting the worker when signs are approaching.

5                   In another embodiment of the present invention, signs and structures are equipped with transponders similar to the transponder shown in Figure 6. Because these transponders are passive and cannot be programmed, a central database contains the same permanent information as the signs and is the only source of information regarding the variable attributes of the signs. Therefore, before the in-vehicle unit is deployed,  
10 both the permanent and the variable information is uploaded from the central database to the in-vehicle unit. Once deployed, the in-vehicle unit interrogates a sign and reads the permanent information from the sign. The in-vehicle unit searches the uploaded data from the central database and identifies the sign and displays the variable information. The worker then can perform the evaluation and input the assessment. Similarly, when a  
15 sign is installed or repaired, the worker inputs the variable information, such as location and date of installation or type of maintenance performed, into the in-vehicle unit memory which is later downloaded to the central database.

                  In yet another embodiment of the present invention, a transponder similar to the transponder shown in Figure 7 is installed in signs and structures. As described  
20 above, these transponders are read/write transponders, allowing storage of both permanent and variable attributes. A central database in a central office may still maintain both the permanent and variable attributes. In such a situation, however, the database content is duplicative of the information stored in the signs. In such a system, when a worker performs evaluation tasks, it is not necessary to upload the duplicated  
25 information. Only a limited amount of data, such as routing information or other work instruction, need be uploaded to the in-vehicle unit from the central database. When approaching a sign, the in-vehicle unit interrogates the sign, which responds by transmitting both permanent and variable information to the unit. After installation, evaluation or maintenance of the sign or structure, the in-vehicle unit programs the sign  
30 with the necessary new variable data and the same data may later be downloaded to update the central database. The central office information system then can perform a

number of functions, such as update work logs, financial information, and sign inventories, and calculate projected work such as replacement schedules.

As described above, in a preferred embodiment of the in-vehicle unit, the user interface and input device are combined in a single touch screen device, wherein a screen displays information to the user and allows the user to input commands by touching an area of the screen having an icon indicating the desired command. Figures 9a through 9e show example screens of the user interface used in such a preferred embodiment when performing an inventory function. Figure 9a shows an inventory screen which graphically shows the next three signs the vehicle carrying the in-vehicle unit will encounter, namely, signs 152, 154, and 156. The screen also shows the distances to each sign from the vehicle's current position. The current distances are "500", "515", and "540", the numbers decreasing as the vehicle moves toward the signs. Horizontal line 158 shows an abstract one-dimensional map of the vehicle's route, with signs equipped with a read/write or passive, backscatter type of transponder, or "smart" transponders, indicated by striped lines, such as signs 152, 154 and 156, and signs not equipped with any transponder indicated with a shorter solid line, such as sign 160. Intersecting roads 162 and 164 can also be shown on the map. For such a display, the in-vehicle unit must have a GPS module or other GIS module to provide the location information and the central database must include information of sign locations and road locations. The top row of icons allows the user to select among various screens by touching the screen where the icon is displayed. Icon 166 selects the "Inventory" screen, which is currently selected, as indicated by the thicker black box surrounding icon 166. Icon 168 selects the "Maintenance" screen and icon 170 selects the "Notes" screen. A "Help" icon 172 may also be provided.

Figure 9b is an example of the "Inventory" screen when the vehicle equipped with the in-vehicle unit is within a predetermined distance from the next sign to be evaluated. The predetermined distance is chosen such that the evaluator of the sign can adequately prepare to evaluate the sign. At this point, an audible signal may also be emitted from the in-vehicle unit. When a driver only needs to perform a visual inspection to indicate whether the state of the sign is acceptable, the driver can choose from two icons. Icon 180, having a check mark graphic, indicates that the condition of the sign appears acceptable to the driver. Icon 182, having a thumbs-down graphic,

-14-

indicates that the condition of the sign appears unacceptable to the driver. A third icon 184 recalls a sub-screen of information details on the subject sign. As seen in Figure 9b, the touch screen of the present system allows the driver to verify the sign's contents and evaluate the condition of the sign while driving, the evaluation input simply by using easily readable touch-sensitive menus on the screen. This allows efficient sign evaluation, as it obviates the need to stop the vehicle in most circumstances and eliminates error-prone paperwork.

Figure 9c shows an alternative Inventory screen, in which the locations of the vehicle and signs are displayed in two-dimensional space. Similar to the Inventory screen of Figure 9a, the next three signs are displayed graphically and the distance of the vehicle to those signs is also displayed. Additional information, such as intersecting roads, could also be provided.

Figure 9d shows the Inventory screen shown in Figure 9c when the vehicle has approached to within sufficient proximity to the next sign to allow the driver to perform an evaluation. Basic information 190 can be displayed, such as the serial number of the sign and the sign's date of installation. More detailed information can be accessed by touching information icon 192.

Figure 9e shows an example of an Inventory screen for an in-vehicle unit that is not equipped with a GPS module. Such a system will not have information regarding a vehicle's location until the vehicle encounters a sign of known location having a read/write transponder or other programmable communication means. The display for the driver cannot contain information about the location of the vehicle or the distance from the vehicle to the next sign. The screen can, however, list the signs in some geographically ordered manner, with distances from known locations or relative distances. Moreover, while the relative distances from the vehicle to signs could not be displayed, a map showing the location of each sign could be displayed (not shown). The inventory task could still be performed in a non-stop manner and the system could verify sign location and identity when it encountered a sign having a read/write transponder.

Figures 10a and 10b show example screens when the system is in a "Maintenance" mode. Figure 10a shows a geographic area, "Northwest Quadrant", and a set of signs that need maintenance work. After selecting an item from the list of signs, additional detailed information is displayed in box 200 to provide guidance to the user of

-15-

the necessary maintenance. After completing maintenance or installing a new sign, the user can press the check icon to indicate completion of the task and the system verifies it by signaling the sign and checking the response of the antenna. If more information is desired, the user can press the "i" button to request more information. Figure 10b is an example of some types of information that could be provided on an information screen.

The system of the present invention provides flexible user control over the user's activities and their sequence. For example, Figure 11 illustrates a situation where some anomalous condition is noted as the driver is performing scheduled inventory or maintenance activities. The driver presses the "Notes" icon 170 to request a variety of conditions. The user can press an icon next to the condition description 208 either in the high priority column 210, having an exclamation point "!" or the low priority column 212. If the condition does not exist as a preexisting condition on the list, the user can press "Other" and enter the specific condition. The system makes a record of the location and the type of problem and the report of such conditions is downloaded to the central database for later processing. Similarly, Figure 12 shows a screen a driver can recall if the driver's primary task is something other than inventory. Similar to the anomaly report illustrated in Figure 11, the driver can perform an unscheduled evaluation that is later downloaded to the central database.

Although a preferred embodiment has been illustrated and described for the present invention, it will be appreciated by those of ordinary skill in the art that any method or apparatus which is calculated to achieve this same purpose may be substituted for the specific configurations and steps shown. This application is intended to cover any adaptations or variations of the present invention. Therefore, it is manifestly intended that this invention be limited only by the appended claims and the equivalents thereof.

PCT/US96/05826  
Minnesota Mining and  
Manufacturing Company  
Our Ref.: A 2888 PCT

23 April 1997

VOSSIUS & PARTNER  
PATENTANWÄLTE  
81675 MÜNCHEN  
SIEBERTSTRASSE 4  
TELEFON 47 40 75

## CLAIMS:

1. A system for maintaining inventory control of a plurality of signs, said system comprising:
  - a plurality of electronic means, each associated with one of said plurality of signs, each electronic means for providing electromagnetic communication and for storing information relating to the associated one of said signs;
  - a central database for providing an inventory record of said plurality of signs, said inventory record including said information relating to each of said plurality of signs;
  - a portable module, comprising:
    - means for communicating with said plurality of electronic means ;
    - means for obtaining and inputting evaluation or assessment information regarding at least one of said plurality of signs;
    - means for communicating said evaluation or assessment information to said central database, such that the inventory record of said plurality of signs is maintained.
2. The system according to claim 1, further comprising a location module for determining the location of said portable module.
3. The system according to claim 2, wherein said location module utilizes the Global Positioning System.
4. The system according to claim 2, wherein said location module utilizes a geographic information system.
5. The system according to claim 1, wherein each of said electronic means comprises a programmable read only memory for storing permanent information.

6. The system according to claim 1, wherein each of said electronic means comprises a random access memory for storing variable information.
7. The system according to claim 1, wherein each of said electronic means is integrated with each associated sign.
8. The system according to claim 1, wherein each of said electronic means comprises a microstrip patch antenna.
9. The system according to claim 1, wherein each of said electronic means comprises a passive, backscatter type antenna.
10. The system according to claim 1, wherein said means for obtaining and inputting evaluation or assessment information comprises a display.
11. The system according to claim 1, wherein said means for obtaining and inputting evaluation or assessment information further comprises an input device.
12. The system according to claim 1, wherein said means for obtaining and inputting evaluation or assessment information comprises a touch screen for displaying information and for receiving inputs from a user.
13. The system according to claim 1, wherein said means for obtaining and inputting evaluation or assessment information provides audible signals to a user.
14. The system according to claim 1, wherein said portable module further includes a removable memory.

AMENDED SHEET

15. The system according to claim 1, wherein said signs have retroreflective sheeting and wherein said system further comprises a reflectometer for determining the condition of said retroreflective sheeting.

16. The system according to claim 1, further comprising means for providing routing information to a user.

17. The system according to claim 1, further comprising means for providing relative location of said portable module with respect to said signs.

1/14

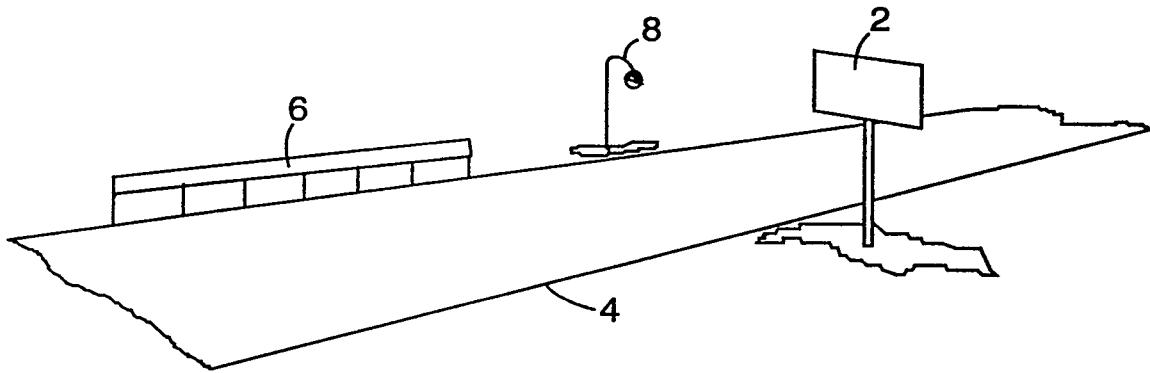

**Fig. 1**

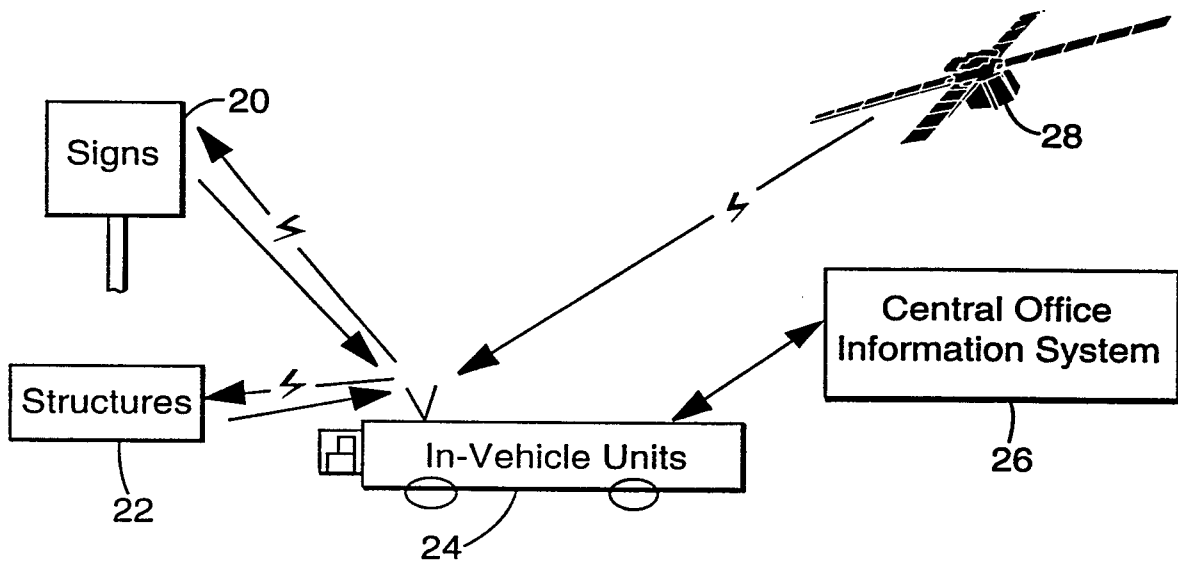

**Fig. 2**

30	$\frac{2}{14}$	32
<u>Permanent Attributes:</u>	<u>Variable Attributes:</u>	
• Sign Serial Number	• Responsibility for sign (jurisdiction)	
• Manufacturing Location	• Location of sign	
• Manufacturing Date	• Installation Date	
• Type of Sign	• Maintenance Record	
	• Status of Sign: Mechanical	
	• Status of Sign: Retroreflectivity	

**Fig. 3a**

40	42
<u>Permanent Attributes:</u>	<u>Variable Attributes:</u>
Structure Serial Number	• Type of Structure
	• Responsibility for structure (jurisdiction)
	• Location of structure
	• Installation Date
	• Maintenance Record
	• Status of Structure: Mechanical
	• Status of Sign: Reflectors (if any)

**Fig. 3b**

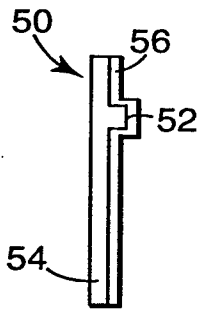

**Fig. 4a**

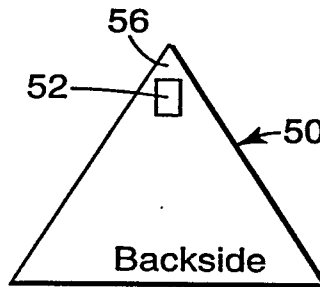

**Fig. 4b**

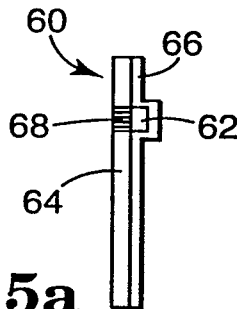

**Fig. 5a**

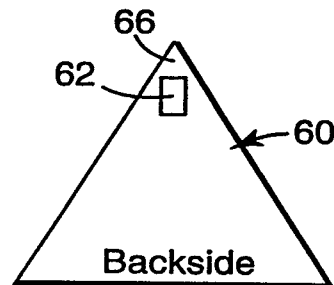

**Fig. 5b**

3/14

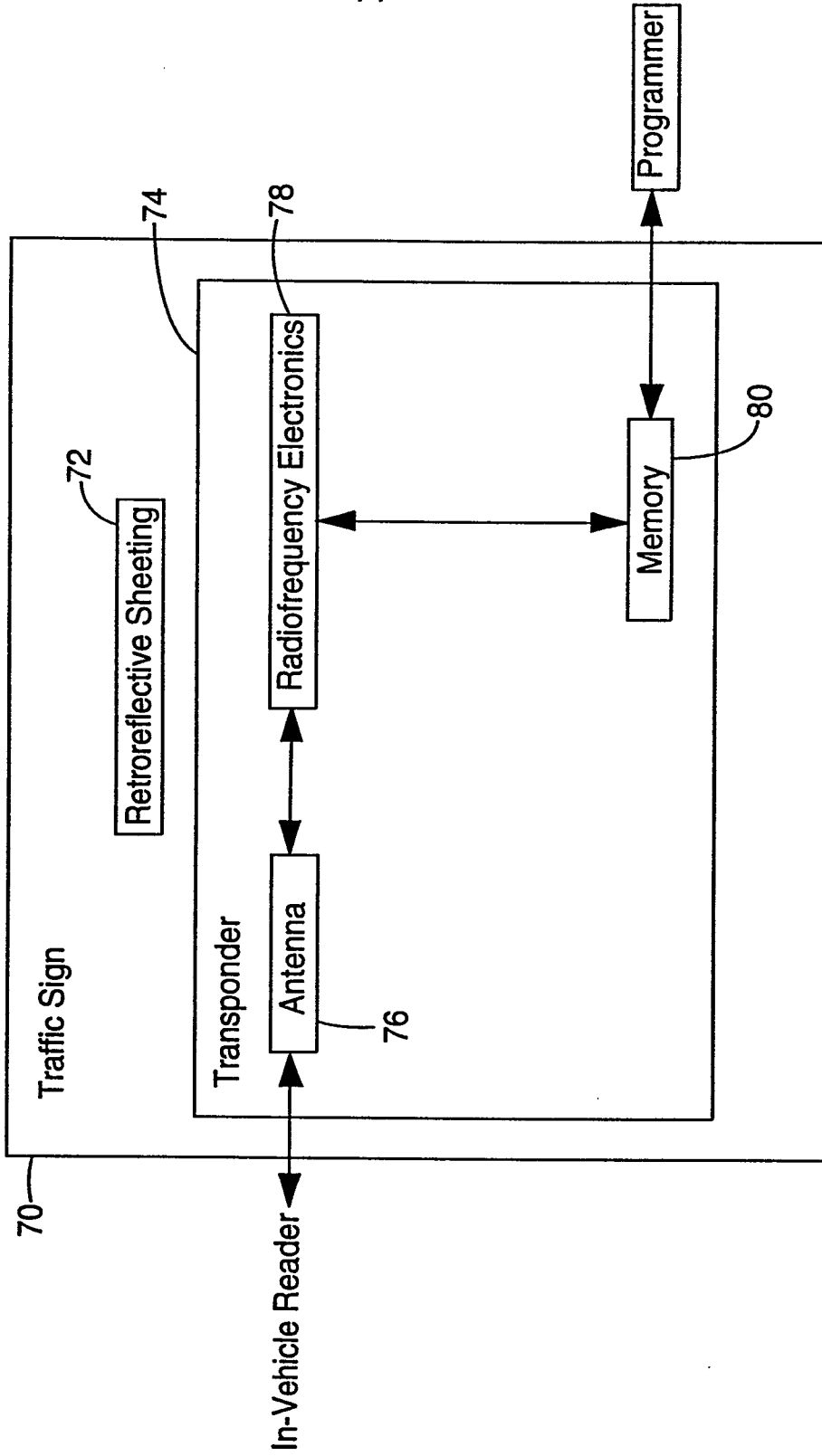

Fig. 6

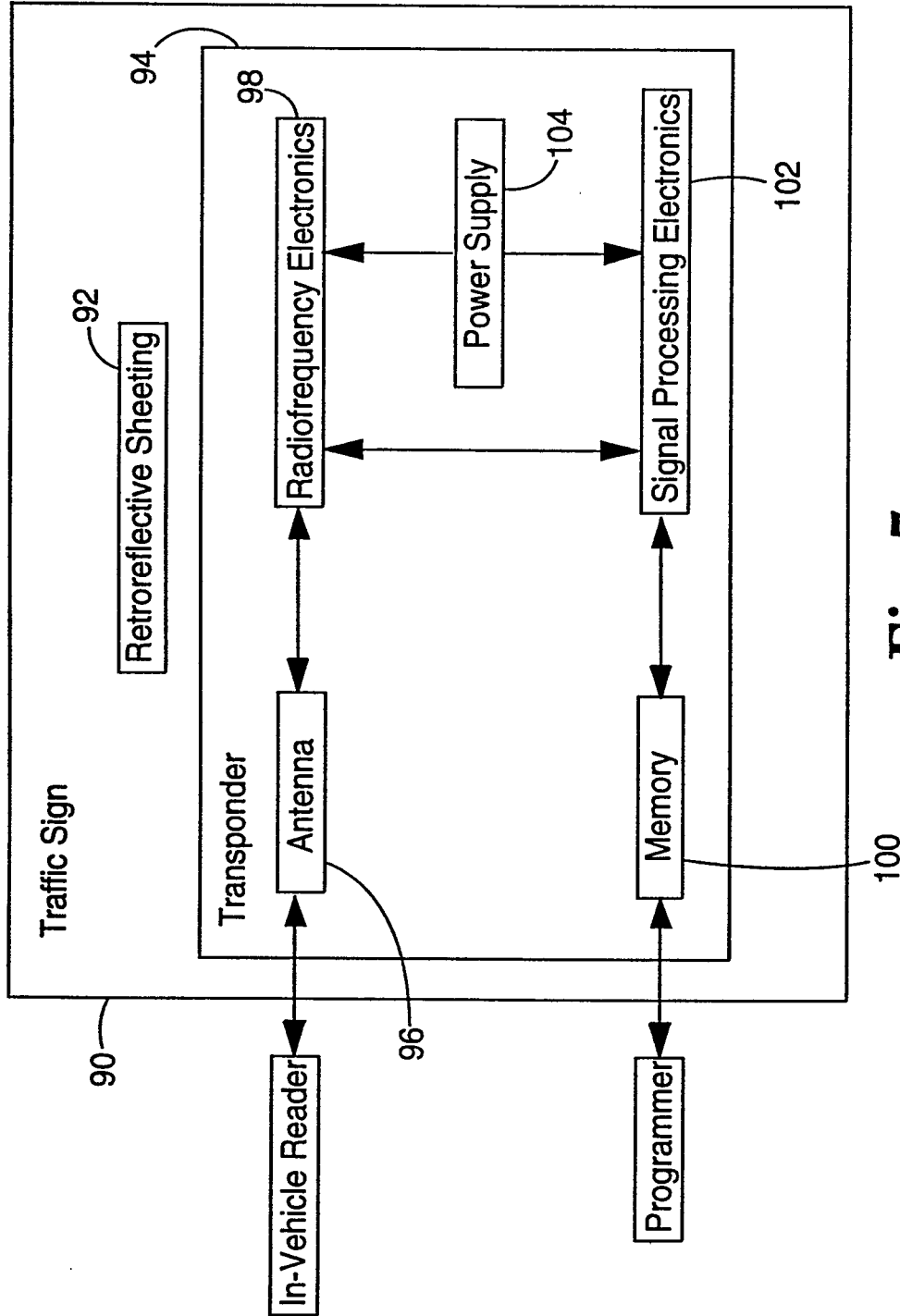

Fig. 7

5/14

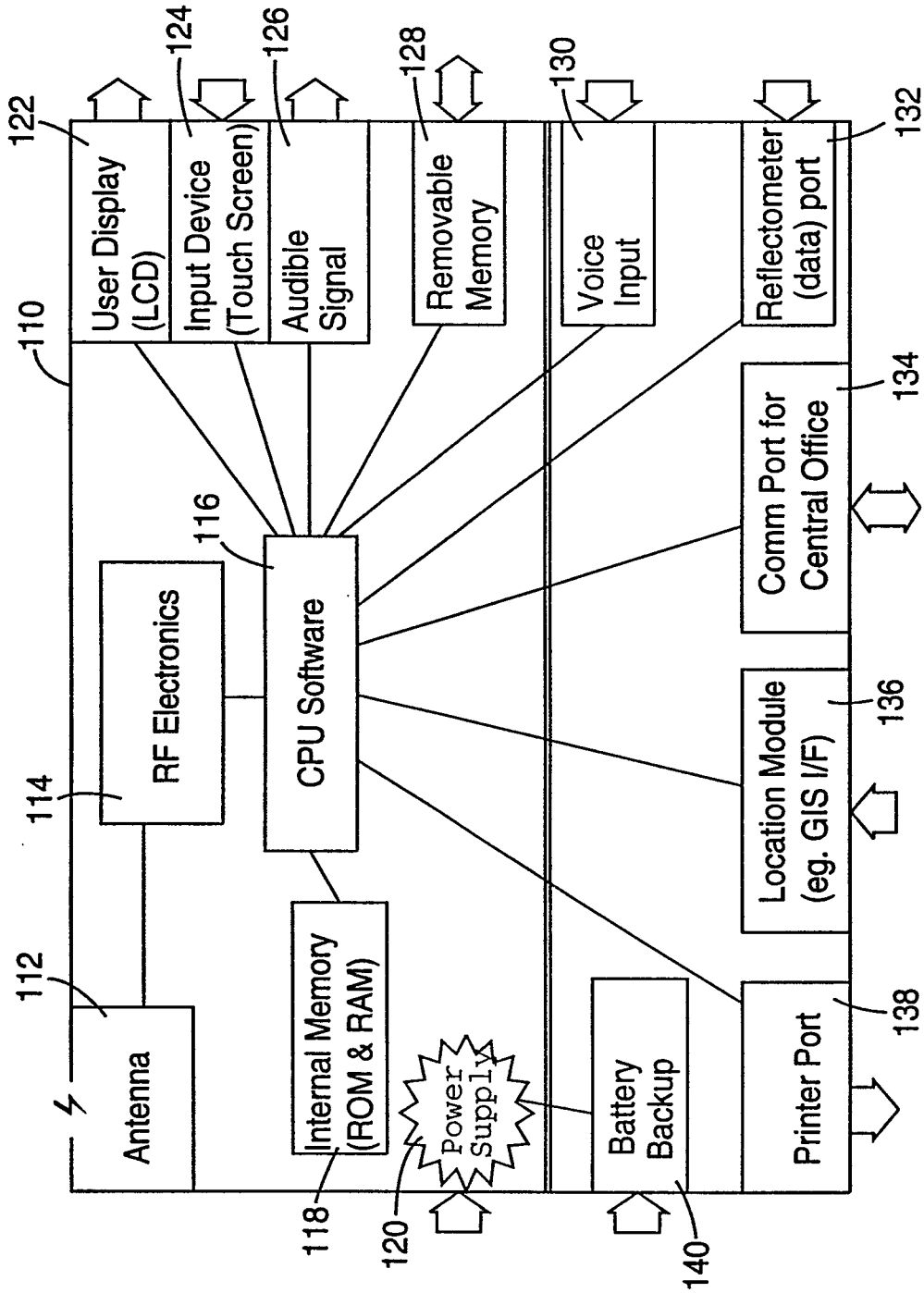
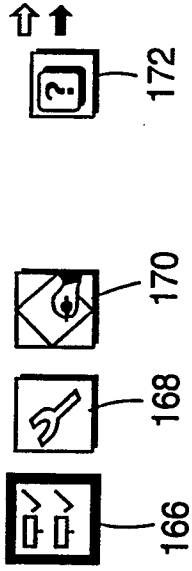
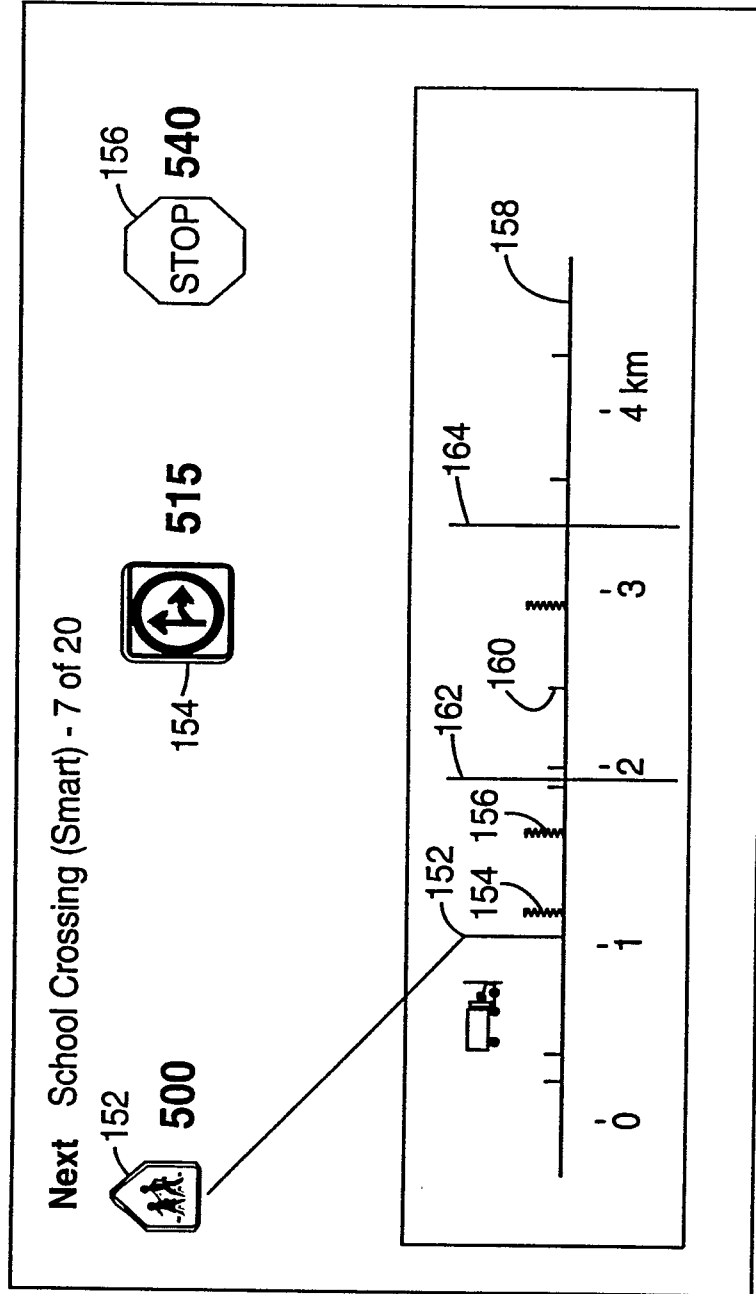

Fig. 8



**Inventory**

□ County J  
 From: Turner's Cross Road - East  
 To: Highway 100  
 5 miles, 20 signs



**Fig. 9a**

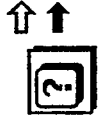

Inventory



County J  
From: Turner's Cross Road - East  
To: Highway 100  
5 miles, 20 signs

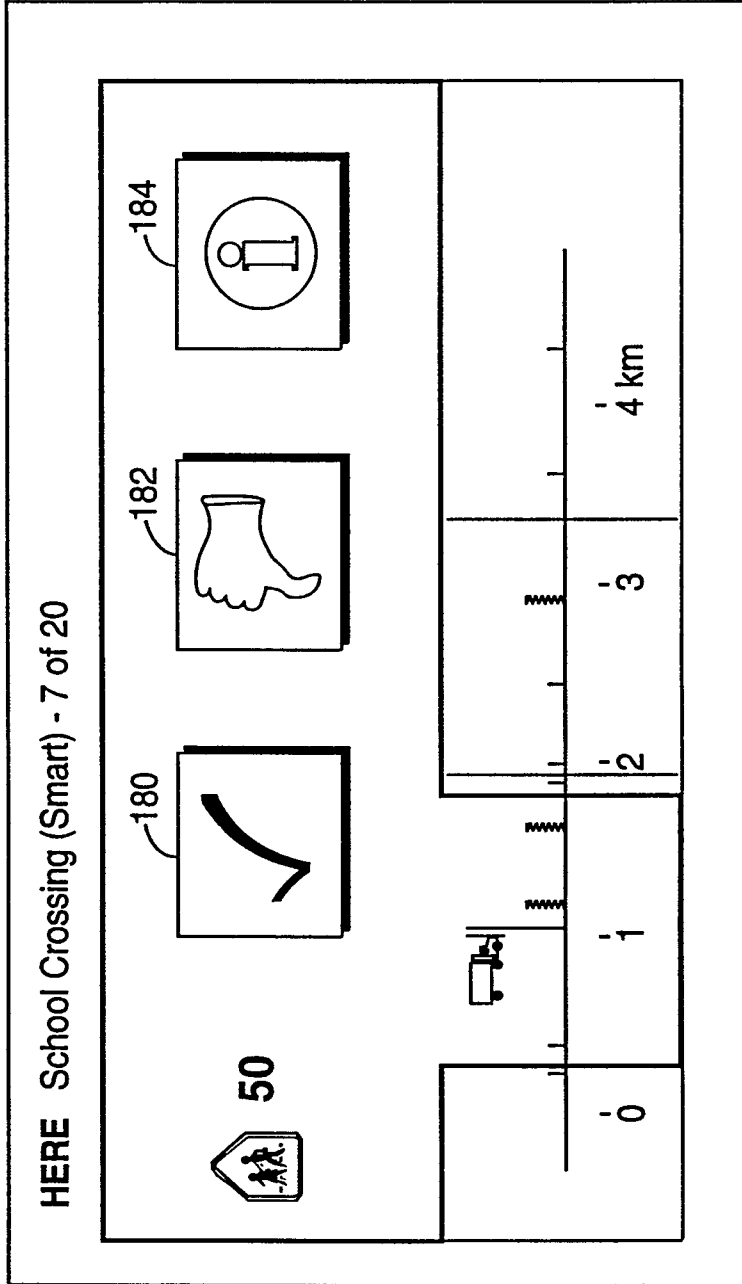
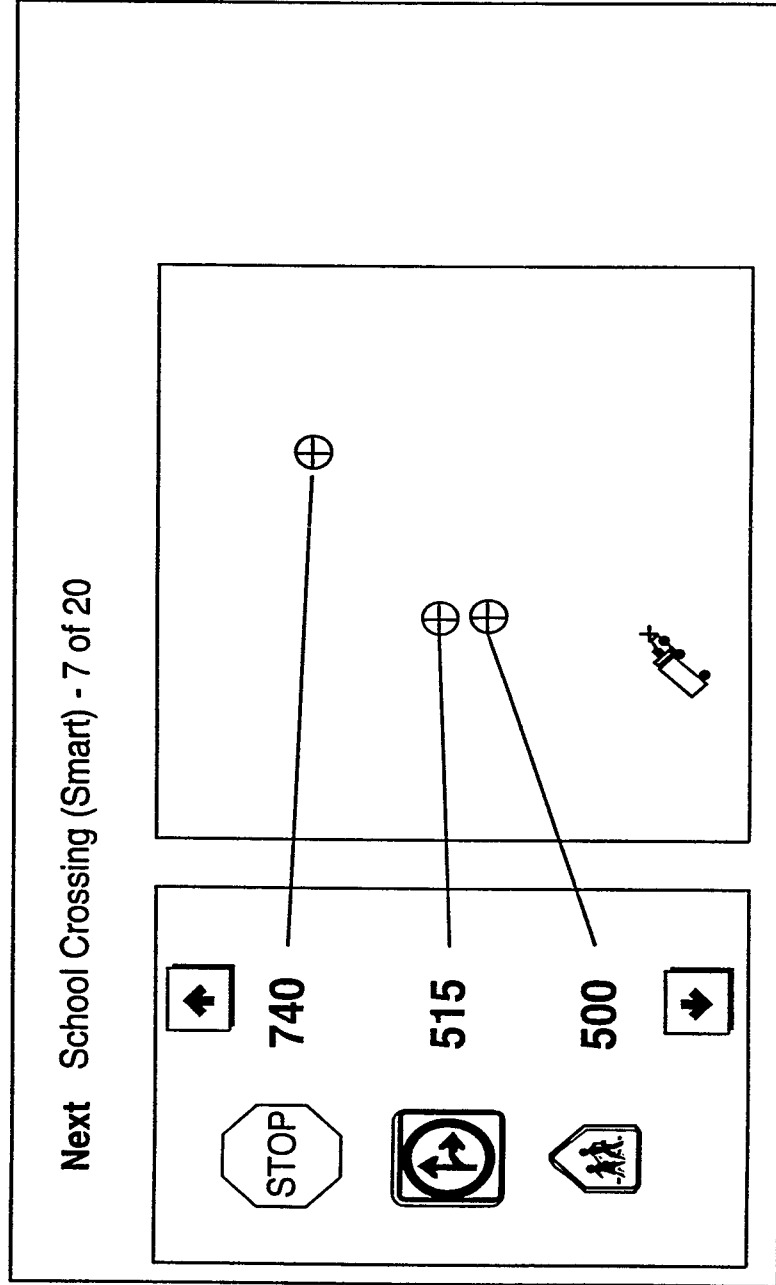

Fig. 9b



**Inventory**

- County J
- From: Turner's Cross Road - East
- To: Highway 100
- 5 miles, 20 signs

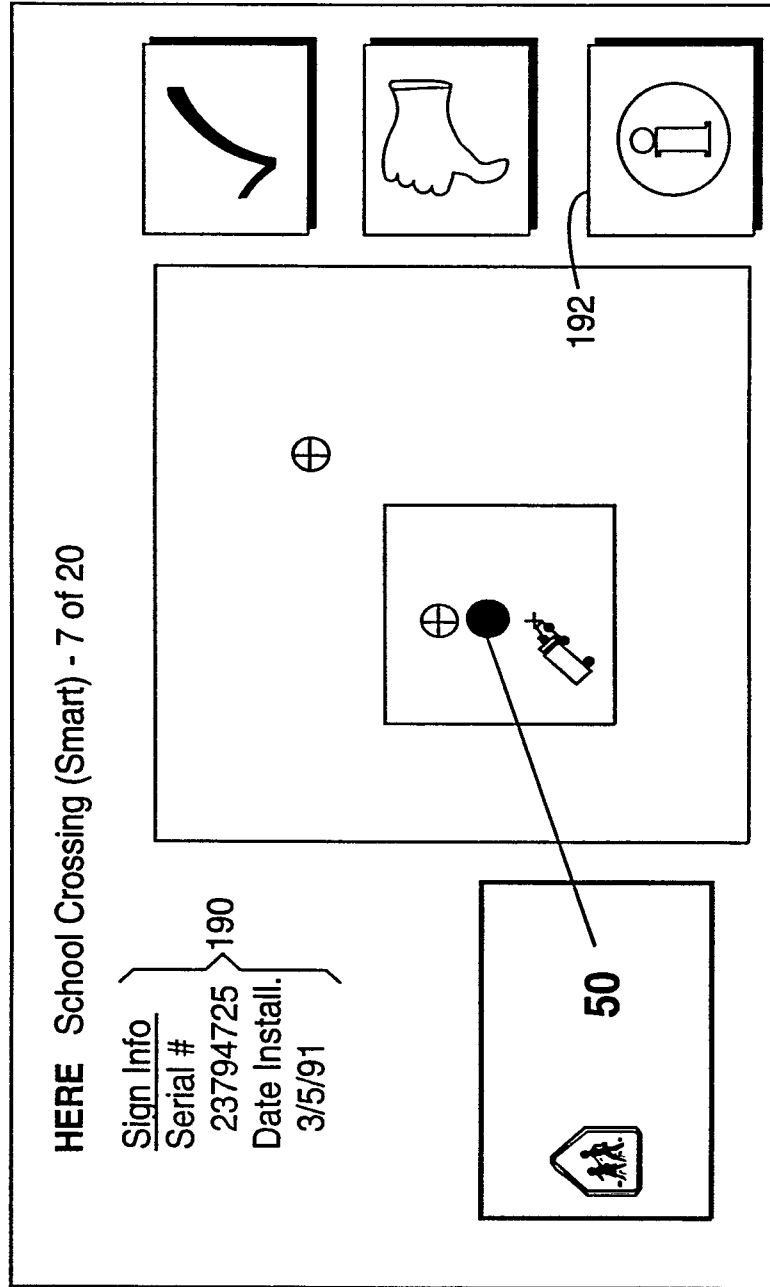

**Fig. 9c**



**Inventory**

County J  
 From: Turner's Cross Road - East  
 To: Highway 100  
 5 miles, 20 signs



**Fig. 9d**

10/14

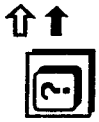

Inventory



County J  
From: Turner's Cross Road - East  
To: Highway 100  
5 miles, 20 signs

Signs Ahead

Mile	Sign Type	Smart?	Serial
0.75	Deer Crossing +		D186386
0.90	Speed Limit		S4792763
0.95	Hwy Junction +		J4783721
1.08	Stop		LJ987312

OK  Repair  No Data  See Info  Note

Fig. 9e

11/14

**Maintenance**

- Jones County
- Northwest Quadrant



Task List

County J W New Deer X

US 128 N Fix Spd Lmt

Applby E Rpl Hwy Xrng

County J S New Stop

US 128 North Mile 67.9 Fix Spd Lmt

Post rusted through -- replace

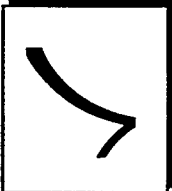
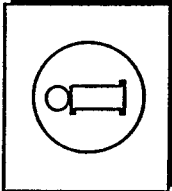
200

Fig. 10a

12/14

**Maintenance**

- Jones County
- Northwest Quadrant



US 128 North Mile 67.9 Fix Spd Lmt

Post rusted through -- replace

Speed Limit = 50 mph

Date installed = 4/5/92

Jurisdiction = Jones County

Type of Sign = Speed Limit

Date Repaired = 4/14/95

**Fig. 10b**

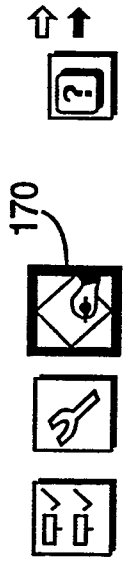

Roadway Notes

Location:

Arglebargle Drive; 35.873 / -86.526

Map

High	Low	
<input type="checkbox"/> !	<input type="checkbox"/>	Tree Trimming
<input type="checkbox"/> !	<input type="checkbox"/>	Grass Cutting
<input type="checkbox"/> !	<input type="checkbox"/>	Pothole
<input type="checkbox"/> !	<input type="checkbox"/>	Damaged Guardrail
<input type="checkbox"/> !	<input type="checkbox"/>	Reflector Post
<input type="checkbox"/> !	<input type="checkbox"/>	Repainting Needed
<input type="checkbox"/> !	<input type="checkbox"/>	Bridge Damage

210

212

208

Other

Cancel

OK

Fig. 11



