

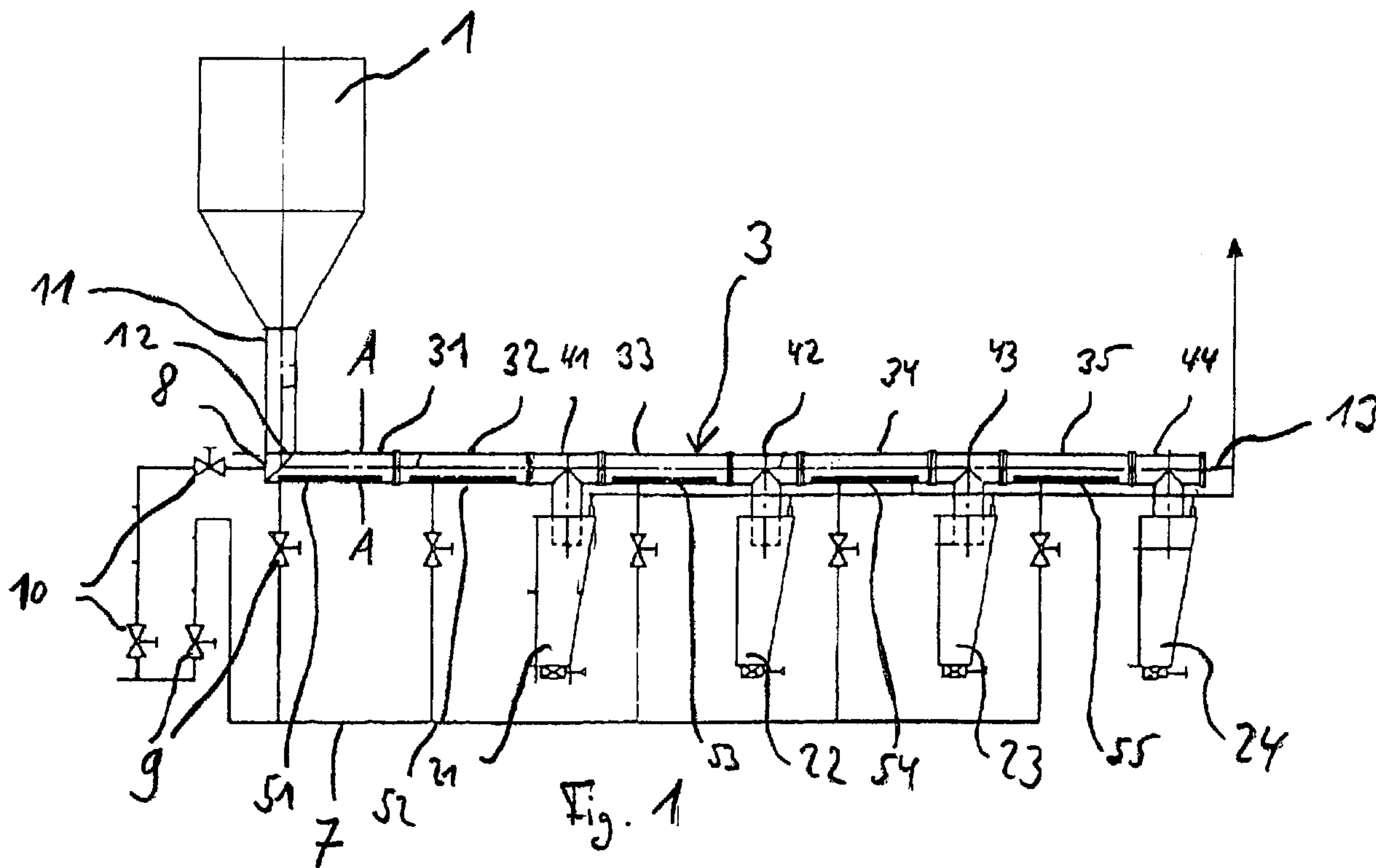

(86) Date de dépôt PCT/PCT Filing Date: 2007/06/04  
 (87) Date publication PCT/PCT Publication Date: 2008/12/11  
 (85) Entrée phase nationale/National Entry: 2009/12/04  
 (86) N° demande PCT/PCT Application No.: EP 2007/004957  
 (87) N° publication PCT/PCT Publication No.: 2008/148406

(51) Cl.Int./Int.Cl. *B65G 53/22* (2006.01),  
*B65G 53/16* (2006.01), *B65G 53/18* (2006.01)  
 (71) Demandeur/Applicant:  
 CLAUDIUS PETERS TECHNOLOGIES BMBH, DE  
 (72) Inventeurs/Inventors:  
 ALTMANN-RINCK, MICHAEL, DE;  
 HILGRAF, PETER, DE;  
 WOLF, ANDREAS, DE  
 (74) Agent: MARKS & CLERK

(54) Titre : DISPOSITIF DE DISTRIBUTION POUR PRODUIT FLUIDISABLE A TRANSPORTER  
 (54) Title: DISTRIBUTING DEVICE FOR A FLUIDIZABLE CONVEYED MATERIAL



(57) Abrégé/Abstract:

The distribution apparatus is designed to distribute fluidizable material to be conveyed (13) from a starting container (1) to a plurality of target containers (21, 22, 23, 24). The distribution apparatus comprises a conveyor pipe (3) which has an entry opening (12) for the material to be conveyed (13) and a plurality of exit openings (41, 42, 43, 44) for the material to be conveyed (13). Passage surfaces (51, 52, 53, 54, 55) are arranged in the conveyor pipe (3), through which surfaces a fluidization gas flow is introduced into the conveyor pipe (3). According to the invention, a propellant is supplied for the generation of a propellant flow along the conveyor pipe (3) in the conveying direction. The invention has the advantage that the material to be conveyed (13) is transported without

(57) **Abrégé(suite)/Abstract(continued):**

being influenced by the gradient of the conveyor pipe (3) and that the energy consumption is small. Another advantage of the invention is that the fluidization gas flow and the propellant flow are also suitable to transport remains of the material to be conveyed out of the conveyor pipe (3). The conveyor pipe (3) can thus be cleaned by means of the fluidization gas flow and the propellant flow.

(12) NACH DEM VERTRAG ÜBER DIE INTERNATIONALE ZUSAMMENARBEIT AUF DEM GEBIET DES  
PATENTWESENS (PCT) VERÖFFENTLICHTE INTERNATIONALE ANMELDUNG(19) Weltorganisation für geistiges Eigentum  
Internationales Büro(43) Internationales Veröffentlichungsdatum  
11. Dezember 2008 (11.12.2008)

PCT

(10) Internationale Veröffentlichungsnummer  
**WO 2008/148406 A1**

(51) Internationale Patentklassifikation:

**B65G 53/22** (2006.01) **B65G 53/16** (2006.01)**B65G 53/18** (2006.01)104a, 22149 Hamburg (DE). **WOLF, Andreas** [DE/DE];  
Berliner Ring 99, 21406 Melbeck (DE).

(21) Internationales Aktenzeichen: PCT/EP2007/004957

(74) **Anwalt: GLAWE DELFS MOLL**; Rothenbaumchaussee  
58, 20148 Hamburg (DE).

(22) Internationales Anmeldedatum:

4. Juni 2007 (04.06.2007)

(81) **Bestimmungsstaaten** (soweit nicht anders angegeben, für  
jede verfügbare nationale Schutzrechtsart): AE, AG, AL,  
AM, AT, AU, AZ, BA, BB, BG, BH, BR, BW, BY, BZ, CA,  
CH, CN, CO, CR, CU, CZ, DE, DK, DM, DO, DZ, EC, EE,  
EG, ES, FI, GB, GD, GE, GH, GM, GT, HN, HR, HU, ID,  
IL, IN, IS, JP, KE, KG, KM, KN, KP, KR, KZ, LA, LC, LK,  
LR, LS, LT, LU, LY, MA, MD, MG, MK, MN, MW, MX,  
MY, MZ, NA, NG, NI, NO, NZ, OM, PG, PH, PL, PT, RO,  
RS, RU, SC, SD, SE, SG, SK, SL, SM, SV, SY, TJ, TM,  
TN, TR, TT, TZ, UA, UG, US, UZ, VC, VN, ZA, ZM, ZW.

(25) Einreichungssprache:

Deutsch

(26) Veröffentlichungssprache:

Deutsch

(71) **Anmelder** (für alle Bestimmungsstaaten mit Ausnahme von  
US): **CLAUDIUS PETERS TECHNOLOGIES GMBH**  
[DE/DE]; Schanzenstrasse 40, 21614 Buxtehude (DE).(72) **Erfinder; und**(75) **Erfinder/Anmelder** (nur für US): **ALTMANN-RINCK,**  
**Michael** [DE/DE]; Floriastrasse 15a, 21614 Buxtehude  
(DE). **HILGRAF, Peter** [DE/DE]; Rahlstedter Strasse(84) **Bestimmungsstaaten** (soweit nicht anders angegeben, für  
jede verfügbare regionale Schutzrechtsart): ARIPO (BW,  
[Fortsetzung auf der nächsten Seite]

(54) Title: DISTRIBUTION APPARATUS FOR FLUIDIZABLE MATERIAL TO BE CONVEYED

(54) Bezeichnung: VERTEILVORRICHTUNG FÜR EIN FLUIDISIERBARE FÖRDERGUT

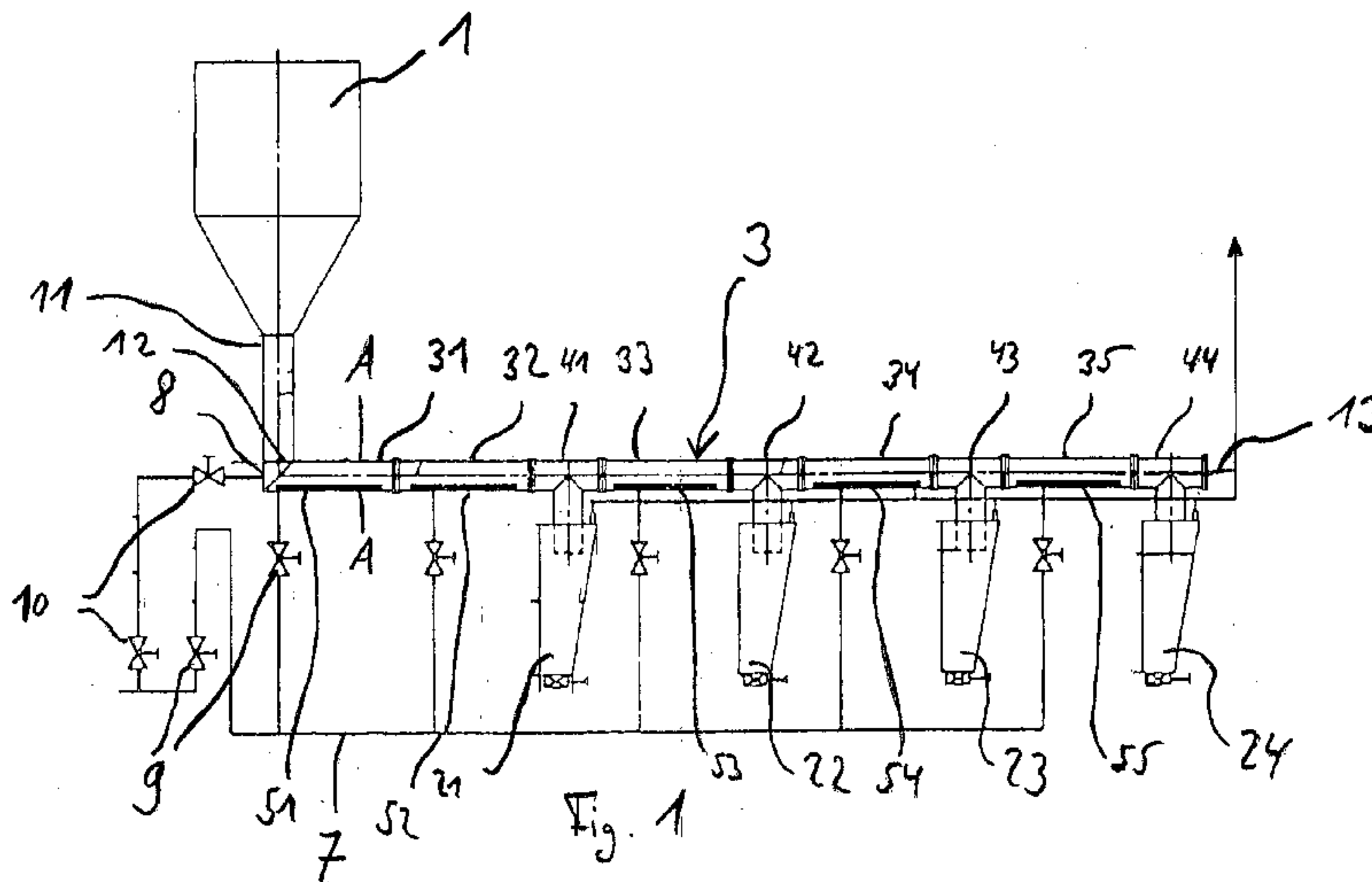
(57) **Abstract:** The distribution apparatus is designed to distribute fluidizable material to be conveyed (13) from a starting container (1) to a plurality of target containers (21, 22, 23, 24). The distribution apparatus comprises a conveyor pipe (3) which has an entry opening (12) for the material to be conveyed (13) and a plurality of exit openings (41, 42, 43, 44) for the material to be conveyed (13). Passage surfaces (51, 52, 53, 54, 55) are arranged in the conveyor pipe (3), through which surfaces a fluidization gas flow is introduced into the conveyor pipe (3). According to the invention, a propellant is supplied for the generation of a propellant flow along the conveyor pipe (3) in the conveying direction. The invention has the advantage that the material to be conveyed (13) is transported without being influenced by the gradient of the conveyor pipe (3) and that the energy consumption is small. Another advantage of the invention is that the fluidization gas flow and the propellant flow are also suitable to transport remains of the material to be conveyed out of the conveyor pipe (3). The conveyor pipe (3) can thus be cleaned by means of the fluidization gas flow and the propellant flow.(57) **Zusammenfassung:** Die Verteilvorrichtung ist dazu ausgelegt, ein fluidisierbares Fördergut (13) von einem Ausgangsbehälter (1) auf einer Mehrzahl von Zielbehältern (21, 22, 23, 24) zu verteilen. Die Verteilvorrichtung umfasst ein Förderrohr (3), das eine Zutrittsöffnung (12) für das Fördergut (13) und eine Mehrzahl

[Fortsetzung auf der nächsten Seite]

WO 2008/148406 A1

**WO 2008/148406 A1**

GH, GM, KE, LS, MW, MZ, NA, SD, SL, SZ, TZ, UG, ZM, ZW), eurasisches (AM, AZ, BY, KG, KZ, MD, RU, TJ, TM), europäisches (AT, BE, BG, CH, CY, CZ, DE, DK, EE, ES, FI, FR, GB, GR, HU, IE, IS, IT, LT, LU, LV, MC, MT, NL, PL, PT, RO, SE, SI, SK, TR), OAPI (BF, BJ, CF, CG, CI, CM, GA, GN, GQ, GW, ML, MR, NE, SN, TD, TG).

- *hinsichtlich der Berechtigung des Anmelders, ein Patent zu beantragen und zu erhalten (Regel 4.17 Ziffer ii)*
- *Erfindererklärung (Regel 4.17 Ziffer iv)*

**Veröffentlicht:**

- *mit internationalem Recherchenbericht*

**Erklärungen gemäß Regel 4.17:**

- *hinsichtlich der Identität des Erfinders (Regel 4.17 Ziffer i)*

---

von Austrittsöffnungen (41, 42, 43, 44) für das Fördergut (13) aufweist. In dem Förderrohr (3) sind Durchtrittsflächen (51, 52, 53, 54, 55) angeordnet, durch die ein Fluidisiergasstrom in das Förderrohr (3) eingeleitet wird. Erfindungsgemäß ist eine Treibgas Zuführung (8) zum Erzeugen eines Treibgasstroms entlang der Förderrichtung des Förderrohrs (3) vorgesehen. Die Erfindung hat den Vorteil, dass das Fördergut (13) unabhängig von einem Gefälle des Förderrohrs (3) transportiert wird und dass der Energieverbrauch gering ist. Ein weiterer Vorteil der Erfindung besteht darin, dass der Fluidisiergasstrom und der Treibgasstrom auch dazu geeignet sind, Fördergutreste aus dem Förderrohr (3) heraus zutransportieren. Das Förderrohr (3) kann also mit Hilfe des Fluidisiergasstroms und des Treibgasstroms gereinigt werden.

**Distributing device for a fluidizable conveyed material**

The invention relates to a distributing device for  
5 distributing a fluidizable conveyed material from a  
starting container to a plurality of destination  
containers. The distributing device comprises a  
conveying pipe having an intake opening for the  
conveyed material and a plurality of discharge openings  
10 for the conveyed material. In the conveying pipe there  
are arranged pass-through surfaces, through which a  
fluidizing gas stream is introduced into the conveying  
pipe.

15 Distributing devices of this type can be used, for  
example, in the production of aluminium. The alumina  
which is necessary for the aluminium production must be  
fed from a central storage container to the individual  
electrolytic cells. According to the size of the  
20 production plant, the alumina supply system is divided  
into several levels, the destination containers of the  
higher levels respectively forming the starting  
containers of the following level. The distributing  
device according to the invention is particularly  
25 suitable for the last level, at which the alumina is  
distributed from an intermediate container to the  
receiving containers of the electrolytic cells.

A distributing device of this type is known, in which  
30 the fluidized conveyed material moves along the  
conveying pipe under the influence of gravity, WO  
02/074670 A1. A drawback of this distributing device  
consists in the fact that the conveying pipe must have  
a constant gradient over the whole of its length. In  
35 many cases there are, however, spatial pre-  
specifications for the course of the conveying pipe,  
which make it difficult to meet the need for a constant  
gradient. This applies, in particular, where existing

- 2 -

plants are to be retrofitted with a new distributing device.

So-called pneumatic distributing devices are also  
5 known. In these distributing devices, the conveying  
pipe has a propellant gas stream passed through it,  
which is sufficiently fast that the conveyed material  
in the conveying pipe is taken up and entrained by the  
gas stream. In order for the conveyed material to be  
10 entrained by the propellant gas stream, the velocity of  
the propellant gas velocity must be at least 6 m/s to 7  
m/s. Although such a distributing device is versatile  
in its use and it is possible to transport the conveyed  
material counter to the force of gravity, the energy  
15 consumption is very high.

The object of the invention is to provide a  
distributing device of the type stated in the  
introduction, which has low energy consumption and is  
20 versatile in its use. The object is achieved by virtue  
of the features of claim 1. According to this, the  
distributing device comprises a propellant gas feed for  
generating a propellant gas stream along the direction  
of conveyance of the conveying pipe. Advantageous  
25 embodiments can be found in the sub-claims.

To begin with, a few terms are explained. By  
fluidization is meant a process by which a material  
existing in granular form is transformed into a state  
30 in which it behaves similar to a liquid. In the  
original state, the particles of the granular material  
lie one on top of the other under the influence of  
gravity. The friction between the particles is so great  
that a considerable force is necessary to move them  
35 relative to one another. For the fluidization, a gas  
stream is passed from below through the granular  
material, so that the gas stream counters the influence  
of gravity upon the particles. Given a suitably chosen  
fluidizing gas stream, the friction between the

- 3 -

particles is so small that the granular material assumes the properties of a liquid. The granular material thus has the property, for example, of flowing along a gradient.

5

As fluidizable is termed any material which can be transformed into this state by a suitable fluidizing gas stream.

10 The pass-through surfaces arranged in the conveying pipe have the function of introducing the fluidizing gas stream into the conveyed material such that the conveyed material assumes the fluidized state. The pass-through surfaces are thus arranged beneath the  
15 conveyed material, so that the fluidizing gas stream can act on the conveyed material over a large area.

The conveyed material can be distributed from a starting container to a large number of destination  
20 containers. Plants are possible in which several hundred destination containers are assigned to one starting container. The destination containers, for their part, can in turn be starting containers for a subordinate distributing device. In this way, several  
25 levels of distributing devices can be arranged hierarchically one behind the other.

According to the invention, a propellant gas feed is provided, which is designed to generate a propellant  
30 gas stream along the direction of conveyance of the conveying pipe. The propellant gas feed is preferably arranged at the start of the conveying pipe, i.e. in front of the intake opening. The generated propellant gas stream is of such a size that the fluidized  
35 conveyed material moves through the conveying pipe in the direction of conveyance. At the end of the conveying pipe, i.e. behind the last discharge opening in the direction of conveyance, a waste air device can

- 4 -

be arranged, through which the propellant gas stream can be evacuated.

When the propellant gas stream enters into the fluidized conveyed material, the propellant gas stream mixes with the fluidizing gas stream. The fluidizing gas stream is deflected in the direction of conveyance, so that the propellant gas stream together with the fluidizing gas stream, as a combined gas stream, support the transport of the conveyed material along the conveying pipe.

The fact that the fluidized conveyed material is moved by the propellant gas stream or the combined gas stream in the direction of conveyance means that the distributing device according to the invention is independent of gravity. There is thus a greater freedom of choice with regard to the conveying track. The propellant gas stream has merely to be dimensioned such that the fluidized conveyed material, which is subjected to low internal friction, is conveyed. Even though the conveying pipe is fed, apart from the propellant gas stream, also a fluidizing gas stream, the gas consumption is considerably less than with a purely pneumatic distributing device.

Since the distributing device is independent of gravity, the conveyed material can also be transported when only a small amount of conveyed material is present in the conveying pipe. It is also possible to transport remnants of conveyed material out of the conveying pipe. The propellant gas stream can be used to clean the conveying pipe. According to the invention, this is possible, in particular, even in the case of horizontal and rising arrangement of the conveying pipe.

Since the propellant gas stream and the combined gas stream are forced along the conveying pipe, it is

- 5 -

possible to deflect the small-radius conveying pipe without the transport thereby being stopped. A conveyed material which is moved solely under the influence of gravity stalls at deflections of this type. The  
5 distributing device according to the invention thus allows the path of conveyance to be designed more freely.

It has been shown that a transport of the conveyed  
10 material along the conveying pipe is also possible when the pass-through surfaces do not extend over the whole of the length of the conveying pipe. As a result of the interaction of the fluidizing gas stream with the propellant gas stream, the transport is instead  
15 maintained, even when the conveying pipe has portions in which no fluidizing gas is supplied. Within the scope of the invention, it is therefore possible to arrange the discharge openings in the floor of the conveying pipe. Preferably, the discharge openings are  
20 arranged in those portions of the conveying pipe in which no pass-through surfaces are arranged. It has been shown that the combined gas stream of fluidizing gas and carrier gas transports the conveyed material such that a part of the conveyed material falls  
25 downwards through the discharge opening, whilst a part of the conveyed material is transported over the discharge opening along the conveying pipe. The fact that at each discharge opening a part of the conveyed material falls downwards, whilst a part is transported  
30 onward along the conveying pipe, results in the destination containers filling with conveyed material at different rates. The destination containers arranged at the start of the conveying pipe are filled earlier than the destination containers arranged at the end of  
35 the conveying pipe. This can be countered, for example, by the discharge openings having different cross sections or by the discharge openings being provided with valves. Generally, however, the different filling speed of the destination containers is tolerated. Once

- 6 -

the first destination container is fully filled, no conveyed material can any longer fall into this destination container and the whole of the conveyed material is transported over this discharge opening  
5 along the conveying pipe. The distributing device is operated until such time as the last destination container is filled, and is then stopped. In order to determine the time to stop the distributing device, a fill level sensor can be provided for indicating the  
10 fill state of the last destination container. It is likewise possible to arrange fill level sensors in all destination containers.

That a part of the conveyed material falls through the  
15 discharge openings, whilst a part is transported over the discharge opening, applies even if the discharge opening extends over the entire width or almost the entire width of the conveying pipe. The discharge opening can thus have a cross section of the same size  
20 or almost the same size as the conveying pipe. It is considered advantageous if the cross-sectional area of the discharge opening is no more than 20%, preferably no more than 10%, further preferably no more than 5% smaller than the cross-sectional area of the conveying  
25 pipe.

Since the transport mechanism is independent of gravity, the conveying pipe can be configured such that it has a portion which rises in the direction of  
30 conveyance. The rise can be inclined by 10°, preferably by 20°, further preferably by 30°, in relation to the horizontal.

The distributing device according to the invention can  
35 be constituted such that it comprises the destination containers in which the conveyed material discharged through the discharge openings is collected. If the conveying pipe has a rise, then a second destination container situated further to the rear in the direction

- 7 -

- of conveyance can be arranged higher than a destination container situated further forward. Between the first and the second destination container, the conveyed material is conveyed counter to gravity. If the destination containers are arranged beneath the discharge openings, the conveyed material collects in the destination containers purely under the influence of gravity.
- 10 For an effective transport of the conveyed material, it must be ensured that the propellant gas stream and the combined gas stream move along the track predefined by the conveying pipe. The gas stream should not be able en route to escape from the conveying pipe. The destination containers are therefore preferably sealingly connected to the conveying pipe, so that an escape of the gas stream through the destination containers is not possible.
- 20 Furthermore, the starting container can also be regarded as a component part of the distributing device. The starting container is preferably arranged above the intake opening of the conveying pipe, so that the conveyed material moves into the conveying pipe purely under the influence of gravity. It is possible that, at the transition from the starting container to the intake opening, a lock chamber is provided.
- 30 Firstly, the lock chamber can ensure that the gas stream cannot escape from the conveying pipe out through the intake opening and the starting container. Secondly, the lock chamber can ensure that only measured-off quantities of conveyed material can enter into the conveying pipe.
- 35 Such a lock chamber is not, however, necessary; it is instead possible within the scope of the invention for the transition from the starting container through the intake opening into the conveying pipe to be freely

- 8 -

traversable for the conveyed material. Such quantity of conveyed material then passes out of the starting container into the conveying pipe that the conveying pipe, in the region below the intake opening, is filled  
5 with the conveyed material. The conveyed material is fluidized by the fluidizing gas stream and carried away from the region below the intake opening by the propellant gas stream. A freely traversable opening is advantageous, because the conveying pipe is then free  
10 from mechanically moved components.

Through a freely traversable opening, a gas stream can also, in principle, escape. A resistance is offered against the gas stream, however, by the fact that it  
15 must penetrate the conveyed material arranged in front of the intake opening. This resistance is the greater, the longer the path is through the conveyed material and the smaller the area is over which the gas stream can be distributed within the conveyed material.  
20 Preferably, so much conveyed material is arranged in front of the intake opening that the intake opening is sealed off. An, in this sense, adequate seal is proclaimed if only a small part of less than 10% of the gas stream in the conveying pipe is able to escape  
25 through the intake opening.

The starting container can be arranged in the immediate vicinity of the intake opening. The sealing of the gas stream is then taken care of by the conveyed material.  
30 It is advantageous if a connecting pipe filled with conveyed material is arranged between the starting container and the intake opening. The connecting pipe has a smaller cross-sectional area than the starting container, so that a greater resistance is offered  
35 against the gas stream. The connecting pipe can have the same cross-sectional area as the conveying pipe. For an effective seal, the connecting pipe has a length between 0.8 m and 3 m, preferably between 1.3 m and 2 m.

A transport of the conveyed material along the conveying pipe only takes place when a pressure difference exists between the start of the conveying pipe and the end of the conveying pipe. It is desirable to operate the distributing device with a smallest possible pressure difference. The sealing of the starting container and of the destination containers enables the distributing device to be operated with a pressure difference between the start of the conveying pipe and the end of the conveying pipe of no more than 0.2 bar, preferably no more than 0.1 bar.

The cross section of the conveying pipe can have an optional shape, for example square or rectangular. In a preferred embodiment, the conveying pipe is round in cross section. The pass-through surfaces are arranged in the lower half of the pipe such that they divide the pipe into two segments in cross section. Through the lower segment, the fluidizing gas is introduced into the conveying pipe and distributed amongst the pass-through surfaces. The fluidizing gas can enter over a large area through the pass-through openings into the upper segment of the conveying pipe and can fluidize the conveyed material in this segment. The conveyed material is transported through the upper segment along the conveying pipe.

The pass-through surfaces separating the two segments can be of flat configuration, which promotes the even distribution of the fluidizing gas. Furthermore, the pass-through surfaces are configured such that they offer as little resistance as possible to the fluidizing gas, but such that the conveyed material can nevertheless not fall through the pass-through surfaces.

Since, in the distributing device according to the invention, the fluidizing gas moves together with the

- 10 -

conveyed material through the conveying pipe, the diameter of the conveying pipe can be smaller than in known distributing devices. In these, it is namely always assumed that, above the space necessary for the  
5 conveyed material, further space must be present, through which the fluidizing gas can be evacuated.

In an advantageous embodiment, the propellant gas feed is designed such that the propellant gas stream through  
10 the conveying pipe has a velocity between 0.5 m/s and 1.5 m/s, preferably a velocity between 0.7 m/s and 1.0 m/s. The data regarding the propellant gas stream relate to that portion of the conveying pipe in which the propellant gas is not yet mixed with the fluidizing  
15 gas. The conveyed material moves through the conveying pipe with a velocity which is slightly less than the velocity of the propellant gas stream. At this propellant gas velocity, up to 12 t/h of conveyed material can be transported in a conveying pipe of 10  
20 cm diameter.

The fluidizing gas stream which is necessary to fluidize the conveyed material is generally quoted as the specific fluidizing gas stream related to the pass-  
25 through surface. Within the scope of the invention, this fluidizing gas stream can range between 0.8  $\text{m}^3/(\text{m}^2 \cdot \text{min})$  and 1.8  $\text{m}^3/(\text{m}^2 \cdot \text{min})$ , preferably between 1.3  $\text{m}^3/(\text{m}^2 \cdot \text{min})$  and 1.6  $\text{m}^3/(\text{m}^2 \cdot \text{min})$ . The propellant gas quantity fed to the conveying pipe is independent of  
30 the actual length of the conveying pipe. The fluidizing gas quantity, by contrast, becomes larger the greater the length of the conveying pipe, since in a longer conveying pipe more pass-through surfaces are necessary.

35

The invention is described below, by way of example, on the basis of an advantageous embodiment with reference to the appended drawings, wherein:

- 11 -

Fig. 1: shows a schematic representation of a distributing device according to the invention;

5 Fig. 2: shows a cross section through Fig. 1 along the line A-A;

Fig. 3: shows an enlarged detail from Fig. 1.

10 An inventive distributing device in Fig. 1 is designed to distribute a conveyed material from a starting container 1 to a plurality of destination containers 21, 22, 23, 24. In the illustrative embodiment, only four destination containers 21, 22, 23, 24 are shown,  
15 whereas in real distributing devices several hundred destination containers can be present. The connection between the starting container 1 and the destination containers 21, 22, 23, 24 creates a conveying pipe 3. The conveying pipe 3 is made up of a plurality of pipe  
20 segments 31, 32, 33, 34, 35. The conveying pipe 3 additionally comprises discharge openings 41, 42, 43, 44 arranged in T-pieces, each discharge opening 41, 42, 43, 44 being arranged above a destination container 21, 22, 23, 24. Under the influence of gravity, conveyed  
25 material can fall out of the conveying pipe 3 through the discharge openings 41, 42, 43, 44 into the destination containers 21, 22, 23, 24.

In the lower half of the pipe segments 31, 32, 33, 34,  
30 35, pass-through openings 51, 52, 53, 54, 55 are arranged. In the region of the discharge openings 41, 42, 43, 44, the conveying pipe 3 is free from pass-through surfaces 51, 52, 53, 54, 55. As Fig. 2 shows from the example of the pass-through surface 51, the  
35 pass-through surfaces 51, 52, 53, 54, 55 divide the pipe 3 into an upper segment 61 and a lower segment 62. To the lower segment 62, fluidizing gas is fed through a line 7. The fluidizing gas is distributed in the pipe segment 62 below the pass-through surface 51 and

- 12 -

generates a fluidizing gas stream, which enters through the pass-through surface 51 into the pipe segment 61. Conveyed material present in the pipe segment 61 and resting on the pass-through surface 51 is fluidized by the fluidizing gas stream, which acts from below.

At the start of the conveying pipe 3, a propellant gas feed 8 is arranged, by which a propellant gas stream is generated along the direction of conveyance of the conveying pipe 3. The transport of the fluidized conveyed material is set in train by the propellant gas stream and the fluidizing gas stream is deflected, so that the conveyed material is transported by a combined gas stream along the conveying pipe 3. A part of the conveyed material falls through the discharge openings 41, 42, 43, 44 into the destination containers 21, 22, 23, 24, whilst a part of the conveyed material passes over the discharge openings 41, 42, 43, 44. The destination containers arranged at the start of the conveying pipe 3 thereby fill faster than the destination containers arranged at the end of the conveying pipe 3. Once all destination containers 21, 22, 23, 24 are filled, the conveyance of the conveyed material can be suspended, the propellant gas stream and the fluidizing gas stream can thus be switched off. The switching on and off of the fluidizing gas stream and the propellant gas stream is served by valves 9, 10.

In order for the propellant gas stream and the combined gas stream to effect a transport of the conveyed material, the gas streams must move along the conveying pipe 3. In order to prevent the gas streams from being able to escape from the conveying pipe 3 in another direction, the destination containers 21, 22, 23, 24 are therefore sealingly connected to the discharge openings 41, 42, 43, 44.

- 13 -

The starting container 1 is connected by a connecting pipe 11 to the intake opening 12 of the conveying pipe 3. The connecting pipe 11 and the intake opening 12 are freely traversable, so that the conveyed material can  
5 fall out of the starting container 1 under the influence of gravity into the conveying pipe 3. When the distributing device is out of action, a build-up of non-fluidized conveyed material 13 forms, as shown in Fig. 3, in that region of the conveying pipe 3 which is  
10 arranged below the intake opening 12. By switching on the fluidizing gas stream, that part of the conveyed material which is present in the conveying pipe 3 is fluidized. The fluidized conveyed material is transported by the propellant gas stream along the  
15 conveying pipe 3.

The column of conveyed material in the connecting pipe 11 seals off the conveying pipe 3 in the direction of the starting container 1. The propellant gas stream and  
20 the fluidizing gas stream cannot escape through the starting container 1, but are forced along the conveying pipe 3. At the end of the conveying pipe 3, the combined gas streams of fluidizing gas and propellant gas are evacuated by a waste air device 13.

25 The destination containers 21, 22, 23, 24 can, for their part, be starting containers for destination containers of a subordinate level. In this way, the distributing devices can be combined over several  
30 hierarchically arranged levels.

**Patent claims**

1. A distributing device for distributing a  
5 fluidizable conveyed material from a starting container  
(1) to a plurality of destination containers (21, 22,  
23, 24), comprising a conveying pipe (3) having an  
intake opening (12) for the conveyed material and a  
plurality of discharge openings (41, 42, 43, 44) for  
10 the conveyed material, and comprising pass-through  
surfaces (51, 52, 53, 54, 55), arranged in the  
conveying pipe (3), for a fluidizing gas stream,  
wherein a propellant gas feed (8) is provided, for  
generating a propellant gas stream along the direction  
15 of conveyance of the conveying pipe (3).
2. The distributing device as claimed in claim 1,  
wherein the fluidizing gas stream and the propellant  
gas stream are dimensioned such that a transport of  
20 conveyed material remnants out of the conveying pipe  
(3) is possible.
3. The distributing device as claimed in claim 1  
or 2, wherein the discharge openings (41, 42, 43, 44)  
25 are arranged on the floor of the conveying pipe (3).
4. The distributing device as claimed in one of  
claims 1 to 3, wherein the cross-sectional area of at  
least one discharge opening (41, 42, 43, 44) is no more  
30 than 20%, preferably no more than 10%, further  
preferably no more than 5% smaller than the cross-  
sectional area of the conveying pipe (3).
5. The distributing device as claimed in one of  
35 claims 1 to 4, wherein the conveying pipe (3) has a  
portion which rises in the direction of conveyance.
6. The distributing device as claimed in one of  
claims 1 to 5, which comprises destination containers

- 15 -

(51, 52, 53, 54), and wherein a second destination container is arranged behind a first destination container in the direction of conveyance of the conveying pipe (3), and wherein the second destination  
5 container is arranged higher than the first destination container.

7. The distributing device as claimed in one of claims 1 to 6, wherein the destination containers (51,  
10 52, 53, 54) are sealingly connected to the conveying pipe (3).

8. The distributing device as claimed in one of claims 1 to 7, which comprises a starting container  
15 (1), and wherein the starting container (1) is arranged above the intake opening (12).

9. The distributing device as claimed in claim 8, wherein the intake opening (12) is freely traversable  
20 for conveyed material from the starting container (1).

10. The distributing device as claimed in claim 9, wherein in front of the intake opening (12) conveyed material is arranged in such a way that the intake  
25 opening (12) is sealed off.

11. The distributing device as claimed in claim 10, wherein a connecting pipe (11) is arranged between the starting container (1) and the intake opening (12).  
30

12. The distributing device as claimed in claim 11, wherein the connecting pipe (11) has a length between 0.8 m and 3 m, preferably between 1.3 m and 2 m.

35 13. The distributing device as claimed in one of claims 1 to 12, wherein the pass-through surfaces (51, 52, 53, 54, 55) are flat.

- 16 -

14. The distributing device as claimed in one of claims 1 to 13, wherein the propellant gas quantity supplied by the propellant gas feed (8) is dimensioned such that the propellant gas stream through the conveying pipe has a velocity between 0.5 m/s and 1.5 m/s, preferably a velocity between 0.7 m/s and 1.0 m/s.

15. The distributing device as claimed in one of claims 1 to 14, wherein the specific fluidizing gas stream related to the pass-through surface ranges between  $0.8 \text{ m}^3/(\text{m}^2 \cdot \text{min})$  and  $1.8 \text{ m}^3/(\text{m}^2 \cdot \text{min})$ , preferably between  $1.3 \text{ m}^3/(\text{m}^2 \cdot \text{min})$  and  $1.6 \text{ m}^3/(\text{m}^2 \cdot \text{min})$ .

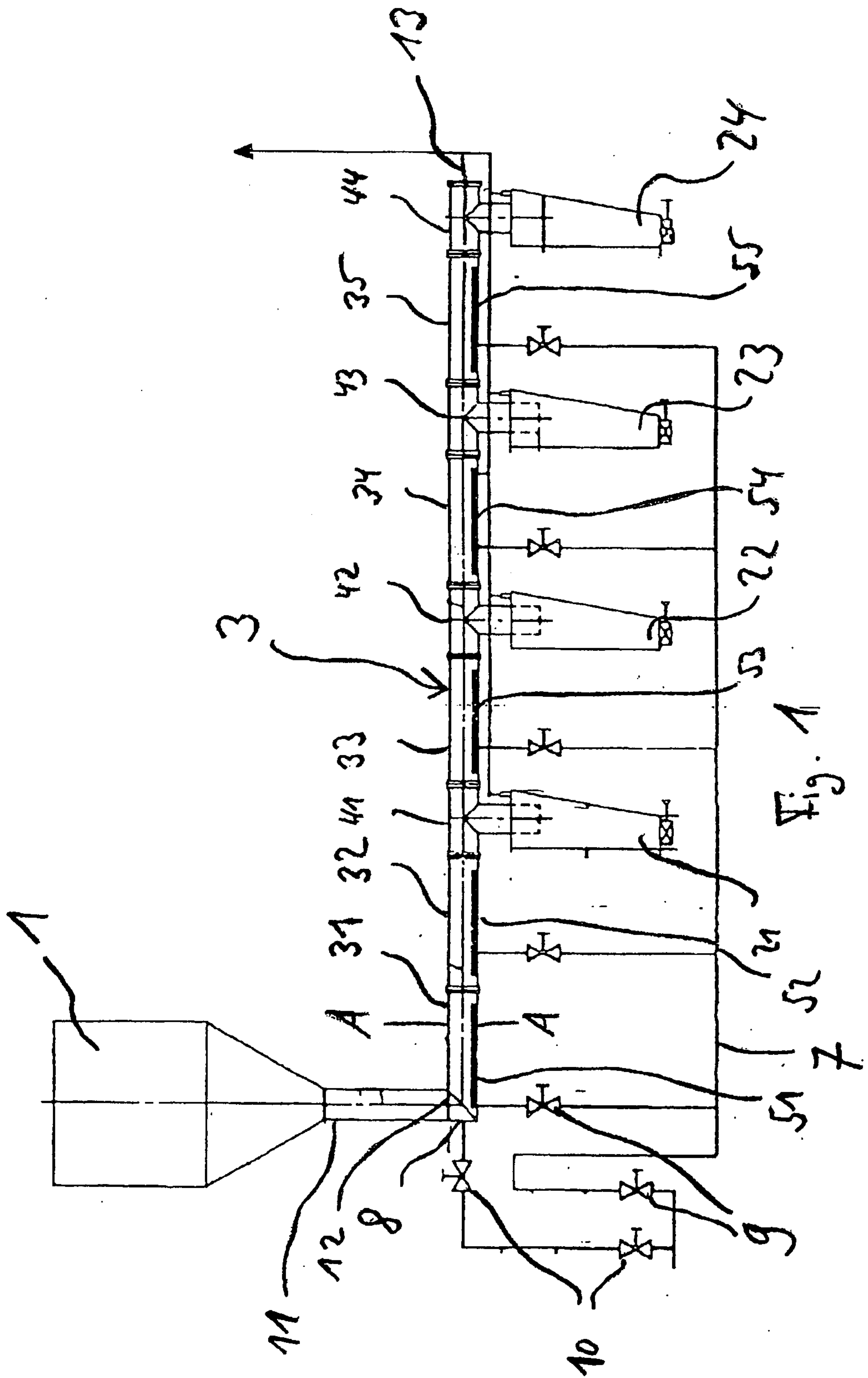

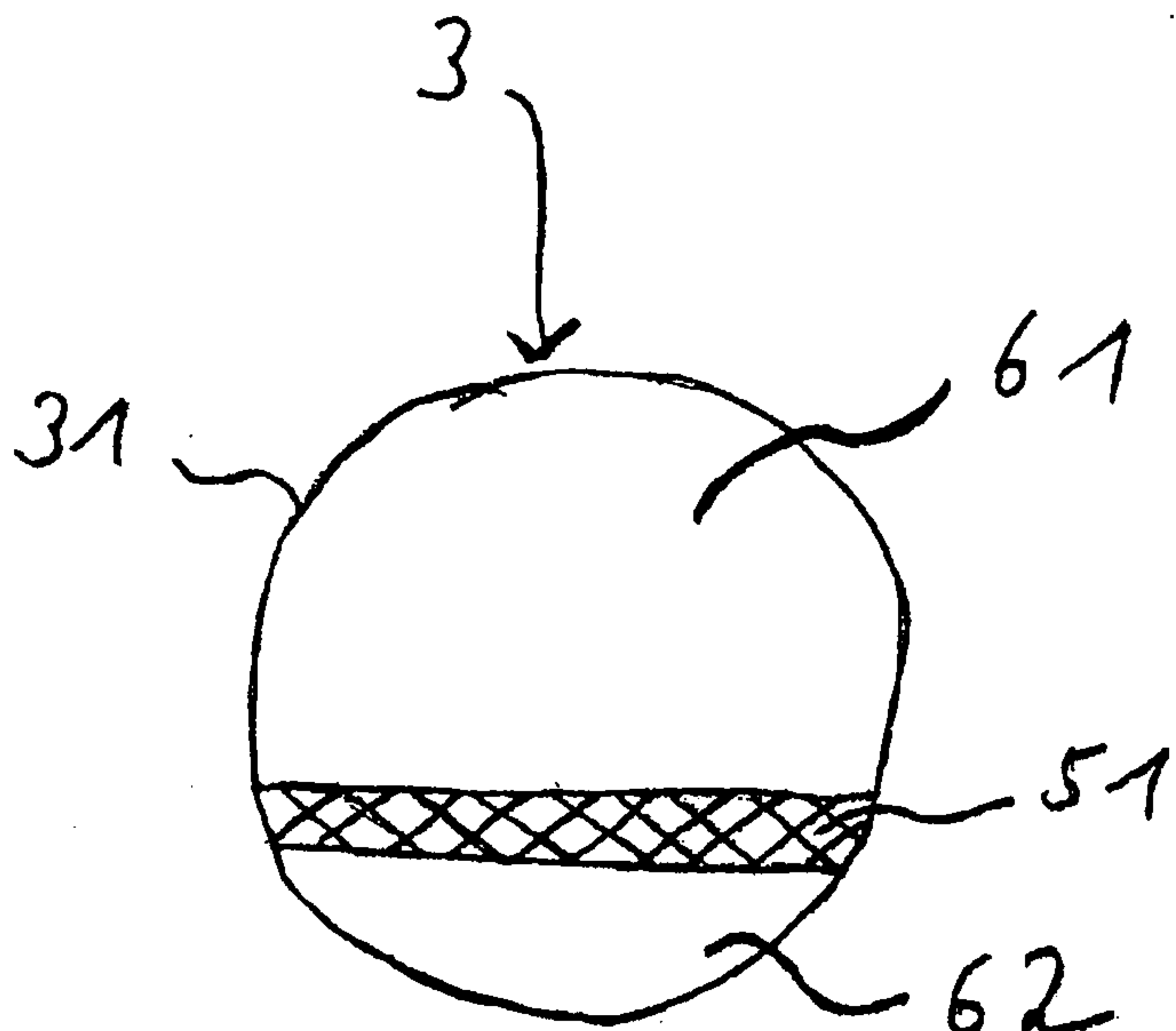

Fig. 2

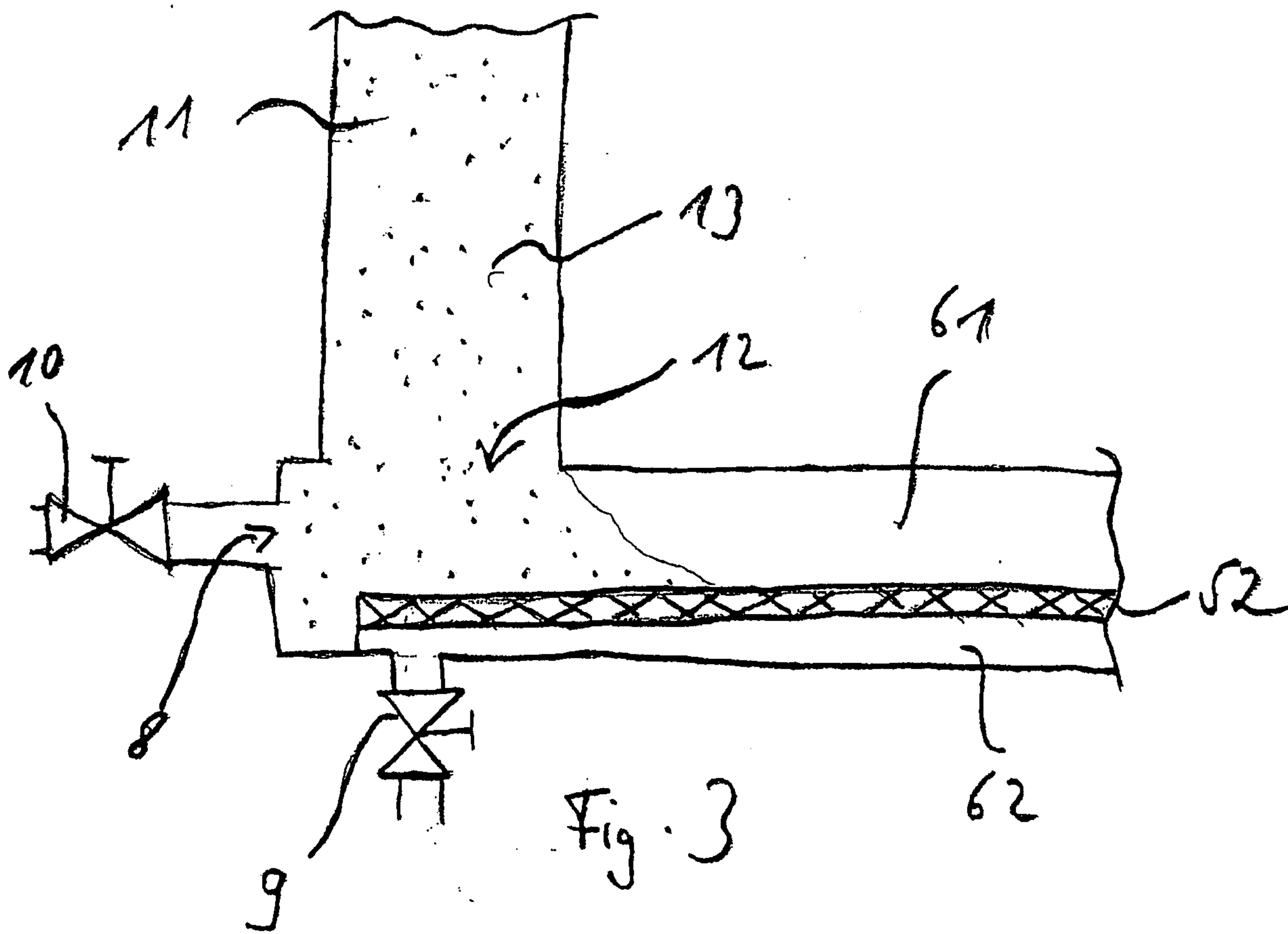

Fig. 3

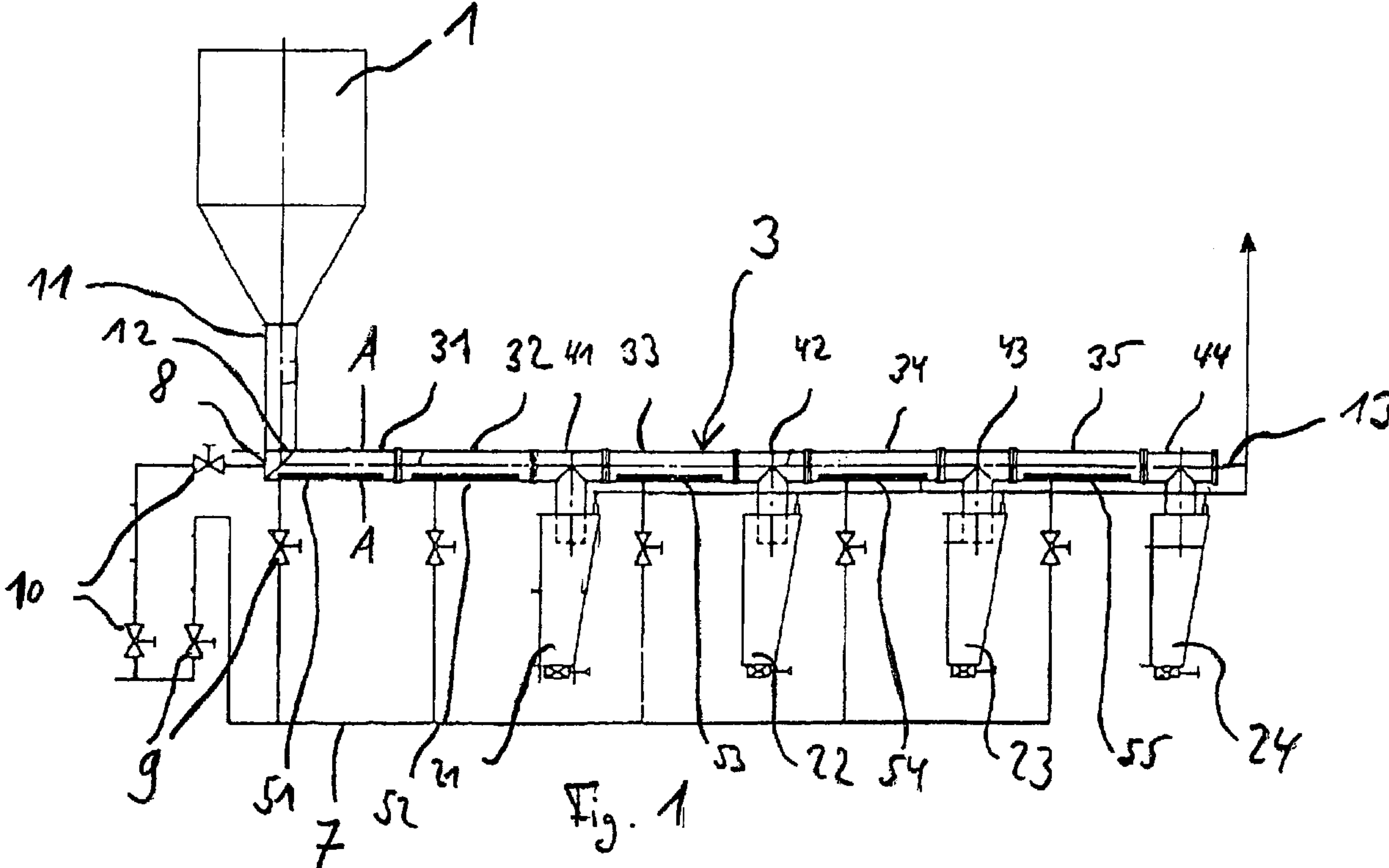

Fig. 1