

(72) FREITAG, HELMUT E., GB
(72) SHI, QINWEI, CA
(72) HARRINGTON, CHARLES A., US
(71) SPECTRAL DIAGNOSTICS, INC., CA
(51) Int.Cl.⁷ G01N 33/543, G01N 33/558
(30) 1998/08/06 (09/130,164) US
(30) 1999/07/14 (09/353,190) US
(30) 1999/07/14 (09/353,188) US
(54) **DISPOSITIF ET PROCÉDE DE BIOANALYSE**
(54) **ANALYTICAL TEST DEVICE AND METHOD**

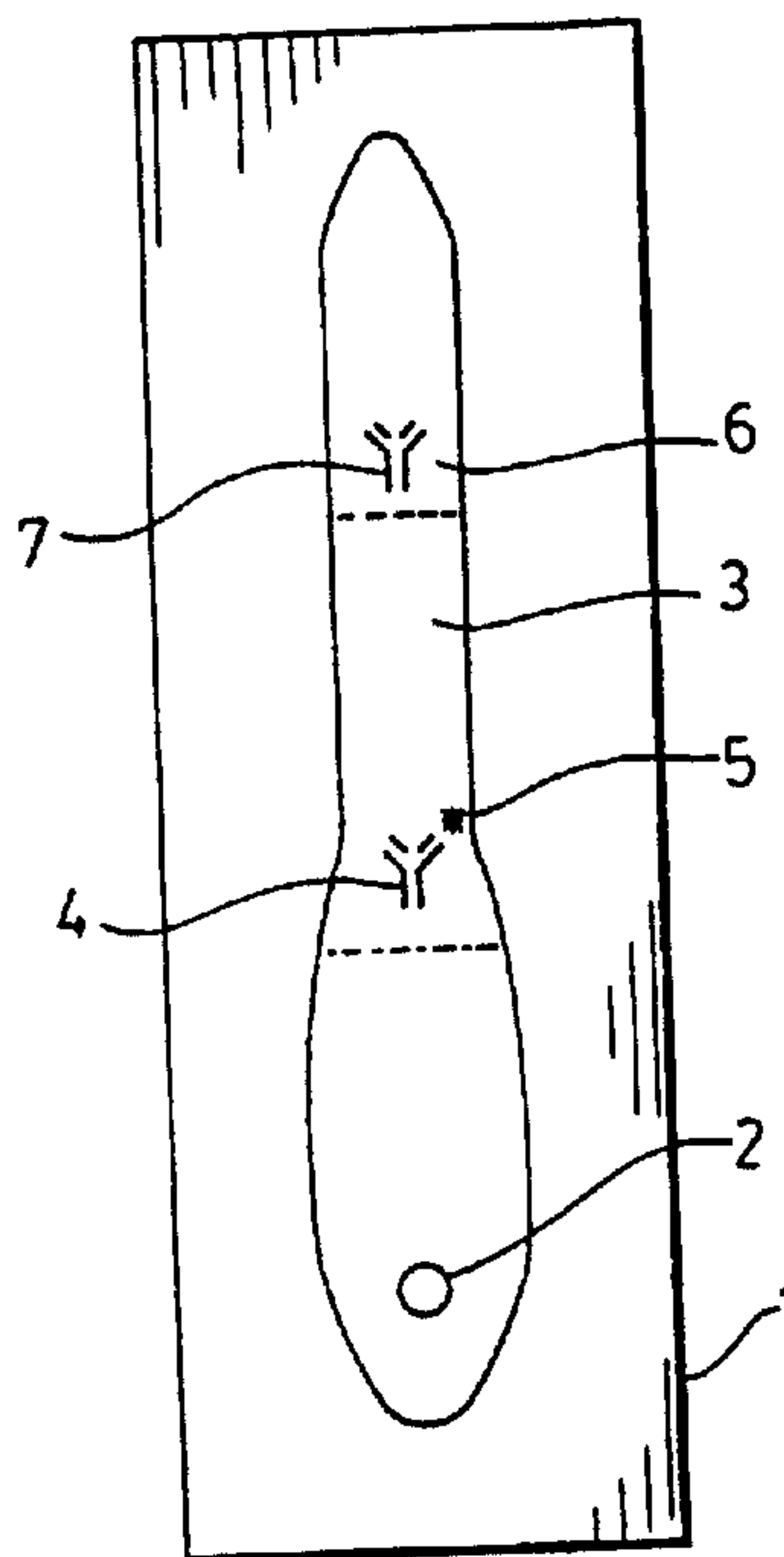

(57) An analytical test device is described for the immunochromatographic determination of the presence of one or more analytes in fluid samples. The device is configured such that the sample is allowed to enter the detection zone simultaneously from many different directions, eliminating stagnation of the flow of the sample. By selection of the porous substrate, the device also allows for the separation of the red blood cells from plasma, providing a rapid test for one or more analytes in a sample of whole blood. The device of the present invention may measure more than one analyte simultaneously from a single sample, either by having multiple immunochromatographic pathways fed by a single sample, or multiple analytes detected in the same pathway by way of multiple capture antibodies.

CORRECTED
VERSION*

PCT

WORLD INTELLECTUAL PROPERTY ORGANIZATION
International Bureau

INTERNATIONAL APPLICATION PUBLISHED UNDER THE PATENT COOPERATION TREATY (PCT)

(51) International Patent Classification ⁷ : G01N 33/543, 33/558	A3	(11) International Publication Number: WO 00/08466									
		(43) International Publication Date: 17 February 2000 (17.02.00)									
<p>(21) International Application Number: PCT/EP99/05712</p> <p>(22) International Filing Date: 6 August 1999 (06.08.99)</p> <p>(30) Priority Data:</p> <table border="0"> <tr> <td>09/130,164</td> <td>6 August 1998 (06.08.98)</td> <td>US</td> </tr> <tr> <td>09/353,188</td> <td>14 July 1999 (14.07.99)</td> <td>US</td> </tr> <tr> <td>09/353,190</td> <td>14 July 1999 (14.07.99)</td> <td>US</td> </tr> </table> <p>(71) Applicant (for all designated States except US): SPECTRAL DIAGNOSTICS, INC. [CA/CA]; 135-Unit 2, The West Mall, Toronto, Ontario M9C 1C2 (CA).</p> <p>(72) Inventors; and (75) Inventors/Applicants (for US only): FREITAG, Helmut, E. [DE/GB]; 144 Northfield Road, Birmingham B30 1DX (GB). SHI, Qinwei [CA/CA]; 4 Bradbrook Road No. 5, Etobicoke, Ontario M8Z 5V3 (CA). HARRINGTON, Charles, A. [US/US]; 603 West 13th Street, 1A-332 Austin, Austin, TX 78701 (US).</p> <p>(74) Agent: WINTER, BRANDL & PARTNER; Alois-Steinecker-Strasse 22, D-85354 Freising (DE).</p>		09/130,164	6 August 1998 (06.08.98)	US	09/353,188	14 July 1999 (14.07.99)	US	09/353,190	14 July 1999 (14.07.99)	US	<p>(81) Designated States: AE, AL, AM, AT, AU, AZ, BA, BB, BG, BR, BY, CA, CH, CN, CU, CZ, DE, DK, EE, ES, FI, GB, GD, GE, GH, GM, HR, HU, ID, IL, IN, IS, JP, KE, KG, KP, KR, KZ, LC, LK, LR, LS, LT, LU, LV, MD, MG, MK, MN, MW, MX, NO, NZ, PL, PT, RO, RU, SD, SE, SG, SI, SK, SL, TJ, TM, TR, TT, UA, UG, US, UZ, VN, YU, ZA, ZW, ARIPO patent (GH, GM, KE, LS, MW, SD, SL, SZ, UG, ZW), Eurasian patent (AM, AZ, BY, KG, KZ, MD, RU, TJ, TM), European patent (AT, BE, CH, CY, DE, DK, ES, FI, FR, GB, GR, IE, IT, LU, MC, NL, PT, SE), OAPI patent (BF, BJ, CF, CG, CI, CM, GA, GN, GW, ML, MR, NE, SN, TD, TG).</p> <p>Published With international search report.</p> <p>(88) Date of publication of the international search report: 18 May 2000 (18.05.00)</p>
09/130,164	6 August 1998 (06.08.98)	US									
09/353,188	14 July 1999 (14.07.99)	US									
09/353,190	14 July 1999 (14.07.99)	US									

(54) Title: ANALYTICAL TEST DEVICE AND METHOD

(57) Abstract

An analytical test device is described for the immunochromatographic determination of the presence of one or more analytes in fluid samples. The device is configured such that the sample is allowed to enter the detection zone simultaneously from many different directions, eliminating stagnation of the flow of the sample. By selection of the porous substrate, the device also allows for the separation of the red blood cells from plasma, providing a rapid test for one or more analytes in a sample of whole blood. The device of the present invention may measure more than one analyte simultaneously from a single sample, either by having multiple immunochromatographic pathways fed by a single sample, or multiple analytes detected in the same pathway by way of multiple capture antibodies.

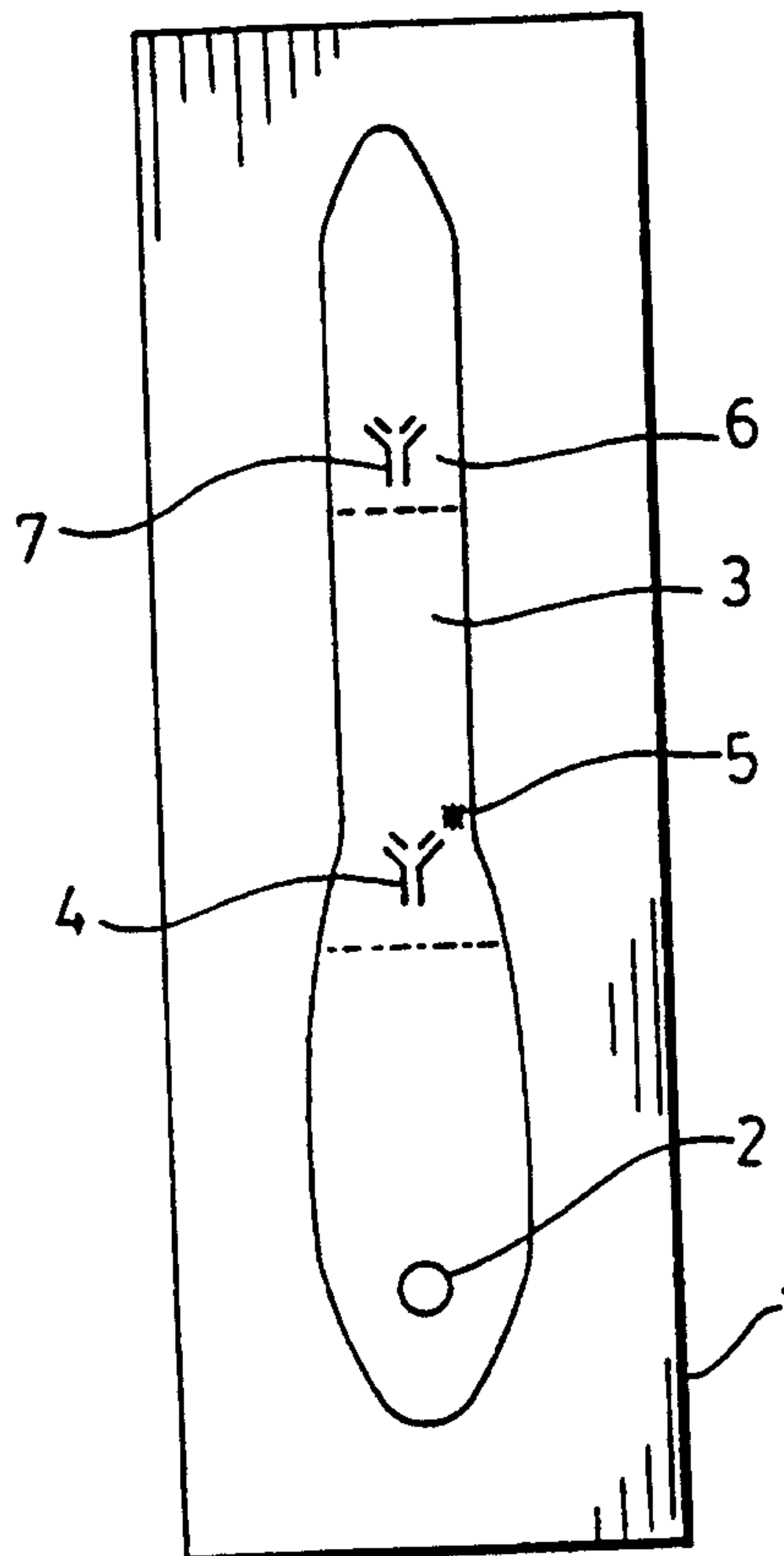

5

ANALYTICAL TEST DEVICE AND METHOD

FIELD OF THE INVENTION

10 This invention relates to analytical test devices and methods useful for analytical assays to determine the presence of analytes in fluid samples. It is especially useful for determining the presence of cardiac analytes in whole blood, although it is not so limited.

BACKGROUND OF THE INVENTION

15

The product and procedures of this invention can be utilized for many diagnostic purposes as well as for following the course of mammalian diseases and therapeutic treatments. It is applicable to many mammalian body fluids such as whole blood, serum, plasma and urine. Although this invention will be principally discussed as applied to detecting cardiac analytes it may also be applicable to other fields where antigen/antibody or equivalent reactions are utilized.

20

Many related assay procedures especially those including immunoassays may be performed using the device of the present invention and its disclosed modifications. For example, immunoassays or non-immunoassay test formats employing separation of red blood cells from plasma and a lateral fluid path may be employed. Analytes such as hormones for determining pregnancy or ovulation; viral, bacterial and fungal infectious microorganisms including H. pylori for gastrointestinal ulcers, drugs of use and abuse and tumor markers are non-limiting examples. Enzymatic assays such as those which determine levels of glucose and other analytes in blood by formation of a chromogen are also contemplated by the present invention.

30

A number of immunoassay procedures have recently been developed which utilize reactions taking place on dry porous carriers such as cellular membranes through which samples to be analyzed can flow by capillary action, the reaction products being detectable either visually or with an instrument such as a reflectometer. While not so limited, these procedures generally involve antigen/antibody reactions in which one member of the reactive pair is labelled with a detectable label. Typically, the label is an enzyme label or a particulate direct label, for instance a sol label such as gold. The art is well aware of many useful labels and their method of operation.

35

5

Typical immunochromatographic devices of this nature are described in several United States and foreign patents. For example, United States Patent 4,861,711 describes a device in which an analyte is detected by antigen/antibody reactions taking place in a series of coplanar membranes in edge to edge contact. Other devices are described in United States Patents:
10 4,774,192; 4,753,776; 4,933,092; 4,987,065; 5,075,078; 5,120,643; 5,079,142; 5,096,809;
5,110,724; 5,144,890; 5,591,645; 5,135,716. All of these patents describe laminated structures.

15 Devices including cellular porous membranes such as those described in the above identified patents are often difficult to manufacture because they are multi-layer and require several layers of porous materials and filtration strips to insure accurate results.

For detection of cardiac analytes in whole blood, it is necessary to remove red blood cells so that they will not interfere with visualizing or otherwise detecting the colored reaction
20 products normally produced in such immunoassay reactions.

Immunoassay devices when employed to detect cardiac analytes in whole blood utilize labelled antibodies which react with these antigens to produce detectable products. One widely utilized method for such diagnostic or analytical procedures utilizing antigen/antibody reactions
25 employs a labelled detector antibody which reacts with one epitope on the antigen to form a labelled antibody/antigen complex formed in a detection zone of a porous membrane strip. The complex moves along the membrane by capillary action until it contacts a fixed line containing a capture antibody with which it reacts at another epitope on the antigen to concentrate and form a detectable reaction product. Typically, the product is visibly detectable
30 because it is colored. With some constructions, the color is apparent to the naked eye. In more sophisticated devices, the presence or concentration of the antigen may be determined by measuring the intensity of the produced color or other property of the product with a suitable instrument, for example an optical sensor. The method is utilized in several devices used to detect cardiac analytes in whole blood. In all of these devices, it is necessary to prevent red
35 blood cells from entering the color development or capture area because they interfere with proper visualization of the colored reaction product because of the intense hue of the cells.

Much effort has been expended to prevent such interference. As a result, products of this nature heretofore proposed for analysis of whole blood include some means, such as a type of

5 filter to remove the red blood cells and form a plasma, so that there is no interference with the visibility of the color which is produced.

U.S. Patent No. 5,135,716 utilizes an agglutinating agent to assist in the separation of red blood cells. Other patents describe the use of paper or plastic filters.

10

The use of glass fiber fleece is described in United States Patent 4,477,575 to filter the red blood cells. Glass fiber fleece, however, simply adds another layer to the device. The principal difficulties arise from the problems of accurately placing several layers of thin flexible strips in proper registry in a laminar structure while at the same time retaining the sample placement zones, reaction zones and other areas of the membrane strips in proper communication with each other. The problems are further complicated by the difficulties of placing the completed membrane in or on a proper platform which is often a hollow casing with separable upper and lower members including fixed pillars and slots to prevent the membrane from moving and to retain selected membrane areas in proper position relative to viewing windows and other openings in the casing.

20

As a general rule, diagnostic devices such as those discussed above are often described as having an application zone to which the sample to be analyzed is added. The sample flows by capillary action along a predetermined pathway in a substrate, usually a nitrocellulose membrane, to a detection zone. The detection zone carries a mobile, labelled antibody to the analyte sought. If the analyte is present, a labelled antibody/analyte complex is formed which reacts with a fixed, i.e., immobilized capture antibody in a capture zone, downstream of the detection zone, to form a detectable product, usually one which is colored and visible to the naked eye.

25

It sometimes happens that the labelled antibody/analyte complex forms quite readily but does not sufficiently combine with capture antibody to produce an easily detectable signal. This might happen if no sufficient amount of complex contacts capture antibodies or contacts them in a configuration which is not optimum for forming a detectable reaction product. Other possible problems are insufficient incubation time or low antibody affinity.

30

These difficulties may be avoided by taking advantage of the biotin/avidin or biotin/streptavidin reaction or analogous reactions well known to the skilled artisan. These reactions are often used to increase the sensitivity of the diagnostic procedure.

5

In one application of this process, two antibodies are removably deposited in the detection zone and streptavidin is immobilized in the capture zone. The detector antibody is labelled, preferably with a metal such as gold, and reacts with one epitope on the analyte. The other antibody which is labelled with biotin reacts with another epitope on the analyte. The antibody mixture may be considered as a reagent system for use in detecting the presence of the analyte. If analyte is present, a complex containing gold labelled detector antibody/analyte/biotin labelled detector antibody will form in the detection zone. The complex will move through a cellular membrane by capillary action to the capture zone. When the complex reaches the immobilized streptavidin in the capture zone, the streptavidin binds to the biotin and concentrates the complex in a small area to form a detectable reaction product.

10
15

There are several known variations of this reaction. For example, the detection zone may contain a biotin labelled antibody together with streptavidin labelled with a colored label such as gold. The complex which forms and moves into the capture zone is an analyte/biotin labelled antibody/streptavidin gold-labelled complex which will move to the capture zone and concentrate in the capture zone by reaction with a capture antibody to form a detectable reaction product.

20

The above identified procedures have generally been described to involve reactions taking place on an elongated, rectangular, laminated devices with the sample application zone at one end associated with some type of filter layer. The sample, after filtration, contacts a mobile, labelled specific binding reagent in a detection zone to form a complex which moves along a cellular membrane to a distally placed specific binding reagent, i.e., the capture reagent which is immobilized in a line across the membrane. The complex reacts with the reagent and is concentrated along the reagent line to become visible.

25
30

Typically, the sample to be analyzed is placed in the application zone by the addition of several drops to the center of the zone or by dipping the application zone into a small volume of the sample.

35

There are a number of problems with these configurations, especially when the goal is high sensitivity and the result should be visible within only a few minutes.

High sensitivity can be achieved, for instance, by a capture line in a capture zone having a

5 small width, as compared to the width of the detection zone, so that the amount of labelled reaction product is captured within a small capture area and thereby give a more intense signal color.

10 Further, the sensitivity can be increased as more labelled volume moves across the capture line during the test procedure. The more labelled volume is needed, however, the greater the area of the detection zone must be.

15 If this area has the form of an elongated channel and is increased by simply increasing the length thereof, the consequence is a considerable increase in test time, because the velocity of the moving liquid front slows down exponentially with the total distance wetted.

20 Other shapes of this area (e.g. with a higher ratio of width to length) leading to a large width detection zone and a small width capture zone channel have the disadvantage of creating stagnation regions where there is little or no flow. In extreme cases significant amounts of the sample may never become involved in the reactions which form the detectable product.

25 This invention alleviates many of the problems aforesaid by providing a device which may be small enough to be hand held, although not necessarily so, and provides for rapid and efficient flow of the fluid to be analyzed. Although its most important present utility is for the analysis of whole blood to diagnose for the presence of cardiac analytes, it may be adapted to test for the presence of other components in a fluid such as a body fluid carrying an antigen which will form a complex with an antibody which may thereafter be detected, for example in a sandwich assay with another antibody. Cardiac analytes as are described in several of the above-mentioned patents may be employed in the emergency room to aid the physician in diagnosing
30 the cause of chest pain and to determine if the pain arises from a cardiac event.

It is towards several improvement in the features of the invention described above that the present application is directed.

35

BRIEF SUMMARY OF THE INVENTION

The solution to these problems as explained herein is that, according to a first aspect of the present invention, the sample is allowed to enter into the detection zone simultaneously from many different directions and the detection zone is designed in a way that the resulting flow

5 from the different directions all points to the entrance of the capture zone channel and all distances from entering the detection zone to said entrance are essentially the same.

10 This invention alleviates many of the problems aforesaid by providing a device which may be small enough to be hand held, although not necessarily so, and provides for rapid and efficient flow of the fluid to be analyzed. Although its presently preferred utility is for the analysis of whole blood to diagnose for the presence of cardiac analytes, it may be adapted to test for the presence of other components in a fluid such as a body fluid carrying an antigen which will form a complex with an antibody which may thereafter be detected, for example in a sandwich assay with another antibody.

15 Rapid and efficient flow of the fluid to be analyzed can be achieved by configuring the porous channels so that there is little or no opportunity for stagnation and so that the fluid enters a detection zone from a sample circulation channel from a multitude of points. The detection zone is designed so that the resulting front of the fluid moves in the direction of the entrance
20 end of the capture zone.

A particular advantageous aspect of the invention when employed to whole blood is the selection of a porous substrate which chromatographically separates red blood cells from plasma. The chromatographic separation is of particular importance compared to filtration of
25 particulate material because actual filtration may clog the cells of the media and impede or even stop flow. Moreover, as discussed above, filtration normally requires additional layers. In chromatographic separation, however, the particulate material continues to flow although at a slower rate than the carrier fluid so that there is little or no impedance of flow. With other biological samples chromatographic separation may not be necessary.

30 Another important feature of the invention, as will be explained below, is that all flow stops at a preselected point because the entire volume of the sample pathway in the porous carrier is wetted, and particulate material such as red blood cells does not interfere with the detection of the detectable reaction product.

35 The device according to a first aspect of this invention effects several improvements of the earlier devices, i.e. it provides a solution to the problems as explained herein is that the sample is allowed to enter into the detection zone simultaneously from many different directions and the detection zone is designed in a way that the resulting flow from the different directions all

5 point to the entrance of the capture zone channel and all distances from entering the detection zone to said entrance are essentially the same. Rapid and efficient flow of the fluid to be analyzed can be achieved by configuring the porous channels so that there is little or no opportunity for stagnation and so that the fluid enters a detection zone from a sample circulation channel from a multitude of points. The detection zone is designed so that the
10 resulting front of the fluid moves in the direction of the entrance end of the capture zone.

Further improvement can be archived with the following device according to a second aspect of the invention. For example, it uses less of the porous membrane, can be made smaller so that less material is used in its construction, and is faster acting. One of its most important
15 advantages, as will be apparent from the following explanation, is that even when a plurality of analytes are to be identified, the only change in structure required is the structure of the porous membrane, and not the supporting layers.

The improvements herein are directed to the configuration of the device and the interaction
20 between the porous membrane, on which the separation of plasma from blood cells occurs, and the top and bottom layers which cooperate to hold the membrane in the correct position. Furthermore, the top and bottom layers provide channels to conduct the sample from the application hole to and through the membrane to the capture antibodies while carrying out chromatographic separation of plasma from red cells. The first improvement is a
25 reconfiguration of the sample delivery channel such that the fluid is conducted from the application hole to the membrane through a channel comprising the top and bottom layers of the device. In contrast to the device according to a first aspect of the invention, no membrane is present in the sample delivery channel. The absence of membrane at this location is an improvement in that it reduces the amount of porous membrane required for the device, and
30 avoid concerns regarding the need to eliminate the porosity of membrane located in the sample delivery channel or any concerns regarding contact of the fluid sample with a material other than that comprising the top and bottom pieces (layers) of the device. The resulting product is less costly in both materials and labor to manufacture. The extent of porous membrane required is confined to the detector zone and capture zone. A configured interface between
35 the portion of the device comprising the sample delivery channel, and that containing the membrane and the sample circulation channel, is provided to form a capillary conduit for the blood sample to be channeled to the membrane in accordance with the device, without causing errant distribution of the sample.

- 5 A further advantage of this invention is that the same top and bottom layer components of the device are used in the manufacture of a number of different analytical tests. Only the membrane needs to be tailored for the detection of the specific analyte or analytes to be measured. For example, the reagents deposited or bound the membrane and their locations, and the shape of the fluid pathways on the membrane, can be individualized for each assay.
- 10 The top and bottom layers with the sample delivery channel and sample circulation channel are the same for every assay.

The sample delivery channel may also be configured to contain a predetermined volume of sample, and further, by means of an optional window or transparency, indicate to the user

15 when the sample delivery channel is full and thus adequate sample has been applied. A further improvement is a configuration of the sample delivery channel such that when the channel is full, the sample therein contained is delivered to the sample circulation channel and thereby initiates the immunoassay.

- 20 In a further embodiment, reagents such as the labeled detector antibodies may be provided within the channels of the device in the fluid path prior to the membrane, such that the reagents mix with the sample. The reagents may be provided as beads, microbeads, or lyophilized powder, by way of non-limiting examples in the aforementioned channels.

- 25 A principal feature of the devices of this invention is that the membrane does not extend the full length of the sample delivery channel. Another is that the sample delivery channel is designed so that a known predetermined volume of sample can be delivered to the operation section of the device.

- 30 It is therefore an object of this invention to provide an analytical test device as described above with a sample delivery channel formed in the lower surface of the top layer and with walls defined by the channel and the top surface of the bottom layer. Almost no membrane is present in the region of the sample delivery channel. In one embodiment, the sample delivery channel is configured with parallel sides, and is in operative communication with the sample
- 35 circulation channel. In another embodiment of the invention, the sample delivery channel is configured to contain the volume of sample needed to carry out the analysis in the device. In this embodiment, the end of the sample delivery channel which is in operative communication with the sample circulation channel is shaped to provide a narrowing of the sample delivery channel where it meets the sample circulation channel. In this embodiment, when the sample

5 delivery channel has filled with fluid up to the point where the fluid contacts the narrowed section, capillary action will channel the fluid from the sample delivery channel to the sample circulation channel, and then onto the membrane of the device. The sample then flows until the sample delivery channel drains of its predetermined volume, and the analysis is performed. As mentioned above, an optional observation window at the junction of the sample delivery
10 channel and the sample circulation channel may be provided to indicate to the operator that adequate sample has been added to the device to conduct the test, as when the sample delivery channel has filled completely with blood and the sample is channeled to the sample circulation channel, the observation window will indicate the presence of the sample.

15 As in the case of the device according to a first aspect of the invention, the device according to a second aspect of the invention alleviates the problems with the prior art devices because the sample is allowed to enter into the detection zone simultaneously from many different directions and the detection zone is designed in a way that the resulting flow from the different directions all point to the entrance of the capture zone channel and all distances from entering
20 the detection zone to said entrance are essentially the same. Rapid and efficient flow of the fluid to be analyzed is achieved by configuring the porous substrate (membrane) so that there is little or no opportunity for stagnation and so that the fluid enters a detection zone from a sample circulation channel from a multitude of points. The detection zone or channel is designed so that the resulting fluid front moves in the direction of the entrance end of the
25 capture zone channel.

Even further improvement can be archived with the following device according to a third aspect of the invention. The improvements of this device according to the third aspect of the invention are also directed to the configuration of the device and the interaction between the
30 porous membrane, on which the separation of plasma from blood cells occurs, and the top and bottom layers which cooperate to hold the membrane in the correct position. The present application is directed to devices in which the sample delivery channel is located on the top surface of the top layer, covered by a covering, and the sample is conducted to the sample circulation channel through a channel extending from the end of the sample delivery channel in
35 the top surface of the top layer to the sample circulation channel. When the sample enters and fills the sample circulation channel, it then moves chromatographically onto the membrane simultaneously from a plurality of points and initiates the chromatographic separation of plasma from red cells and the entry of the fluid into the detection zone from a multitude of points. The sample delivery channel of the present invention, by virtue of its location on the

5 upper surface of the top layer, offers several advantages. One advantage is the reduction in amount of membrane required in the device. The absence of membrane at this location is an improvement in that it reduces the amount of porous membrane required for the device, and avoid concerns regarding the need to eliminate the porosity of membrane located in the sample delivery channel or any concerns regarding contact of the fluid sample with a material other
10 than that comprising the top and bottom pieces (layers) of the device. The resulting product is less costly in both materials and labor to manufacture. A second advantage is that the location of the channel allows the user to view the filling of the channel. The test will not begin until the channel is filled; thus, no external sample measuring device is required. If the volume of the sample delivery channel is equal to the amount of sample required to conduct the test,
15 when the channel is filled, further application of sample may be stopped. Furthermore, the sample collection portion of the device may be shaped to conveniently access a drop of blood obtained by finger prick, filling the sample delivery with a small volume of blood, generally 30 to 50 μ l, and initiating the assay.

20 A further advantage of the device according to a third aspect of the present invention is that a reagent may be placed in the sample delivery channel, in the form of an applied layer or one or more solid particles, which will dissolve in the sample as it passes through the channel. Application of reagents at this location provides an easier means for manufacture of the device, as well as allowing the reagent to mix with the sample early before the sample reaches
25 the membrane.

Still a further advantage of this device according to a third aspect of the invention is that the same top and bottom layer components of the device are used in the manufacture of a number of different analytical tests. Only the membrane needs to be tailored for the detection of a
30 specific analyte or analytes to be measured. For example, the reagents deposited or bound to the membrane and their locations, and the shape of the fluid pathways on the membrane, can be individualized for each assay. The top and bottom layers with the sample delivery channel and sample circulation channel are the same for every assay.

35 As mentioned above, the sample delivery channel may also be configured to contain a predetermined volume of sample, and indicate to the user when the sample delivery channel is full and thus adequate sample has been applied. A further improvement is a configuration of the sample delivery channel such that when the channel is full, the sample therein contained is delivered to the sample circulation channel and thereby initiates the immunoassay. An

5 additional, optional feature is a test end indicator which indicates that the test is complete and may be read, and obviates the need for a timer. The windows allowing the use to view the test results and test end indicator may be openings in the top layer of the device, or the entire device may be constructed of a transparent material which is opaqued by printing or surface treatment at the areas not to be viewed.

10

A principal feature of the devices of this third aspect of the invention is the location of the sample delivery channel on the top surface of the top layer of the device, such that the membrane does not extend the full length of the sample delivery channel. Another feature is that the sample delivery channel is designed so that a known predetermined volume of sample
15 can be delivered to the operation section of the device. A further feature is the placement of reagents within the sample delivery channel for dissolution in the sample.

It is therefore an object of this invention to provide an analytical test device as described above with a sample delivery channel formed in the top surface of the top layer. The sample
20 delivery channel is covered by a cover, preferably transparent. No membrane is present in the region of the sample delivery channel. In one embodiment, the sample delivery channel is configured with parallel sides, and is in operative communication with the sample circulation channel. In another embodiment of the invention, the sample delivery channel is configured to contain the volume of sample needed to carry out the analysis in the device. In this
25 embodiment, the end of the sample delivery channel which is in operative communication with the sample circulation channel is shaped to provide a narrowing of the sample delivery channel where it meets the sample circulation channel. In this embodiment, when the sample delivery channel has filled with fluid up to the point where the fluid contacts the narrowed section, capillary action will channel the fluid from the sample delivery channel to the sample
30 circulation channel, and then onto the membrane of the device. The sample then flows until the sample delivery channel drains of its predetermined volume, and the analysis is performed.

As described herein, the device according to a third aspect of the invention alleviates the problems with the prior art devices because the sample is allowed to enter into the detection zone
35 simultaneously from many different directions and the detection zone is designed in a way that the resulting flow from the different directions all point to the entrance of the capture zone channel and all distances from entering the detection zone to said entrance are essentially the same. Rapid and efficient flow of the fluid to be analyzed is achieved by configuring the porous substrate (membrane) so that there is little or no opportunity for stagnation and so that

5 the fluid enters a detection zone from a sample circulation channel from a multitude of points. The detection zone is designed so that the resulting fluid front moves in the direction of the entrance end of the capture zone channel.

10

BRIEF DESCRIPTION OF THE DRAWINGS

Figs. 1, 2 and 3 are representations of the prior art. Figs. 1 and 2 represent attempted configurations to increase the labelled volume or, respectively, to increase the ratio of widths of the detection zone over the capture zone. Fig. 3 is the usual standard configuration in which
15 the width of the porous carrier, i.e. the membrane, is uniform throughout its length.

20

Fig. 4 shows a membrane configuration of a device of the invention suitable for detecting one or several analytes with one semicircular detection zone and one narrow capture zone channel. The border of the semicircular detection zone will connect to a sample circulation channel.

Fig. 5 shows the configuration of the lower surface of the top layer of a device of the invention suitable for use with the membrane of Fig. 4.

25

Figs. 6, 7 and 8 are sectional views along the lines A-A, B-B and C-C of Fig. 5.

Fig. 9 shows a membrane configuration of a device of the invention for detecting one or several analytes with one rectangular detection zone and one narrow capture zone channel.

30

Fig. 10 shows the configuration of the lower surface of the top layer of a device of the invention suitable for use with a membrane of Fig. 9.

Fig. 11 shows the configuration of a presently preferred membrane of the invention suitable for the detection of three different analytes via the biotin/streptavidin route.

35

Figs. 12 and 13 show the configurations of alternative porous membranes with one and three fluid pathways, respectively.

Fig. 14 shows an embodiment of the invention with two pathways and an arcuate circulation channel in a top layer.

5

Fig. 15 is a perspective view of a device of the invention.

Figs. 16A, 16B and 16C represent an exploded view of a device of the invention with a top member, a support member and a porous carrier in a configuration of Fig. 11.

10

Fig. 17A-D is a representation of a device of the invention having a sample circulation channel different from the one shown in Figs. 15 and 16 A-C.

15 Fig. 18 shows a membrane configuration for use in a device of this invention which is suitable for detecting one or several analytes with one semicircular detection zone and one narrow capture zone channel. The border of the semicircular detection zone will connect to a sample circulation channel.

20 Fig. 19A-B shows the configuration of the lower surface of the top layer and the top surface of the bottom layer, respectively, of a device of this invention suitable for use with the membrane of Fig. 18. Cross-sectional lines A-A, B-B, C-C, and D-D are shown in subsequent figures, representing the cross-sections through the assembled device.

25 Figures 20-23 are sectional views along the lines A-A, B-B, C-C and D-D, respectively, of Figure 19A. The cross-hatched top portion represents the cross-sectional portion of the top layer of the device, the open bottom portion represents the cross-sectional portion of the bottom layer.

30 Figure 24 shows a membrane configuration of a device of this invention for detecting one or several analytes with one rectangular detection zone and one narrow capture zone channel.

Figure 25 shows the configuration of a presently preferred membrane of this invention suitable for the detection of three different analytes via the biotin/streptavidin route.

35

Figures 26 and 27 show the configurations of alternative porous membranes with one and three fluid pathways, respectively.

Fig. 28A-B shows a configuration of the bottom surface of the top layer of a device of this

5 invention which includes a sample delivery channel of a predetermined volume with a window to indicate that the channel is full, and a construction which channels the fluid from the sample delivery channel to the sample circulation channel. A cross-section of the top layer of the device at section lines E-E is shown in Figure 28B.

10 Fig. 29 is a perspective view of a device of this invention.

Figs. 30A, 30B and 30C represent an exploded view of a device of this invention with a top member, a support member and a porous carrier in a configuration of Fig. 25.

15

Fig. 31 shows a membrane configuration for use in a device of this invention which is suitable for detecting one or several analytes with one semicircular detection zone and one narrow capture zone channel. The border of the semicircular detection zone will connect to a sample circulation channel.

20

Figs. 32-34 show the configuration of an example of a device of the present invention, and its component pieces, including the membrane holder, bottom piece, top piece, and sample delivery channel cover.

25 Fig. 35-36 show exploded view of examples of devices of the present invention, including cross-sectional views.

Figure 37 shows the configuration of a membrane of this invention suitable for the detection of three different analytes via the biotin/streptavidin route, with three fluid pathways.

30

Figures 38-40 depict devices of the invention with test reagent deposited in the sample delivery channel.

35

GLOSSARY

The following terms have the following general meaning as they are used in this specification and claims.

5 "Dry porous carrier" and "dry porous carrier layer" refer to a cellular product through which the sample to be analyzed can move by capillary action. As will be seen by the figures and understood by the description of the invention, the dry porous carrier (layer), which in this art is often referred to as a membrane, is configured by closing off some of the porous areas so that the fluid to be analyzed moves along defined pathways through selected channels.

10

"Top layer or top piece" is a layer in the analytical test device which is configured to cooperate with a bottom layer or bottom piece to hold the dry porous carrier (membrane) layer when the top and bottom layers are placed in registry to provide, in cooperation with the dry porous layer, pathways which control the direction of flow of the sample to be analyzed

15 through the device.

15

"Antigen" is a molecule which, in an animal, induces the formation of an antibody. The devices of this invention are useful for determining the presence of antigens in a fluid. They are especially useful for analyzing body fluids particularly whole blood, serum, plasma and urine.

20

Antigens are often referred to as "analytes".

"Cardiac analytes" are analytes which are released into the blood as a result of cardiac tissue deterioration.

25

"Channel" is any formed conduit through which the fluid sample under analysis flows in the analytical test device. A channel may be formed in the top layer or in the porous carrier layer itself. Since the top layer is generally a rigid plastic such as a polyacrylate or polymethacrylate, a channel may be formed by molding, stamping, machining or any equivalent process. In the porous layer, the channels may be formed by stamping the desired

30 configuration into the layer. They may also be designed into the porous layer by forming non-porous boundaries with wax or ink. Channels are said to be in an operative communication when a fluid in one channel flows directly into another.

30

"Semicircular", as the word is used herein is not limited to one half of a circle, but generally

35 refers to a circle area where a sector has been removed or to this sector itself.

35

"Circumscribed", as the word is used herein is not limited to an arcuate channel surrounding and conforming to a semicircular area of a porous membrane. The term includes - as will be apparent as this description continues - other configurations in which a sample circulation

5 channel conforms with the border of one or more detection zones of other configurations, for instance when the area of the carrier is polygonal or forms part of a polygon.

"Essentially" is a term used in connection with the distances between the points of sample entry into the detection zone and the entrance end of the capture zone channel. These
10 distances should be as similar as possible. Obviously, a semicircular area on the carrier to which an arcuate sample circulation channel conforms is a highly preferred configuration because all resulting distances between the arcuate border of the detection zone and the entrance end of the capture zone channel are the same.

15 "Rapid" means that a detectable product forms within a sufficiently short period of time, e.g. within about 5 to about 15 minutes, to permit the medical attendant to draw meaningful and useful conclusions.

"Efficient" means that a detectable product can be formed with a low volume of fluid, e.g. a
20 few drops of whole blood (from about 10 μ l to about 80 μ l), utilizing small amounts of reagents even when the antigen is present in very low concentrations as is usually the case with the cardiac analytes such as troponin I.

25 Figs. 1, 2 and 3 are prior art devices. In the figures, like numbers have similar meanings.

Fig. 1 is a view of one prior art device configured in an attempt to avoid the problems described above. In the figure, 1 is a porous cellular membrane such as nitrocellulose. The sample to be analyzed is added in area 2.
30

The detection zone 3 contains a mobile reactive reagent, for example a detection antibody 4 for troponin I in a plasma carrier. The antibody 4 is labelled with a label 5 such as gold.

For convenience, the devices of Figs. 1, 2 and 3 are shown as unilayer membranes. However,
35 in practice most of them would have a series of filtration layers over the area 2 so that only plasma carrying analyte would reach area 2. Alternatively, the red blood cells in the sample can be removed by clotting to form a serum. However, this is a separate step performed exterior of the device and normally requires separate filtration of the mixture of clotted blood cells with the serum before undertaking the test.

5

If the analyte is present, it will react with the labelled antibody 4 to form a labelled antibody/analyte complex which will move with the plasma by capillary action into capture zone 6 where it will react with capture antibody 7 fixed and immobilized in the capture zone 6. As a result, the labelled antibody/analyte complex will form a detectable reaction product in the area of capture antibody 7. Normally, antibody 7 is fixed in a line traversing the capture zone 6 and the reaction product will be visible to the naked eye. If the label is gold the line will be red to purple.

The problem which arises with a configuration such as shown in Fig. 1 is that the plasma carrying the analyte travels in all directions away from zone 2. A portion will travel towards the detection zone 3 and the capture zone 6. However, another portion will travel in the opposite direction and will thus never reach the capture zone 6.

Fig. 2 shows a prior art device employing flow barrier means 8 to increase the length of the pathway through which the sample must flow. The problem with this device is that the dead spots at the top periphery of the detection zone 3 create areas of stagnant flow.

Fig. 3 shows an elongated rectangular shaped porous substrate on which the same reactions take place as on Figs. 1 and 2. There is no fluid stagnation and none of the fluid is trapped. The principal problem with this standard device of Fig. 3 is that if the device is too short, not enough of the labelled volume contacts and reacts with the capture antibody to produce a sufficient quantity of reaction product to be detectable. If the device is too long, too much time will pass before the test result is available.

30

DETAILED DESCRIPTION OF THE INVENTION

The following describes a first aspect of the invention. As discussed above, the device of this invention may be employed to analyze a variety of liquid biological samples for the presence of an antigen. It is presently contemplated that the device will find its principal utility for the diagnosis of whole blood for the presence of cardiac analytes such as troponin I, troponin T, myoglobin, CK-MB, myosin light chain, carbonic anhydrase, fatty acid binding protein, glycogen phosphorylase BB, actin and any of a host of other known analytes which are found

35

5 in the blood as cardiac tissue deteriorates following an ischemic event such as angina or myocardial infarction. Accordingly, as an illustration of its breadth, the invention will be principally described as utilized in the diagnosis of cardiac events.

The prior art and its deficiencies have been discussed above in general and also in connection
10 with Figs. 1, 2 and 3.

Fig. 4 illustrates a dry porous carrier layer 1 of the invention configured for the analysis of whole blood for one analyte or a plurality of analytes by reactions between the analyte(s) and antibody pairs which react with different epitopes on the analyte in the classical
15 antigen/antibody reaction utilizing polyclonal or monoclonal antibody pairs, one member of the selected pair being labelled.

The figure shows carrier layer 1 in which the porosity of a selected section of the layer has been destroyed, e.g. by flow barrier means, to leave only one porous area defining semicircular
20 detection zone 3 with a border 11 and capture zone channel 6 which is closed at terminal end 12.

This membrane 1 which is preferably nitrocellulose or equivalent material chromatographically separates red blood cells to form a red blood cell front 13 and a plasma front 14 downstream
25 thereof.

The detection zone 3 contains labelled detection antibody 4 and 5 which reacts with the analyte, if present, to form a labelled antibody/antigen complex.

30 Although, for convenience, only one antibody is shown, the detection zone 3 may contain several different sorts of labelled antibodies.

The labelled antibody 4 is mobile, i.e., it is movably deposited in the detection zone 3 by any of several known means so that the labelled antibody/analyte complex once formed is free to
35 move downstream into the capture zone channel 6 for reaction with the capture antibody 7 fixed transverse of the capture zone channel 6 to form a detectable reaction product.

Again, for convenience, only one capture antibody line 7 is shown, but there may be a plurality of such lines, one for each analyte to be detected.

5

Capture zone channel 6 may optionally contain a product 15 which reacts with any substance normally present in blood, plasma, serum or other sample to produce a visible control product. The use of a control reaction is optional, but is preferred.

10 Fig. 5 shows the configuration of the lower surface of the top layer 16 which will be brought into registry with the membrane 1 of Fig. 4 to provide a device of the invention.

The top layer 16 has a "through hole" or "application hole" 17 for application of the sample. It is in operative communication with sample delivery channel 18 which communicates with
15 sample circulation channel 19. Sample circulation channel 19 is shown in an arcuate configuration in order to conform with the border 11 of the semicircular detection zone 3 of Fig. 4.

Sample circulation channel 19 is closed at both ends 20. It is formed with inner wall 21 and
20 outer wall 22 and is surrounded by a capillary trap 23 which functions to assure that the flow of sample is into the detection zone 3 of Fig. 4 at all points of border 11, and then into the capture channel 6 at its entrance end 6a.

Figs. 6, 7 and 8 are sectional views along the lines A-A, B-B and C-C, respectively, of Fig. 5.
25 Like numerals have the same meaning. Dimensions [mm] are merely for illustration. ---
Dimensions do not fit to scale.

Figs. 9 and 10 are similar to Figs. 4 and 5 except that the detection zone 3 is rectangular in
30 configuration and the sample circulation channel 19 which circumscribes the border 11 is similarly rectangular. As with Figs. 4 and 5 the device is shown with one mobile, labelled, detection antibody 4 and 5 and one fixed line of capture antibody 7.

The device of figure 9 and 10 can be employed to detect one or more than one analyte provided that there is no substantial amount of cross reaction.

35

Fig. 11 shows the configuration of a presently preferred membrane 1 of the invention in which the biotin/streptavidin reaction is utilized to diagnose a whole blood sample for the presence of three analytes. The configuration of the channels in the top layer can be readily devised from the foregoing explanation and the explanation which comes after. In the figure like

5 numerals have the same meaning as in the other figures. The design may be employed to ascertain the presence of the analytes myoglobin, troponin I or T and CK-MB in one small sample.

10 The membrane 1 is formed with three distinct pathways, one for each analyte leading from the borders 11a, 11b and 11c of three separate detection zones 3a, 3b and 3c. The detection zones are separated by blocking segments 24. The whole operative area is configured so as to provide three detection zones 3a, b and c in operative communications at their borders 11a, 11b and 11c with the sample circulation channel 19 on the lower surface of the upper layer 16 of the device (not shown in the figure). The detection zones 3a, 3b and 3c are in operative
15 communication with the corresponding entrance ends 6a, 6b and 6c of the respective capture zone channels.

The detection zone 3a contains two labelled antibodies, e.g. a biotin labelled antibody to CK-MB and a gold labelled antibody to CK-MB.

20

Generally, in Fig. 11 black circles stand for gold labelled antibodies while white circles stand for biotin labelled antibodies. No reference numerals are given for these detector antibodies in order not to clutter this figure.

25 As an example of the separation of the plasma from red blood cells during the operation of the device of Fig. 11, the red blood cell front in each of the three detection zones 3a, 3b, and 3c is shown as 13a, 13b, and 13c, respectively; the location of the respective plasma fronts are shown as 14a, 14b, and 14c, respectively.

30 If CK-MB is present in the sample, the complex which forms will enter the capture channel at entrance 6a to ultimately react with streptavidin at the streptavidin line 7a to produce a visible product.

35 Analogous reactions take place with other analytes such as troponin I or troponin T and with myoglobin in the separate pathways shown in the figure.

Figs. 12 through 16c are provided to further explain the invention and to show its versatility.

The same or other analytes may be similarly detected with conventional antigen antibody

5 reactions.

Fig. 12 illustrates a porous carrier layer 1 of the invention configure for the analysis of whole blood for one analyte such as troponin I.

10 The figure shows the porous carrier layer 1 in which the porosity of the layer has been destroyed in some areas to define detection zone 3 and capture zone channel 6 which is closed at terminal end 12.

The membrane 1 which is preferably nitrocellulose or equivalent material chromatographically
15 separates red blood cells to form a red blood cell front 13 and a plasma front 14.

In this embodiment of the invention, the detection zone contains a labelled detection antibody
4 which is constructed with label 5. The antibody reacts with the analyte, if present, to form a
labelled antibody/antigen complex.

20

The labelled antibodies 4, 5 are mobile, i.e., they are movably deposited by any of several
known means in the detection zone 3 so that the labelled antibody/analyte complex once
formed is free to move downstream into the capture zone channel 6 for reaction with a
capture antibody at line 7 fixed transverse of the capture zone channel 6 to form a detectable
25 reaction product.

25

Capture zone channel 6 may optionally contain a product 15 which reacts with any substance
normally present in blood, plasma, serum or other body fluid to produce a visible product. The
use of a control reaction is optional, but is preferred so that the operator will know that
30 sufficient blood or other fluid has been applied to the device to permit diagnostic reactions to
take place.

30

It will be noted that detection zone 3 and capture zone channel 6 are in operative
communication, i.e., fluid in detection zone 3 will flow by capillary action directly into capture
35 zone channel 6 through the entrance end 6a.

35

It will also be noted that the detection zone 3 has a semicircular geometry and thus an arcuate
border 11. The center of this arc where detection zone 3 is in operative communication with
the capture zone channel 6 can be considered a second or opposite end of the detection zone 3

5 through which fluid can flow into the entrance end 6a of the capture channel 6. As a result of
this configuration, every point on the border 11 is essentially equidistant from the entrance end
6a of the capture zone channel 6 and all of the fluid in the detection zone flows uniformly into
the capture zone channel 6 with successive segments of the sample reaching the entrance end
6a at substantially the same time. This uniformity of flow from several directions will be more
10 clearly understood in connection with the description of the top layer which appears below.

A major feature of the device of this invention is that the plasma stream which flows through
the detection zone 3 and capture zone channel 6 reaches the capture antibody line 7. There is
little or no labelled antibody/antigen trapped in the detection zone 3 as in the prior art
15 constructions. Instead there is rapid and efficient capillary flow of the fluid from the detection
zone 3 to the capture channel zone 6. The capture antibody 7 reacts with and concentrates the
labelled antibody/analyte complex to form the detectable product with maximum efficiency.
One advantageous result of this novel configuration is that the size of the diagnostic device
can be reduced to a minimum.

20 Any of a variety of labels available to the skilled artisan may be utilized in the devices of this
invention. Metal and enzyme labels are preferred. Metal labels are especially preferred due to
their remarkable sensitivity. Amongst the metals, gold is most preferred principally because it
is so widely employed for this type of reaction and its characteristics are so well understood.
25 Additionally, a gold signal can be enhanced to become readily visible by the use of a soluble
silver salt and a reducing agent in accordance with known procedures. The gold label acts as a
catalyst to reduce the silver salt to metallic silver, which deposits as a visible product. A
typical reactive pair is silver lactate, which serves as the source of reducible silver ions, and
hydroquinone as a reducing agent. The metallic silver forms a readily discernible black deposit
30 around each particle of gold.

The preferred particle size for gold labelled antibodies used in the invention is from about 35
to 65 nm, although appreciable variation can be tolerated depending on well understood
factors such as the concentration of the analyte and the affinity of the reactants.

35 If an enzyme label such as horseradish peroxidase is employed, reaction may be detected by
the addition of hydrogen peroxide and a dye such as ortho phenylenediamine in accordance
with standard procedures.

5 There may be a preincubation zone in the detection zone although it is not a necessary feature of the invention. The preincubation zone is employed to remove products present in the blood which may interfere with the desired reactions or make them difficult to detect. For example, if the device is to be used to detect cardiac analytes a typical interferant is the isoform of creatine kinase, CK-MM. Antibodies to the isoform CK-MB may cross react with CK-MM
10 and give false readings. This can be avoided by providing sufficient immobilized antibody to CK-MM in a preincubation zone upstream of the mobile antibody for CK-MB so that all of the CK-MM is removed before the moving sample reaches the detection antibody.

The device of Fig. 12 may utilize one or a plurality of labelled detector antibodies and capture
15 antibodies in immobilized capture antibody lines. When several labelled detectors are employed care must be exercised to avoid interfering cross reactions. It is often best that the antibodies be arranged in more than one detection zone to react with their specific analytes as explained below in connection with the other figures.

20 The device of Figs. 12 and 13 may also be prepared to employ the biotin/avidin reaction utilizing variations such as those described above. In the presently preferred variation as applied to the device of Fig. 12, a biotin labelled antibody and a gold labelled antibody are movably placed in the detection zone 3, where each of them reacts with a different epitope on the analyte to form a ternary complex composed of biotin labelled antibody/analyte/gold
25 labelled antibody which moves by capillary action into and through the capture channel zone 6 where it reacts with avidin or streptavidin to concentrate and form a detectable reaction product.

Of course, the antibodies employed in this invention may be either monoclonal or polyclonal.
30 Similarly equivalents of the biotin/avidin reaction can be employed. All of the reagents mentioned herein may be replaced with equivalents and are illustrative but not limitations of the invention.

The skilled artisan will recognize that any porous substrate that chromatographically separates
35 red blood cells and plasma from whole blood may be employed in this invention. However, nitrocellulose is preferred because it is readily available at reasonable cost. Nitrocellulose has been employed in chromatography and related fields for so many years that scientists and technicians are familiar with its properties.

5 Commercially available nitrocellulose sheets can be readily formed into any selected formation with any selected configuration of channels.

10 The nitrocellulose membranes of the invention may be characterized as sponge-like with a plurality of interconnected micropores of various sizes and dimensions giving rise to capillary forces within the membrane. This permits the biological fluid under investigation to move along the selected pathway.

15 For the separation of plasma from red blood cells in the practice of this invention, the area, geometry and dimensions of the various devices are so selected that the desired reactions take place in preselected areas as the liquid sample moves along predesigned pathways. For cardiac diagnosis of whole blood, these areas are selected on the basis of the relative speeds of the fronts of the red blood cell stream and the plasma stream, the kinetics of the desired reactions, the affinity of the antibodies for their respective epitopes and other factors which are well known to the skilled artisan or readily determined by conventional testing procedures.

20 While a variety of nitrocellulose materials are available in various cell sizes, the presently preferred porous carriers are those which, if used as a filter, that is filtering particles from a liquid stream flowing vertically to the horizontal surface of the membrane, will prevent the passage of particles larger than from 3 to 12 μ m. In the practice of the invention, membranes with a pore size from about 5 to 12 μ m, preferably 3 to 8 μ m, are preferred. Some variation is possible. However, as the pore size decreases, the mobility of a fluid within the membrane decreases, thereby increasing the time required for diagnosis. If the pores are too large, the time of passage reduces with the result that the reactants are not in contact with each other for a sufficient period for the diagnostic reactions to occur, or to occur to such a limited extent that they do not provide the desired information.

35 Nitrocellulose membranes with supporting polyester or other films are commercially available. These are preferred for use in this invention since unsupported membranes tend to be quite fragile, susceptible to fracture and difficult to handle in a mass production environment. Moreover, the films are impervious to the flowing fluids so that they do not interfere with the flow of liquid samples through the chosen pathways of the devices of this invention. One such membrane is available to a variety of pore sizes from Gerbermembrane of Gerbershausen, Germany.

5 The antibodies employed in this invention are prepared by standard techniques. See for example, Falfre, Howe, Milstein et al., Nature Vol. 266, 7, 550-552, April 1977. The pertinent disclosure of this seminal article on the preparation of monoclonal antibodies is incorporated herein by reference.

10 Procedures for fixing antibodies to substrates such as nitrocellulose are known and usable in producing the devices of this invention. Nitrocellulose is an avid binder for proteins. Hence, the immobile capture antibody need only be applied into the capture zone in a predetermined area. The labelled detector antibody may be movably affixed to the membrane by first saturating the detector zone with another protein such as bovine serum albumin.

15 Figure 13 shows the configuration of an alternate porous membrane with three fluid pathways, for use with three analytes. The configuration and operation of the membrane will be apparent from the explanation of the operation of the other devices.

20 Figure 14 shows an embodiment of the invention with top layer 16 and the porous carrier thereunder, with two pathways for detecting two analytes, shown as detection zones 3a and 3b, and capture zone channels 6a and 6b, respectively, in the porous carrier layer. The arcuate circulation channel 19 is shown in the top layer 16. This device shows an opening 17, optionally beveled, in the top layer running from its top surface to the inner surface
25 communicating with the shallow, narrow sample delivery channel 18, which then communicates with the sample circulation channel 19 formed in its bottom surface. The beveled opening is depicted further in Figs. 15 and 16A, as described below.

30 Fig. 15 is a perspective view and Figs. 16A, 16B and 16C an exploded view of a device of the invention showing a top layer 16, a "support layer" (or "bottom layer" or "bottom piece") 28, with a porous carrier 1 having a plastic backing layer 29 sandwiched between them. Through hole 17 runs from the upper surface 30 through to the bottom surface 31 in registry with a delivery channel 18 formed in the bottom surface 31 of the top layer 16.

35 Referring further to Figs. 15 and 16, sample delivery channel 18 is in operative communication with circulation channel 19 also formed in the bottom surface 31 of top layer 16. The circulation channel 19, having a design different from that shown in Fig. 5, is closed at both ends as shown by numeral 20. The circulation channel 19 is formed with inner walls 21 and outer walls 22. As shown in Fig. 16a, inner walls 21 form the boundary of an indent formed in

5 the bottom surface 31 of the top layer 16, referred to as capillary trap 23. Capillary trap 23 is shown extending into the area 33, but it is not necessary that it do so.

Referring to Figs. 16A and 16B, top layer 16 is attached to the support layer 28 by pins 34 which may be force fit into corresponding holes 35. Any other equivalent means of attachment
10 may be employed and the two layers 16 and 28 may be permanently or removably fixed.

Porous carrier 1 is shown in Fig 16B with a backing 29 such as a polyester film. It is held between layers 16 and 28. The carrier 1 may have the same exterior dimensions as layers 16 and 28 so long as there is an operative pathway through which the fluid added by way of
15 through hole 17 can pass through the delivery channel, the circulation channel, the detection zones and the capture zone channels to the closed ends 12 and 20, respectively, of the capture zone channels 27a, 27b, and 27c; and of circulation channel 19, respectively. The porous membrane 1 shown in Fig. 16C is configured similarly to the porous carrier of Fig. 11 for the detection of these analytes. Accordingly it contains three detection zones 24, 25 and 26
20 communicating with three capture zone channels 27a, 27b and 27c, respectively. (It should be noted that numerals 24, 25 and 26 as used here respectively correspond to numerals 3a, 3b and 3c of Fig 11 hereinabove, and numerals 27a, b, c correspond to numeral 6 of Fig. 4 hereinabove). The arcuate border 11 of the detection zones extend over the inner walls 21 of circulation channel 19 so that the flow of fluid when stopped at ends 20 will flow by capillary
25 action into the detection zones 24, 25 and 26.

The purpose of the capillary trap 23 now becomes apparent. If, in the absence of the capillary trap 33, the porous carrier 1 was in contact with a flat bottom surface of the top layer 16, the fluid in the circulation channel 19 would flow between that surface and porous carrier 1 rather
30 than through the membrane in its preselected pathway from the through hole 17 to the ends of the capture zone channels.

The flow is stopped at the ends of the circulation channel to make it possible to control the size of the sample. An optional window 39 over an optional extension of the sample
35 circulation channel shown as a dotted structure in Figs. 15 and 16a, may be provided to indicate that adequate sample has been applied to fill the channel.

If the top layer 16 is transparent the formation of a visible reaction product will be readily apparent. If the top layer 16 is opaque it will be constructed with one or more viewing

5 windows shown as 36, 37, 38. These windows as shown in Fig. 15 will be in registry with the capture zone channels so that the operator can view the formation of colored products or adjust an instrument such as a reflectometer to determine if a detectable reaction product has formed.

10 The device of Fig. 15 has three separate windows for purposes of illustration. In preferred devices, there will be one window extending transversely of the top surface 30 so that the results of all of the reactions can be viewed at once.

15 One of the advantages of this invention is that the devices whether intended to measure one, two or three antigens can have the same dimensions. Of course, the porous carrier layer 1 will be designed differently in each case. However, the top layer 16 does not require any changes to fit differently designed carrier layers 1.

20 Figure 17A is a perspective view and Figs. 17B, 17C and 17D an exploded view of the invention showing a top layer 16, a support layer 28, with a porous carrier 1 having a plastic backing layer 29 sandwiched between them. Through hole 17 runs from the upper surface 30 through to the bottom surface 31 of the top layer 16 in registry with a sample delivery channel 18 formed in the bottom surface 31 of the top layer 16. Sample delivery channel 18 is in operative communication with a sample circulation channel 19 also formed in the bottom surface 31 of top layer 16. The circulation channel 19 is closed at both ends as shown by numeral 20. The circulation channel 19 is formed with inner walls 21 and outer walls 22. As shown in Fig. 17B, inner walls 21 form the boundary of an indent formed in the bottom surface 31 of the top layer 16, referred to as capillary trap 23. Capillary trap 23 is shown extending into the area 33, but it is not necessary that it does so.

30 Referring further to the figures, top layer 16 is attached to the support layer 28 by pins 34 which may be force fit into corresponding holes 35. Any other equivalent means of attachment may be employed and the two layers 16 and 28 may be permanently or removably fixed.

35 Porous carrier 1 is shown in Fig 17C with a backing 29 such as a polyester film. It is held between support layers 16 and 28. The carrier 1 may have the same exterior dimensions as layers 16 and 28 so long as there is an operative pathway through which the fluid added by way of through hole 17 can pass through the delivery channel 18, the circulation channel 19, the detection zones 50, 51 and 52, and the capture zone channels 27a, 27b and 27c to the

5 closed ends 20 and 12, of circulation channel 19, and of the capture zone channels 27a, 27b, and 27c, respectively. (It should be noted that numerals 50, 51 and 52 as used here respectively correspond to numerals 3a, 3b and 3c of Fig 11 hereinabove, and numerals 27a, b and c correspond to numeral 6 of Fig. 4 hereinabove). The porosity of the portion of the porous carrier 1 situated in contact with the sample delivery channel 18 is destroyed in order
10 to prevent the flow of sample in the membrane. The porous membrane 1 shown in Fig. 17C is configured for the detection of three analytes. Accordingly it contains three detection zones or channels 50, 51 and 52, communicating with three capture zone channels 27a, 27b and 27c, respectively. The contiguous arcuate border 11 of the detection zones 50, 51 and 52 extend over the inner walls 21 of circulation channel 19 so that the flow of fluid when stopped at ends
15 20 will flow by capillary action into the detection zones 50, 51 and 52.

Referring further to Figure 17, the flow is stopped at the ends 20 of the circulation channel to make it possible to control the size of the sample. An optional window 39 over an optional extension of the sample circulation channel shown as a dotted structure 53 in Figs. 17A and
20 17B, may be provided to indicate that adequate sample has been applied to fill the channel. The corresponding portion of the carrier 1 is blocked out to limit flow to the optional channel, as well as the corresponding portion of the carrier beneath the sample delivery channel. A further advantage of the design of the device of the invention is that the same top and bottom layer pieces may be used for a variety of different devices.

25 If the top layer 16 is transparent, the formation of a visible reaction product will be readily apparent. If the top layer 16 is opaque it will be constructed with one or more viewing windows, shown in this example with a single window 37, and a test end indicator window 38. These one or more windows as shown in Fig. 17A will be in registry with the capture
30 zone channels so that the operator can view the formation of colored products or adjust an instrument such as a reflectometer to determine if a detectable reaction product has formed.

A optional test end indicator window 38 is provided to indicate when the test is over by, for example, the presence of a dye in the porous carrier 1 upstream from the test end indicator
35 window 38 but downstream from the portion of the porous carrier 1 under window 37 and the capture zone(s) 7. The dye is carried to the test end indicator window when sample has passed the capture zone. In another embodiment, as shown in Figure 18, the capture zone channel 6 may optionally contain a product 15 which reacts with any substance normally present in blood, plasma, serum or other body fluid to produce a visible product. This

5 configuration may be provided on the porous carrier 1 either in window 37 or in the test end indicator window 38.

The device depicted in Fig. 17A has a single window for viewing the capture zone and a test end indicator window for purposes of illustration. In preferred devices, there will be one
10 window extending transversely of the top surface 30 so that the results of all of the reactions can be viewed at once.

It will be noted from Figures 17A-17D that the dimensions of the sample delivery channel 18 are uniform throughout its length and that the membrane 1 extends well into the delivery
15 channel. It is also noted that the porosity of the portion of the membrane situated under the sample delivery channel 18 is destroyed to prevent the sample from spreading along the porosity of the membrane.

20 The following describes a second aspect of the invention. As mentioned above, the devices of this invention may be employed to analyze a variety of liquid samples, especially biological samples which can be analyzed by conventional antigen/antibody reactions of either the competitive or sandwich variety utilizing labelled reactants which emit a detectable signal. The skilled artisan will recognize that there are several applications of the device of the
25 invention.

It is presently contemplated that the invention will find its principal utility for the diagnosis of whole blood for the presence of cardiac analytes such as troponin I, troponin T, myoglobin, CK-MB, myosin light chain, fatty acid binding protein, glycogen phosphorylase BB, actin and
30 any of a host of other known analytes which are found in the blood as cardiac tissue deteriorates following an ischemic event such as angina or myocardial infarction. Accordingly, the invention will be principally described as utilized in the diagnosis of cardiac events. However, the device may be adapted for use to detect a wide variety of analytes by immunologic and other assay formats that take advantage of the separation of plasma from red
35 blood cells in a chromatographic fluid flow of the device of the present invention. In fact, and as will be seen below, a single device may be configured to perform a plurality of assays of more than one format, for example an immunoassay and an enzyme-based assay, by providing the particular assay components in each of the separate fluid paths available in the device.

5 The structures of the invention are especially useful for analyzing blood, serum and plasma for CK-MB, myoglobin, myosin light chain, troponin I, troponin C, troponin T, and complexes of troponin I, troponin C, troponin T containing at least two troponin subunits as described in U.S. Patents 5,747,274; 5,290,678; and 5,710,008, the pertinent contents of which are incorporated herein by reference.

10

It will be noted from Figures 17A, 17B, 17C and 17D that the delivery channel 18 of the previous device is angled just below the entry into the circulation channel 19. This makes it possible to shorten the overall length of membrane 1. It will also be noted that there is an extension of the porous carrier 1 which extends the full length of the sample delivery channel

15 18.

It has now been discovered that the length of the porous carrier (membrane) 1 can be reduced to only extend from the portion under the sample circulation channel as far as is necessary to define a fluid path from the sample delivery channel 18, to the sample circulation channel 19 and onto the membrane. Any small extension 105 of membrane 1 needed to extend into the sample delivery channel has its porosity destroyed such that the sample does not flow across the membrane, and that the fluid pathway is from the sample delivery channel to the sample circulation channel and then onto the membrane.

25 The sample delivery channel 18 can be either straight or contain an angle.

Another advantage of the device of this invention is that the section of the delivery channel 18 entering the circulation channel 19 can be reduced in cross section so that there will be capillary movement of the sample into that section of the sample delivery channel 18 having the smaller dimension. The particular advantage of this configuration is that the section of the sample delivery channel 18 having the larger volume can, in fact, be designed to hold the exact volume of sample needed to conduct the analysis.

Judicious placement of viewing windows as explained below will permit the operator to be in complete control of the whole operation.

35

As noted above, one improvement of this invention is a reduction in the size of the porous carrier 1 of the device, reducing the cost and avoiding the need of eliminating the porosity of the portion of the membrane in contact with the sample in the area of the sample delivery

5 channel 18, for example, by printing with a special ink. A further improvement is a sample delivery channel with a volume delivery means as described above, wherein once the sample delivery channel 18 is filled to its predetermined volume with sample, the complete sample volume empties into the sample circulation channel 19 to initiate the immunoassay. An optional window 91 at or near the junction of the sample delivery channel and the sample
10 circulation channel 19 serves to indicate that adequate sample has been applied to the device.

Fig. 18 illustrates a dry porous carrier layer 1 (also referred to as membrane 1) of the invention configured for the analysis of whole blood for one analyte or a plurality of analytes by reactions between the analyte(s) and antibody pairs which react with different epitopes on
15 the analyte in the classical antigen/antibody reaction utilizing polyclonal or monoclonal antibody pairs, one member of the selected pair being labelled.

The figure shows carrier layer 1 in which the porosity of a selected section or demarcated boundary of the layer has been destroyed to leave a defined porous area comprising a
20 semicircular detection zone 3 with a border 11 and capture zone channel 6 which is closed at terminal end 12. Border 11 includes a small extension 105 which, in the assembled device, is in registry with the junction thereabove between the sample delivery channel 18 and the sample circulation channel 19, as will be clearly seen in the cross-sectional view in Figure 21. This extension 105 will be in contact with the fluid to be analyzed. Its porosity is destroyed.
25 The portion of the membrane, and attendant extension 105 that extends beyond the sample circulation channel towards the sample delivery channel may be reduced to a very small size, or eliminated entirely, provided that the channels and corresponding structures which hold the membrane in position define the fluid path from the sample delivery channel to the sample circulation channel and then onto the membrane. The various capillary traps and cavity
30 described herein cooperate to maintain this defined fluid pathway. Other variations of these parts which achieve the aforesaid fluid pathway are embraced within the invention herein.

This membrane 1 which for analysis of whole blood is preferably nitrocellulose or equivalent material which chromatographically separates red blood cells to form a red blood cell front 13
35 and a plasma front 14 downstream thereof. For the analysis of other liquid samples, other materials may be preferable.

The detection zone 3 contains detection antibody 4 with detectable label 5 which reacts with the analyte, if present, to form a labelled antibody/antigen complex.

5

Although, for convenience, only one antibody is shown, the detection zone 3 may contain several labelled antibodies.

10 Antibody 4 is mobile, i.e., it is movably deposited in the detection zone 3 by any of several known means so that the labelled antibody/analyte complex once formed is free to move downstream into the capture zone channel 6 for reaction with the capture antibody 7 fixed transverse of the capture zone channel 6 to form a detectable reaction product.

15 Again, for convenience, only one capture antibody line 7 is shown, but there may be a plurality of such lines, one for each analyte to be detected.

20 Capture zone channel 6 may optionally contain a product 15 which reacts with any substance normally present in the fluid to be analyzed to produce a visible control product. The use of a control reaction is optional, but is preferred. This reaction indicates that the fluid has passed the capture zone, and functions as a test end indicator.

25 The dry porous carrier layer 1 (also referred to as membrane 1) need only be large enough to comprise the components shown in Fig. 18, and does not need to extend to the portion of the device comprising the sample delivery channel. As will be seen below, the present device may be configured to accommodate the smaller dry porous carrier layer 1, and still achieve the objects of the invention. By reducing the amount of dry porous membrane required for the device, the cost of materials is reduced. Further advantages of the reduced size of the dry porous carrier layer will be noted below, particularly, in the absence of membrane in the sample delivery channel.

30

Fig. 19A shows the configuration of the lower surface 23 of the top layer 16 which will be brought into registry with the top surface of bottom layer 28, shown in Figure 19B, with membrane 1 of Fig. 18 therebetween in area 103, to provide one embodiment of the invention.

35 The top layer 16 has a through hole 17 for application of the sample. It is in operative communication with sample delivery channel 18 which communicates with sample circulation channel 19. Sample delivery channel 18 has walls defining the channel, and a capillary trap 23 beyond the walls to confine the sample to the channel and prevent the sample from flowing between the apposed bottom surface of the top layer and the top surface of the bottom layer.

5 This is shown in cross-section in Figure 20. Sample circulation channel 19 is shown in an arcuate configuration in order to conform with the border 11 of the semicircular detection zone 3 of Fig. 18.

10 Sample circulation channel 19 is closed at both ends 20. It is formed with inner wall 21 and outer wall 22 and is surrounded by a capillary trap 23 which functions to assure that the flow of sample is into the detection zone 3 of Fig. 18 at all points of border 11, and then into the capture channel 6 at its entrance end 6a.

15 Figure 19B shows the configuration of the top surface of bottom layer 28. A flat rectangular area 103 recessed into the top surface 98 of the bottom layer 28 holds the membrane 1. The depth of area 103 from the top surface 98 is sufficient such that the top surface of membrane 1 is at the same level as top surface 98. Other configurations of area 103 are contemplated by the present invention, such as it extending to the borders of the top section 28. In another
20 embodiment, no recess is provided but the top layer 16 and bottom layer 28 are configured to hold the membrane 1 in the correct orientation. It is only necessary that the top and bottom layers come together with the membrane in between to define the fluid path from through hole 17 to the end of the membrane channel 12. The thickness of the various channels may be adjusted accordingly.

25 Membrane 1 is positioned to contact surface 99 of a cavity 102 located at the interface between the sample delivery channel 18 and the sample circulation channel 19. Figure 30C shows this cavity in a three-dimensional representation to assist in conveying the relationship between the parts of the device, as well as its function. When the top layer 16 and bottom layer 28 are aligned for operation of the device, the sample delivery channel in the bottom
30 surface of the top layer 16 passes along extension 101 until it meets circulation channel 19. The relative positions of cavity 102, the junction of the membrane with edge 99, and the junction of the sample delivery channel 18 and sample circulation channels 19 thereabove form a conduit such that the fluid flows from the sample delivery channel 18 into the sample circulation channel 19 above the membrane. The flow of fluid is confined to the sample
35 circulation channel 18 and onto the membrane 1 because the contact between membrane 1 and edge 99 is isolated by air from other surface contacts that may provide alternate capillary conduits for the fluid. The walls of the sample delivery channel 18, surrounded by a capillary trap 23 and extending from the through hole 17 towards the sample circulation channel 19, extend along extension 101 such that the capillary trap 23 of the lower surface of top layer 16

5 corresponds with the portion of cavity 102 of the top surface of bottom layer 28. These relationships will be further explained by reference to the cross-sectional views and figures 20-23, below. As such, the walls and capillary trap end at an air junction, also preventing the fluid from flowing beyond the walls of the sample delivery channel 18, leaving the fluid to continue to flow by capillary action to the sample circulation channel 19.

10

Figs. 20, 21, 22 and 23 are sectional views along the lines A-A, B-B, C-C and D-D, respectively, of Fig. 19A. Like numerals have the same meaning. Dimensions [mm] are merely for illustration. Dimensions do not fit to scale. Fig. 20 shows the sample delivery channel 18, formed as a capillary recess in the top layer 16, further defined by a bottom wall formed from the apposing portion of the top surface of the bottom layer 28 of the device, and further
15 defined by walls on each side which are further surrounded by a capillary trap 23 to contain the flow of fluid within the channel. The extent of the dimensions of the capillary trap on either side of the channel is optional, and may extend to or nearly to the perimeter of the top layer.

20

Figure 21 shows a longitudinal section along the direction of the sample delivery channel 18 where it meets the sample circulation channel 19, and further shows the position of the membrane thereunder and its contact with edge 99 of cavity 102 (as referred to in figure 19B). As described above, the membrane is positioned such that the only conduit from the sample
25 delivery channel is into the sample circulation channel and then onto the membrane, as no other possible conduits from the sample extend from this area, other than the thickness of the walls of the sample circulation channel 18, defined by capillary traps 23 on both sides, as described further below. The bottom of the sample delivery channel is in contact with the edge of the membrane only at edge 99 as shown in Figure 19B, and thus the membrane is
30 isolated by air from contact with any other parts of the device by virtue of cavity 102 extending below and to the sides of extension 101 of the top surface of the bottom layer 28. Thus, fluid flow is limited to the defined channels. The small extension 105 of the sample circulation channel as shown in Figure 18 corresponds to the portion of the membrane 1 that extends under the sample delivery channel at its junction with the sample circulation channel
35 19 and abuts edge 99 of cavity 102. This extension may be open, or preferably blocked by having its porosity destroyed, for example, by printing with a special ink. Its purpose is to prevent the blood from moving outside of the defined sample pathway on membrane 1, and to define the fluid pathway from the sample delivery channel to the sample circulation channel and then onto the membrane.

5

Figure 22 represents a cross-sectional view across the device at the level of the sample delivery channel 18 at the position where it extends over extension 101 into cavity 102 (as referred to in Figure 19B). The cavity 102 in combination with capillary trap 23 cooperate such that the fluid conduit is confined to the sample delivery channel 18, where it subsequently meets the sample circulation channel 19 over the membrane 1. The width of the walls of sample delivery channel 18 are confined within the width of extension 101, such that the outer edge of the walls meet capillary trap 23 and cavity 102, preventing any fluid flow beyond the thickness of the walls of the sample delivery channel 18. The width of the capillary traps 23 on the exterior of the sample delivery channel 18 may be varied in the construction of the device.

15

Figure 23 shows a cross section of the sample circulation channel 19. In operation, the sample enters the sample circulation channel 19 and rapidly moves by capillary action to the ends 20 of the sample circulation channel 19. Once the channel is filled, the sample contacts the membrane 1 all along the sample circulation channel 19 and passes onto the border essentially simultaneously from the entire arc of the sample circulation channel 19 onto border 11 and into the detection zone 3.

20

Fig. 24 is similar to Fig. 18 except that the detection zone 3 is rectangular in configuration and the sample circulation channel 19 which circumscribes the border 11 is similarly rectangular. As with Fig. 18 the device is shown with one mobile, labelled, detection antibody 4 and 5 and one fixed capture antibody 7. The device of Figure 24 can be employed to detect one or more than one analyte provided that there is no substantial amount of cross reaction.

25

Fig. 25 shows the configuration of a presently preferred membrane 1 of the invention in which the biotin/streptavidin reaction is utilized to diagnose a whole blood sample for the presence of three analytes. It is as described in Fig. 11 hereinabove, with the exception of the small extension 105 at the portion of the membrane 1 in contact with the junction between the sample delivery channel 18 and the sample circulation channel 19. The configuration of the channels in the top layer can be readily understood from the foregoing and following explanation. In the figure like numerals have the same meaning as in the other figures. The design may be employed to ascertain the presence of several analytes such as myoglobin, troponin I or T and CK-MB in one small sample.

30

The membrane 1 is formed with three distinct pathways, one for each analyte leading from the

5 borders 11a, 11b and 11c of three separate detection zones 3a, 3b and 3c. The detection zones are separated by blocking segments 24. The whole operative area is configured so as to provide three detection zones 3a, b and c in operative communications at their borders 11a, 11b and 11c with the sample circulation channel 19 on the lower surface of the upper layer 16 of the device. The detection zones 3a, 3b and 3c are in operative communication with the
10 corresponding entrance ends 6a, 6b and 6c of the respective capture zone channels.

The detection zone 3a contains two labelled antibodies, e.g. a biotin labelled antibody to CK-MB and a gold labelled antibody to CK-MB.

15 Generally, in Fig. 25 black circles stand for gold labelled antibodies while open circles stand for biotin labelled antibodies. No reference numerals are given for these detector antibodies in order not to clutter this figure.

As an example of the separation of the plasma from red blood cells during the operation of the
20 device of Fig. 25, the red blood cell front in each of the three detection zones 3a, 3b, and 3c is shown as 13a, 13b, and 13c, respectively; the location of the respective plasma fronts are shown as 14a, 14b, and 14c, respectively.

If CK-MB is present in the sample, the complex which forms will enter the capture channel at
25 entrance 6a to ultimately react with streptavidin at the streptavidin line 7a to produce a visible product.

Analogous reactions take place with other analytes such as troponin I or troponin T and with myoglobin in the separate pathways shown in the figure. The same or other analytes may be
30 similarly detected with conventional antigen antibody reactions.

Figs. 26 through 30c are provided to further explain the invention and to show its versatility.

Fig. 26 illustrates a porous carrier layer 1 of the invention configured for the analysis of whole
35 blood for one analyte such as troponin I. The figure shows the porous carrier layer 1 in which the porosity of the layer has been destroyed in some areas to define detection zone 3 and capture zone channel 6 which is closed at terminal end 12. The membrane 1 which is preferably nitrocellulose or equivalent material chromatographically separates red blood cells to form a red blood cell front 13 and a plasma front 14. In this embodiment of the invention,

5 the detection zone 3 contains a labelled detection antibody 4 which is constructed with label 5. The antibody reacts with the analyte, if present, to form a labelled antibody/antigen complex.

The labelled antibodies 4 are mobile, i.e., they are movably deposited by any of several known means in the detection zone 3 so that the labelled antibody/analyte complex once formed is
10 free to move downstream into the capture zone channel 6 for reaction with a capture antibody at line 7 fixed transverse of the capture zone channel 6 to form a detectable reaction product.

Capture zone channel 6 may optionally contain a product 15 which reacts with any substance normally present in blood, plasma, serum or other body fluid to produce a visible product. The
15 use of a control reaction is optional, but is preferred so that the operator will know that sufficient blood or other fluid has been applied to the device to permit diagnostic reactions to take place.

It will be noted that detection zone 3 and capture zone channel 6 are in operative
20 communication, i.e., fluid in detection zone 3 will flow by capillary action directly into capture zone channel 6 through the entrance end 6a.

It will also be noted that the detection zone 3 has a semicircular geometry and thus an arcuate border 11. The center of this arc where detection zone 3 is in operative communication with
25 The capture zone channel 6 can be considered a second or opposite end of the detection zone 3 through which fluid can flow into the entrance end 6a of the capture channel 6. As a result of this configuration, every point on the border 11 is equidistant from the entrance end 6a of the capture zone channel 6 and all of the fluid in the detection zone channel 3 flows uniformly into the capture zone channel 6 with successive segments of the sample reaching the entrance end
30 6a at substantially the same time. This uniformity of flow from several directions will be more clearly understood in connection with the description of the top layer which appears herein.

A major feature of the device of this invention is that when the plasma stream which flows through the detection zone 3 and capture zone channel 6 and reaches the capture antibody line
35 7, there is little or no labelled antibody/antigen trapped in the detection zone 3 as in the prior art constructions. Instead there is rapid and efficient capillary flow of the fluid from the detection zone 3 to the capture channel zone 6. The capture antibody 7 reacts with and concentrates the labelled antibody/analyte complex to form the detectable product with maximum efficiency. One advantageous result of this novel configuration is that the size of the

5 diagnostic device can be reduced to a minimum.

Any of a variety of labels available to the skilled artisan may be utilized in the devices of this invention. Metal and enzyme labels are preferred. Metal labels are especially preferred due to their remarkable sensitivity. Amongst the metals, gold is most preferred principally because it
10 is so widely employed for this type of reaction and its characteristics are so well understood. Additionally, a gold signal can be enhanced to become more readily visible by the use of a soluble silver salt and a reducing agent in accordance with known procedures. The gold label acts as a catalyst to reduce the silver salt to metallic silver, which deposits as a visible product. A typical reactive pair is silver lactate, which serves as the source of reducible silver ions, and
15 hydroquinone as a reducing agent. The metallic silver forms a readily discernible black deposit around each particle of gold.

The preferred particle size for gold labelled antibodies used in the invention is from about 35 to 65 nm, although appreciable variation can be tolerated depending on well understood
20 factors such as the concentration of the analyte and the affinity of the reactants.

If an enzyme label such as horseradish peroxidase is employed, reaction may be detected by the addition of hydrogen peroxide and a dye such as ortho phenylenediamine in accordance with standard procedures.
25

There may be a preincubation zone in the detection zone although it is not a necessary feature of the invention. The preincubation zone is employed to remove products present in the blood which may interfere with the desired reactions or make them difficult to detect. For example, if the device is to be used to detect cardiac analytes a typical interferant is the isoform of
30 creatine kinase, CK-MM. Antibodies to the isoform CK-MB may cross react with CK-MM and give false readings. This can be avoided by providing sufficient immobilized antibody to CK-MM in a preincubation zone upstream of the mobile antibody for CK-MB so that all of the CK-MM is removed before the moving sample reaches the detection antibody.

35 The device of Fig. 26 may utilize one or a plurality of labelled detector antibodies and capture antibodies in immobilized capture antibody lines. When several labelled detectors are employed care must be exercised to avoid interfering cross reactions. It is often best that the antibodies be arranged in more than one detection zone to react with their specific analytes as explained below in connection with the other figures.

5

The device of Figs. 26 and 27 may also be prepared to employ the biotin/avidin reaction utilizing variations such as those described above. In the presently preferred variation as applied to the device of Fig. 29 a biotin labelled antibody and a gold labelled antibody are movably placed in the detection zone 3, where each of them reacts with a different epitope on the analyte to form a ternary complex composed of biotin labelled antibody/analyte/gold labelled antibody which moves by capillary action into and through the capture channel zone 6 where it reacts with avidin or streptavidin to concentrate and form a detectable reaction product.

10

15

Of course, the antibodies employed in this invention may be either monoclonal or polyclonal. Similarly equivalents of the biotin/avidin reaction can be employed. All of the reagents mentioned herein may be replaced with equivalents and are illustrative but not limitations of the invention.

20

The skilled artisan will recognize that any porous substrate that chromatographically separates red blood cells and plasma from whole blood may be employed in this invention. However, nitrocellulose is preferred because it is readily available at reasonable cost. Nitrocellulose has been employed in chromatography and related fields for so many years that scientists and technicians are familiar with its properties. Commercially available nitrocellulose sheets can be readily formed into any selected formation with any selected configuration of channels.

25

30

The nitrocellulose membranes of the invention may be characterized as sponge-like with a plurality of interconnected micropores of various sizes and dimensions giving rise to capillary forces within the membrane. This permits the biological fluid under investigation to move along the selected pathway.

35

For the separation of plasma from red blood cells in the practice of this invention, the area, geometry and dimensions of the various devices are so selected that the desired reactions take place in preselected areas as the liquid sample moves along predesigned pathways. For cardiac diagnosis of whole blood, these areas are selected on the basis of the relative speeds of the fronts of the red blood cell stream and the plasma stream, the kinetics of the desired reactions, the affinity of the antibodies for their respective epitopes and other factors which are well known to the skilled artisan or readily determined by conventional testing procedures.

5 Figure 27 shows the configuration of an alternate porous membrane with three fluid pathways, for use with three analytes. The configuration and operation of the membrane will be apparent from the explanation of the operation of the other devices.

10 While, as aforesaid, it is preferred to design the diagnostic devices of this invention to detect more than one analyte, it is possible to design them with a single capture channel and multiple capture lines, one for each analyte, or with a plurality of capture channels each with a single capture line. This latter design, however, is not preferred because of the need for increased sample volume to ensure that reactions will take place in all channels. This defeats a principle aspect of the invention, namely to use the smallest sample with which it is possible to obtain
15 useful results.

A compromise which to some extent, but not completely alleviates the problem is to make the channels as small as possible and design them to be as close as possible to each other. The proximity of the channels, however, increases the difficulty of reading the results with
20 confidence because it is difficult to distinguish a capture line in one channel from a capture line in another.

The devices of the invention can be configured with multiple channels to have more than one channel including the test channel and/or a negative and positive control channel. Multiple
25 channels may each have more than one capture line. The designs will be readily apparent to the skilled artisan.

30 One channel, usually the middle channel will contain only fixed antibodies to the suspected analyte(s). The positive control channel will contain mobile labeled antibodies at the entrance to the channel and fixed antibodies deeper in the channel. The negative control channel will contain fixed antibodies, but will be blocked at its entrance to prevent the sample under test from entering. The negative test channel will be designed with an entrance hole through the support member to permit the addition of an analyte free material such as a buffer which will migrate to the capture antibodies.
35

The products and procedures of the invention, in addition to their value to test for cardiac analytes as described in detail above, may also be usefully employed in other medical procedures such as pregnancy and ovulation tests. They are especially useful to test for infections caused by particular viruses. For this utility they can be designed for both

5 competitive and sandwich assays. They can be used to test for antigens, antibodies, surface antigens, and virus particles such as gp120 of the AIDS virus.

Additionally, the products can be employed to test for drugs including drugs of abuse.

10 The reactions conducted in the various diagnostic procedures employed in the practice of this invention are generally well known to those skilled in the art. Most of them are ELISA tests conducted in a new and useful format. The advantages of this invention is that it provides new and useful formats on which the reactions can be conducted on small, hand-held instruments with speed and efficiency using low volumes of test liquids while concurrently
15 enabling the operator to have great confidence in the results.

While the foregoing descriptions show the one or more antibodies moveably deposited in detection zone 3, alternate locations for the detector antibodies as well as other reagents are embraced within the present invention. The detector antibody may be provided in the form of,
20 for example, lyophilized beads, such as a single larger bead or multiple smaller beads, placed within the fluid path upstream from the membrane, such that the bead dissolves in the fluid.

Non-limiting examples of such beads are described in commonly owned and copending application Serial No. (US Attorney's Docket No. 1112-1-999, filed July 14, 1999). This
25 copending application discloses a method for forming a plurality of uniform, lyophilized, rigid, detergent free reagent spheres each sphere comprising a carbohydrate matrix and having distributed therethrough at least one antibody useful to determine the presence of one or more antigens in a bodily fluid comprising the steps of forming a detergent free aqueous solution of the carbohydrate and the antibody reagent, forming uniform drops of the solution and adding
30 them to liquid nitrogen in a container at a rate such that each drop forms a separate frozen sphere in the nitrogen; maintaining the frozen spheres in the container covered with liquid nitrogen; and lyophilizing the frozen drops to remove the nitrogen and form dry spheres.

The bead may be provided in a sample delivery channel, the sample circulation channel, or at
35 their junction; a small cavity may be provided in the sample delivery channel or at the junction between the sample delivery channel 18 and the sample circulation channel 19, to hold the material. In another embodiment, the antibody is deposited in lyophilized form within the channel. Other reagents may be so provided, such as reagents to remove interfering substances, as described above. Furthermore, in a device with more than one fluid path in the

5 membrane for carrying out more than one assay, reagents common to the assays may be provided in the fluid path prior to the membrane, and reagents specific to each assay provided in the particular detection zone of the membrane as described above. These various configurations are embraced within the present invention.

10 As shown in Figure 28A and 28B, the sample delivery channel 18 in the bottom surface of the top layer 16 of the device may be designed with a preselected volumetric capacity in order to provide an adequate sample to fill the fluid path of the device and permit the practice of the assay as described above. The sample is applied to the through hole 17 and the sample fills the sample delivery channel starting from the end nearest the through hole 17 and filling
15 towards the opposite end. Once the sample delivery channel is filled, the preselected volume of sample has been applied. A window 91 may be provided, as described below, to indicate that the sample delivery channel has been filled to capacity; the top layer or the portion thereof located above the sample delivery channel may be made of a transparent material such that the filling may be easily observed. Furthermore, and as shown in an example of such a device in
20 Figure 28A, the sample delivery channel 18 in the top layer 16 may be designed such that once the sample delivery channel 18 has filled with sample to its preselected volume, contact of the moving front of the sample with a narrowed constriction 92 at the opposite end of the channel leading to a narrower capillary channel and to the sample circulation channel 19 will cause the sample in the sample delivery channel to be conducted by capillary action out of the sample
25 delivery channel 18 and into the sample circulation channel 19, then onto the membrane 1, as described above. Figure 28B shows a cross-section of the device of Figure 28A along the section marked E-E, showing the sample application through hole 17, the sample delivery channel 18, and the window 91 at the junction between the end of the sample delivery channel 18 and the sample circulation channel 19 to indicate that the sample delivery channel 18 has
30 been filled with adequate sample to conduct the test.

The optional window 91 optionally may be designed as a capillary channel with a flared section at the top surface of the top layer to easily indicate the presence of whole blood at the location. Other arrangements of the window are embraced herein. As mentioned above, an
35 alternate arrangement provides a transparency such that the filling of the sample delivery channel may be observed. In either instance, application of the sample to the through hole may be discontinued when the window indicates that the sample delivery channel is filled, or by direct observation of a full sample delivery channel.

5 Fig. 29 is a transparent top view of the assembled diagnostic device, and Figs. 30A-C the top layer 16, membrane 1, and bottom layer 28, respectively. The device illustrated is adapted to diagnose three analytes. The porous carrier is configured with three detection zones 50, 51 and 52 in operative communication with three capture zone channels 27a, 27b and 27c, respectively. For simplicity, this figure does not include the antibodies, red blood cell front, plasma front and other aspects of the novel device. These components are shown in previous figures.

The top layer 16 has a through hole 17 which may be beveled, running from its top surface to the inner surface communicating with the shallow, narrow, sample delivery channel 18, which communicates with the shallow, narrow, sample circulation channel 19 formed in the bottom surface of the top layer 16 with arcuate geometry to conform with the arcuate borders 11 of the detection zones 50, 51 and 52. The circulation channel 19 is closed at both ends 20. Optionally, an extension 53 of an end of the sample circulation channel may be provided with a view window above to serve as an indicator that adequate sample has been applied to the device.

Referring to Figs. 30A and 30C, top layer 16 is attached to the bottom layer 28 by pins 34 which may be force fit into corresponding holes 35. Any other equivalent means of attachment may be employed and the two layers 16 and 28 may be permanently or removably fixed.

25 Porous carrier 1 is shown in Fig. 30B with a backing 29 such as a polyester film. It is held between layers 16 and 28 in an optionally recessed area such that the membrane contacts edge 99 of cavity 102. Any such configuration of membrane 1 between top layer 16 and bottom layer 28 is embraced within the present invention so long as there is a operative pathway through which the fluid added by way of through hole 17 can pass through the delivery channel, the circulation channel 19, the detection zones and the capture zone channels to the closed ends of the capture zone channels 27a, 27b, and 27c. The porous membrane 1 shown in Fig. 30B is configured similarly to the porous carrier of Fig. 25 for the detection of three analytes. Accordingly it contains three detection zones 50, 51 and 52, communicating with three capture zone channels 27a, 27b and 27c, respectively. The arcuate border 11 of the detection zones extend over the inner walls 21 of circulation channel 19 so that the flow of fluid when stopped at ends 20 will flow by capillary action into the detection zones 50, 51 and 52.

5 The purpose of the capillary trap 23 now becomes apparent. If, in the absence of the capillary trap 23, the porous carrier 1 was in contact with a flat bottom surface of the top layer 16, the fluid in the circulation channel 19 would flow between that surface and porous carrier 1 rather than only through the membrane in its preselected pathway from the through hole 17 to the ends of the capture zone channels. The flow is stopped at the ends of the circulation channel
10 to make it possible to control the size of the sample. As mentioned above, an optional window 39 over an optional extension 53 of the sample circulation channel may be provided to indicate that adequate sample has been applied to fill the channel. As noted in Figure 28A, a window 91 indicating adequate sample volume application may be also provided.

15 If the top layer 16 is transparent, the formation of a visible reaction product will be readily apparent. If the top layer 16 is opaque it will be constructed with one or more viewing windows, one shown herein as 38, with an optional test window 37. These windows as shown in Fig. 30A will be in registry with the capture zone channels so that the operator can view the formation of colored products or adjust an instrument such as a reflectometer to determine if a
20 detectable reaction product has formed.

The device may have separate windows for viewing the capture zone for each analytes. In preferred devices, there will be one window extending transversely of the top surface 30 so that the results of all of the reactions can be viewed at once. Furthermore, there is an optional
25 window 39 corresponding to an extension of the sample circulation channel below (Figure 30B), to be used as an indicator that adequate sample has been added to fill the device. The appearance of sample, in particular, blood, under this optional window is an indication that adequate sample has been applied.

30 One of the advantages of this invention is that the devices whether intended to measure one, two or three antigens can have the same dimensions. Of course, the porous carrier layer 1 will be designed differently in each case. However, the top layer 16 and bottom layer 28 does not require any changes to fit differently designed carrier layers 1.

35 It will be seen that what has been described is a device and method which permits the detection of components in a liquid sample, for example cardiac analytes in whole blood, serum or plasma, by antigen/antibody reactions utilizing enzyme or direct labels in competitive or sandwich assays. In the devices of the invention, the reactants move along a pathway formed by successive interconnected channels in different planes of the support members and

5 the membrane.

While a variety of nitrocellulose materials are available in various cell sizes, the presently preferred porous carriers are those which, if used as a filter, that is filtering particles from a liquid stream flowing vertically to the horizontal surface of the membrane, will prevent the passage of particles larger than from 3 to 12 μm . In the practice of the invention, membranes with a pore size from about 5 to 12 μm , preferably 3 to 8 μm , are preferred. Some variation is possible. However, as the pore size decreases, the mobility of a fluid within the membrane decreases, thereby increasing the time required for diagnosis. If the pores are too large, the time of passage reduces with the result that the reactants are not in contact with each other for a sufficient period for the diagnostic reactions to occur, or to occur to such a limited extent that they do not provide the desired information.

Nitrocellulose membranes with supporting polyester or other films are commercially available. These are preferred for use in this invention since unsupported membranes tend to be quite fragile, susceptible to fracture and difficult to handle in a mass production environment. Moreover, the films are impervious to the flowing fluids so that they do not interfere with the flow of liquid samples through the chosen pathways of the devices of this invention. One such membrane is available to a variety of pore sizes from Gerbermembrane of Gerbershausen, Germany.

25 The antibodies employed in this invention are prepared by standard techniques. See for example, Falfre, Howe, Milstein et al., Nature Vol. 266, 7, 550-552, April 1977. The pertinent disclosure of this seminal article on the preparation of monoclonal antibodies is incorporated herein by reference.

30 Procedures for fixing antibodies to substrates such as nitrocellulose are known and usable in producing the devices of this invention. Nitrocellulose is an avid binder for proteins. Hence, the immobile capture antibody need only be applied into the capture zone in a predetermined area. The labelled detector antibody may be movably affixed to the membrane by first saturating the detector zone with another protein such as bovine serum albumin. As noted above, antibodies and other reagents may be deposited in or provided as beads in the fluid bath before the membrane. When the sample used in the assay is whole blood, and separation of red blood cells from the plasma is desired, the reagents provided in the device must not cause lysis of the red blood cells in the sample, to permit the separation.

5 The device of this invention can be readily manufactured by procedures already well known in the art.

10 As mentioned above, other assay procedures may be performed using the device of the present invention and its disclosed modifications. This includes both qualitative and quantitative assays, both immunoassay and non-immunoassay formats. Enzyme-based assays, such as the quantitation of glucose in whole blood using the combination of glucose oxidase and peroxidase, with the appropriate reactants and chromogenic substrate to generate a color in proportion to the level of glucose in the sample, may be configured to operate using a device
15 of this invention. The skilled artisan will recognize the adaptability of other assay formats to the present device.

20 The following describes a third aspect of the invention. As mentioned above, the devices of this invention may be employed to analyze a variety of liquid samples, especially biological samples which can be analyzed by conventional antigen/antibody reactions of either the competitive or sandwich variety utilizing labelled reactants which emit a detectable signal. The skilled artisan will recognize that there are several applications of the device of the invention.

25 It is presently contemplated that the invention will find its principal utility for the diagnosis of whole blood for the presence of cardiac analytes such as troponin I, troponin T, myoglobin, CK-MB, myosin light chain, fatty acid binding protein, glycogen phosphorylase BB, actin and any of a host of other known analytes which are found in the blood as cardiac tissue
30 deteriorates following an ischemic event such as angina or myocardial infarction. Accordingly, the invention will be principally described as utilized in the diagnosis of cardiac events. However, the device may be adapted for use to detect a wide variety of analytes by immunologic and other assay formats that take advantage of the separation of plasma from red blood cells in a chromatographic fluid flow of the device of the present invention. In fact, and
35 as will be seen below, a single device may be configured to perform a plurality of assays of more than one format, for example an immunoassay and an enzyme-based assay, by providing the particular assay components in each of the separate fluid paths available in the device.

The structures of the invention are especially useful for analyzing blood, serum and plasma for

5 CK-MB, myoglobin, myosin light chain, troponin I, troponin C, troponin T, and complexes of troponin I, troponin C, troponin T containing at least two troponin subunits as described in U.S. Patents 5,747,274; 5,290,678; and 5,710,008, the pertinent contents of which are incorporated herein by reference.

10 Fig. 31 illustrates a dry porous carrier layer 1 (also referred to synonymously as membrane 1) of the invention configured for the analysis of whole blood for one analyte or a plurality of analytes by reactions between the analyte(s) and antibody pairs which react with different epitopes on the analyte in the classical antigen/antibody reaction utilizing polyclonal or monoclonal antibody pairs, one member of the selected pair being labelled.

15 The figure shows carrier layer 1 in which the porosity of a selected section of the layer has been destroyed to leave only one porous area defining semicircular detection zone 3 with a border 11 and capture zone channel 6 which is closed at terminal end 12. Alternatively, and preferably, the porosity may be destroyed along the boundary of the zone referred to above,
20 confining the sample to the interior of the boundary.

This membrane 1 which for analysis of whole blood is preferably nitrocellulose or equivalent material which chromatographically separates red blood cells to form a red blood cell front 13 and a plasma front 14 downstream thereof. For the analysis of other liquid samples, other
25 materials may be preferable.

The detection zone 3 contains detection antibody 4 with detectable label 5 which reacts with the analyte, if present, to form a labelled antibody/antigen complex.

30 Although, for convenience, only one antibody is shown, the detection zone 3 may contain several labelled antibodies.

Antibody 4 is mobile, i.e., it is movably deposited in the detection zone 3 by any of several known means so that the labelled antibody/analyte complex once formed is free to move
35 downstream into the capture zone channel 6 for reaction with the capture antibody 7 fixed transverse of the capture zone channel 6 to form a detectable reaction product. It will be noted from the further description below that the detection antibody may be provided in the fluid path before the membrane, for example, in the form of beads or deposited material in the sample delivery channel, sample circulation channel, or in a chamber therebetween.

5

Again, for convenience, only one capture antibody line 7 is shown, but there may be a plurality of such lines, one for each analyte to be detected.

10 Capture zone channel 6 may optionally contain a product 15 which reacts with any substance normally present in the fluid to be analyzed to produce a visible control product indicating that fluid has passed the capture zone. The use of a control reaction is optional, but is preferred.

15 The present application offers further improvements over the above-mentioned devices. The device of the present invention, as shown in the example of Figures 32-34, has a sample delivery channel 18 which extends over the top surface of the device, covered by a cover piece 75 shown in Figure 34A. Non-limiting examples of the components of the present device will described in further detail below. The advantages of the sample delivery channel on the top surface of the device are severalfold. First, the filling of the sample delivery channel can be viewed by the operator of the device, and, if the capacity of the sample delivery channel is equal to the amount of sample necessary to perform the test, application of sample may be 20 stopped when the operator notes that the channel is completely filled. Secondly, the sample delivery channel may be placed at any suitable location on the top surface of the device, including placement over the portion of the device housing the membrane, as long as the sample delivery channel on the top surface of the top piece does not interfere with the 25 membrane or other components of the device between the top and bottom pieces, or viewing or reading the results. This allows a smaller device to be provided, its size limited only to the size of the membrane. The reduced membrane size and the reduction or elimination of any extension of the device comprising the sample delivery channel provides a smaller device with less membrane, reduces the cost of manufacture, packaging and shipping, and provides a more 30 user-friendly and environmentally-friendly device.

One convenient position for the sample delivery channel is such that the sample application hole of the device is at a location on the device which tapers to a point, such as is shown in Figure 32. This provides a convenient means for filling the device with whole blood obtained 35 by finger puncture, by holding the sample application opening 60 to the drop of blood, wherein the sample, usually 30 to 50 μ l, is drawn by capillary action into and fills the sample delivery channel, after which the sample is conducted to the sample circulation channel and then onto the membrane.

5 Furthermore, the sample delivery channel may be preloaded with a dried test reagent, such as gold conjugated antibodies to the analyte, and/or biotinylated antibodies to the analyte, to operate the immunoassay as described herein. Preloading may comprise application of a solution comprising the reagent(s) which is then dried in the sample delivery channel, or placement of particles, for example, lyophilized beads comprising test reagents, in a defined recess or cavity in the channel. Upon contact with the sample, the dry reagents dissolve in the sample and are carried along the fluid path.

15 Another feature of the device of this invention is that the section of the sample delivery channel 18 at location 92 near the junction of the circulation channel 19 can be reduced in cross section so that there will be capillary movement of the sample into that section of the sample delivery channel 18 having the smaller volume. The particular advantage of this configuration is that the sample delivery channel 18 can be designed to hold the exact volume of sample needed to conduct the analysis. As the sample delivery channel fills with sample and the sample contacts the portion of the channel reduced in cross-section, capillary action will cause the sample to move to the further reduced cross-sectional portion and thus transfer the sample from the sample delivery channel to the sample circulation channel and initiate the chromatographic separation of plasma from blood and the immunoassay process.

25 Figures 32-34 show in detail the components of an example of a device of the present invention. Numerous alternate configurations are possible and are embraced by the invention herein. The skilled artisan will readily understand the other configurations possible, in particular, the further reduction in size of the device by placing the sample delivery channel over the membrane portion, as shown in Fig. 35A and described in more detail below. Fig. 32A shows a top view of the top piece 16 of the device, designed to hold the porous carrier 1 (membrane 1) between it and the bottom piece 28 shown in Figure 33. Top piece 16 includes window 41 which is provided to allow the operator to view the capture zone 7 as well as an optional test-end indicator zone 15 on the membrane 1. In another embodiment window 43 is provided to view the end of the fluid path to indicate completion of the test. Top piece 16 also includes part of the sample delivery channel 18, the sample circulation channel 19, as seen from below in Figure 32D, the latter having the same characteristics as that described e.g. in Fig. 5 hereinabove. Figure 32B shows a front view, and Figure 32C a side view, of the top piece.

Figure 32E shows a composite, cross-sectional view of an example of an assembled device of

5 the present invention, showing the top piece 16, the bottom piece 28, the sample delivery channel cover piece 75. The figure also shows the fluid path: the sample application port 60, the sample delivery channel 18, the narrowing junction 92 providing communication between the sample delivery channel 18 and the sample circulation channel, the membrane 1, the window for viewing the capture zone(s) 41, and the test-end indicator window 43.

10 The windows of the device for viewing the capture zone and the optional test end indicator zone may be openings in the top layer of the device, or the top layer may be made of a transparent material which is opaqued by printing or surface treatment to opaque the portions which are not to be viewed. In one embodiment, test-end indicator zone 15 contains a
15 product which reacts with any substance normally present in the fluid to be analyzed to produce a visible control product viewable through window 43. In another embodiment a product such as dye is deposited on the membrane 1 at location 15 not viewable through window 43. The dye dissolves in the fluid and is carried to the end of the fluid path, 12, where it is visible through window 43.

20 Top layer 16 has an opening 60 for application of the sample. In the operation of the device, the sample delivery channel 18 fills with the sample. When the sample reaches the portion of the sample delivery channel of narrower size 92, capillary action drives the sample towards the sample circulation channel 19 and onto the membrane 1. Sample delivery channel cover 75, if
25 transparent, allows the operator to view the filling of the sample delivery channel and indicates when it is completely filled.

Sample is conducted from the sample delivery channel to the circulation channel and onto the membrane. As mentioned above, the sample circulation channel is configured to pass the
30 sample onto the membrane. The configuration of the sample circulation channel walls 21 and 22, and the fluid pathway defined on the membrane by, for example, printing with a special ink, maintains the sample in the fluid path.

As noted above, the instant device is suitable for measurement of one or more analytes using
35 immunoassay procedures as well as other procedures, including enzyme-based assays. The discussion herein refers to an immunoassay procedure by way of non-limiting example. As in the above discussion, the sample picks up the labeled detector antibody as it moves toward the capture channel, during which time analyte in the sample forms antibody-antigen complexes with the detector antibody. The sample, with the plasma front ahead of and separated from

5 the red blood cell front, reaches the capture zone wherein analyte, with bound labeled antibody, interacts with and forms a sandwich with capture antibody. Accumulation of labeled antibody at the capture zone indicates the presence of analyte in the sample. At the conclusion of the test, for example, when the test-end indicator window indicates that the test is complete, the operator observes in window for color at the capture zone(s). As noted above, 10 the labeled detector antibody, as well as other reagents, may be placed in the sample delivery channel.

As noted above, the sample delivery channel 18 is in operative communication with the sample circulation channel 19. Sample circulation channel 19 is shown in an arcuate configuration in 15 order to conform with the border 11 of the semicircular detection zone 3 of Fig. 31. Sample circulation channel 19 can be open or closed at both ends 20. It is formed with inner wall 21 and outer wall 22 and is surrounded by a capillary trap 23 which functions to assure that the flow of sample is into the detection zone 3 of Fig. 31 at all points of border 11, and then into the capture channel 6 at its entrance end 6a.

20 Figure 33 shows the detail of an example of a bottom piece 28 of the present invention. The bottom piece holds the membrane 1 in place, and may have tabs 66 and 68 as shown which correspond with notches in the top piece 16 to facilitate fitting the pieces together to hold the membrane in the correction position. Figure 4B shows a front view of the bottom piece 28 as 25 seen from the end with tabs 68, and Figure 33C a side view.

Figures 34A and 34B show the sample delivery channel cover piece, from top and front views, respectively. The notched end 62 represents the sample application area, as this end aligns with the end of the top piece 16 to form an opening, 60. The pointed end of the cover 30 represents the aspect which covers the portion of the sample delivery channel 18 which narrows to form a capillary channel 92 in communication with the sample circulation channel. The cover piece 75 is attached to the top piece 16 by sliding the cover piece into the top piece along the sample delivery channel, the angled extensions 64 in the sides of the cover piece 75 sliding into corresponding longitudinal groves 69 running along the inside walls of the sample 35 delivery channel in the top piece. Other means may be utilized in attaching the cover piece to the top piece, including adhesives, welding, etc.

Figures 35-36 show examples of other embodiments of the present invention, in particular, other positions for the sample delivery channel 18. Top views, bottom views, and longitudinal

5 sections are provided for two examples; views A show the top surface of the top pieces 16, views C the bottom surface of the top pieces 16, views B a longitudinal section of the top pieces 16, and views D the back pieces 28. In figure 35, the sample delivery channel is situated over the section of the device containing the membrane, permitting the device to have a reduced size. The sample application port 60 is on the side of the device. Figure 36 shows
10 a device with an extension from the membrane-holding portion of the device, providing a longer device with the sample application port 60 at the end of the device.

Fig. 38 (corresponding to Fig. 11 hereinabove) shows the configuration of a membrane 1 of the invention in which the biotin/streptavidin reaction is utilized to diagnose a whole blood
15 sample for the presence of three analytes. The design may be employed to ascertain the presence of several analytes such as myoglobin, troponin I or T and CK-MB in one small sample. The membrane 1 is formed with three distinct pathways, one for each analyte leading from the borders 11a, 11b and 11c of three separate detection zones 3a, 3b and 3c. The detection zones are separated by blocking segments 24. The whole operative area is
20 configured so as to provide three detection zones 3a, b and c in operative communications at their borders 11a, 11b and 11c with the sample circulation channel 19 on the lower surface of the upper layer 16 of the device. The detection zones 3a, 3b and 3c are in operative communication with the corresponding entrance ends 6a, 6b and 6c of the respective capture zone channels.

25 The detection zone 3a contains two labelled antibodies, e.g. a biotin labelled antibody to CK-MB and a gold labelled antibody to CK-MB.

Generally, in Fig. 37 black circles stand for gold labelled antibodies while open circles stand
30 for biotin labelled antibodies. No reference numerals are given for these detector antibodies in order not to clutter this figure.

As an example of the separation of the plasma from red blood cells during the operation of the device of Fig. 37, the red blood cell front in each of the three detection zones 3a, 3b, and 3c is
35 shown as 13a, 13b, and 13c, respectively; the location of the respective plasma fronts are shown as 14a, 14b, and 14c, respectively.

If CK-MB is present in the sample, the complex which forms will enter the capture channel at entrance 6a to ultimately react with streptavidin at the streptavidin line 7a to produce a visible

5 product.

Analogous reactions take place with other analytes such as troponin I or troponin T and with myoglobin in the separate pathways shown in the figure.

10 The same or other analytes may be similarly detected with conventional antigen antibody reactions. In addition to the sandwich-type immunoassay depicted in the above example, other immunoassay formats, including competitive assays, may be provided. Quantitation or semi-quantitation may be provided by utilizing various amounts of the different assay components. Furthermore, the device may carry out assays other than immunoassays. For
15 example, interaction of the analyte with an enzyme or a series of enzymes, in the presence of the appropriate co-factors and chromogenic substrate(s), may result in the generation of a color in the sample indicative of the presence of analyte in the sample. The color may be observed in the window 41.

20 While, as aforesaid, it is preferred to design the diagnostic devices of this invention to detect more than one analyte, it is possible to design them with a single capture channel and multiple capture lines, one for each analyte, or with a plurality of capture channels each with a single capture line. This latter design, however, is not preferred because of the need for increased sample volume to ensure that reactions will take place in all channels. This defeats a principle
25 aspect of the invention, namely to use the smallest sample with which it is possible to obtain useful results.

A compromise which to some extent, but not completely alleviates the problem is to make the channels as small as possible and design them to be as close as possible to each other. The
30 proximity of the channels, however, increases the difficulty of reading the results with confidence because it is difficult to distinguish a capture line in one channel from a capture line in another.

The devices of the invention can be configured to have more than one channel including the
35 test channel and/or a negative and positive control channel. Multiple channels may each have more than one capture line. The designs will be readily apparent to the skilled artisan.

One channel, usually the middle channel will contain only fixed antibodies to the suspected analyte(s). The positive control channel will contain mobile labeled antibodies at the entrance

5 to the channel and fixed antibodies deeper in the channel. The negative control channel will contain fixed antibodies, but will be blocked at its entrance to prevent the sample under test from entering. The negative test channel will be designed with an entrance hole through the support member to permit the addition of an analyte free material such as a buffer which will migrate to the capture antibodies.

10

The products and procedures of the invention, in addition to their value to test for cardiac analytes as described in detail above, may also be usefully employed in other medical procedures such as pregnancy and ovulation tests. They are especially useful to test for infections caused by particular viruses. For this utility they can be designed for both competitive and sandwich assays. They can be used to test for antigens, antibodies, surface

15

antigens, and virus particles such as gp120 of the AIDS virus.

Additionally, the products can be employed to test for drugs including drugs of abuse.

20

The reactions conducted in the various diagnostic procedures employed in the practice of this invention are generally well known to those skilled in the art. Most of them are ELISA tests conducted in a new and useful format. The advantages of this invention is that it provides new and useful formats on which the reactions can be conducted on small, hand-held instruments with speed and efficiency using low volumes of test liquids while concurrently

25

enabling the operator to have great confidence in the results.

30

Any of a variety of labels available to the skilled artisan may be utilized in the devices of this invention. Metal and enzyme labels are preferred. Metal labels are especially preferred due to their remarkable sensitivity. Amongst the metals, gold is most preferred principally because it is so widely employed for this type of reaction and its characteristics are so well understood. Additionally, a gold signal can be enhanced to become more readily visible by the use of a soluble silver salt and a reducing agent in accordance with known procedures. The gold label acts as a catalyst to reduce the silver salt to metallic silver, which deposits as a visible product. A typical reactive pair is silver lactate, which serves as the source of reducible silver ions, and

35

hydroquinone as a reducing agent. The metallic silver forms a readily discernible black deposit around each particle of gold.

The preferred particle size for gold labelled antibodies used in the invention is from about 35 to 65 nm, although appreciable variation can be tolerated depending on well understood

5 factors such as the concentration of the analyte and the affinity of the reactants.

If an enzyme label such as horseradish peroxidase is employed, reaction may be detected by the addition of hydrogen peroxide and a dye such as ortho phenylenediamine in accordance with standard procedures.

10

There may be a preincubation zone in the detection zone although it is not a necessary feature of the invention. The preincubation zone is employed to remove products present in the blood which may interfere with the desired reactions or make them difficult to detect. For example, if the device is to be used to detect cardiac analytes a typical interferant is the isoform of creatine kinase, CK-MM. Antibodies to the isoform CK-MB may cross react with CK-MM and give false readings. This can be avoided by providing sufficient immobilized antibody to CK-MM in a preincubation zone upstream of the mobile antibody for CK-MB so that all of the CK-MM is removed before the moving sample reaches the detection antibody.

15

20 The device employing the membrane of Figure 37 may utilize one or a plurality of labelled detector antibodies and capture antibodies in immobilized capture antibody lines. When several labelled detectors are employed care must be exercised to avoid interfering cross reactions. It is often best that the antibodies be arranged in more than one detection zone to react with their specific analytes as explained below in connection with the other figures.

25

The device of the present invention may also be prepared to employ the biotin/avidin reaction utilizing variations such as those described above. In the presently preferred variation as applied to the device, a biotin labelled antibody and a gold labelled antibody are movably placed in the detection zone 3, where each of them reacts with a different epitope on the analyte to form a ternary complex composed of biotin labelled antibody/analyte/gold labelled antibody which moves by capillary action into and through the capture channel zone 6 where it reacts with avidin or streptavidin to concentrate and form a detectable reaction product.

30

Of course, the antibodies employed in this invention may be either monoclonal or polyclonal. Similarly equivalents of the biotin/avidin reaction can be employed. All of the reagents mentioned herein may be replaced with equivalents and are illustrative but not limitations of the invention.

35

The skilled artisan will recognize that any porous substrate that chromatographically separates

5 red blood cells and plasma from whole blood may be employed in this invention. However, nitrocellulose is preferred because it is readily available at reasonable cost. Nitrocellulose has been employed in chromatography and related fields for so many years that scientists and technicians are familiar with its properties. Commercially available nitrocellulose sheets can be readily formed into any selected formation with any selected configuration of channels.

10

The nitrocellulose membranes of the invention may be characterized as sponge-like with a plurality of interconnected micropores of various sizes and dimensions giving rise to capillary forces within the membrane. This permits the biological fluid under investigation to move along the selected pathway.

15

For the separation of plasma from red blood cells in the practice of this invention, the area, geometry and dimensions of the various devices are so selected that the desired reactions take place in preselected areas as the liquid sample moves along predesigned pathways. For cardiac diagnosis of whole blood, these areas are selected on the basis of the relative speeds of the

20 fronts of the red blood cell stream and the plasma stream, the kinetics of the desired reactions, the affinity of the antibodies for their respective epitopes and other factors which are well known to the skilled artisan or readily determined by conventional testing procedures.

25

Although Figure 37 shows the configuration of a porous membrane with three fluid pathways, for use with three analytes, a single fluid pathway with three capture zones may also be provided, and as noted above, is preferred.

30

One of the advantages of this invention is that the devices whether intended to measure one, two or three antigens can have the same dimensions. Of course, the porous carrier layer 1 will be designed differently in each case. However, the top layer 16 does not require any changes to fit differently designed carrier layers 1.

35

It will be seen that what has been described is a device and method which permits the detection of components in a liquid sample, for example cardiac analytes in whole blood, serum or plasma, by antigen/antibody reactions utilizing enzyme or direct labels in competitive or sandwich assays. In the devices of the invention, the reactants move along a pathway formed by successive interconnected channels in different planes of the support members and the membrane.

5 While the foregoing descriptions show the one or more antibodies moveably deposited in detection zone 3, alternate locations for the detector antibodies as well as other reagents are embraced within the present invention. The detector antibody may be provided in the form of, for example, lyophilized beads, such as a single larger bead or multiple smaller beads, placed within the fluid path upstream from the membrane, such that the bead dissolves in the fluid.

10

The bead may be provided in a sample delivery channel, the sample circulation channel, or at their junction; a small cavity may be provided in the sample delivery channel or at the junction between the sample delivery channel 18 and the sample circulation channel 19, to hold the material. In another embodiment, the antibody is deposited in lyophilized form within the channel. Other reagents may be so provided, such as reagents to remove interfering substances, as described above. Furthermore, in a device with more than one fluid path in the membrane for carrying out more than one assay, reagents common to the assays may be provided in the fluid path prior to the membrane, and reagents specific to each assay provided in the particular detection zone of the membrane as described above. These various configurations are embraced within the present invention.

20

While a variety of nitrocellulose materials are available in various cell sizes, the presently preferred porous carriers are those which, if used as a filter, that is filtering particles from a liquid stream flowing vertically to the horizontal surface of the membrane, will prevent the passage of particles larger than from 3 to 12 μm . In the practice of the invention, membranes with a pore size from about 5 to 12 μm , preferably 3 to 8 μm , are preferred. Some variation is possible. However, as the pore size decreases, the mobility of a fluid within the membrane decreases, thereby increasing the time required for diagnosis. If the pores are too large, the time of passage reduces with the result that the reactants are not in contact with each other for a sufficient period for the diagnostic reactions to occur, or to occur to such a limited extent that they do not provide the desired information.

25

30

Nitrocellulose membranes with supporting polyester or other films are commercially available. These are preferred for use in this invention since unsupported membranes tend to be quite fragile, susceptible to fracture and difficult to handle in a mass production environment. Moreover, the films are impervious to the flowing fluids so that they do not interfere with the flow of liquid samples through the chosen pathways of the devices of this invention. One such membrane is available to a variety of pore sizes from Gerbermembrane of Gerbershausen, Germany.

35

5

The antibodies employed in this invention are prepared by standard techniques. See for example, Falfre, Howe, Milstein et al., Nature Vol. 266, 7, 550-552, April 1977. The pertinent disclosure of this seminal article on the preparation of monoclonal antibodies is incorporated herein by reference.

10

Procedures for fixing antibodies to substrates such as nitrocellulose are known and usable in producing the devices of this invention. Nitrocellulose is an avid binder for proteins. Hence, the immobile capture antibody need only be applied into the capture zone in a predetermined area. The labelled detector antibody may be movably affixed to the membrane by first saturating the detector zone with another protein such as bovine serum albumin. Alternate locations for the detector antibodies are noted above. As depicted in Figures 38A-38B, a cavity 100 is provided at the junction between the sample delivery channel and the sample circulation channel to contain a bead or other form of reagents such as lyophilized labeled detector antibody, which will dissolve in the fluid to be analyzed as it passes through this region of the device. Figure 38A also shows a test end indicator window 43 and a corresponding strip of reagent on the membrane just upstream from this window. The fluid dissolves and carries this reagent into view of window 43 to indicate the test is finished.

In another embodiment shown in Figure 39, the detector antibody at position 100 is present in the sample delivery channel. Figures 40A-40B and 41A-41B show other variations in the design of the device to comprise a cavity to contain reagents in dried or bead form, in particular, a concavity. As noted above, the reagents provided in the fluid path may include labeled detector antibody(ies) as well as other reagents needed to perform the test, including those needed to remove interfering substances that may be present in the sample. Reagents may be provided both on the membrane and in the fluid path, as needed. Various combinations will be understood by the skilled artisan to provide operable assays for the selected analyte(s). When the sample used in the assay is whole blood, and separation of red blood cells from the plasma is desired, the reagents provided in the device must not cause lysis of the red blood cells in the sample, to permit the separation.

35

The device of this invention can be readily manufactured by procedures already well known in the art.

As mentioned above, other assay procedures may be performed using the device of the present

5 invention and its disclosed modifications. This includes both qualitative and quantitative assays, both immunoassays and non-immunoassay formats. Enzyme-based assays, such as the quantitation of glucose in whole blood using the combination of glucose oxidase and peroxidase, with the appropriate reactants and chromogenic substrate to generate a color in proportion to the level of glucose in the sample, may be configured to operate using a device
10 of this invention. The skilled artisan will recognize the adaptability of other assay formats to the present device.

The following non limiting examples are given by way of illustration only.

15

EXAMPLE 1

Whole Blood CK-MB Test

20 1A) On a polyester supported cellulose nitrate membrane (3 μm nominal pore size from Gerbermembrane GmbH, Gerbershausen, Germany), a contour as in Fig. 4, is drawn with a Paint Marker 751 yellow (from Edding AG, Ahrensburg, Germany). A capture line is prepared with a 13 mg/ml aqueous streptavidin solution (Streptavidin, poly, from Microcoat GmbH, Benried, Germany). A control line is prepared with a solution containing 80 μl of a 4% (w/v)
25 solution of sucrose (from Sigma-Aldrich GmbH, Steinheim, Germany), 10 μl of water and 10 μl of a 1 mg/ml solution of recombinant CK-MB (from Spectral Diagnostics, Toronto, Canada). After drying, the membrane is impregnated with a blocking solution containing in final concentrations: 0.06% (w/w) Octyl-beta-D-Gluco-pyranoside (from Fluka Chemie AG, Buchs, Switzerland), 1:30 dilution of Kasein-Bindemittel (from H. Schmincke & Co., Erkrath,
30 Germany) and 30 mM 1,4-Piperazinediethanesulfonic acid (from Sigma-Aldrich GmbH, Steinheim, Germany) with a final pH of 6.2. After drying, 2.7 μl of a gold-conjugate solution and 2 μl of a biotinylated antibody solution is applied and the membrane is dried again. The gold-conjugate solution and 2 μl of a biotinylated antibody solution are applied and the membrane is dried again. The gold-conjugate solution is prepared with a 40 nm gold sol
35 loaded with 22 $\mu\text{g/ml}$ of the antibody 5CKMB-6 from Spectral Diagnostics, Toronto, at an OD (520 nm) of 10 prepared by British Biocell International, Cardiff, UK. To 45 μl of this gold-conjugate (OD 10) 45 μl of water and 10 μl of a 2.5% (w/v) aqueous solution of Crotein C (from Croda Chemicals Ltd., UK) is added and mixed. The biotinylated antibody solution is prepared with the antibody 1rCKMB-28 from Spectral Diagnostics, Toronto as described to

60

5 57 μ l of water 20 μ l of a 6% (w/v) aqueous solution of Crotein C and 3 μ l of a 2 mg/ml stock solution of the biotinylated antibody solution are added and mixed.

1B) For comparison, tests are prepared as in 1A) but without the biotinylated antibody solution, and instead of the streptavidin capture line an antibody capture line is prepared with
10 the antibody IrCKMB-28 (from Spectral Diagnostics, Toronto) at a concentration of 13 mg/ml.

Heparinized whole blood is spiked with rCKMB at indicated concentrations and 28 μ l are applied to the test. The results (within 6-7 min.) are as follows:

15

rCKMB in ng/ml	Streptavidin- Capture	Antibody- Capture
0	-	-
5	+	n.d.
20	++	n.d.
80	++++	+

- = no visible signal line

++++ = strong signal line

n.d. = not determined

20

All control lines are positive.

EXAMPLE 2

25

Comparison Semicircular to Rectangular CK-MB Test

To demonstrate the versatility of the concept the sample entry in a semicircular area (circle segment) (Figs. 4 and 5) is compared with a sample entry in a rectangular configuration, i.e. from 3 sides (Figs. 9 and 10). The test areas (contour areas) are in both cases the same.

30

Beside the contour shape and blood entry directions all other procedures are as in example 1A).

		61			
rCKMB		circle segment	rectangular		
5	in ng/ml	signal	test time	signal	test time
	0	-	6.5 min.	-	7.5 min.
	20	++	7.0 min.	++	7.5 min.

EXAMPLE 3

10 Semicircular Area - Three Analytes - One Detection Zone

A test as in example 1B) is prepared, but in addition to the CKMB antibody capture line there is a TNI antibody capture line and a Myoglobin antibody capture line.

TNI capture: 13 mg/ml polyclonal goat TNI

15 CKMB capture: 13 mg/ml 1rCKMB-28

Myoglobin capture: 13 mg/ml polyclonal rabbit Myoglobin

All antibodies are from Spectral Diagnostics, Toronto.

Gold-conjugates for the 3 analytes are from British Biocell Intern., Cardiff, UK:

TNI-gold-a: 40 nm gold sol loaded with 8 µg/ml 81-7 antibody (OD 10)

20 TNI-gold-b: 40 nm gold sol loaded with 16 µg/ml 21-14 antibody (OD 10)

Myoglobin-gold: 15 nm loaded with 90 µg/ml 2Mb-295 antibody (OD 10)

CKMB-gold: 40 nm gold sol loaded with 22 µg/ml 5CKMB-6 (OD 10)

All antibodies are from Spectral Diagnostics, Toronto

The TNI gold conjugate solution contains: 15 µl of TNI-gold-a at an OD of 33, 30 µl of TNI-gold-b at an OD of 33, 45 µl water and 10 µl of a 2.5% (w/v) aqueous solution of Crotein C.

2.7 µl of this solution is applied to the test area.

The CKMB/Myoglobin gold conjugate solution contains: 48 µl of CKMB-gold at an OD of 33, 25 µl of Myoglobin-gold at an OD of 6, 17 µl water and 10 µl of a 2.5% aqueous solution of Crotein C. 2 µl of this solution is applied to the test area.

30

Heparinized whole blood is spiked with rCKMB, TNI and Myoglobin at indicated concentrations, and 28 µl are applied to the test. The results are as follows:

<u>Signal</u>		
TNI-capture	CKMB-capture	Myoglobin-capture

62

0 ng/ml TNI	-		
0 ng/ml CKMB		-	
0 ng/ml Myoglobin			trace
2 ng/ml TNI	+		
20 ng/ml CKMB		+	
200 ng/ml Myoglobin			++

5

Trace: even unspiked blood from a healthy subject can contain trace amounts of myoglobin

EXAMPLE 4

10

Semicircular Area - Three Analytes - Three Detection Zones

For more than one analyte with high sensitivity a contour as in Fig. 11 is used. The capture lines are prepared with streptavidin (13 mg/ml) as in Example 1A (the blocking procedure likewise). In this example the contour is drawn with Paint Marker 780 white (from Edding
15 AG, Ahrensburg, Germany).

All gold sol-conjugates are prepared by British Biocell International, Cardiff, UK. All antibodies are from Spectral Diagnostics, Toronto.

20 TNI-gold conjugate: The following solutions are mixed:

18 μ l gold conjugate A with an OD of 55 (50 nm gold sol loaded with 18 μ g/ml of the antibody 81-7 at OD 10), 36 μ l gold conjugate B with an OD of 55 (60 nm gold sol loaded with 10 μ g/ml of the antibody 21-14 at OD 10), 36 μ l water and 10 μ l of a 2.5% (w/v) aqueous solution of Crotein C. 1.8 μ l is applied to the test area.

25 Biotinylated TNI-antibodies: The following solutions are mixed: 67 μ l water, 25 μ l of a 6% (w/v) aqueous solution of Crotein C, 3.5 μ l of a 1 mg/ml stock solution of biotinylated goat TNI antibodies and 5 μ l of a 27.6 mg/ml solution of Chrom Pure Goat IgG (from Jackson Immuno Research Laboratories Inc.). 2.1 μ l of this solution is applied to the test area.

30 CKMB-gold conjugate: As in example 1A), except that the OD of the stock solution is 33, and 1.1 μ l of the mixture is applied.

Biotinylated CKMB-antibodies: As in example 1A), except that 1.4 μ l is applied.

Myoglobin-gold conjugate: The following solutions are mixed: 17 μ l of a gold conjugate with

63

5 an OD of 6 (15 nm gold sol loaded with 90 $\mu\text{g/ml}$ of the antibody 2Mb-295 at OD 10), 73 μl water and 10 μl of a 2.5% (w/v) aqueous solution of Crotein C. 0.8 μl of this mixture is applied to the test.

10 Biotinylated Myoglobin-antibodies: The following solutions are mixed: 45 μl water, 25 μl of a 6% (w/v) aqueous solution of Crotein C and 30 μl of a 1 mg/ml stock solution of biotinylated rabbit antibodies Myoglobin. 0.5 μl of this mixture is applied to the test.

Heparinized whole blood is spiked with rCKMB, TNI and Myoglobin at indicated concentrations, and 70 μl is applied to the test.

The results (within 10 to 12 min.) are as follows:

15

		<u>Signal</u>	
	TNI	CKMB	Myoglobin
0 ng/ml TNI	-		
0 ng/ml CKMB		-	
0 ng/ml Myoglobin			-
2 ng/ml TNI	++		
20 ng/ml CKMB		++	
200 ng/ml Myoglobin			++

10 ng/ml TNI	++++		
100 ng/ml CKMB		++++	
700 ng/ml Myoglobin			++++

20 It is to be understood that the invention is not limited to the illustrations described and shown herein which are deemed to be merely illustrative of the best modes of carrying out the invention and which are susceptible of modifications of form, size, arrangement of parts and details of operation without departing from the spirit or scope of the invention. The invention, rather, is intended to encompass all such modifications which are within the spirit and scope of the claims.

25

5

WHAT IS CLAIMED IS:

- 10 1. An analytical test device for determining the presence of at least one analyte in a fluid sample, said device comprising:
- a dry porous carrier;
- 15 at least one detection zone covering at least a segment of an area of said carrier, the sample being permitted to enter into said detection zone from a plurality of different directions;
- 20 at least one capture zone channel having an entrance end which is in operative communication with the detection zone to permit sample to flow from the detection zone into the capture zone channel, the distances between all points where the sample is permitted to enter the detection zone and said entrance end being essentially the same.
- 25 2. The device of claim 1 containing reagents required for reactions determinative of the analyte.
- 30 3. An analytical test device for determining the presence of at least one analyte in a fluid sample, said device comprising:
- a dry porous carrier through which a sample can flow by capillary action;
- a sample delivery means through which the sample can be applied to the device and flow thereinto;
- 35 a sample circulation channel which is closed at its terminal ends and which circumscribes an area of the carrier;
- at least one detection zone covering at least a segment of said area of the carrier, wherein at least a segment of the sample circulation channel conforms with a border of

5 the detection zone and is in operative communication with said detection zone, across
which border the sample is permitted to enter into the detection zone simultaneously
from a plurality of different directions and to form a stream flowing away from said
border, the detection zone containing at least one mobile, labelled specific binding
10 reagent for the at least one analyte, which said at least one binding reagent is capable
of reacting with said at least one analyte to form at least one labelled complex which is
capable of moving along with said stream; and

at least one capture zone channel having an entrance end and a closed terminal end, the
entrance end being in operative communication with the detection zone to permit said
15 stream to flow from the detection zone into the capture zone channel, the distances
between all points of said border and said entrance end being essentially the same, the
capture zone channel containing at least one immobilized specific binding reagent,
which at least one binding reagent is capable of reacting with and concentrating said at
least one labelled complex to form at least one detectable reaction product.

20

4. The device of claim 1 or 3 wherein the analyte is selected from troponin I, troponin T,
myoglobin, CK-MB and mixtures thereof.

25

5. The device of claim 1 or 3 wherein the analyte is selected from hCG, LH and mixtures
thereof.

6. The device of claim 1 or 3 wherein the fluid sample is selected from whole blood,
plasma, serum and urine.

30

7. The device of claim 1 or 3 wherein the dry porous carrier is nitrocellulose.

8. The device of claim 1 or 3 comprising two or more detection zones arranged on said
area of the carrier, there being an equal number of capture zone channels, each of
which being in operative communication with a corresponding detection zone.

35

9. The device of claim 3 wherein the sample circulation channel is arcuate and said area is
semicircular.

10. The device of claim 1 or 3 wherein said area is polygonal or forms part of a polygon.

5

11. An analytical test device suitable for determining the presence of at least one antigen contained in a low volume of a liquid biological sample while permitting rapid and efficient flow of the sample through at least one defined pathway in which reactions determinative of the antigen take place, said device comprising:

10

a top layer having an upper surface formed with a through hole for the addition of the sample, the through hole being in registry with a sample delivery channel formed in the lower surface of the top layer and in operative communication with a sample circulation channel closed at its terminal ends and formed with inner and outer walls to define a pathway for the sample in the lower surface of the top layer, the inner walls of the circulation channel defining an indent in the lower surface of the top layer;

15

a support layer attached to the top layer;

20

a dry porous carrier layer through which the sample can flow by capillary action sandwiched between the upper and lower layers, the porous carrier layer being configured to contain at least one detection zone having a border in operative communication with a segment of the sample circulation channel and a second opposite end in operative communication with a capture zone channel having an entrance end and a closed terminal end thereby to provide a conduit through which the liquid sample may flow by capillary action from the sample circulation channel to the terminal end of the capture zone channel;

25

the delivery channel, circulation channel, detection zone and capture zone channel forming a defined pathway through which the liquid sample flows from the through hole to the terminal end of the capture channel;

30

there being at least one mobile, labelled reagent which will specifically react with the antigen in the detection zone to form a labelled complex which will move by capillary action into the capture zone channel; and

35

there being immobilized reagent in the capture zone channel which will react with and concentrate the labelled complex to form a detectable reaction product.

- 5 12. The device of claim 11 in which the sample circulation channel is arcuate.
13. The device of claim 11 in which the liquid biological sample is selected from whole blood, plasma, serum and urine.
- 10 14. The device of claim 11 wherein the antigen is selected from troponin I, troponin T, myoglobin, CK-MB and mixtures thereof.
15. The device of claim 11 wherein the antigen is selected from hCG, LH and mixtures thereof.
- 15 16. The device of claim 11 wherein the upper layer is transparent and the detectable reaction product is visible.
17. The device of claim 11 wherein the upper layer is opaque and has a view window
20 through which the detectable reaction product is visible.
18. The device of claim 11 wherein, in the detection zone, there is a mixture of a mobile labelled antibody which will react with one epitope on the analyte and a mobile biotin labelled antibody which will react with another epitope on the analyte, and the
25 immobilized reagent is selected from the group consisting of streptavidin and avidin.
19. The device of claim 11 wherein the label is a particulate direct label.
20. The device of claim 19 wherein the label is a gold label.
- 30 21. The device of claim 11 in which the dry porous carrier is nitrocellulose.
22. The device of claim 11 wherein said at least one antigen is a cardiac analyte and said liquid biological sample is whole blood, the dry porous carrier causing red blood cells
35 to separate chromatographically from the plasma to cause the formation of a plasma front moving in the capture zone channel and a red blood cell front upstream thereof, the major portion of the labelled complex being between the red blood cell front and the plasma front so that the labelled complex is substantially free of red blood cells when it encounters the immobilized reagent to form the detectable reaction product.

5

23. The device of claim 22 wherein the mobile reagent in the detection zone is a labelled antibody which will react with one epitope on the analyte and the immobilized reagent is an antibody which will react with another epitope on the analyte.

10

24. The device of claim 22 wherein, in the detection zone, there is a mixture of a mobile labelled antibody which will react with one epitope on the analyte and a mobile biotin labelled antibody which will react with another epitope on the analyte, and the immobilized reagent is an avidin.

15

25. The device of claim 22 containing the reagents for determining the presence of troponin I or troponin T.

20

26. The device of claim 22 containing two pathways, one containing the reagents for determining the presence of myoglobin, the other containing the reagents for determining the presence of CK-MB.

25

27. The device of claim 22 containing three pathways, the first pathway containing the reagents for determining the presence of troponin I or troponin T, the second pathway containing the reagents for determining the presence of myoglobin and the third pathway containing the reagents for determining the presence of CK-MB.

28. The device of claim 22 in which the first pathway contains only the reagents for determining the presence of troponin I.

30

29. The device of claim 22 in which there is only one pathway and it contains the reagents for determining the presence of myoglobin and CK-MB.

35

30. The device of claim 22 in which there is only one pathway and it contains the reagents for determining the presence of troponin I or troponin T together with the reagents for determining the presence of myoglobin and CK-MB.

31. A method for determining the presence of at least one analyte in a fluid sample comprising the sequential steps of:

- i) providing a dry porous carrier through which sample can flow by capillary

- 5 action;
- 10 ii) providing at least one detection zone covering at least a segment of an area of said carrier, such that said sample is permitted to enter into said detection zone from a plurality of different directions, and said detection zone containing at least one mobile, labelled binding reagent for said at least one analyte, which binding reagent is capable of reacting with said analyte to form a labelled complex;
- 15 iii) providing at least one capture zone channel having an entrance end which is in operative communication with the detection zone to permit sample to flow from the detection zone into the capture zone channel, the distances between all points where said sample is permitted to enter said detection zone and said entrance end being essentially the same, said capture zone channel containing immobilized specific binding reagent, which binding reagent is capable of reacting and concentrating said labelled complex to form a detectable reaction product;
- 20 iv) applying a quantity of said fluid sample to said detection zone;
- v) permitting a sufficient period of time to elapse for the fluid sample to flow from the detection zone from said plurality of different directions to the capture zone channel and any said analyte therein to form a detectable reaction product at said capture zone;
- 25 vi) identifying the presence of said at least one analyte in said fluid sample by detecting any said detectable reaction product at said capture zone.
32. The method of claim 31 wherein said at least one analyte is a cardiac analyte.
33. The method of claim 32 wherein three pathways are provided for identifying the presence of troponin I or troponin T together with identifying the presence of myoglobin and CK-MB.
- 30 34. The method of claim 33 wherein there is only one pathway provided for identifying the presence of troponin I or troponin T together with the identifying the presence of myoglobin and CK-MB.
- 35 35. An analytical test device suitable for determining the presence of at least one analyte contained in a low volume of a liquid biological sample while permitting rapid and efficient flow of the sample through at least one defined pathway in which reactions

5 determinative of the analyte take place, said device comprising:

10 a top layer having an upper surface formed with a through hole for the addition of the sample, said through hole being in registry with a sample delivery channel formed in the lower surface of the top layer, said sample delivery channel having walls defined by said lower surface of said top layer and an upper surface of a bottom layer, said sample delivery channel in operative communication with a sample circulation channel closed at its terminal ends and formed with inner and outer walls to define a pathway for the sample in the lower surface of the top layer, the inner walls of the circulation channel defining an indent in the lower surface of the top layer;

15 the bottom layer attached to the top layer, said dry porous carrier therebetween in contact with said walls of said sample circulation channel and providing a fluid pathway therefrom;

20 said fluid pathway of said dry porous carrier layer configured to contain at least one detection zone having a border in operative communication with the sample circulation channel, the sample being permitted to enter into said detection zone from said sample circulation channel from a plurality of different directions; and an opposite end in operative communication with a capture zone channel having an entrance end and a closed terminal end to provide a conduit through which the liquid sample may flow by capillary action from the sample circulation channel to the terminal end of the capture zone channel, the distances between all points where the sample is permitted to enter the detection zone and said entrance end being essentially the same;

30 the sample delivery channel, sample circulation channel, detection zone and capture zone channel forming a defined pathway through which the liquid sample flows from the through hole to the terminal end of the capture channel;

35 there being immobilized reagent in the capture zone channel which will react with said analyte to form a detectable product.

36. The device of claim 35 in which the sample circulation channel is arcuate.

37. The device of claim 35 in which the liquid biological sample is selected from whole

- 5 blood, plasma, serum and urine.
38. The device of claim 35 wherein the analyte is selected from myoglobin, CK-MB, either troponin I or troponin T, and combinations thereof.
- 10 39. The device of claim 35 wherein the analyte is selected from hCG, LH and the combination thereof.
40. The device of claim 35 wherein the top layer is transparent and the detectable reaction product is visible.
- 15 41. The device of claim 35 wherein the top layer is opaque and has a view window or transparency through which the detectable reaction product is visible.
42. The device of claim 35 wherein a mobile labeled reagent is provided, said reagent is a
20 labelled antibody which will react with one epitope on the analyte and the immobilized reagent is an antibody which will react with another epitope on the analyte.
43. The device of claim 42 comprising a mixture of a mobile labelled antibody which will react with one epitope on the analyte and a mobile biotin labelled antibody which will
25 react with another epitope on the analyte, and the immobilized reagent is an avidin.
44. The device of claim 43 wherein the immobilized reagent is selected from the group consisting of streptavidin and avidin.
- 30 45. The device of claim 35 wherein the label is a particulate direct label.
46. The device of claim 35 wherein the label is a gold label.
47. The device of claim 35 in which the dry porous carrier is nitrocellulose.
- 35 48. The device of claim 42 wherein said mobile reagent is provided in the detection zone.
49. The device of claim 42 wherein said mobile reagent is provided in the fluid path prior to the membrane.

- 5
50. The device of claim 35 containing two pathways, one containing the reagents for determining the presence of myoglobin, the other containing the reagents for determining the presence of CK-MB.
- 10 51. The device of claim 35 containing three pathways, the one pathway containing the reagents for determining the presence of troponin I or troponin T, another pathway containing the reagents for determining the presence of myoglobin and still another pathway containing the reagents for determining the presence of CK-MB.
- 15 52. The device of claim 35 containing the reagents for determining the presence of troponin I.
53. The device of claim 35 in which there is only one pathway and it contains the reagents for determining the presence of myoglobin and CK-MB.
- 20 54. The device of claim 35 in which there is only one pathway and it contains the reagents for determining the presence of troponin I or troponin T together with the reagents for determining the presence of myoglobin and CK-MB.
- 25 55. The device of claim 35 wherein a window is provided at the junction between said sample delivery channel and said sample circulation channel to indicate that sufficient sample has been added to said sample delivery channel to conduct said determining of at said at least one analyte.
- 30 56. The device of claim 35 wherein said sample delivery channel has a predetermined capacity corresponding to the volume of sample needed to conduct said determining of said at least one analyte, said sample delivery channel having means for conducting said predetermined volume of sample from said sample delivery channel to said sample circulation channel when said sample delivery channel is filled with said predetermined
- 35 volume.
57. The device of claim 56 wherein the portion of said sample delivery channel in operative communication with said sample circulation channel comprises a narrowed capillary portion leading to said sample circulation channel, wherein when the sample delivery

5 channel is filled with said sample to the point of contact with said narrowed capillary portion, said sample is conducted to the sample circulation channel.

10 58. An analytical test device suitable for determining the presence of at least one analyte contained in a low volume of a liquid biological sample while permitting rapid and efficient flow of the sample through at least one defined pathway in which reactions determinative of the analyte take place, said device comprising:

15 a top layer having an upper surface formed with a through hole for the addition of the sample, said through hole being in registry with a sample delivery channel formed in the upper surface of the top layer, said sample delivery channel in operative communication with a sample circulation channel closed at its terminal ends and formed with inner and outer walls to define a pathway for the sample in the lower surface of the top layer, the inner walls of the circulation channel defining an indent in
20 the lower surface of the top layer;

a bottom layer attached to the top layer, said bottom layer and top layer holding a dry porous carrier therebetween, said dry porous carrier having a fluid pathway;

25 said fluid pathway of said dry porous carrier layer configured to contain at least one detection zone having a border in operative communication with a segment of the sample circulation channel and an opposite end in operative communication with a capture zone channel having an entrance end and a closed terminal end thereby to provide a conduit through which the liquid sample may flow by capillary action from
30 the sample circulation channel from a plurality of different directions onto the porous carrier and to the entrance of the capture zone channel, into the capture zone channel, to the terminal end of the capture zone channel; the distances between all points where the sample is permitted to enter the detection zone and said entrance end being essentially the same; and

35 the delivery channel, circulation channel, detection zone and capture zone channel forming a defined pathway through which the liquid sample flows from the through hole to the terminal end of the capture channel;

- 5 there being immobilized reagent in the capture zone channel which will react with said analyte to form a detectable product.
59. The device of claim 58 further comprising at least one mobile, labelled reagent which will specifically react with the analyte to form a labelled complex which will move by
10 capillary action into the capture zone channel; and there being immobilized reagent in the capture zone channel which will react with and concentrate the labelled complex to form a detectable reaction product.
60. The device of claim 58 in which the sample circulation channel is arcuate.
15
61. The device of claim 58 in which the liquid biological sample is selected from whole blood, plasma, serum and urine.
62. The device of claim 58 wherein the analyte is selected from myoglobin, CK-MB either
20 troponin I or troponin T, and combinations thereof.
63. The device of claim 58 wherein the analyte is selected from hCG, LH and mixtures thereof.
- 25 64. The device of claim 59 wherein the mobile reagent in the detection zone is a labelled antibody which will react with one epitope on the analyte and the immobilized reagent is an antibody which will react with another epitope on the analyte.
65. The device of claim 59 comprising a mixture of a mobile labelled antibody which will
30 react with one epitope on the analyte and a mobile biotin labelled antibody which will react with another epitope on the analyte, and the immobilized reagent is an avidin.
66. The device of claim 59 wherein, the immobilized reagent is selected from the group
35 consisting of streptavidin and avidin.
67. The device of claim 58 wherein the label is a particulate direct label.
68. The device of claim 58 wherein the label is a gold label.

- 5 69. The device of claim 58 in which the dry porous carrier is nitrocellulose.
70. The device of claim 58 containing the reagents for determining the presence of troponin I or troponin T.
- 10 71. The device of claim 58 containing two pathways, one containing the reagents for determining the presence of myoglobin, the other containing the reagents for determining the presence of CK-MB.
- 15 72. The device of claim 58 containing three pathways, the one pathway containing the reagents for determining the presence of troponin I or troponin T, another pathway containing the reagents for determining the presence of myoglobin and still another pathway containing the reagents for determining the presence of CK-MB.
- 20 73. The device of claim 58 in which contains only the reagents for determining the presence of troponin I.
74. The device of claim 58 in which there is only one pathway and it contains the reagents for determining the presence of myoglobin and CK-MB.
- 25 75. The device of claim 58 in which there is only one pathway and it contains the reagents for determining the presence of troponin I or troponin T together with the reagents for determining the presence of myoglobin and CK-MB.
- 30 76. The device of claim 58 wherein said sample delivery channel has a predetermined capacity corresponding to the volume of sample needed to conduct said determining of said at least one analyte, said sample delivery channel having means for conducting said predetermined volume of sample from said sample delivery channel to said sample circulation channel when said sample delivery channel is filled with said predetermined volume.
- 35 77. The device of claim 76 wherein the portion of said sample delivery channel in operative communication with said sample circulation channel comprises a narrowed capillary portion leading to said sample circulation channel, wherein when the sample delivery channel is filled with said sample to the point of contact with said narrowed capillary

WO 00/08466

PCT/EP99/05712

76

- 5 portion, said sample is conducted to the sample circulation channel.
78. The device of claim 58 wherein a dried reagent is present in said sample delivery channel.
- 10 79. The device of claim 78 wherein said reagent is selected from the group consisting of a labeled antibody to said analyte, a biotinylated antibody to said analyte, and the combination thereof.

FIG. 1

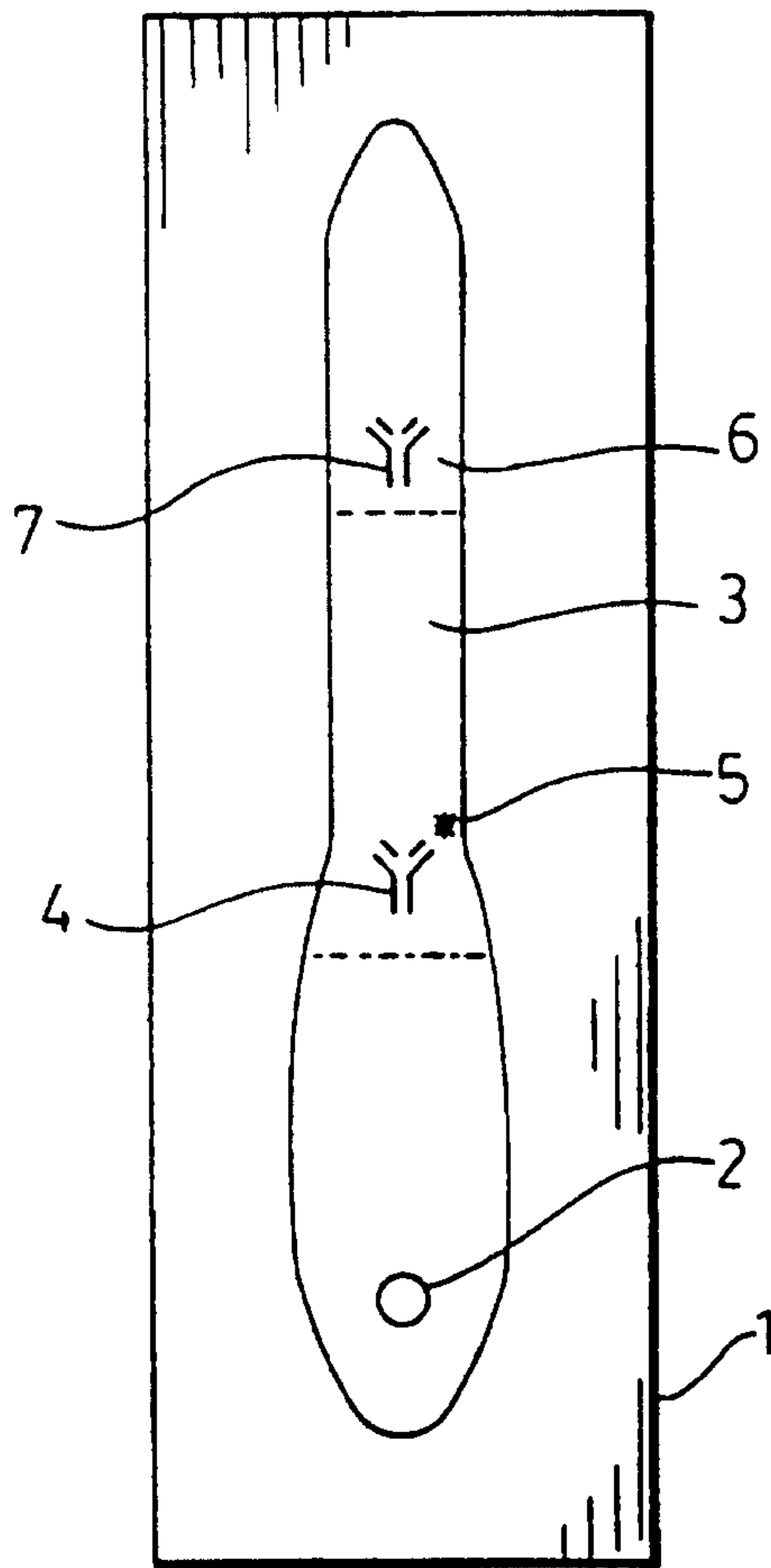

FIG. 2

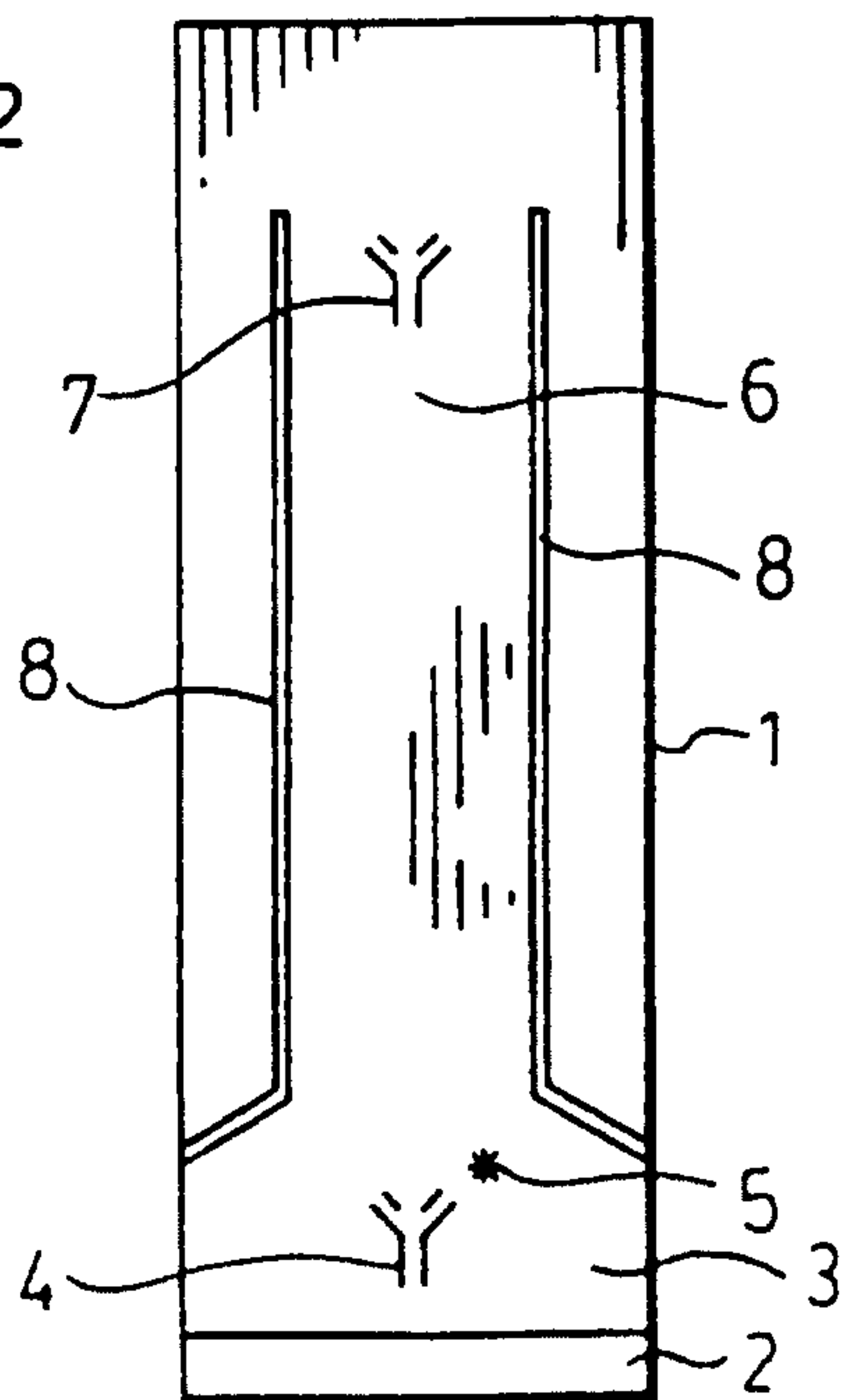
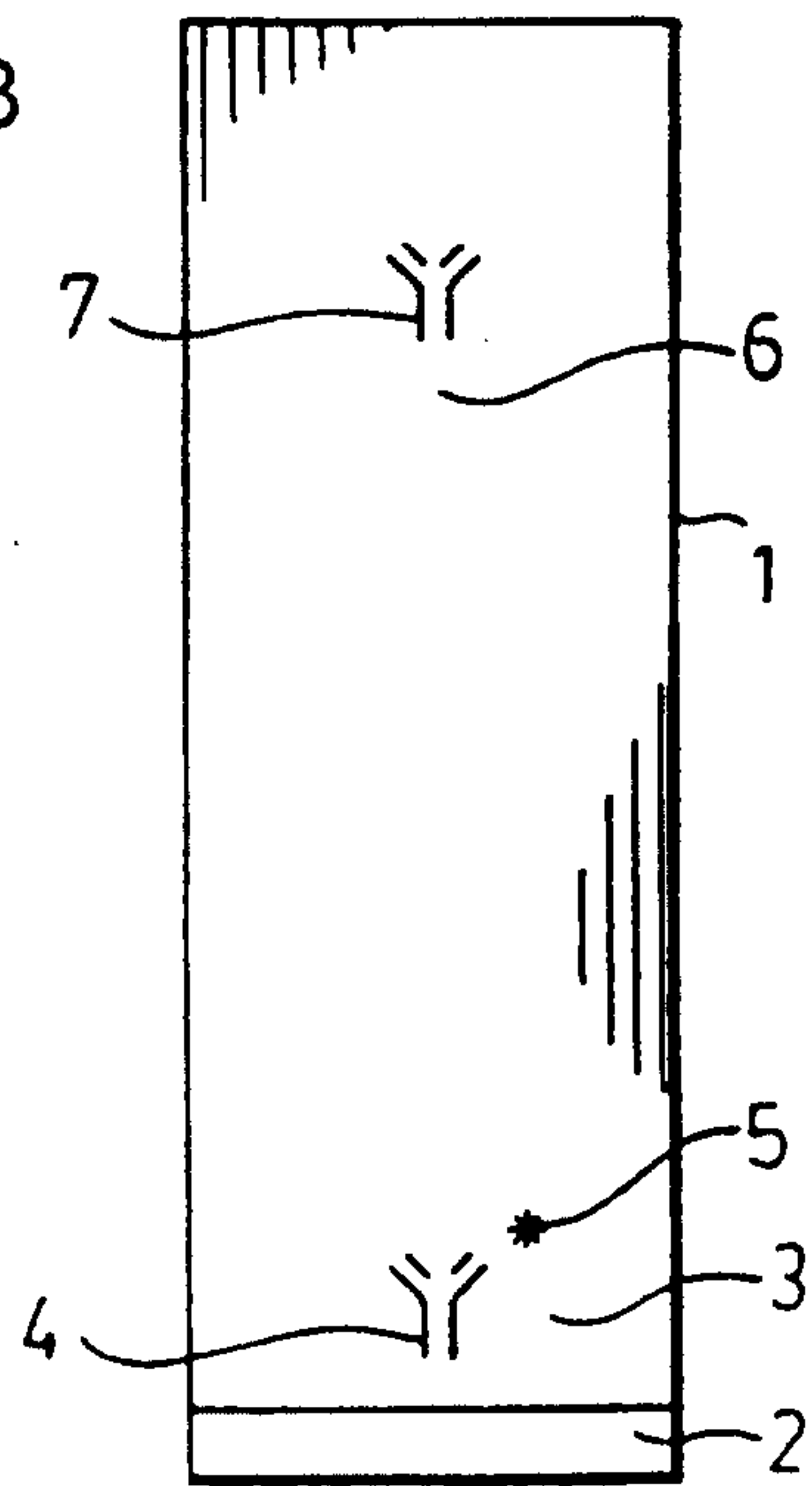

FIG. 3



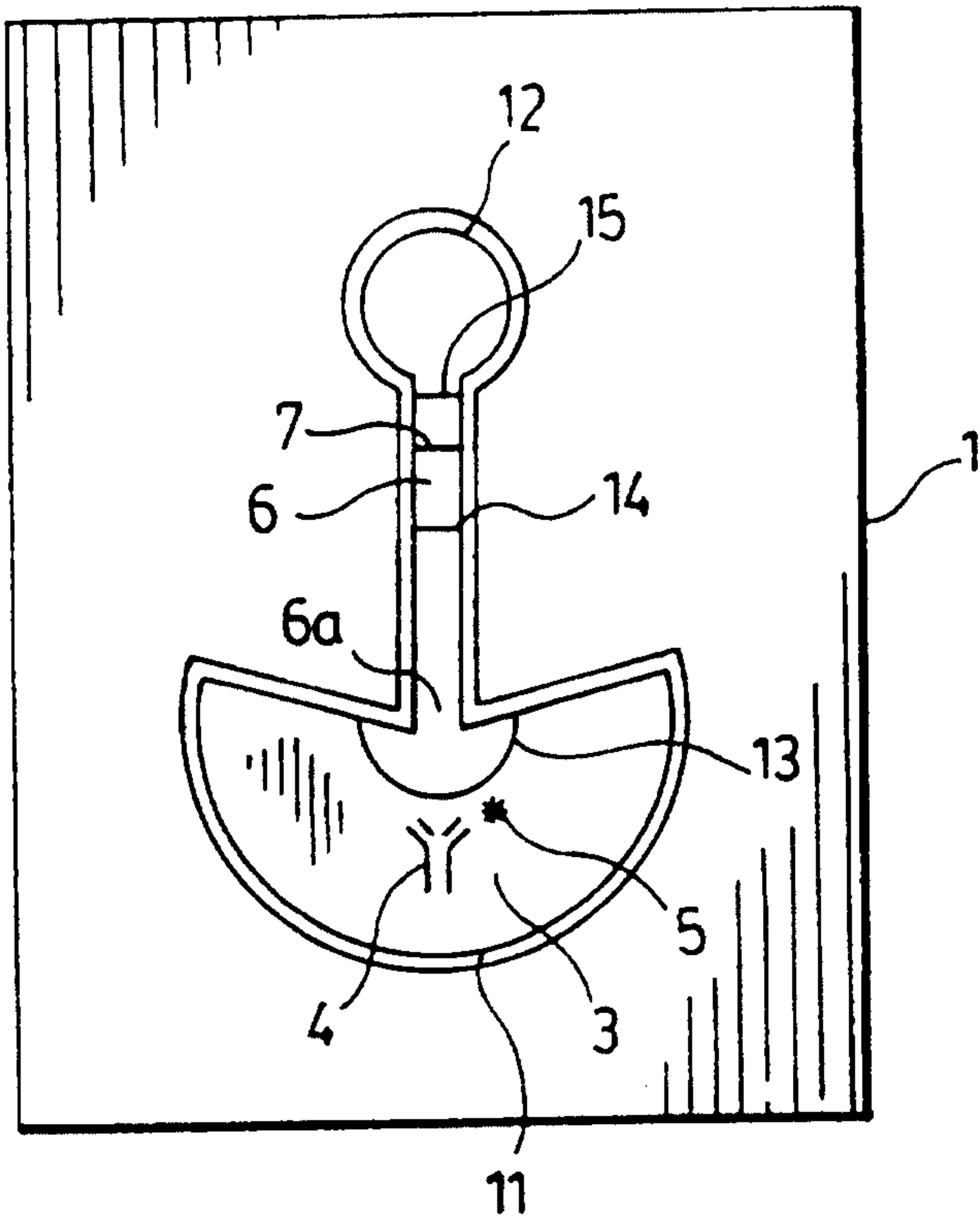
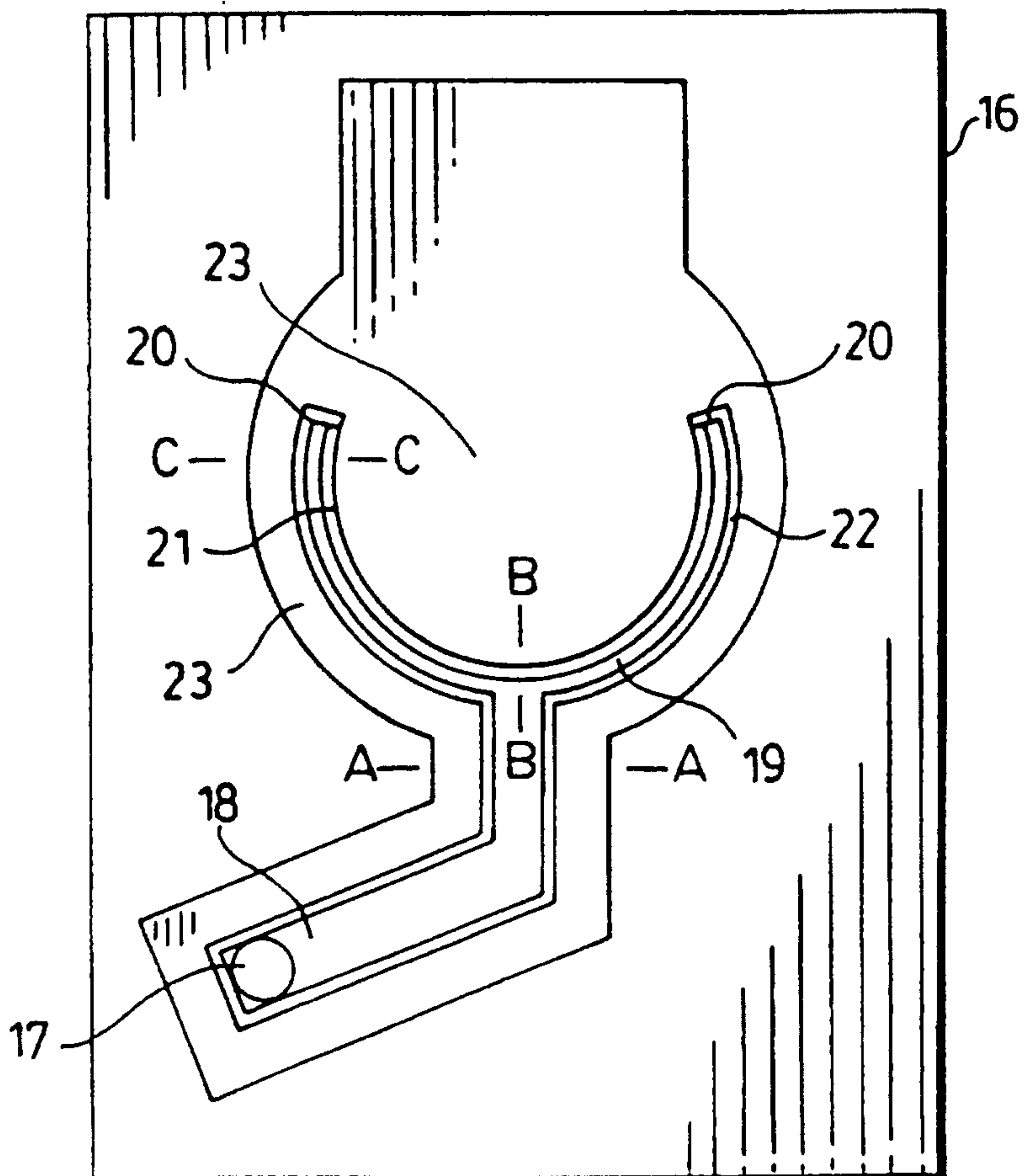
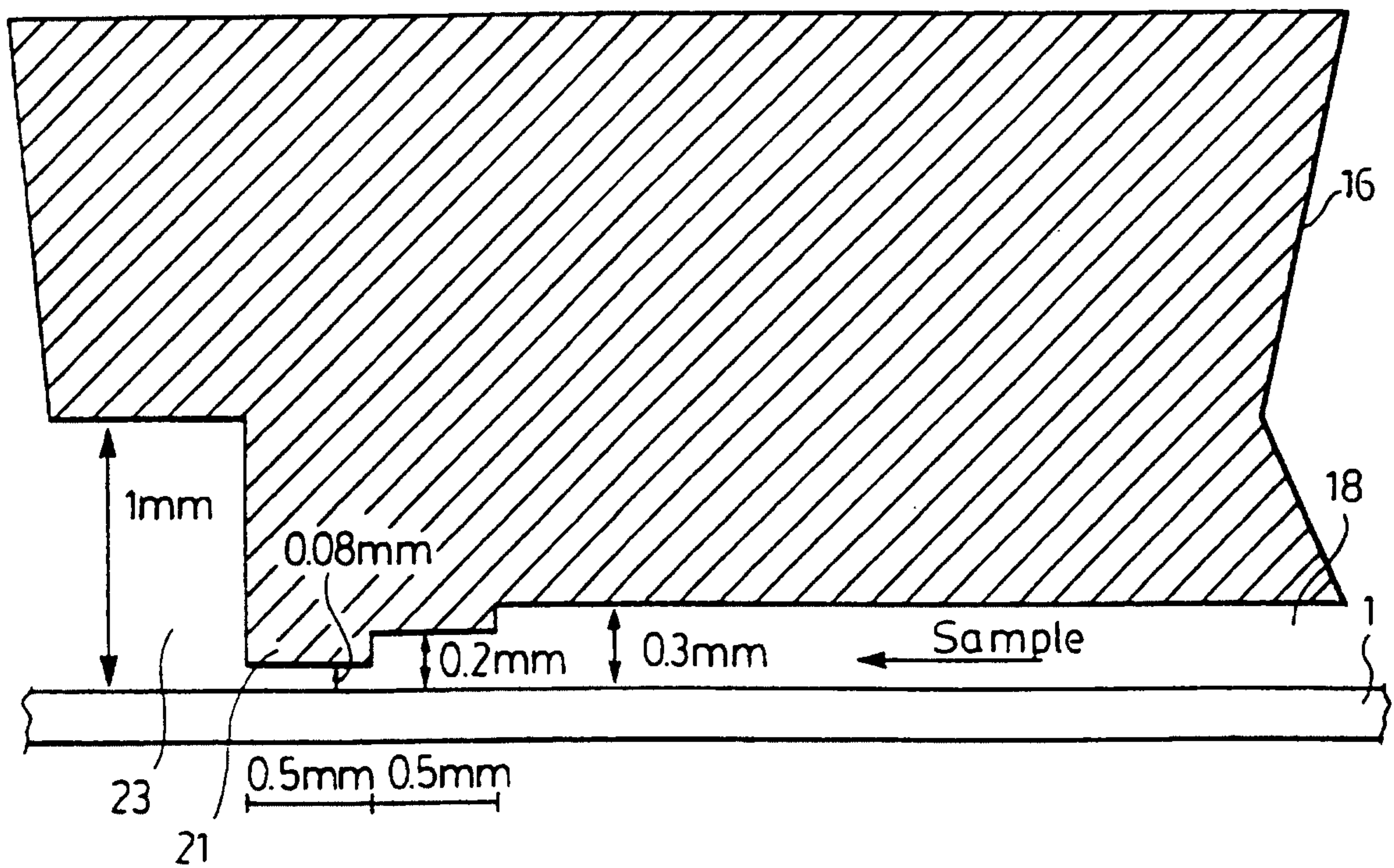
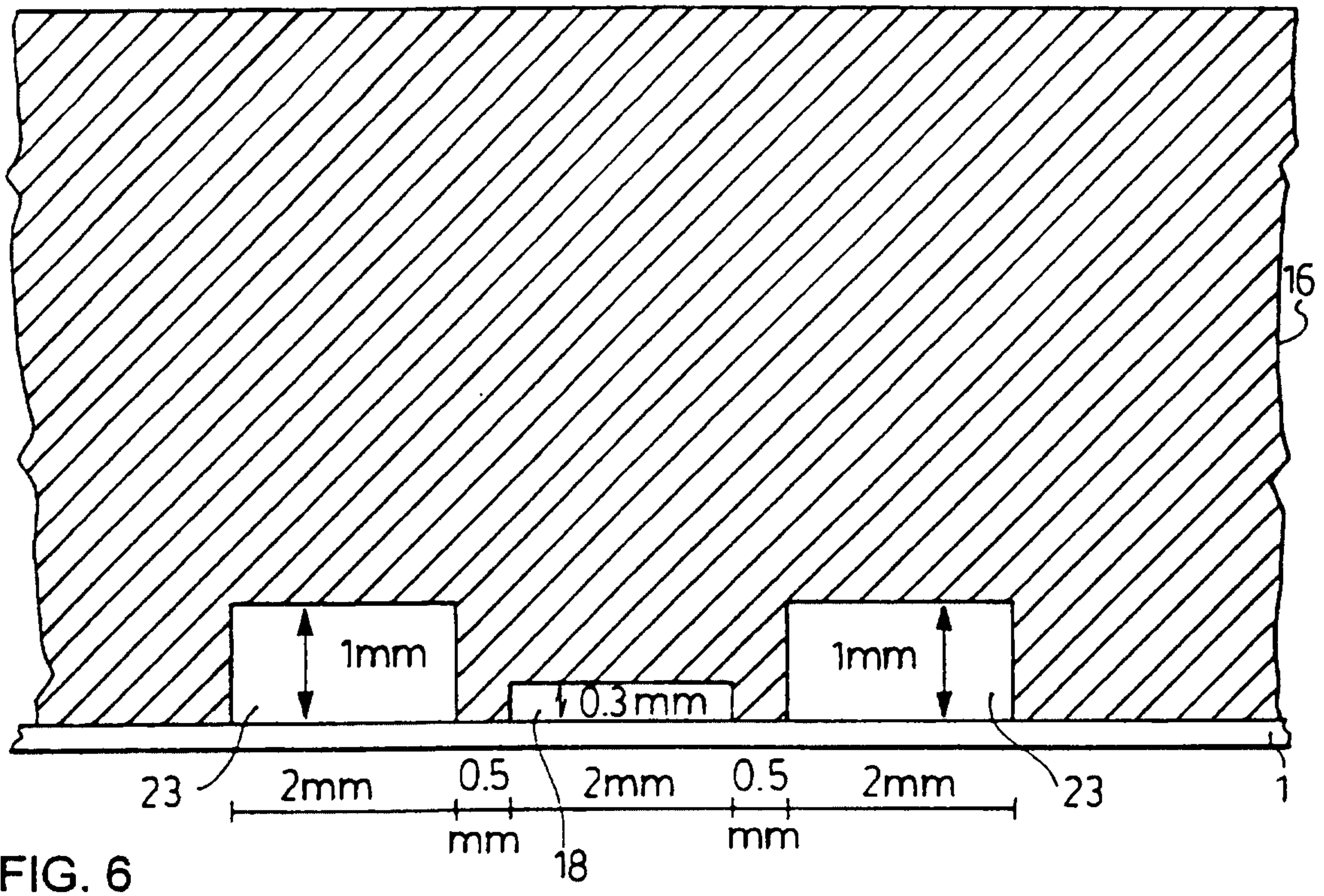

FIG. 4

FIG. 5





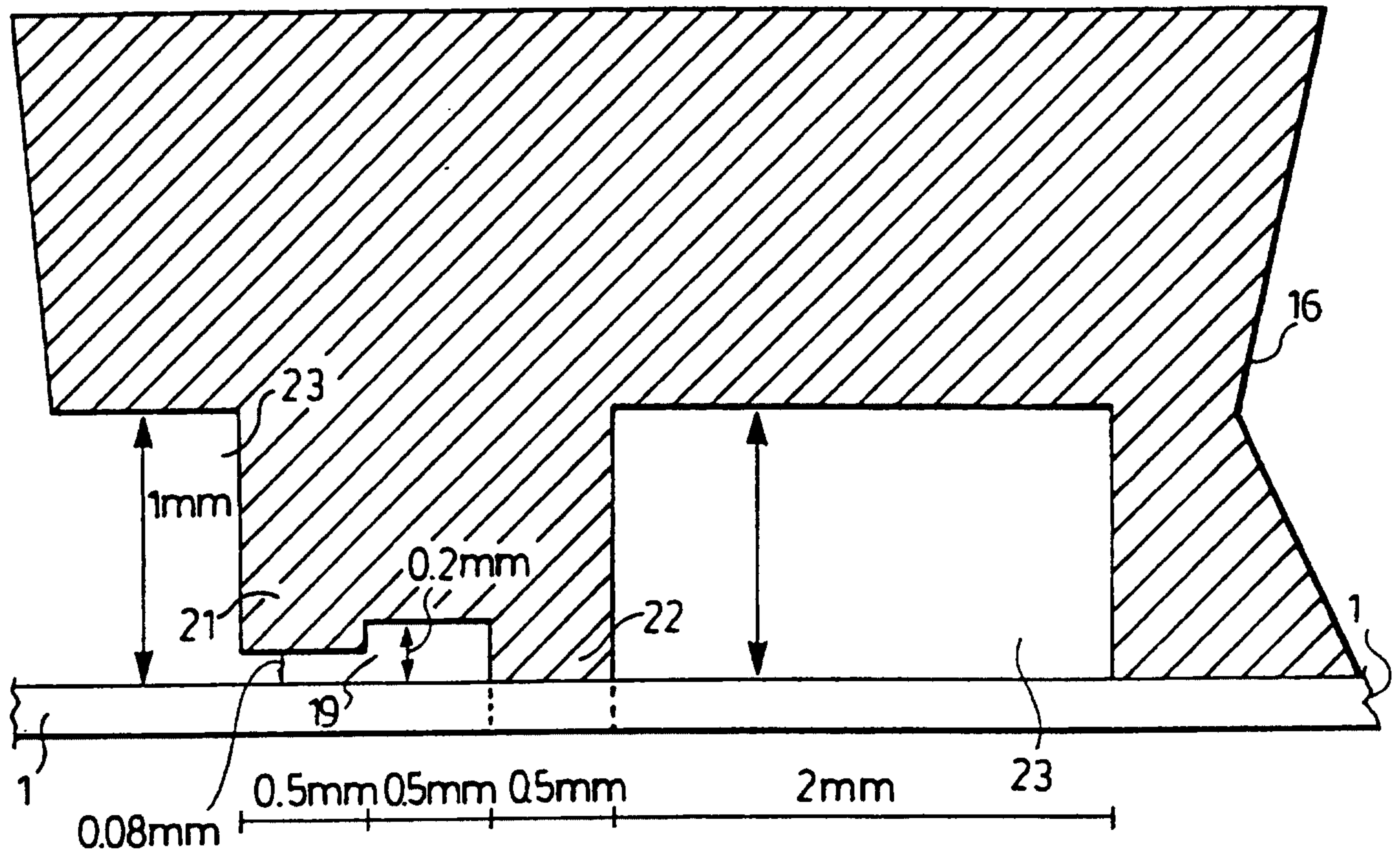
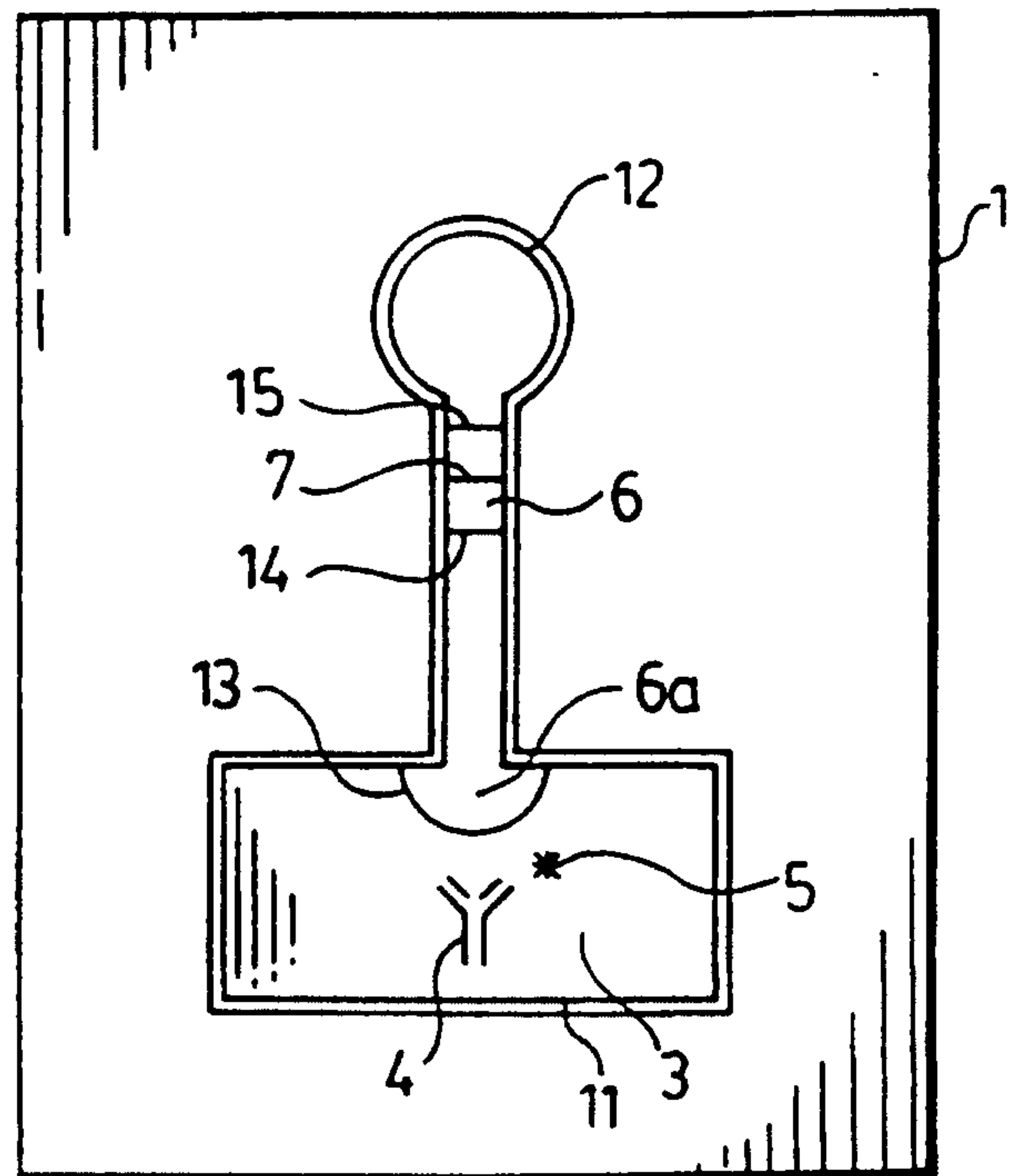

FIG. 8

FIG. 9



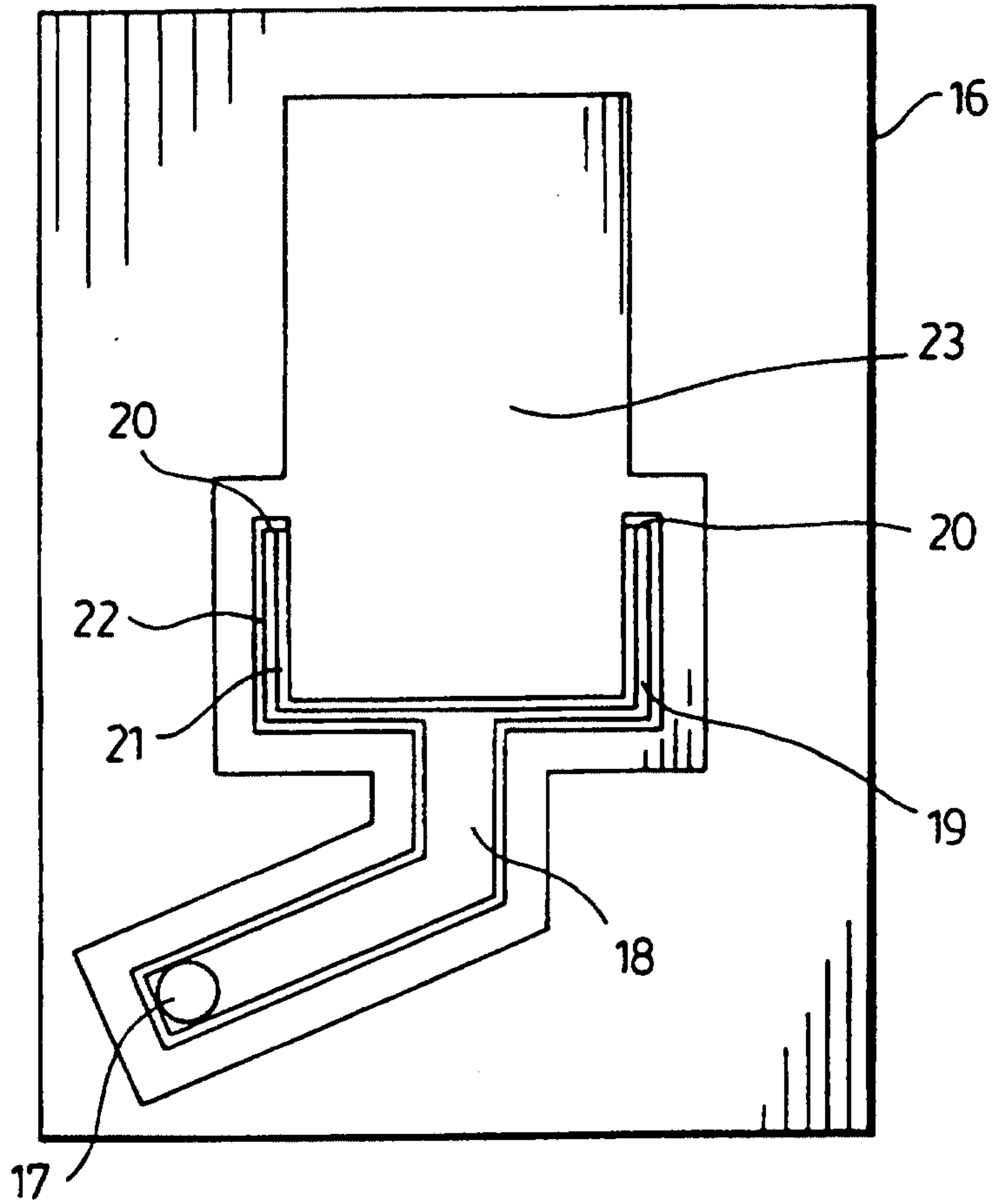

FIG. 10

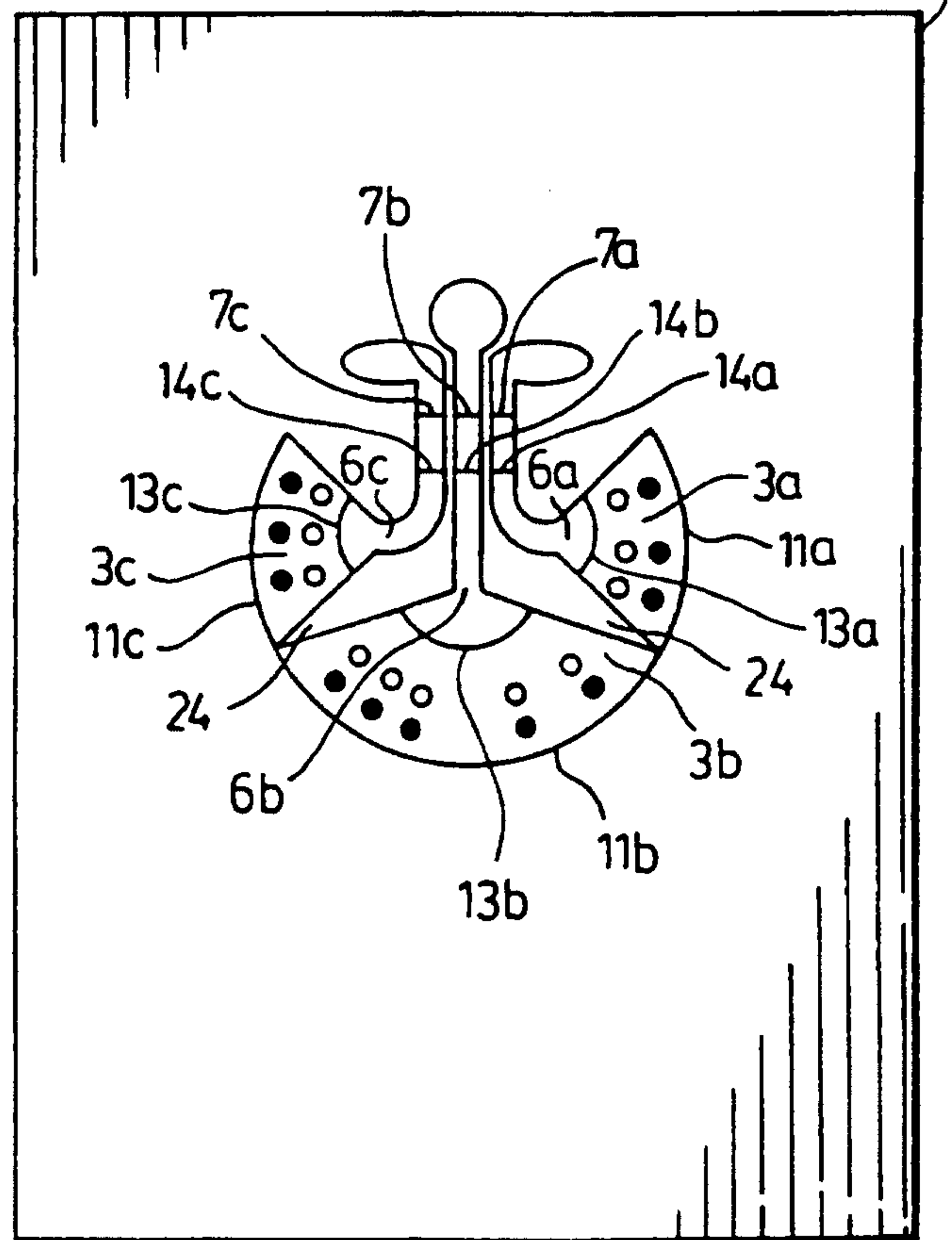

FIG. 11

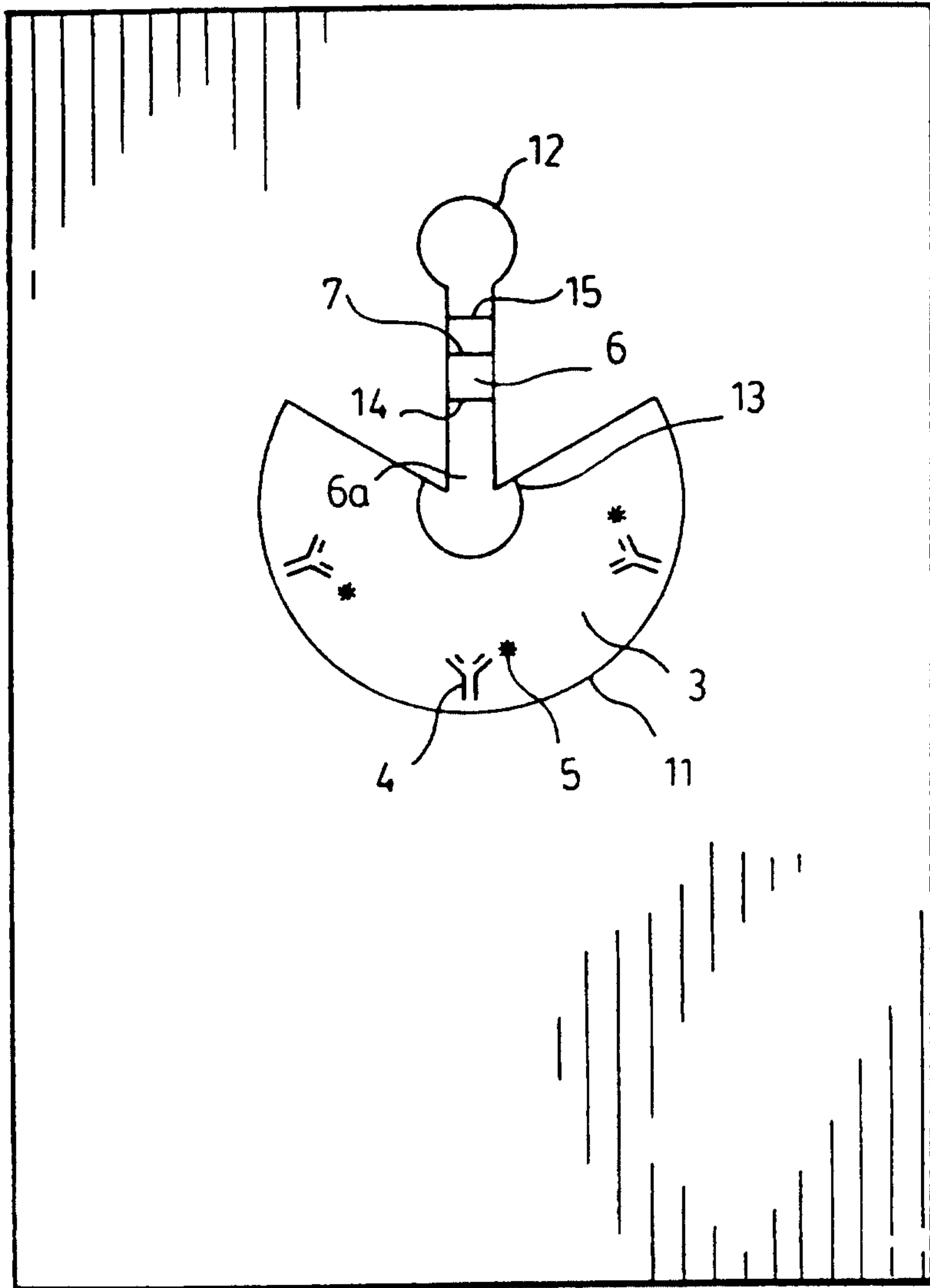

FIG. 12

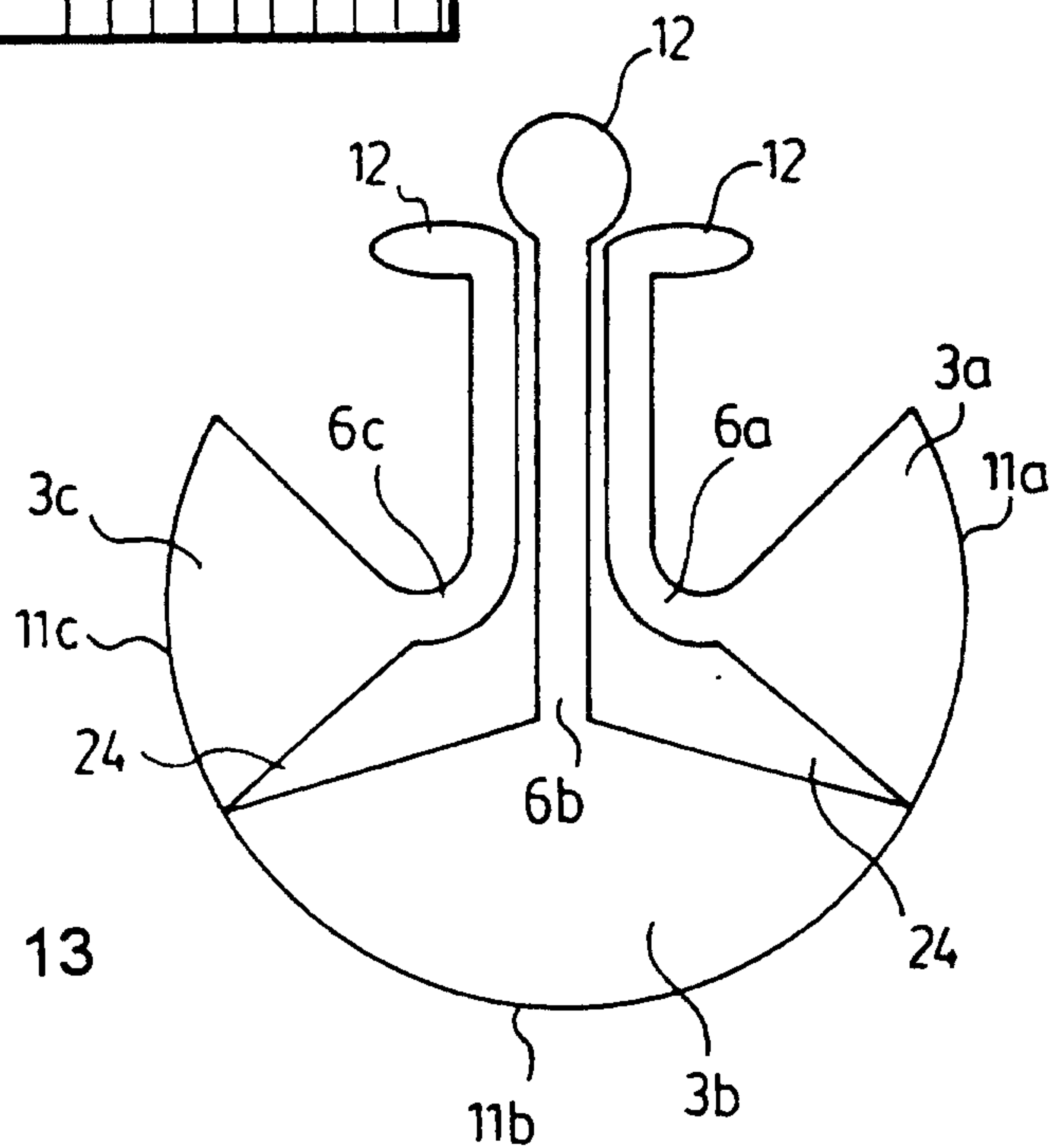

FIG. 13

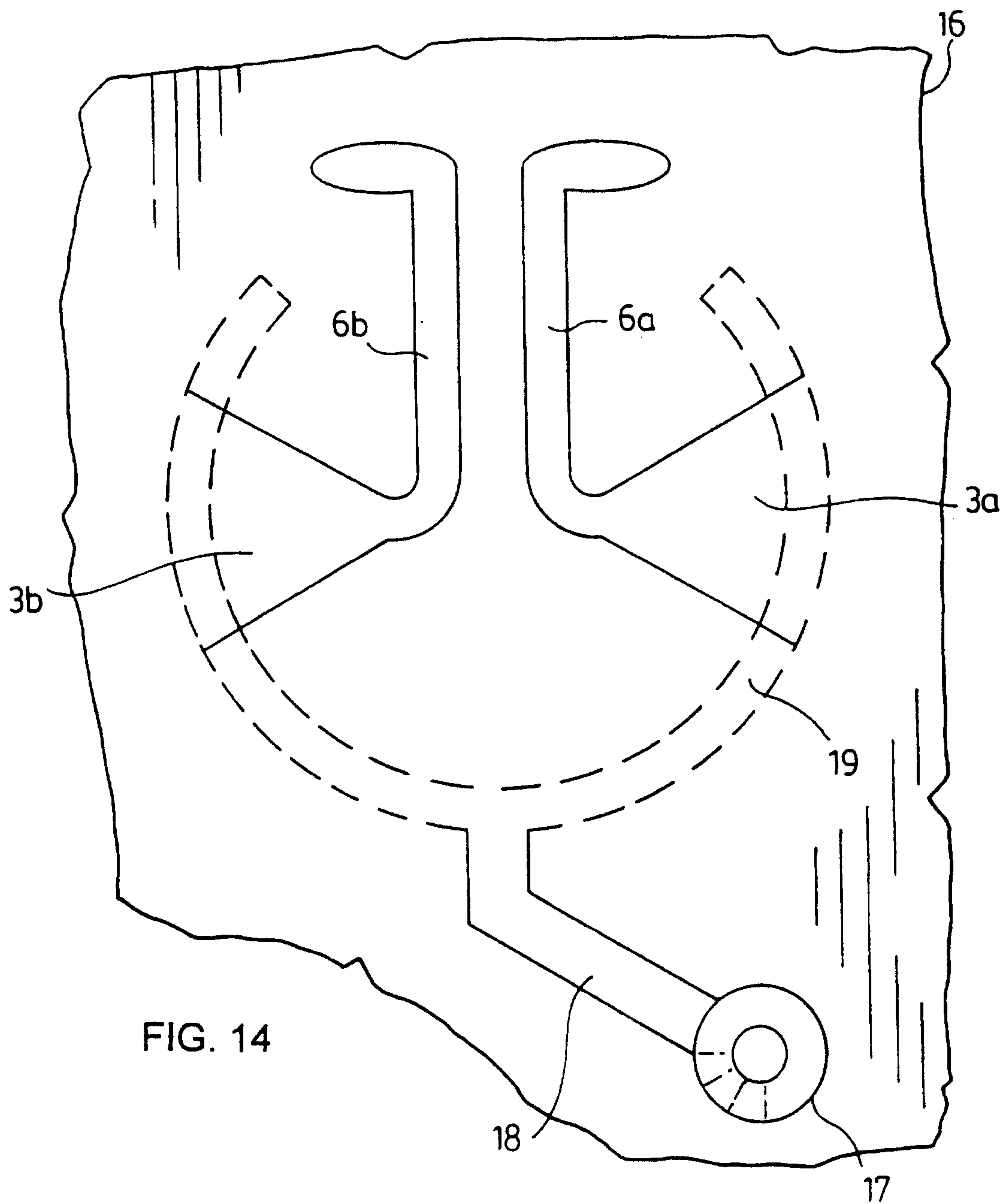

FIG. 14

FIG. 15

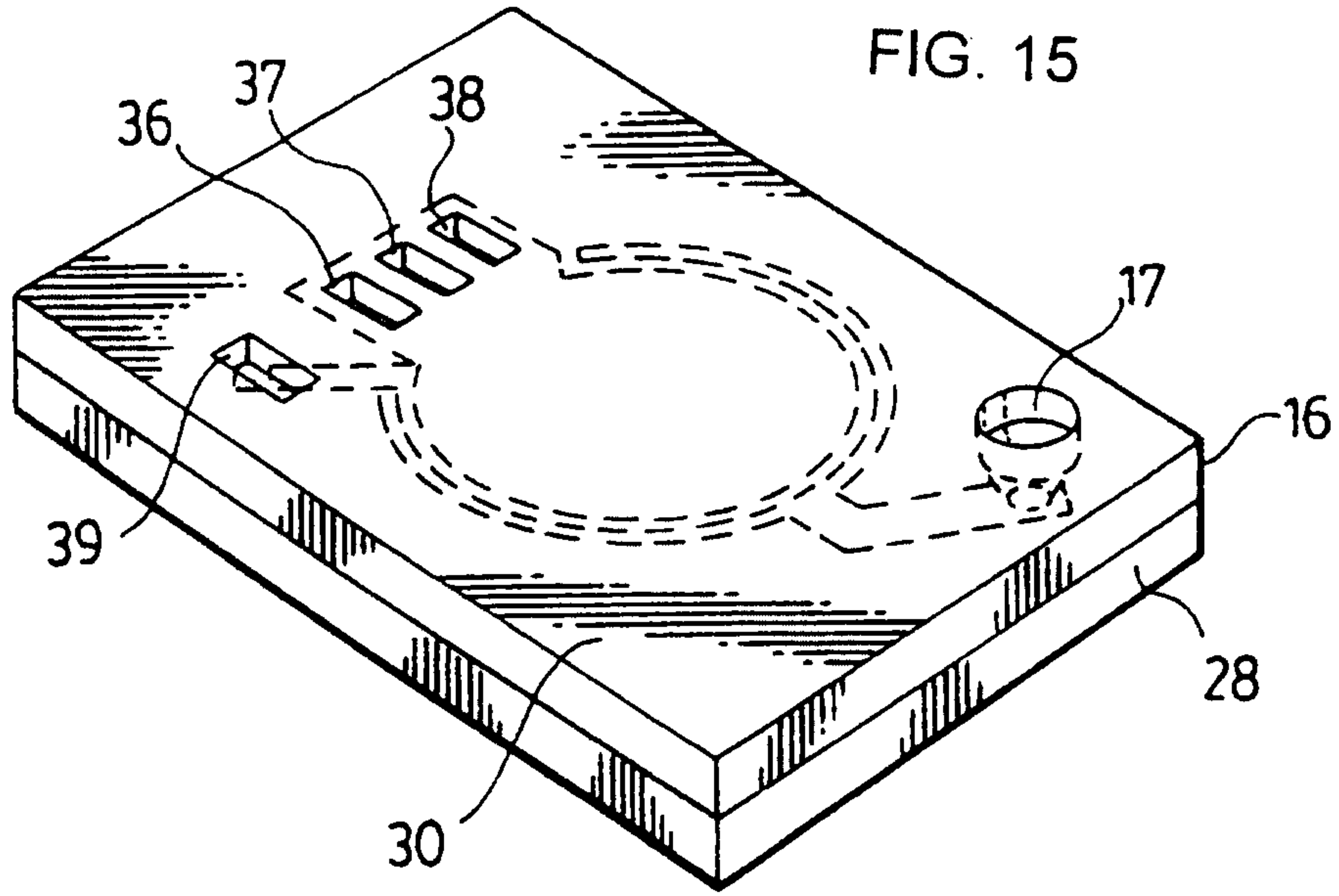

FIG. 16A

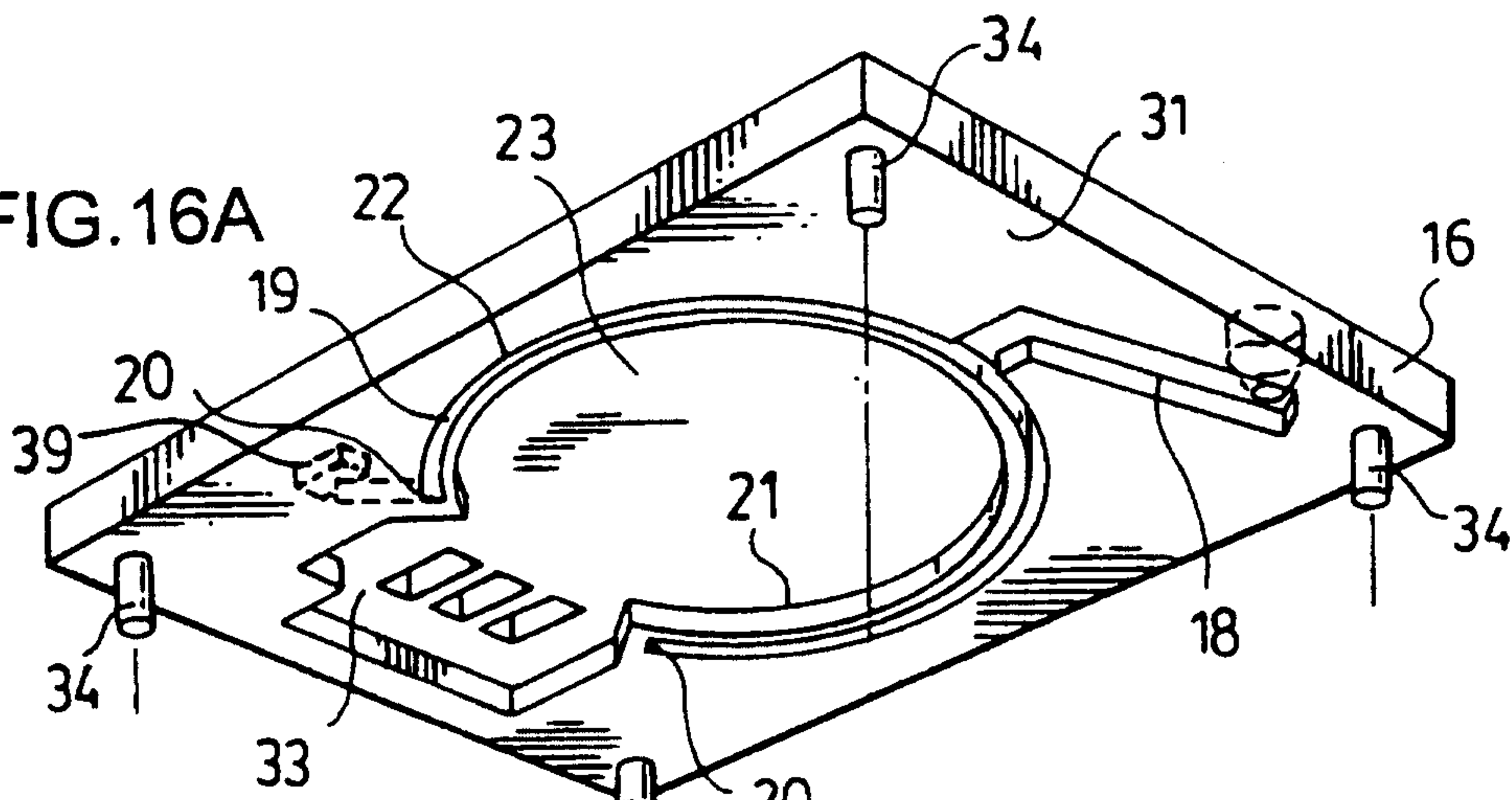

FIG. 16B

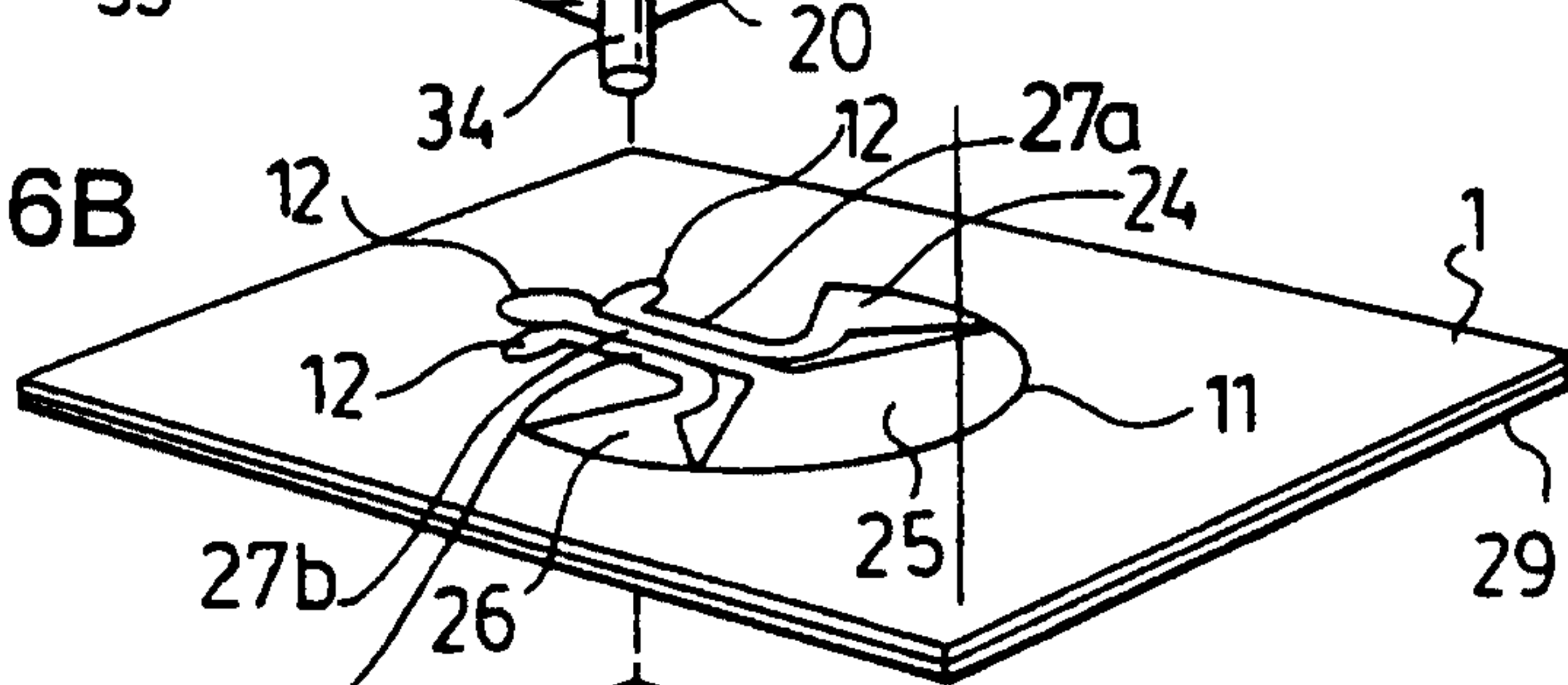

FIG. 16C

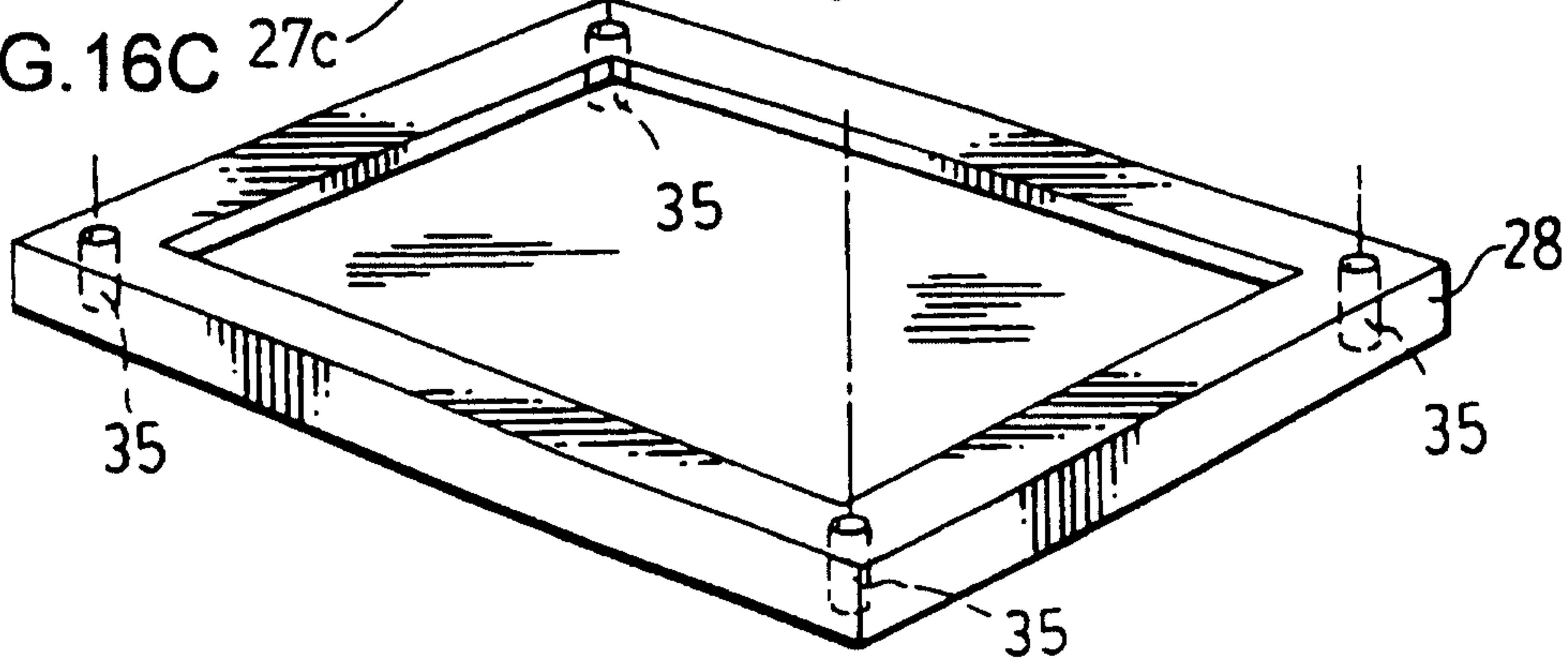
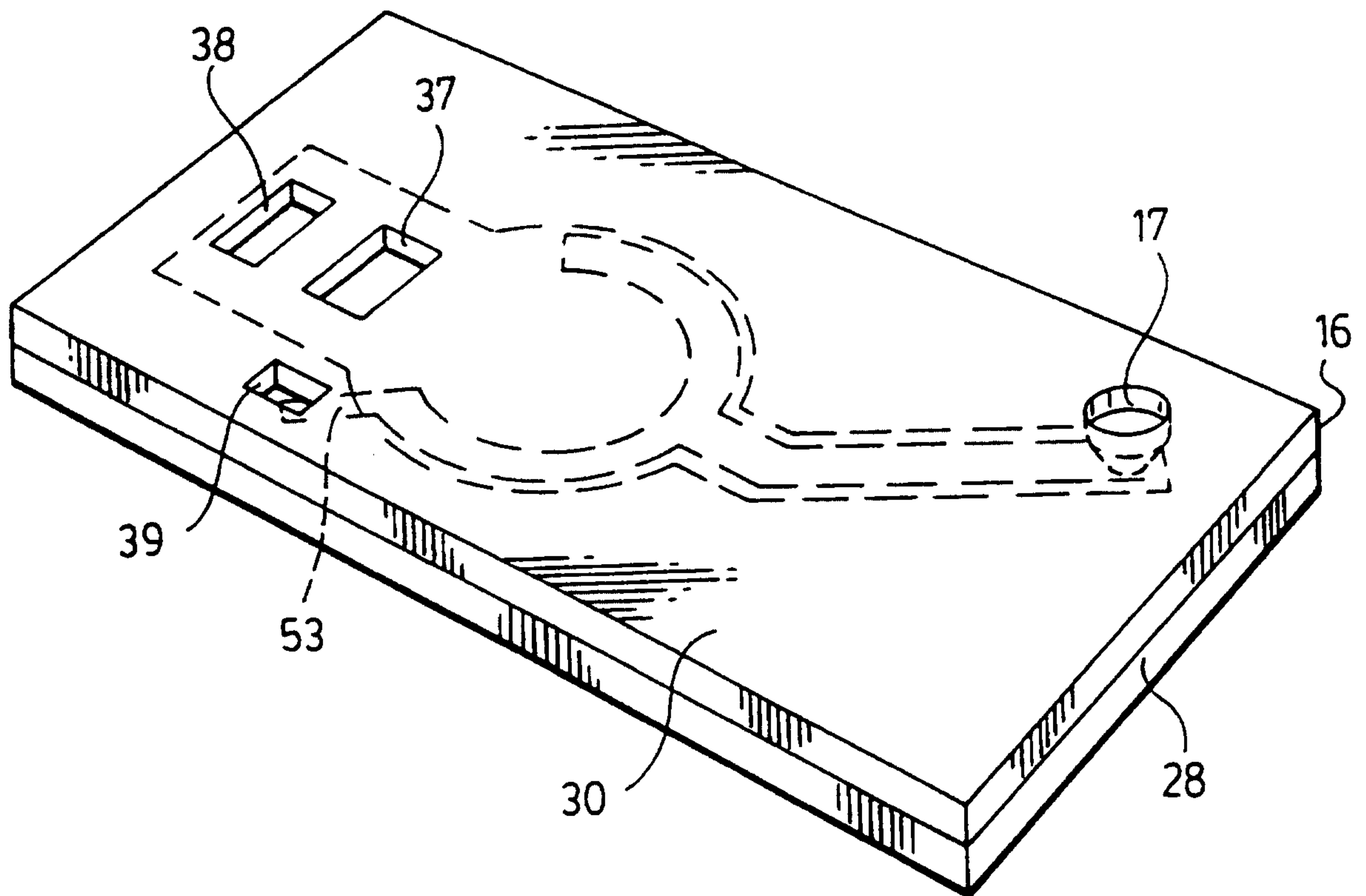
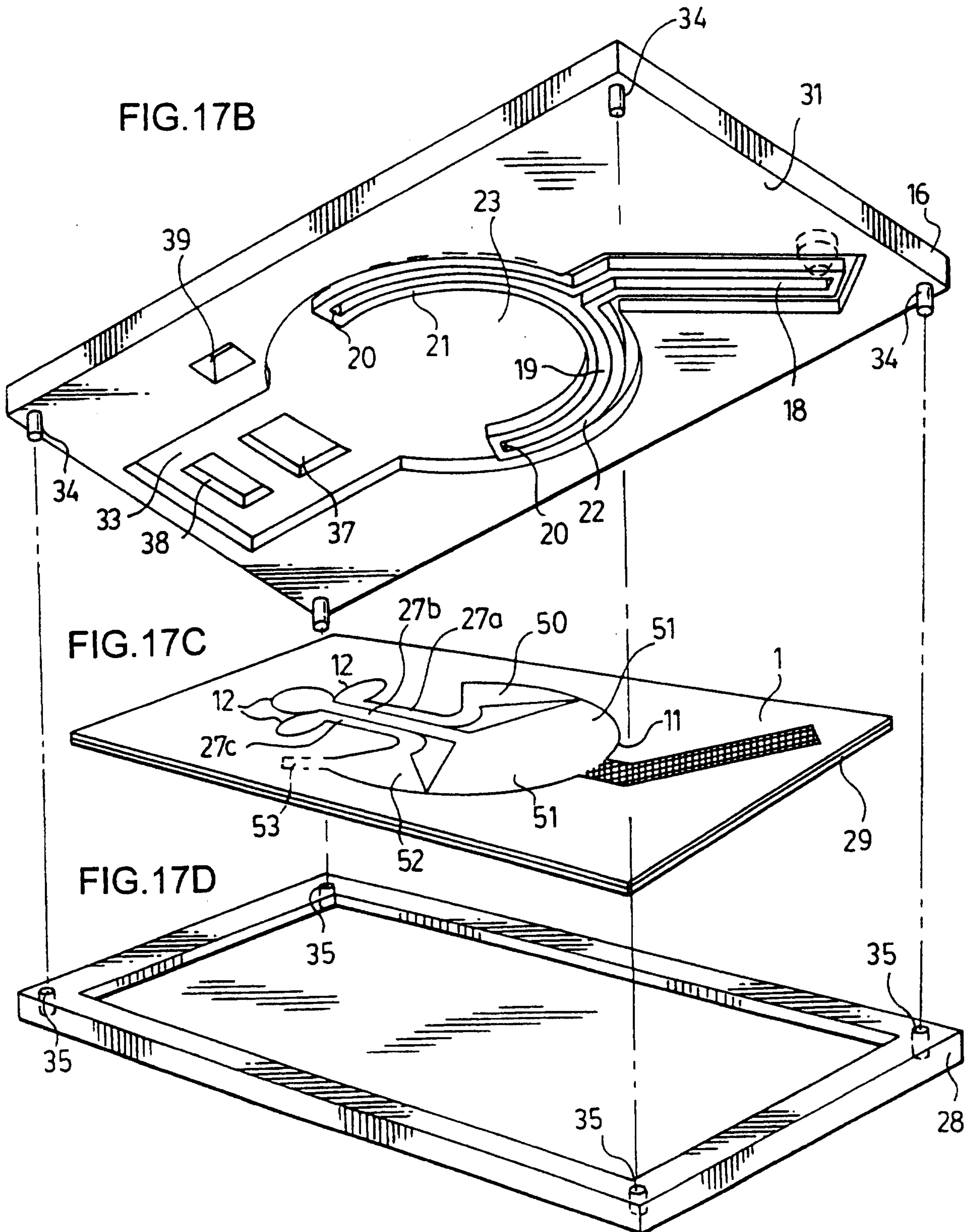

FIG.17A





11/25

FIG. 18

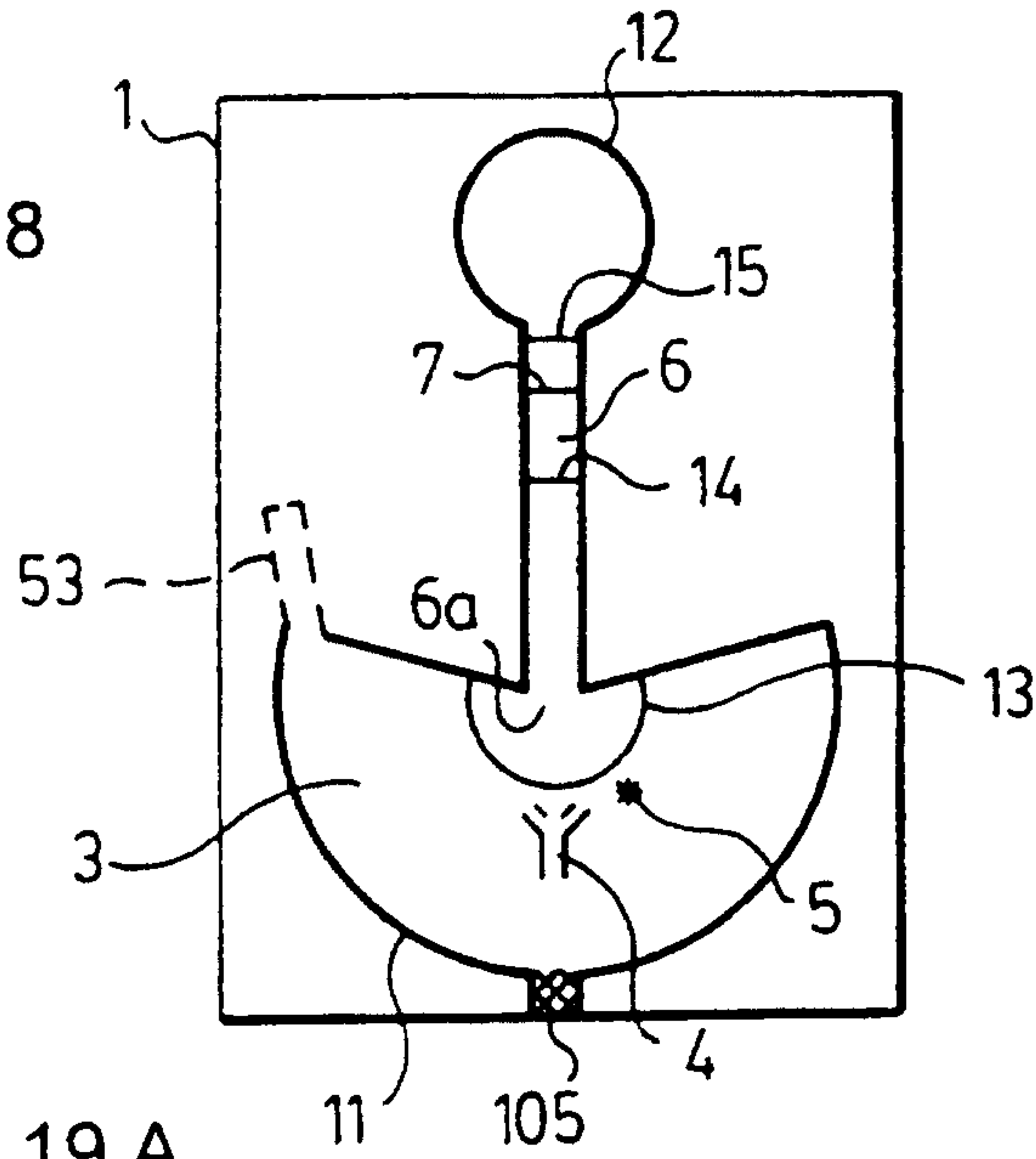

FIG. 19 A

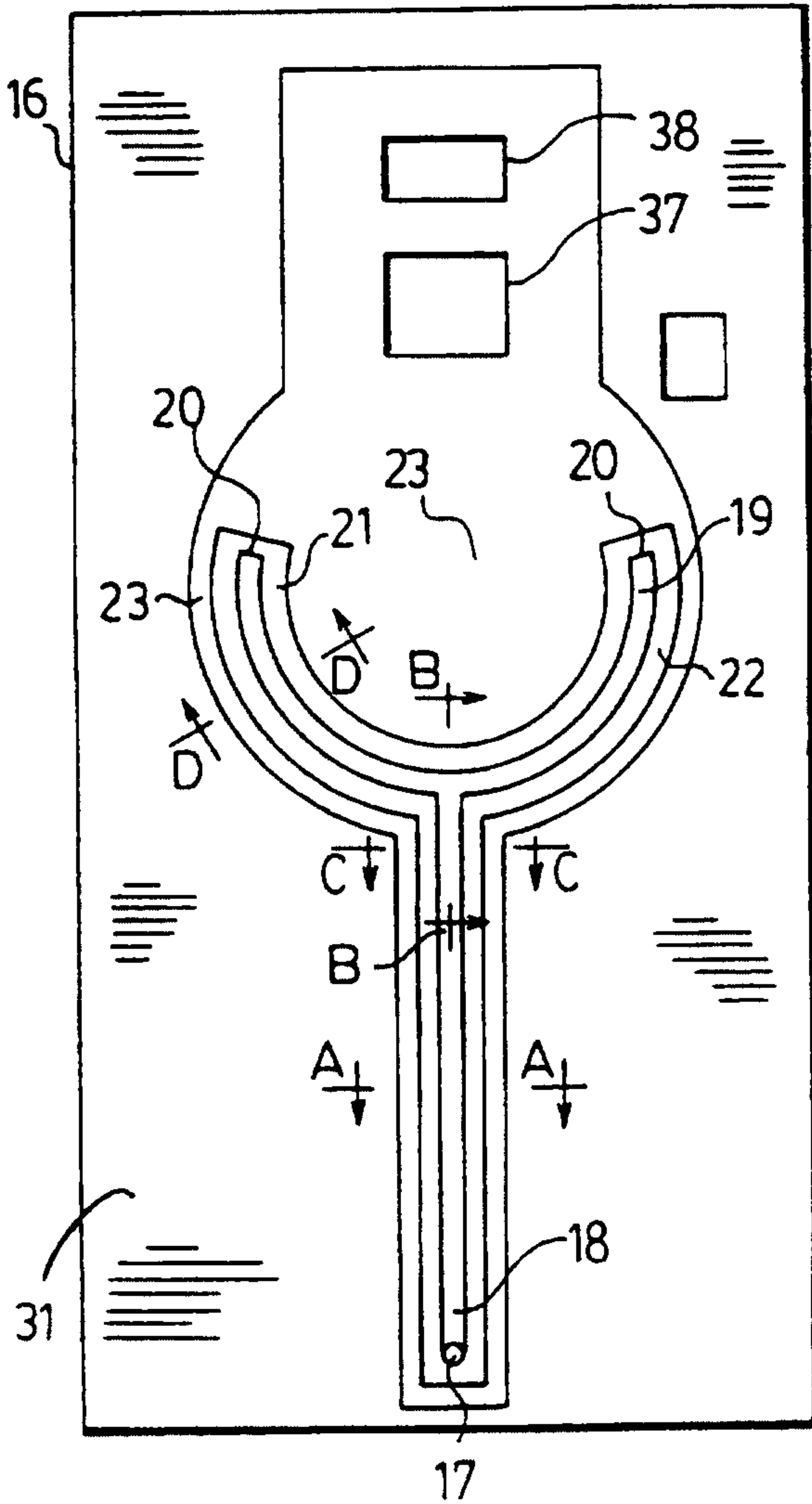
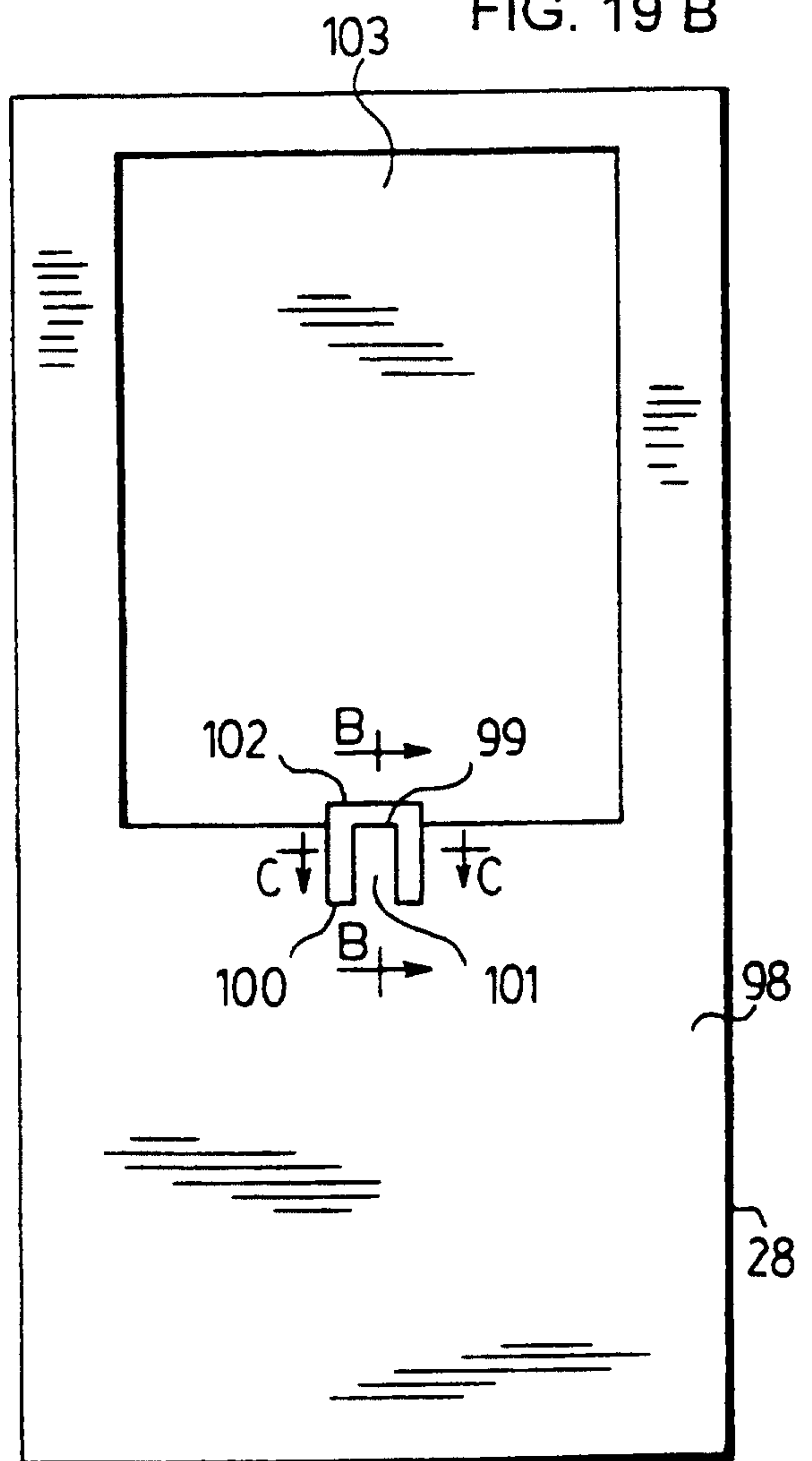

FIG. 19 B



12/25

FIG. 20 A-A

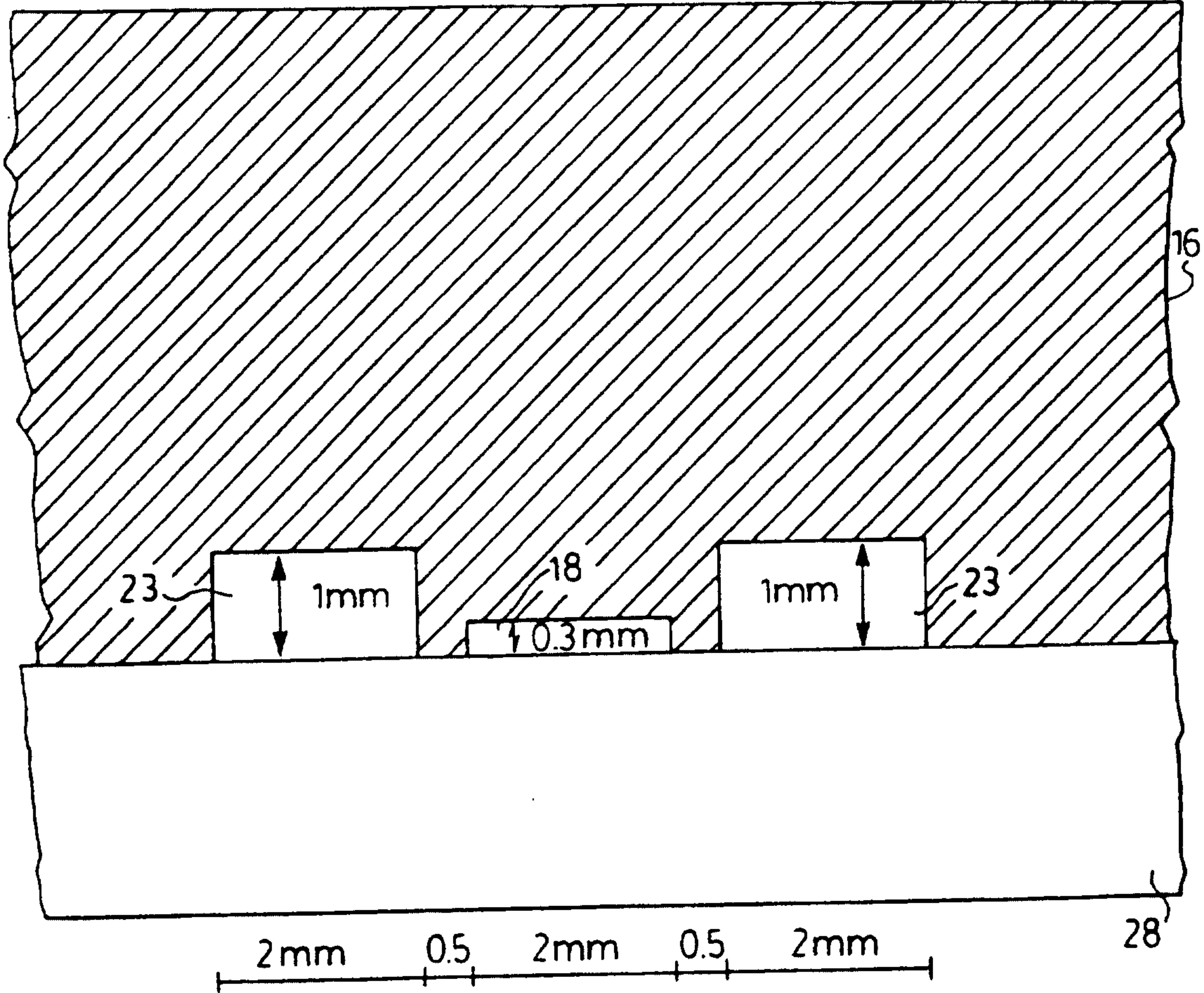
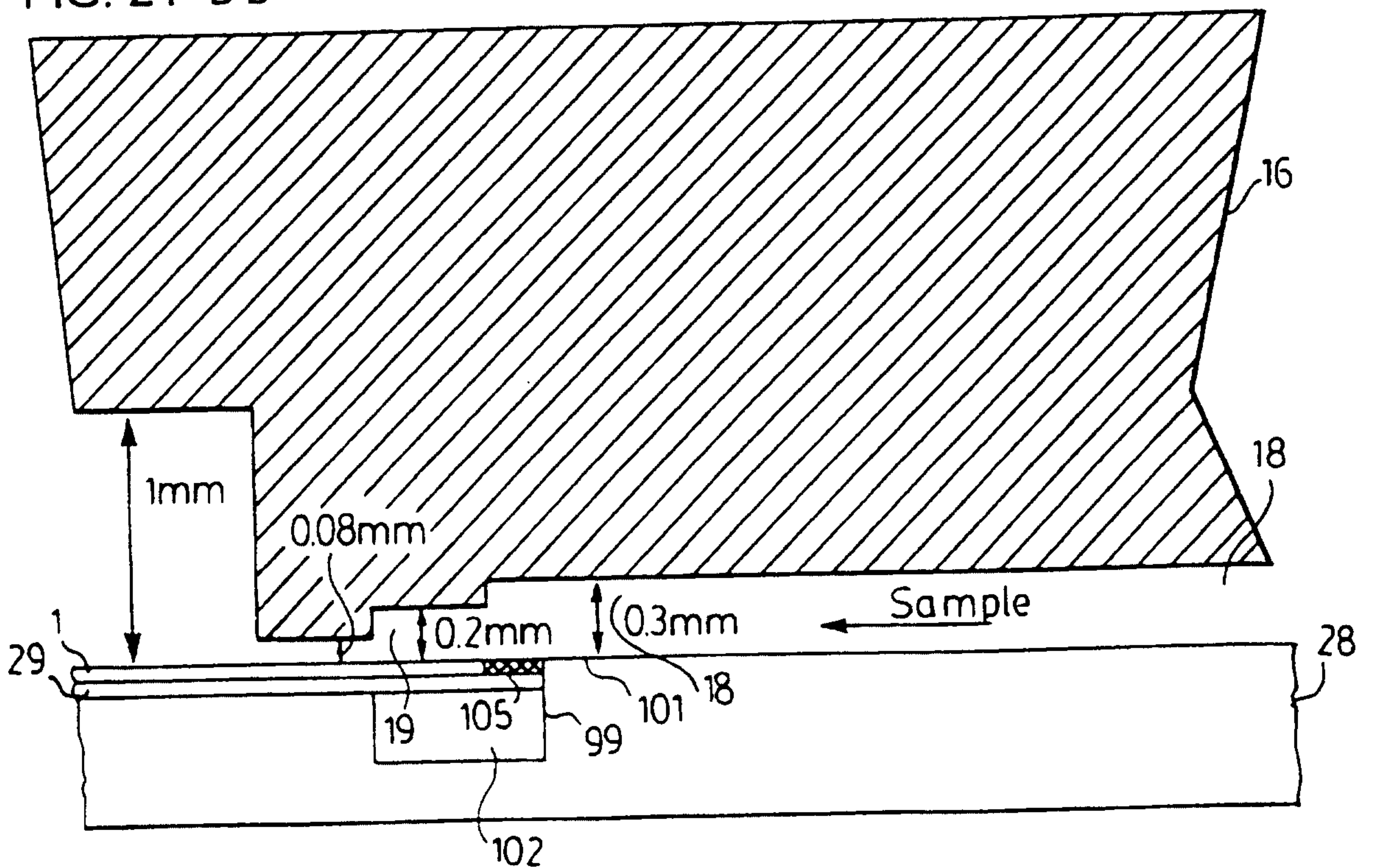

FIG. 21 B-B



13/25

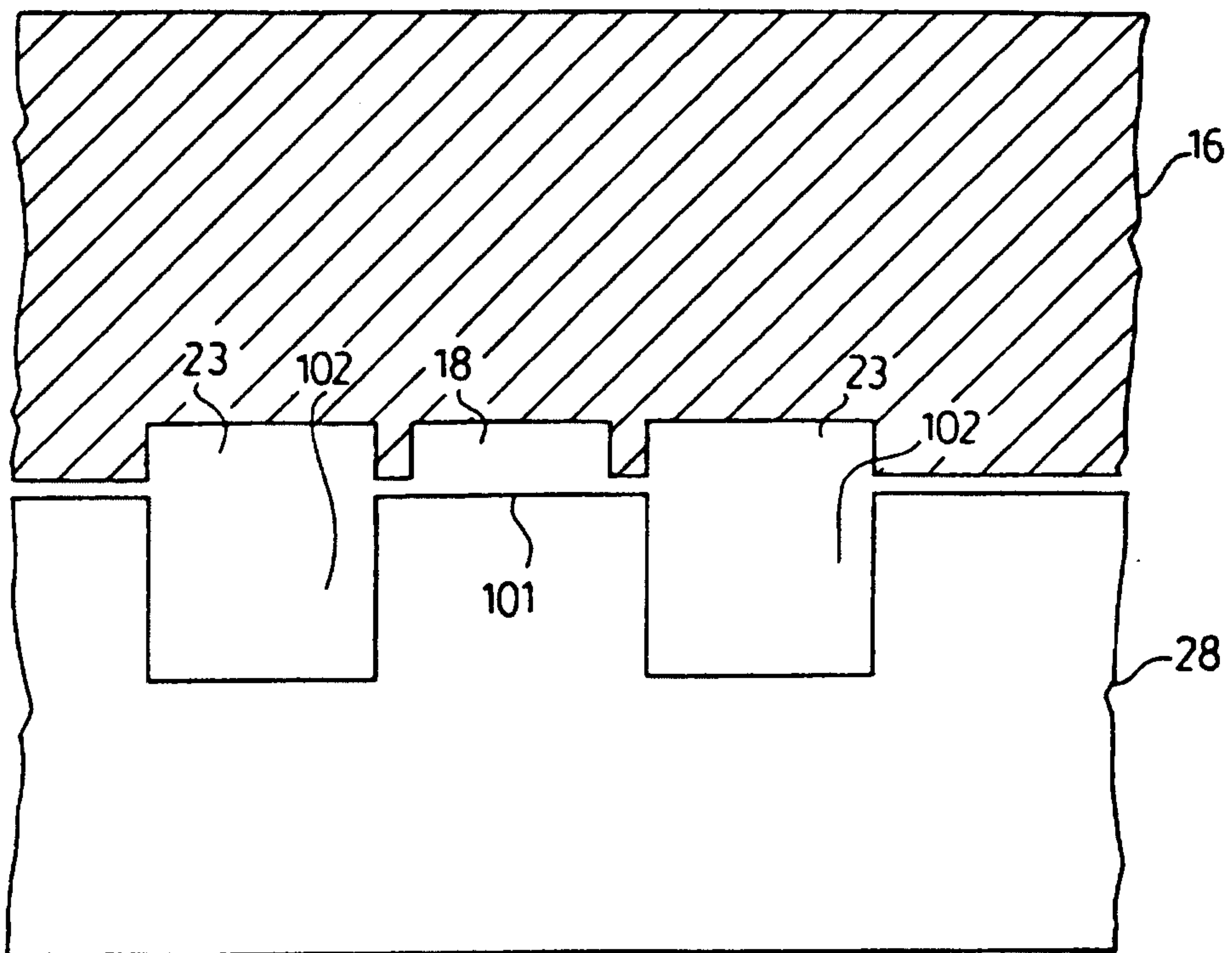
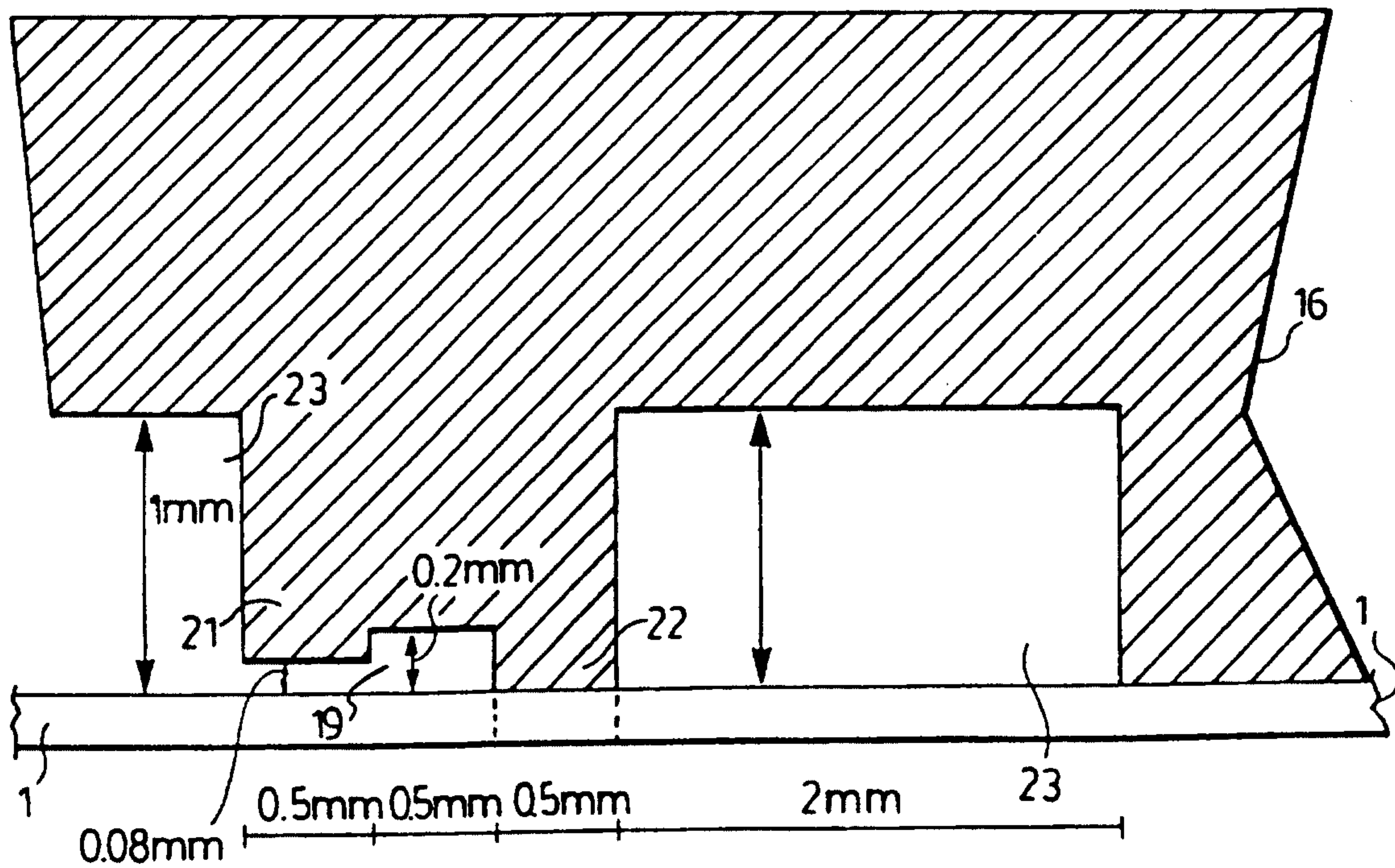

FIG. 22 c-c

FIG. 23 D-D



15/25

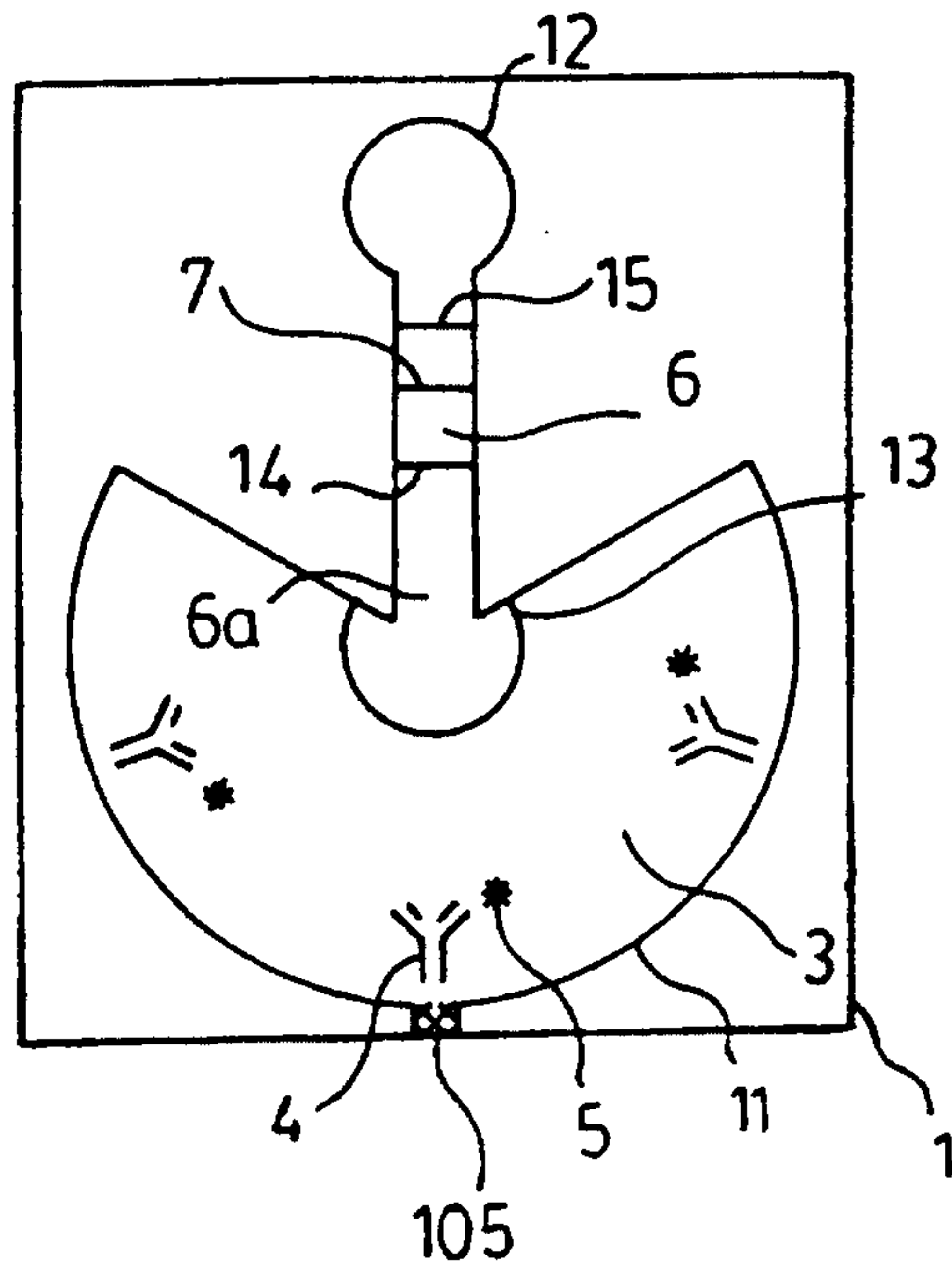

FIG. 26

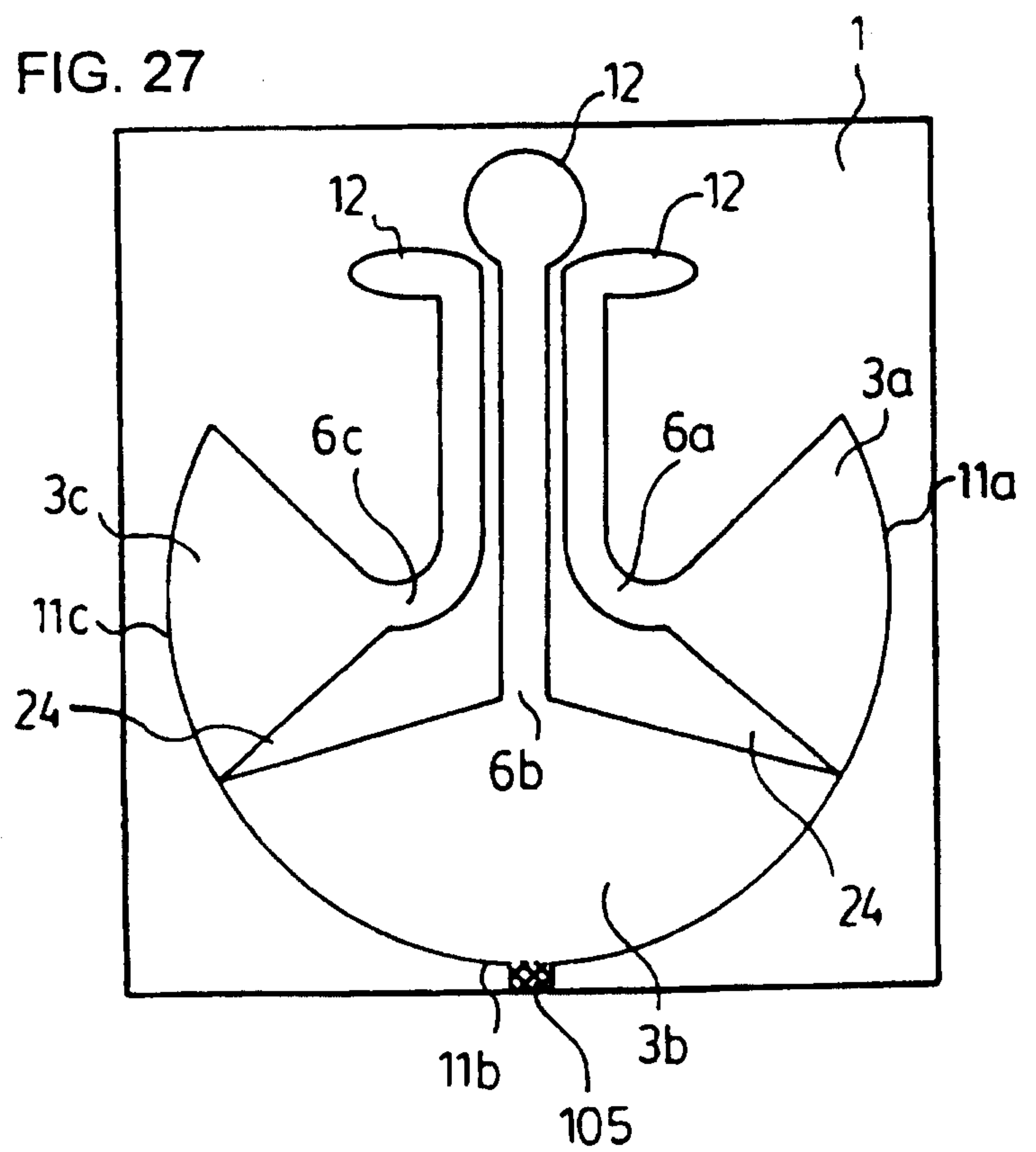

FIG. 27

16/25

FIG. 28 A

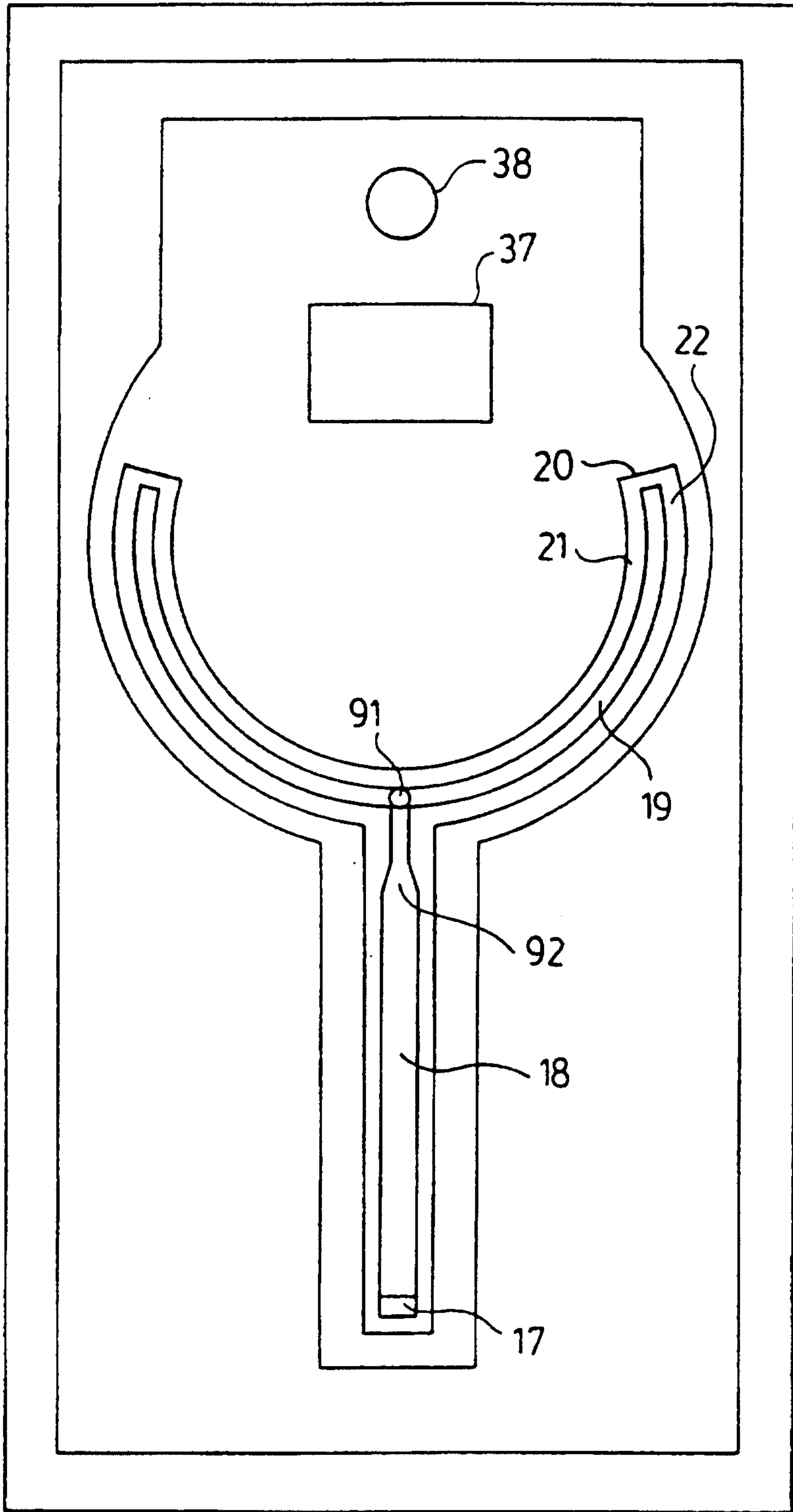
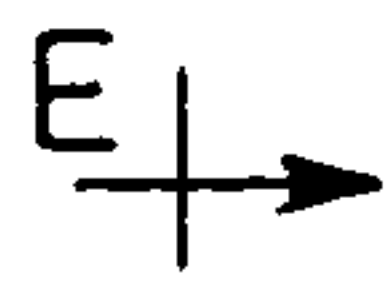
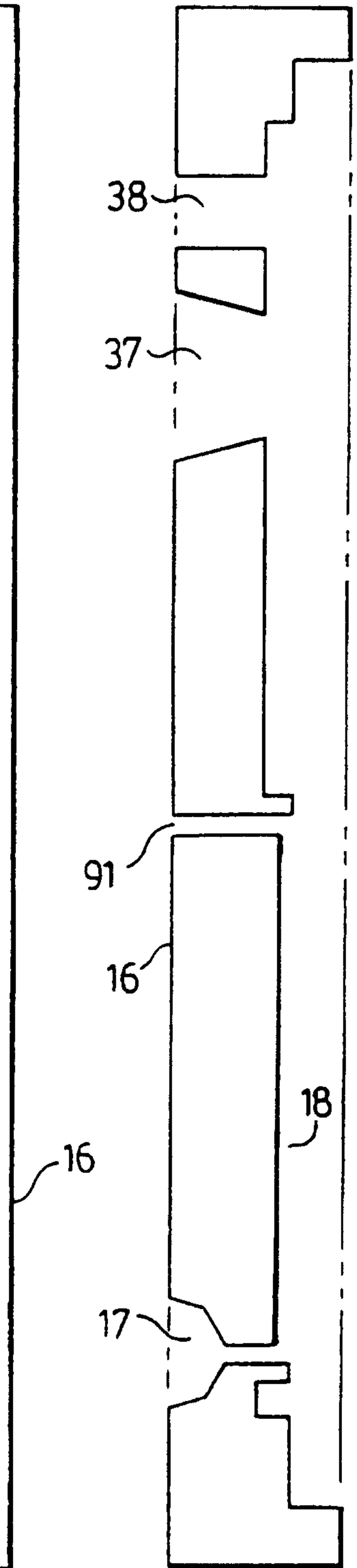

FIG. 28 B

E-E



17/25

FIG. 29

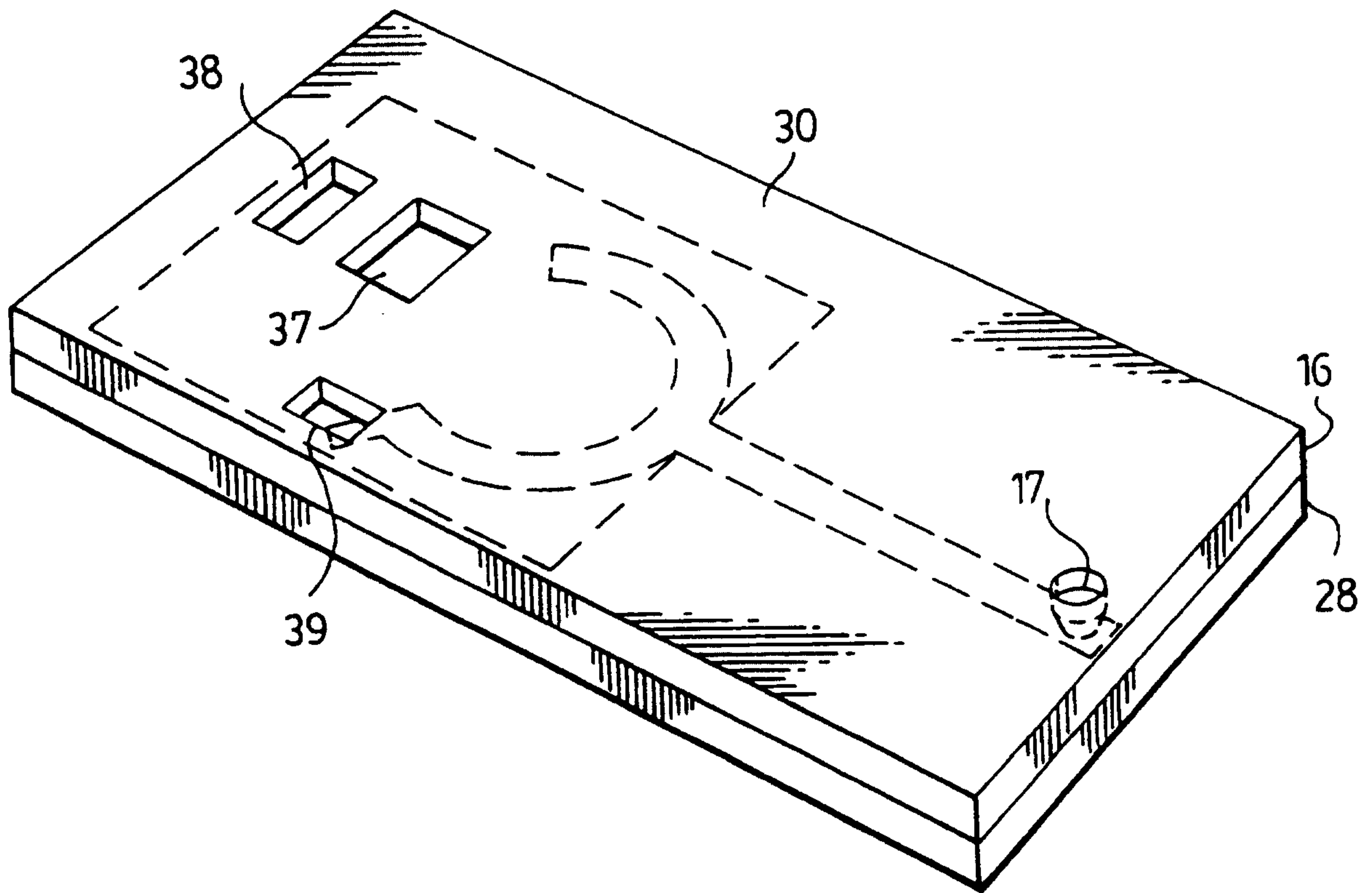

18/25

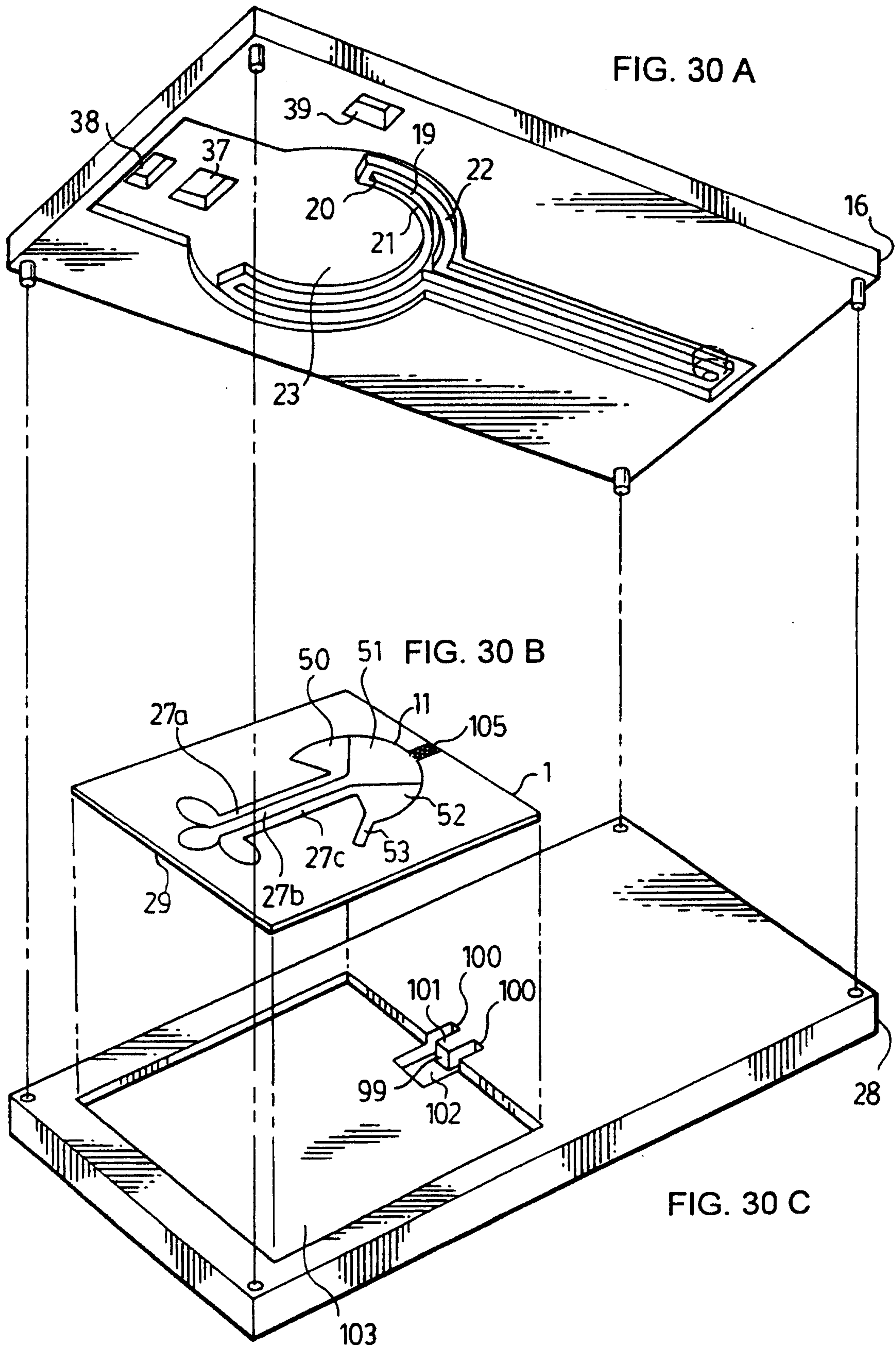

FIG. 31

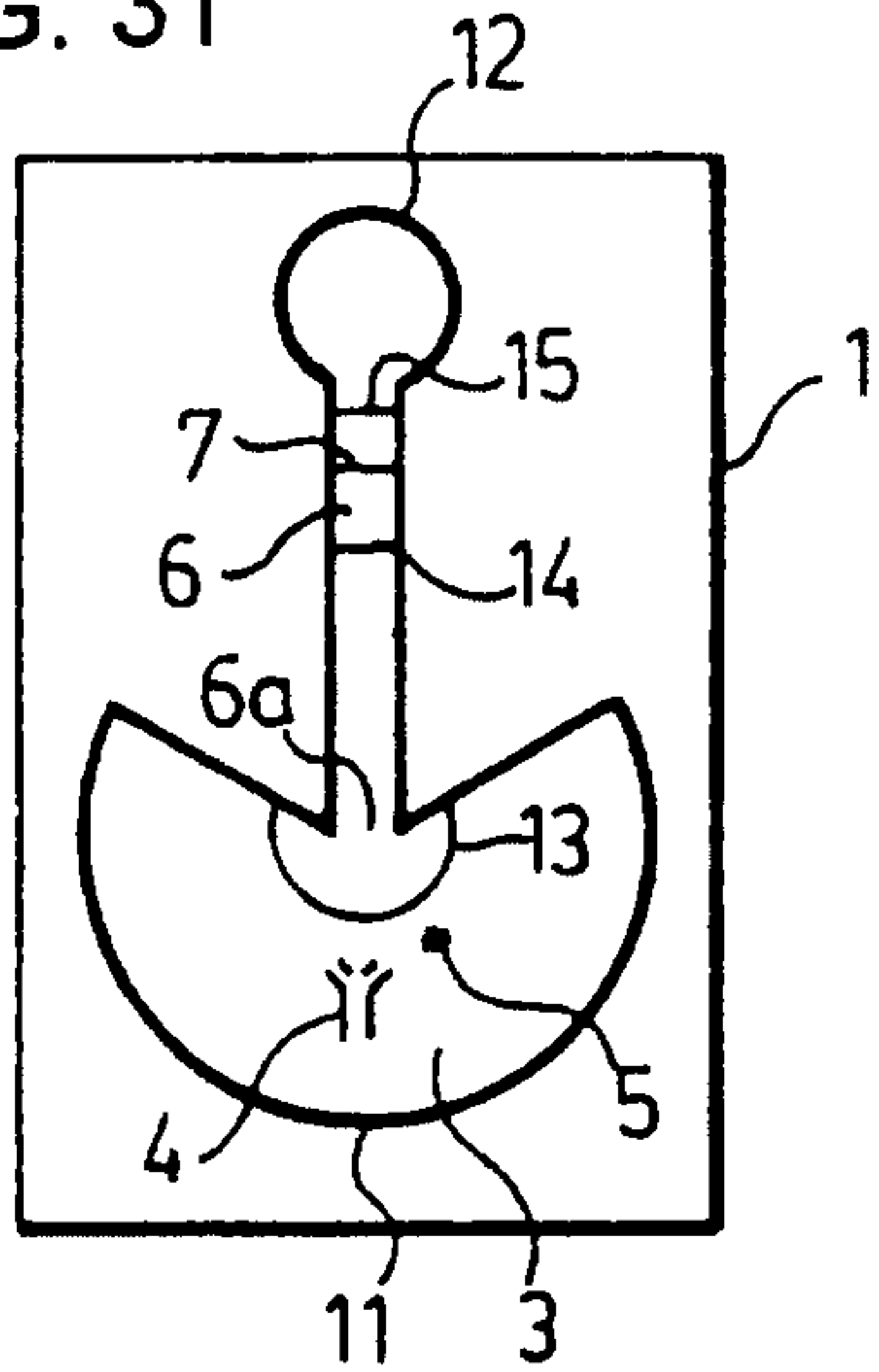

FIG. 32 A

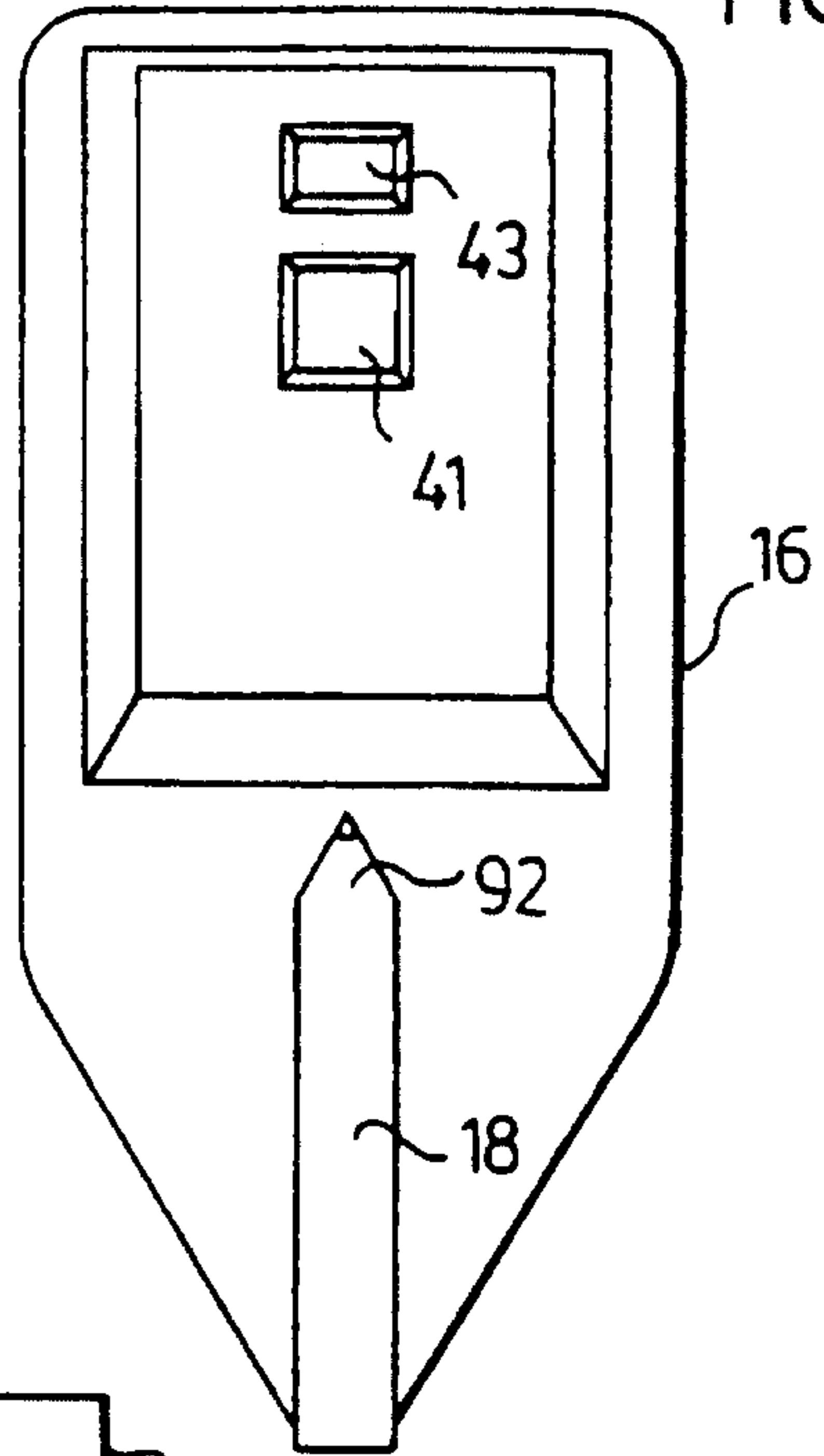

FIG. 32 B

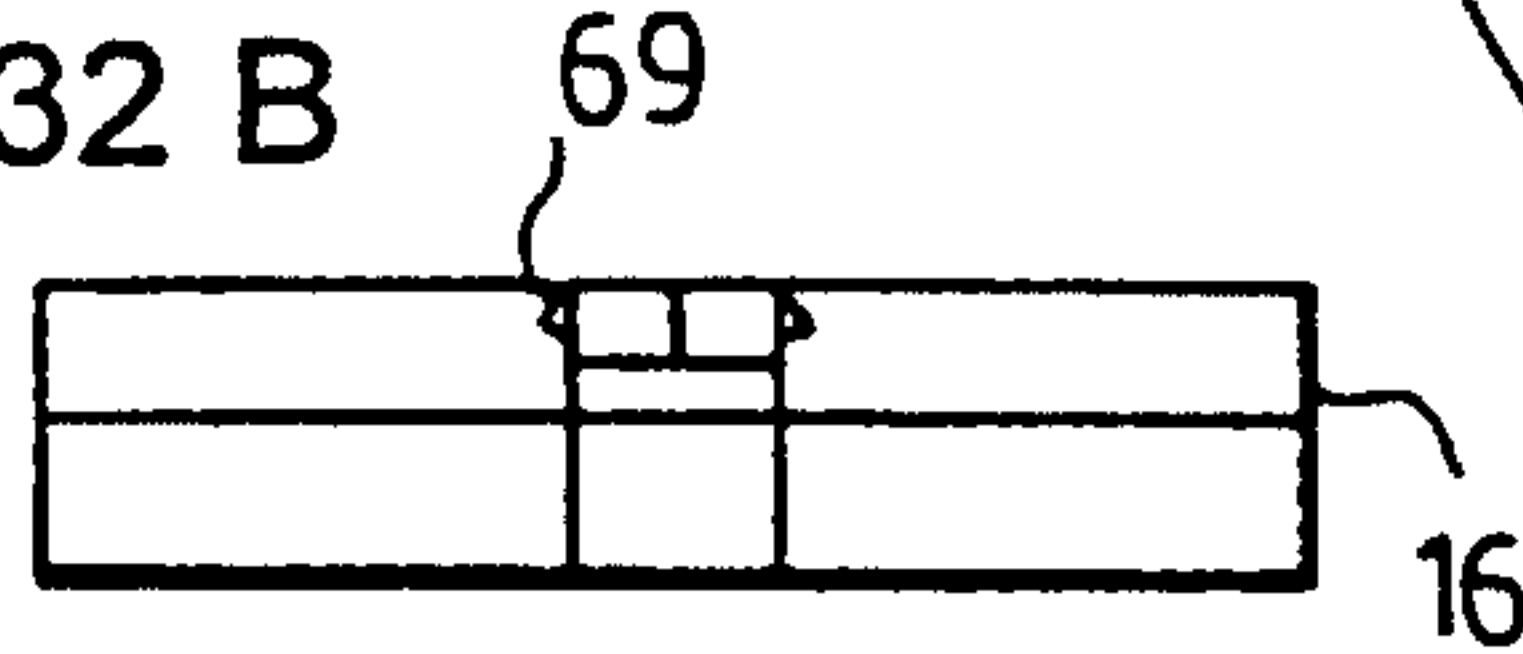

FIG. 32 C

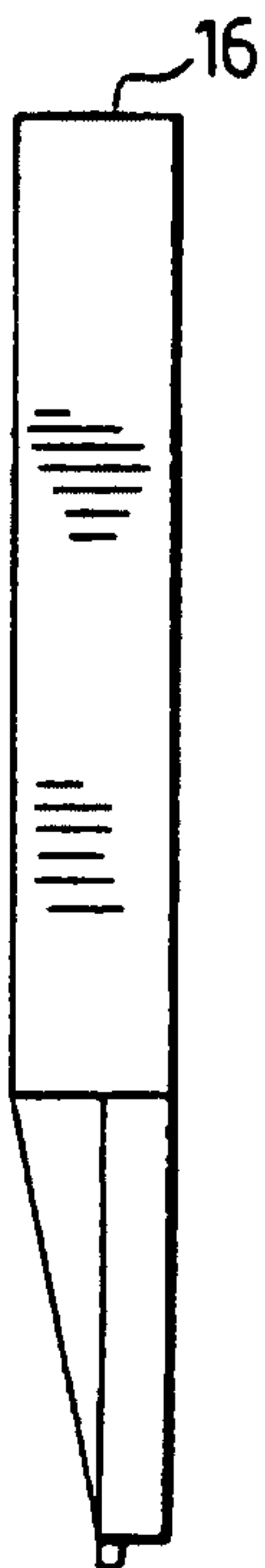

FIG. 32 D

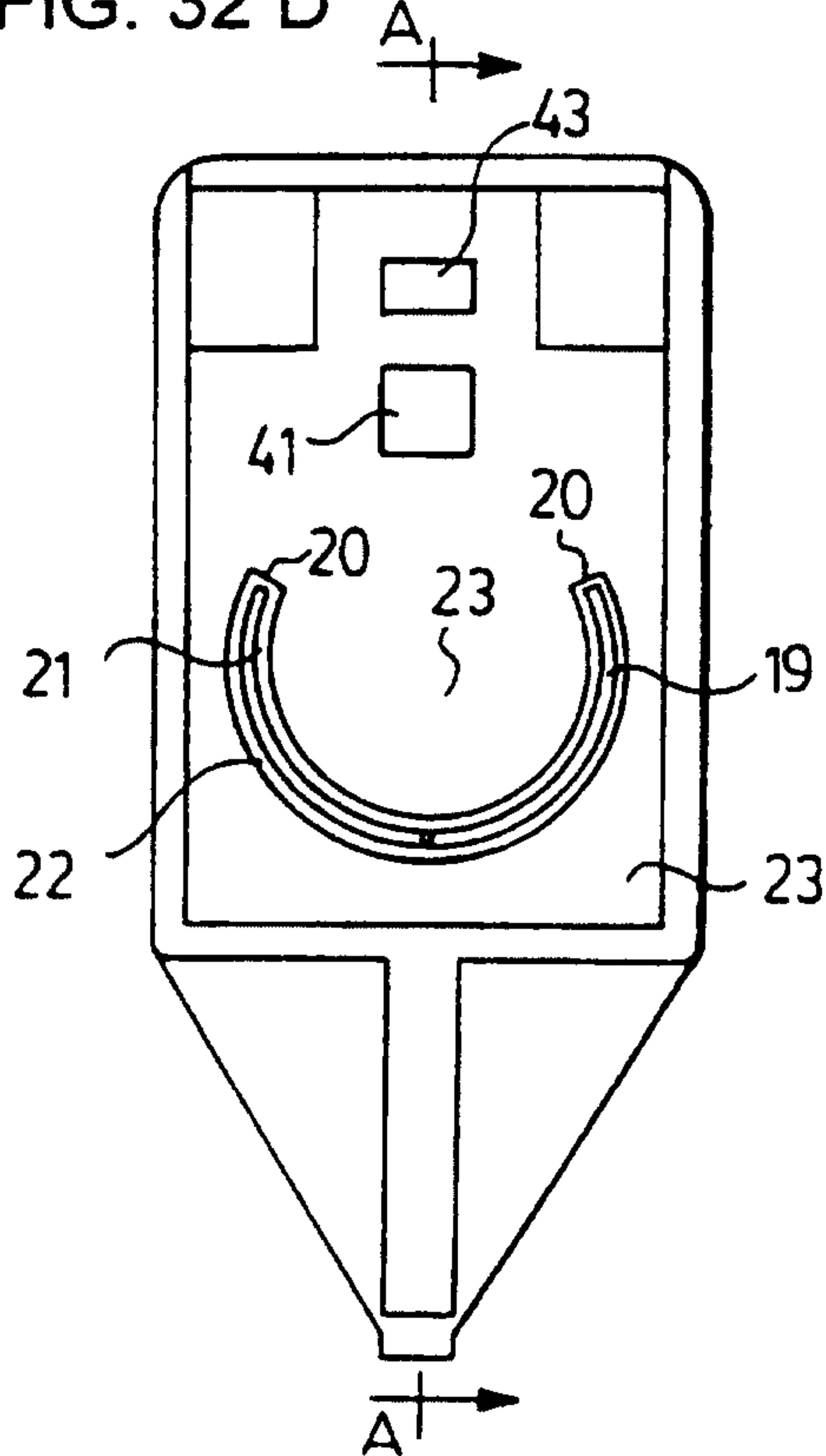

FIG. 32 E

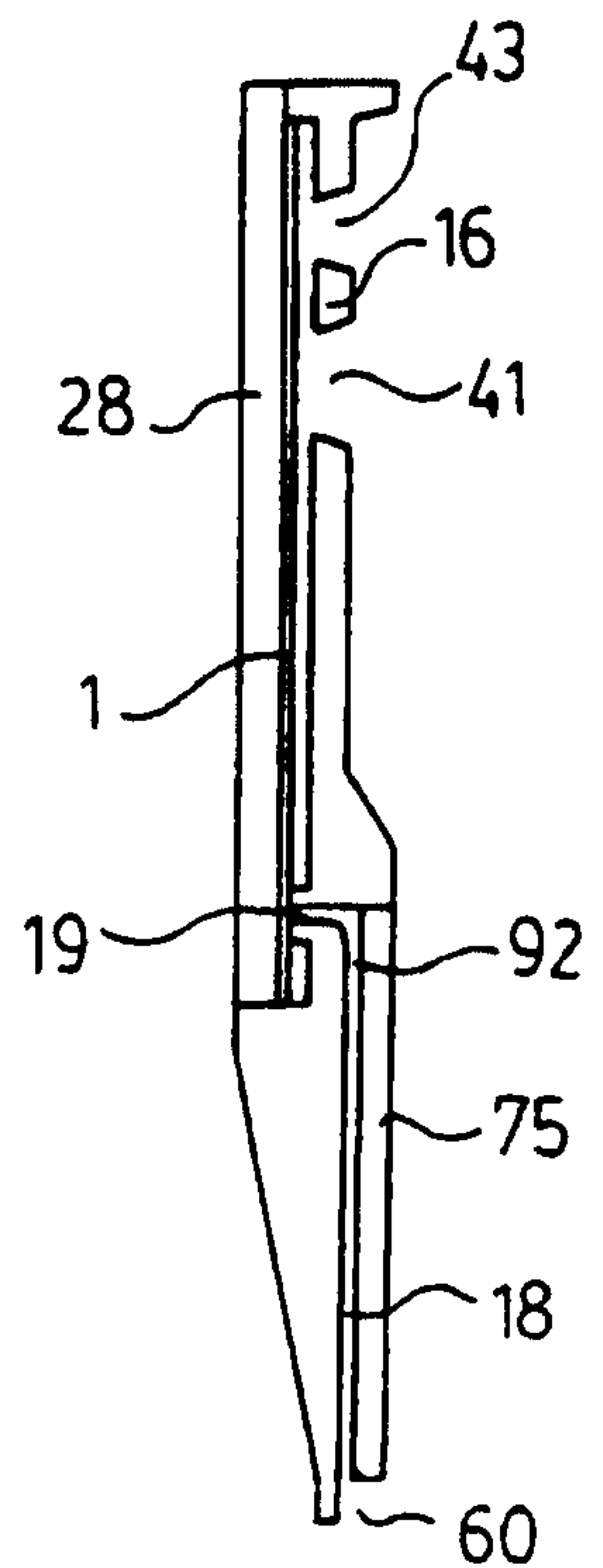

FIG. 33 A

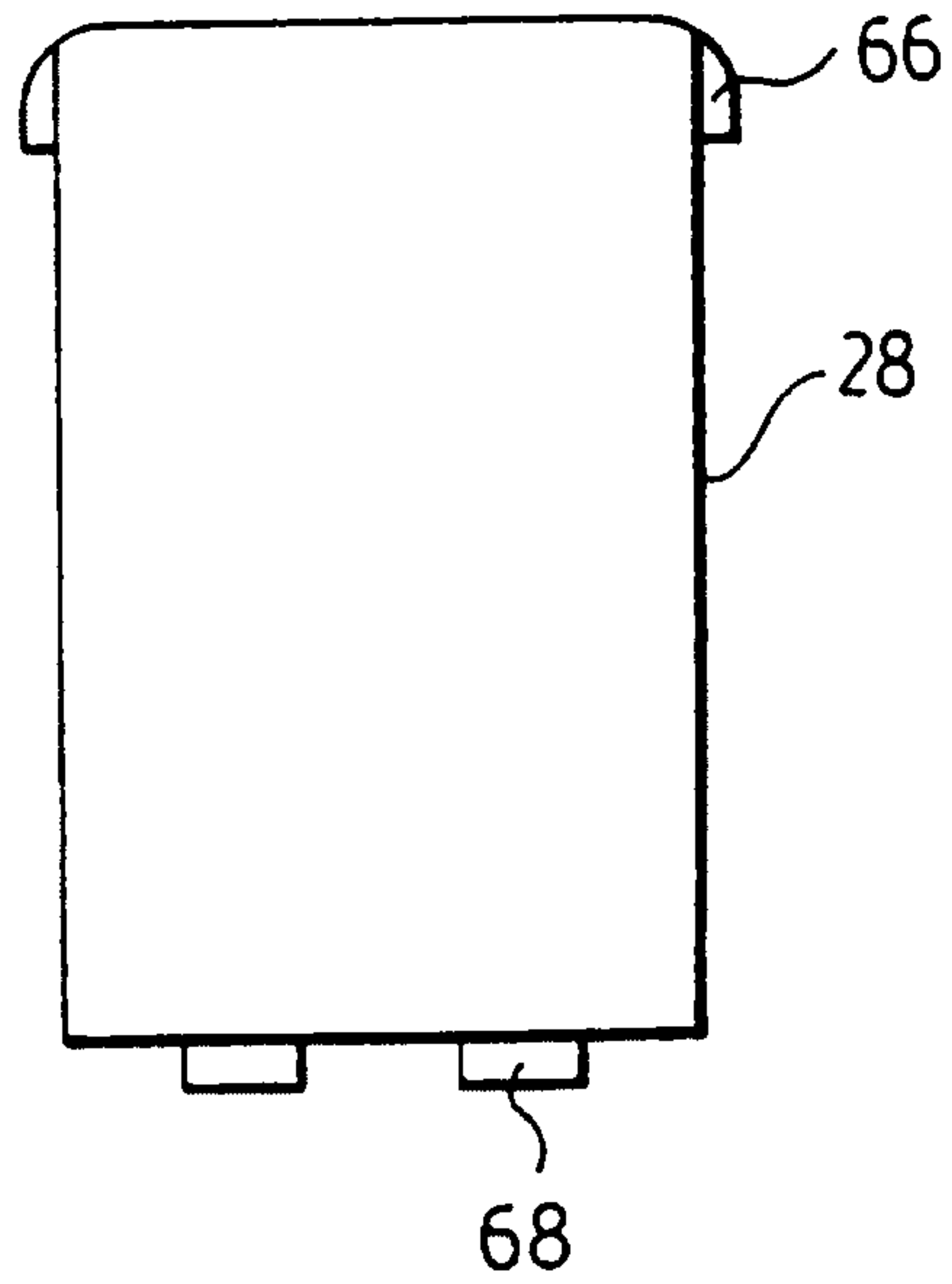

FIG. 33 B

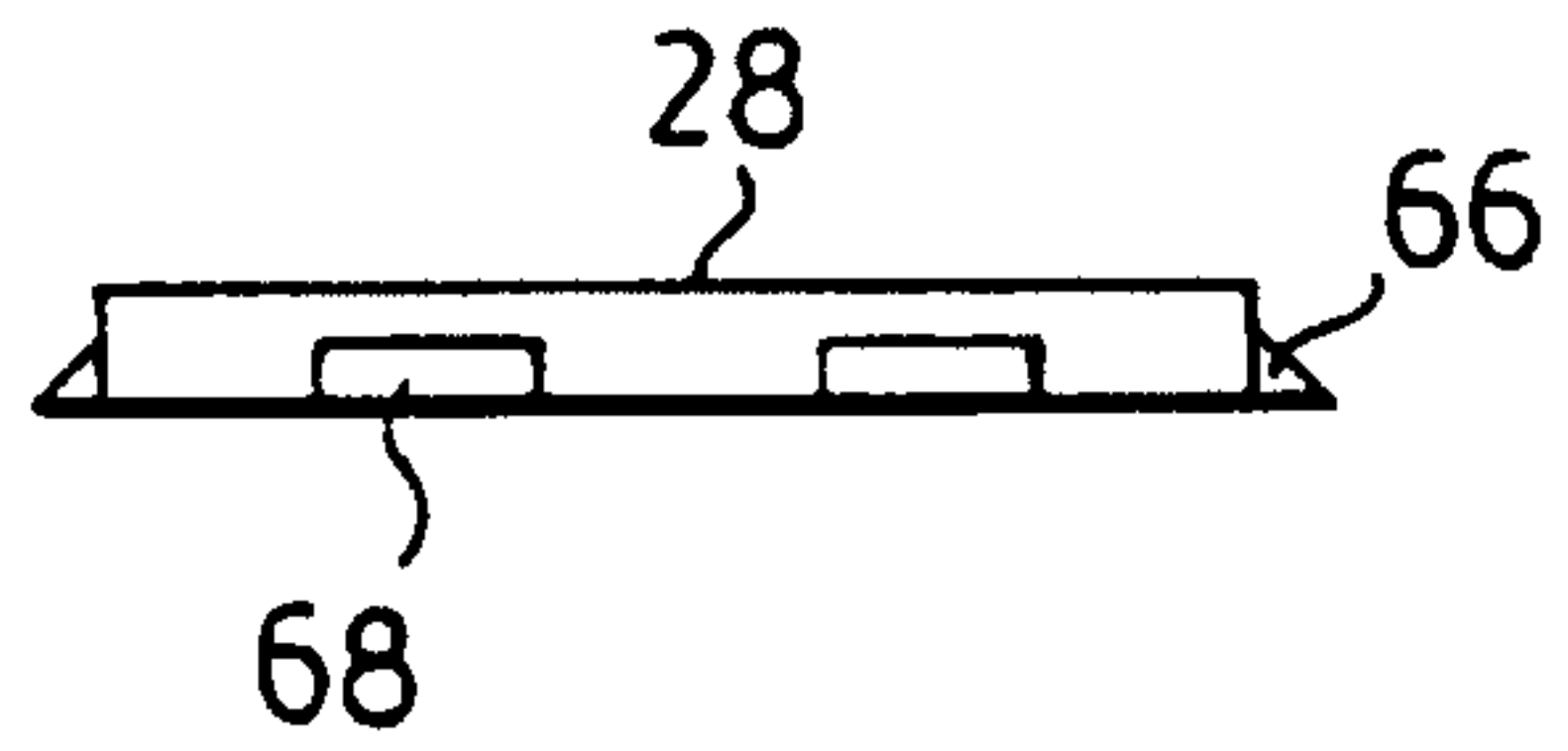

FIG. 33 C



FIG. 34 A

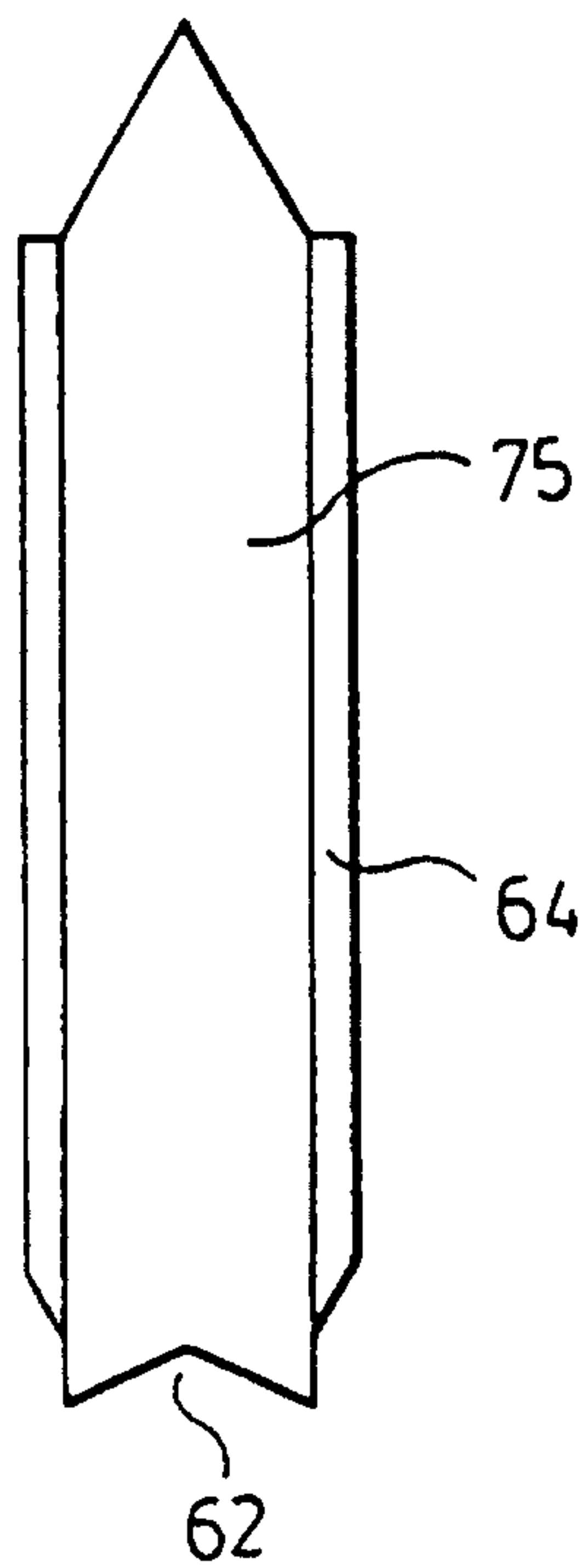
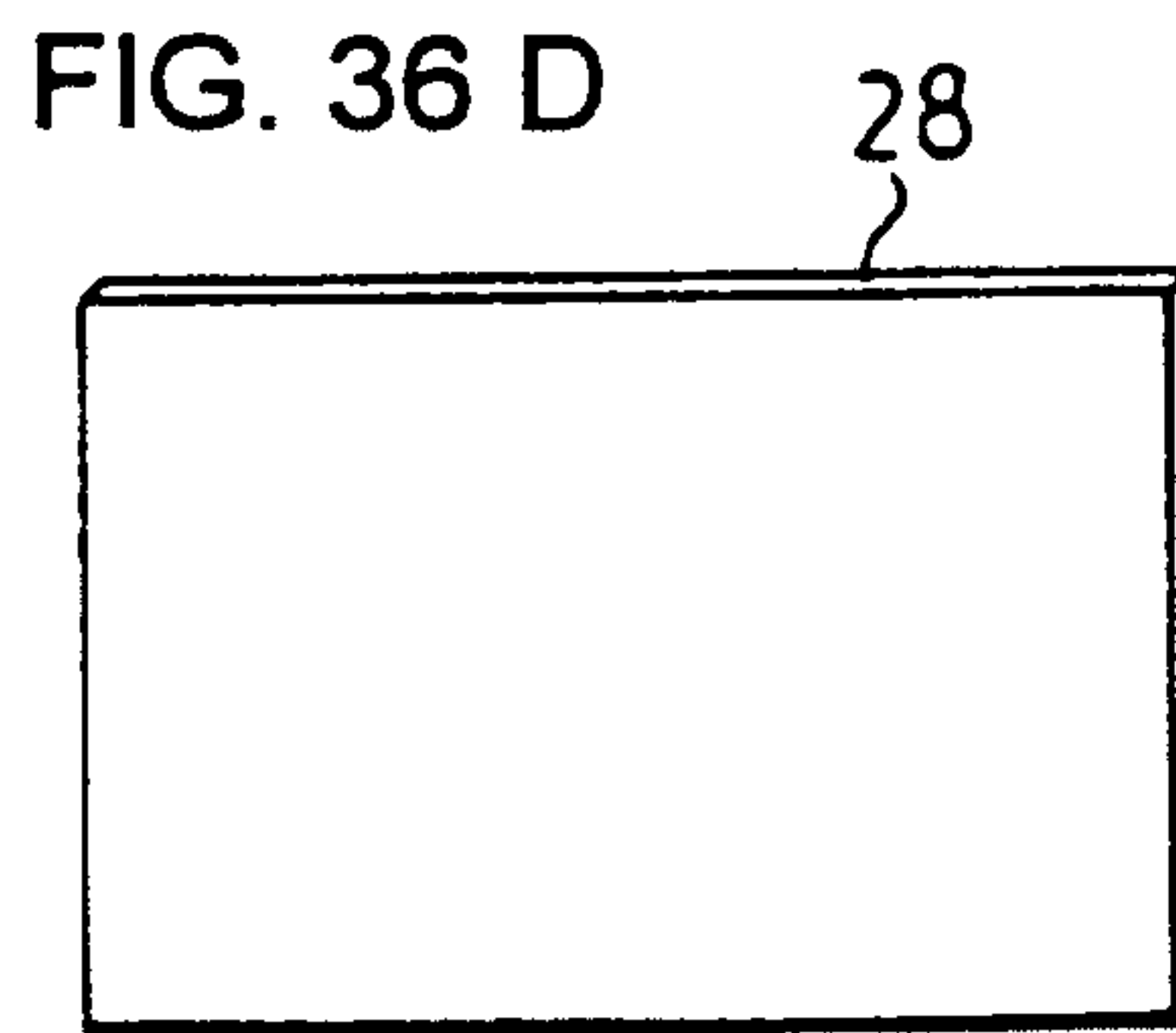
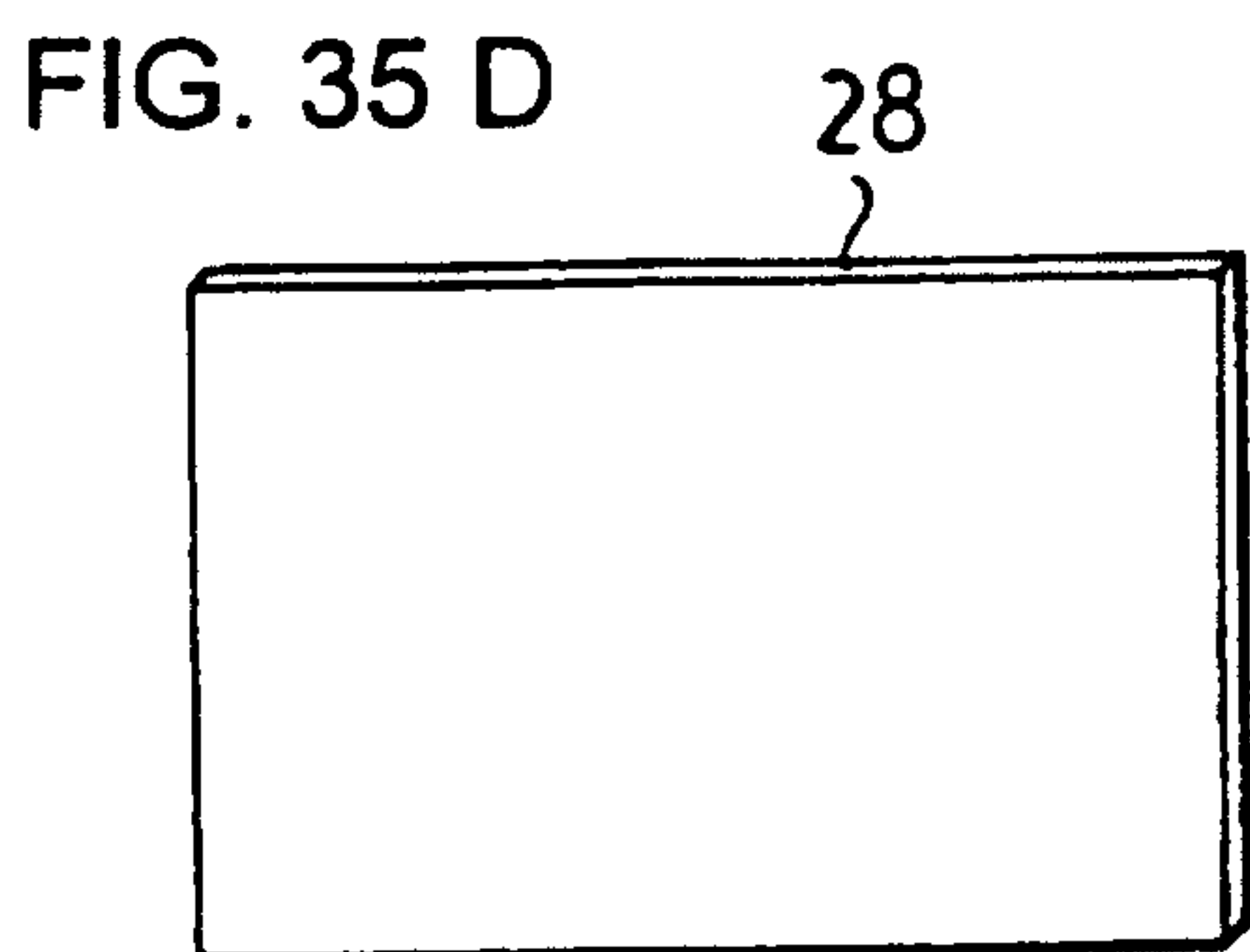
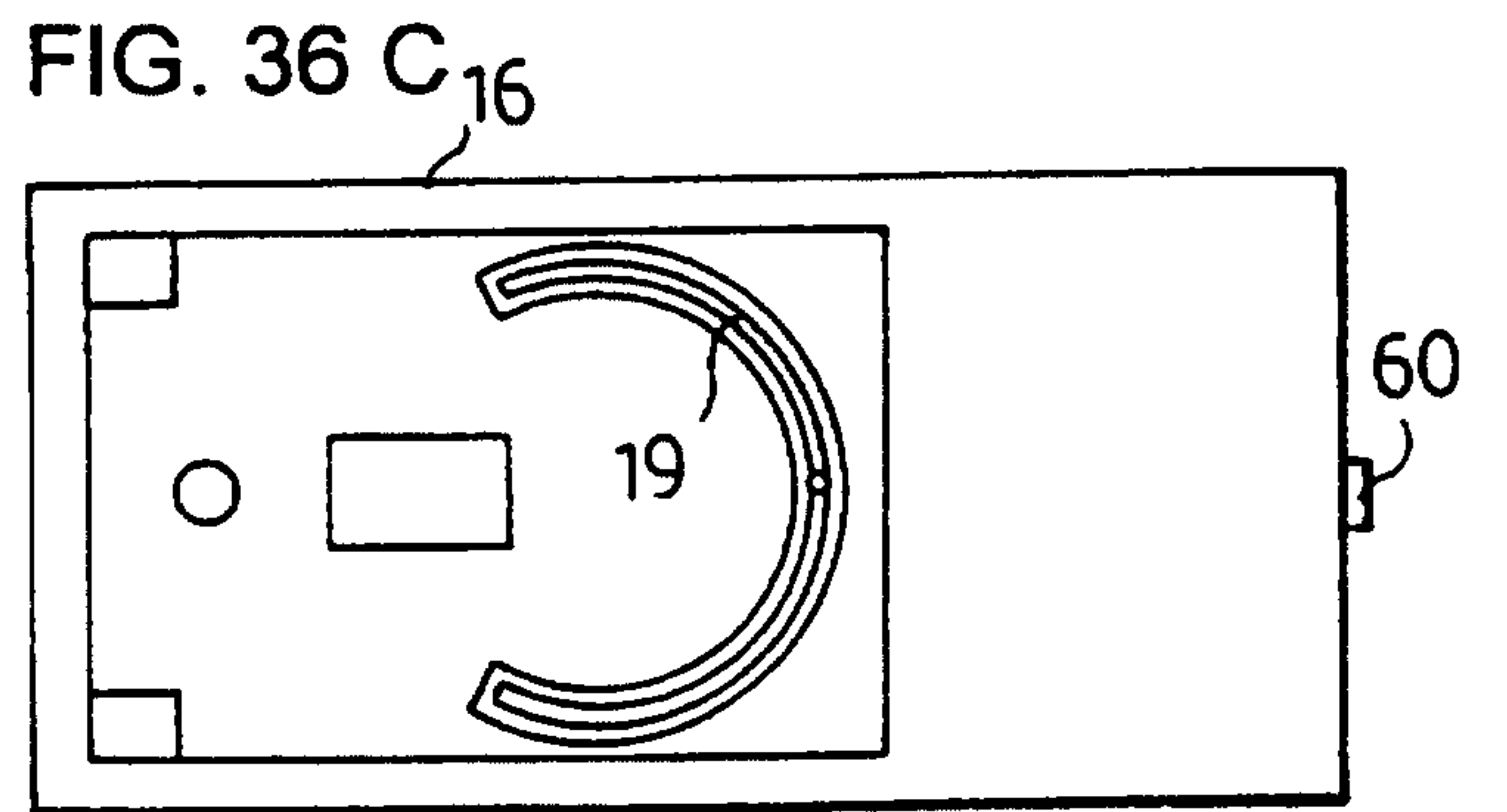
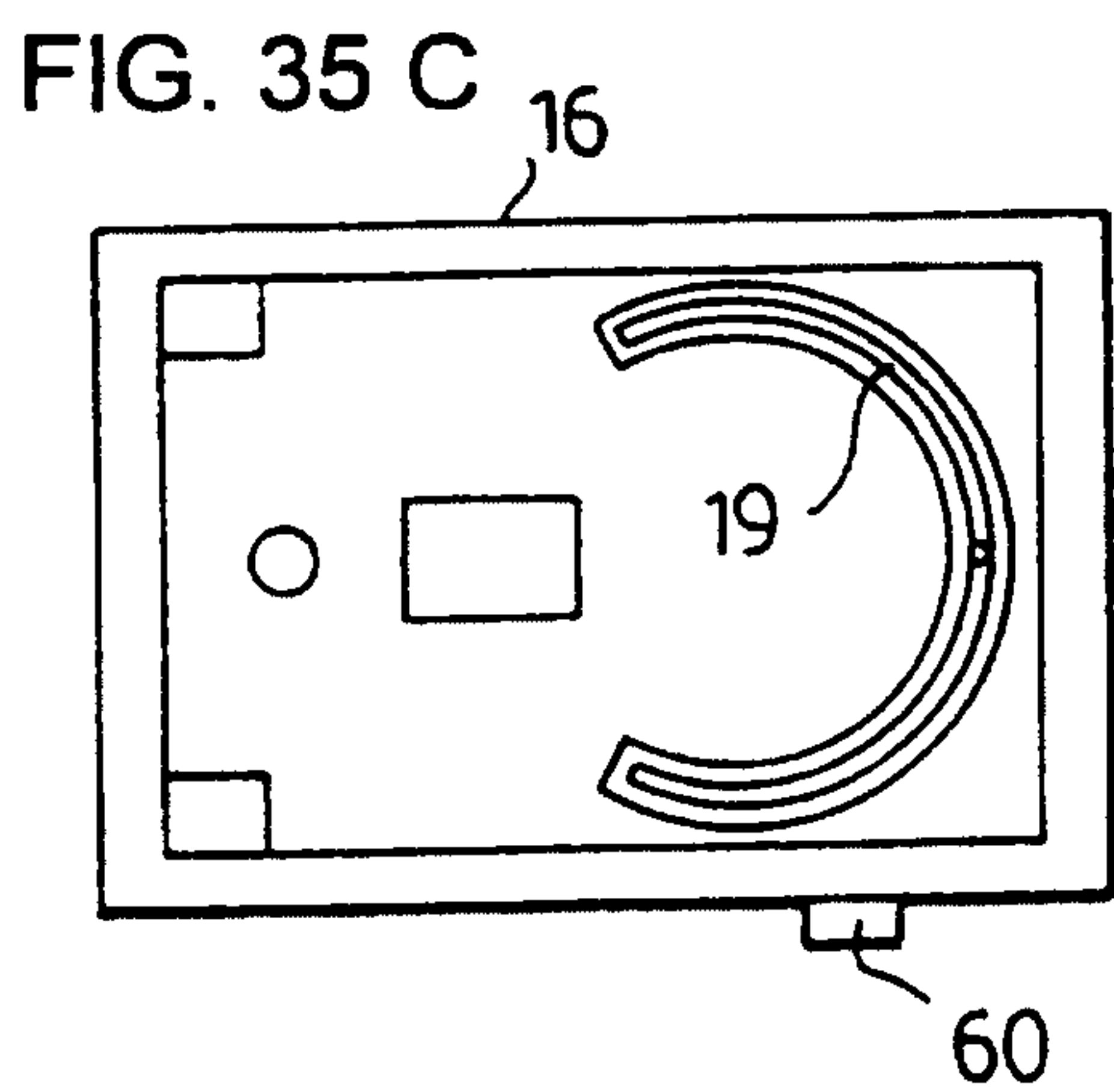
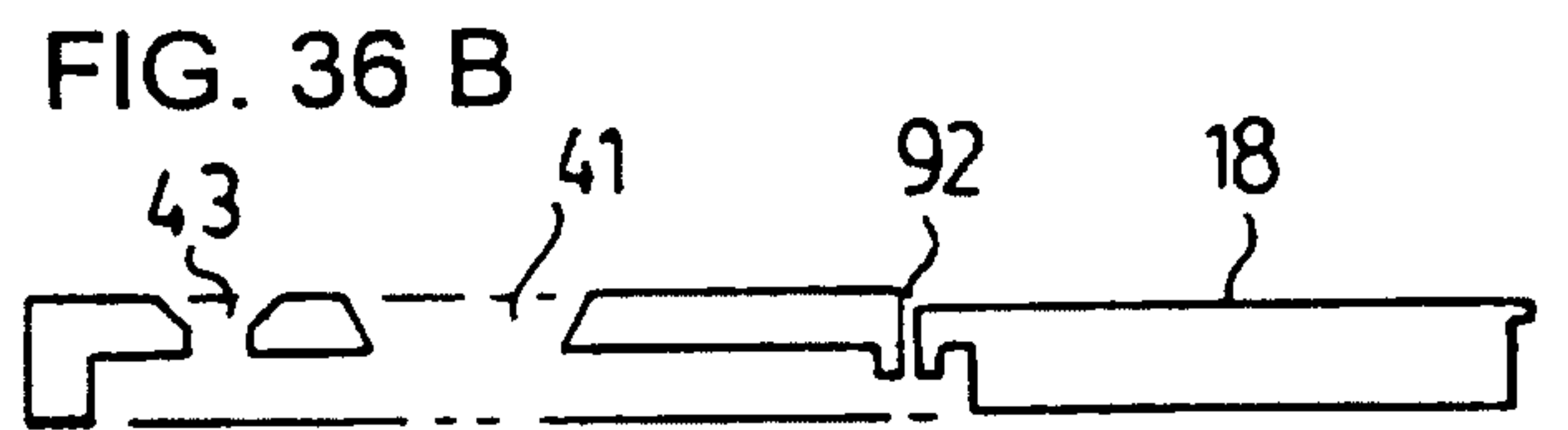
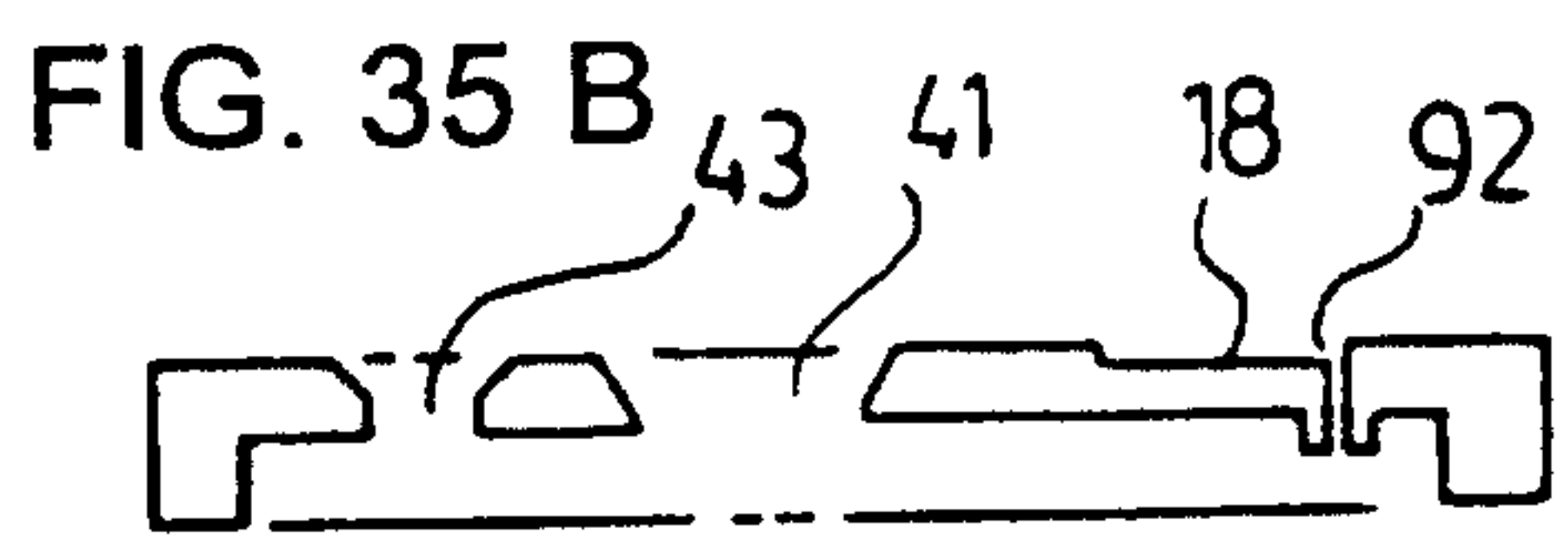
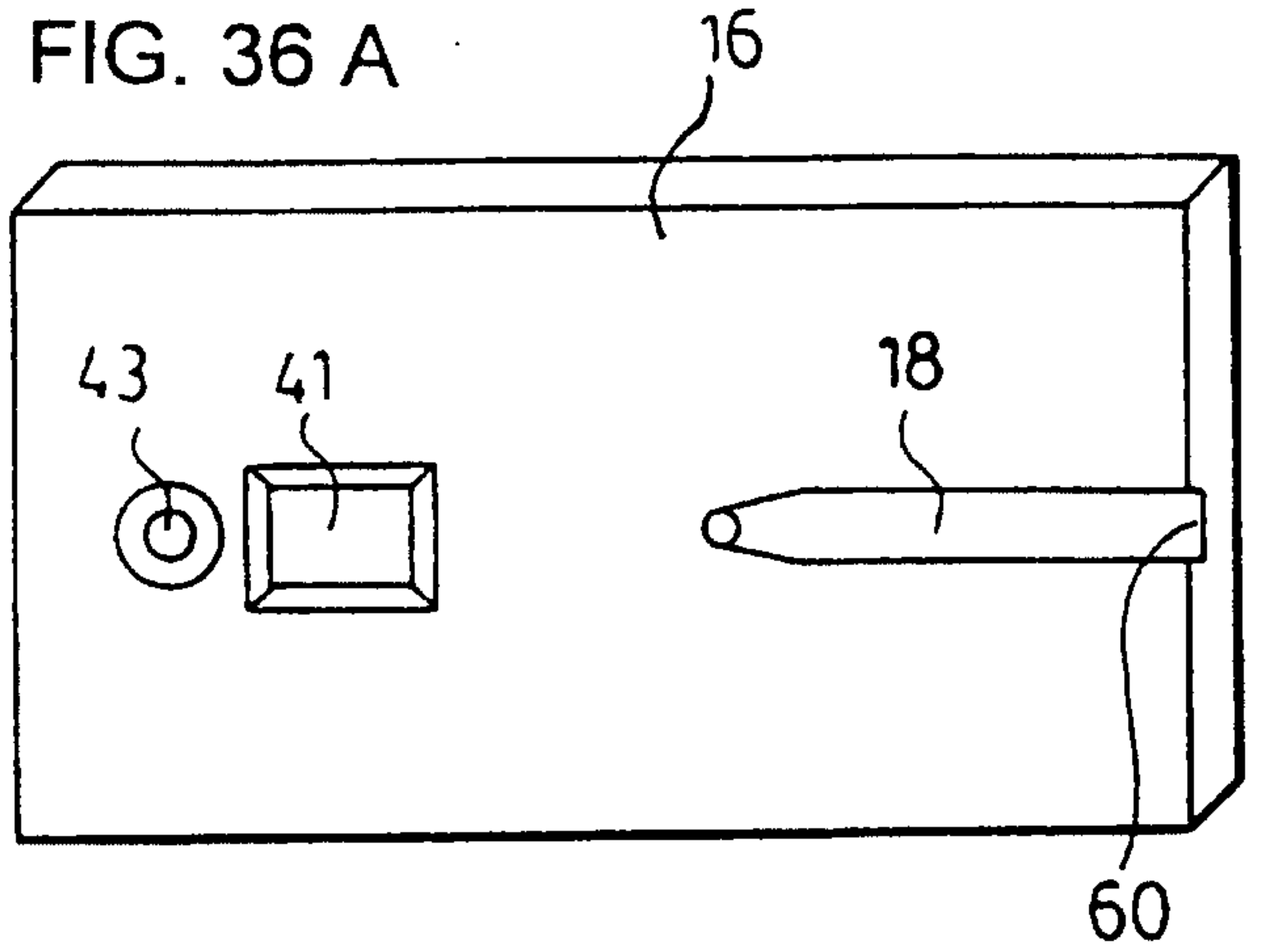
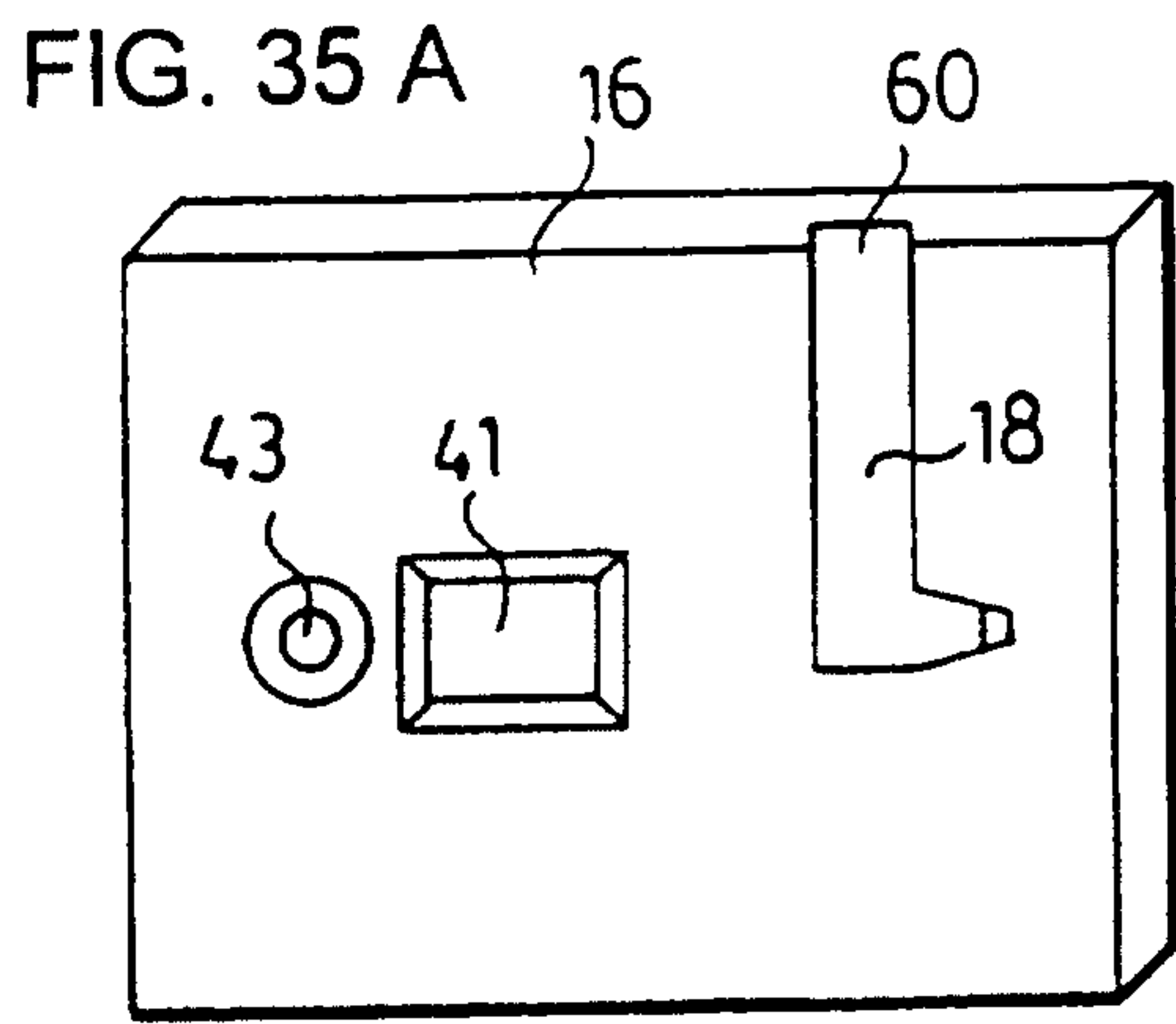

FIG. 34 B



21/25



22/25

FIG. 37

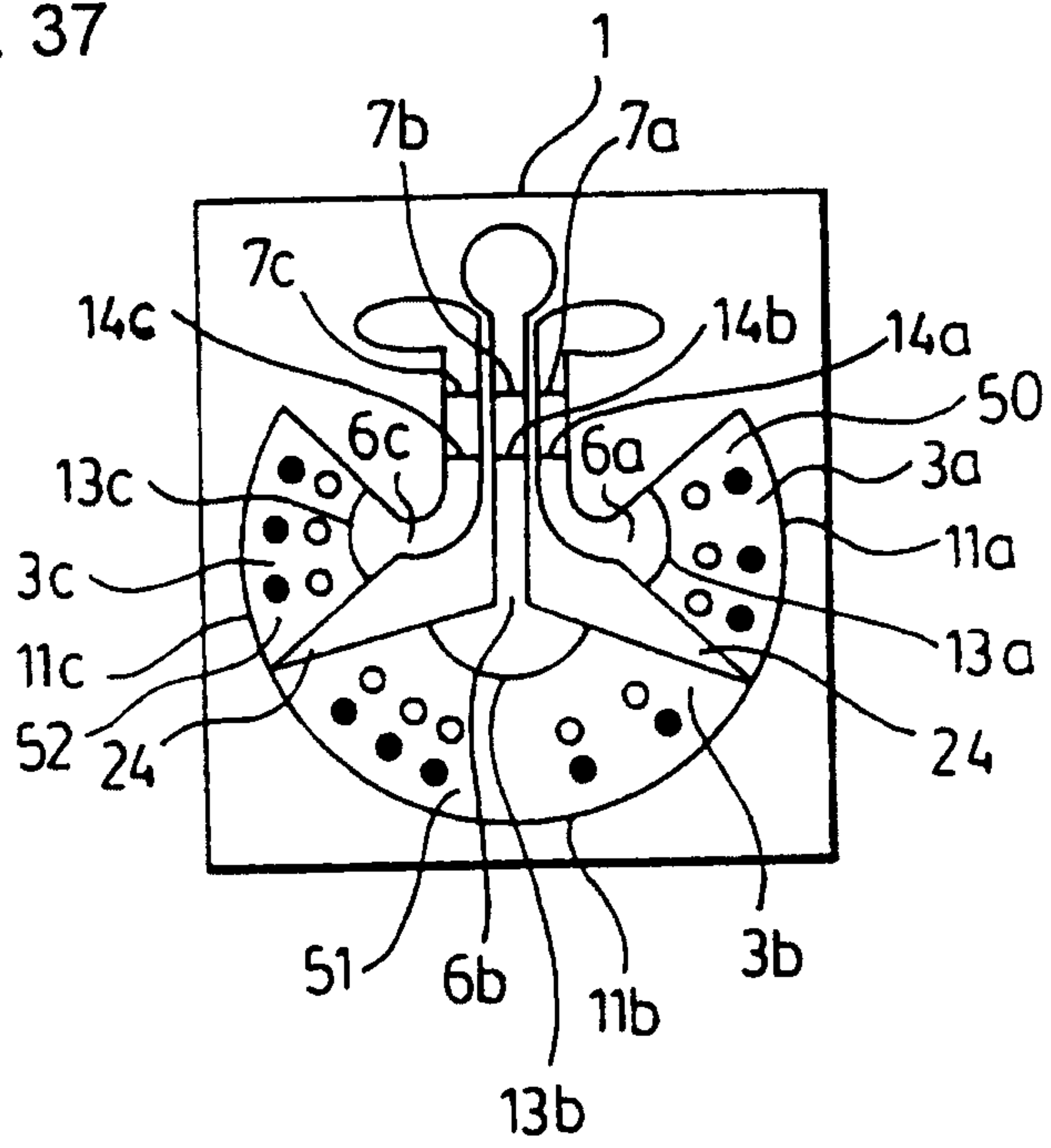

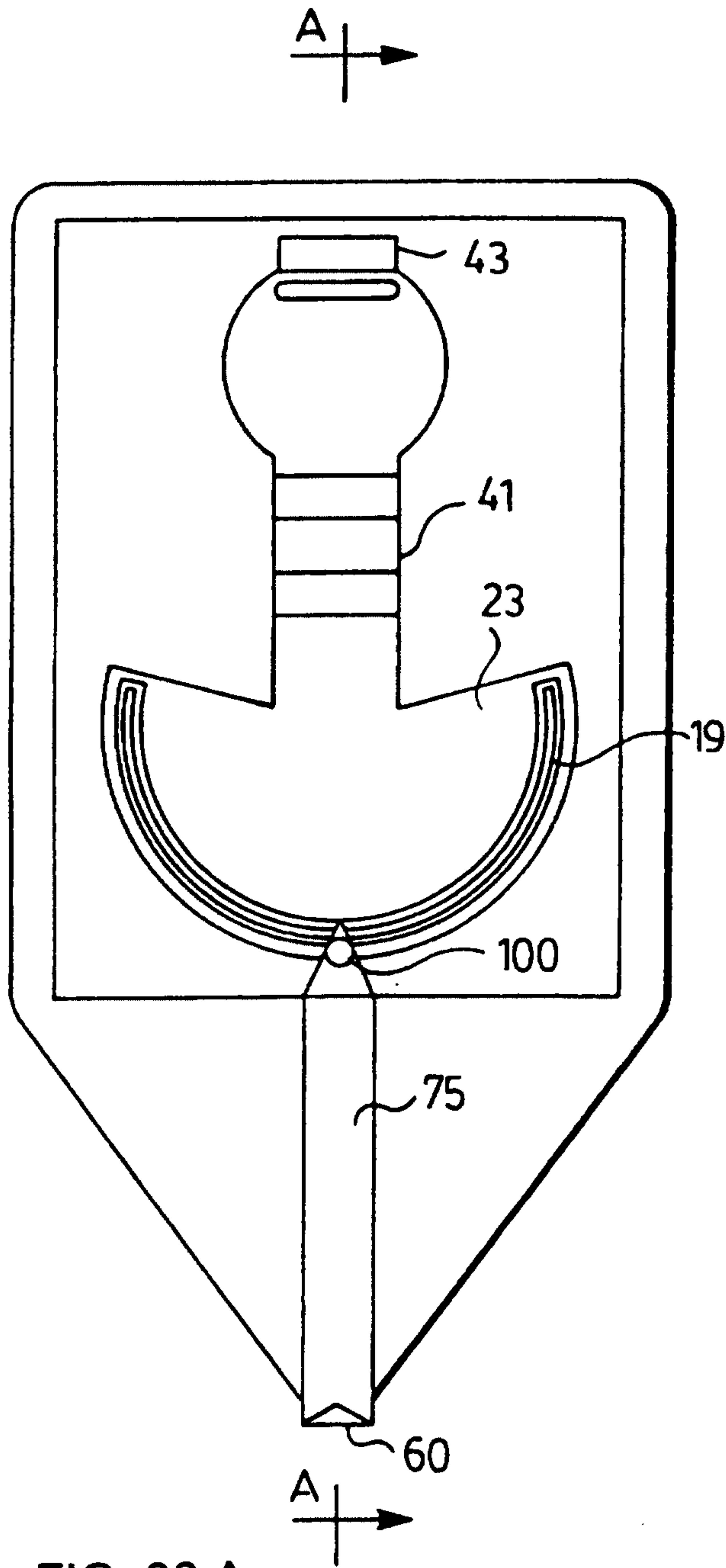

FIG. 38 A

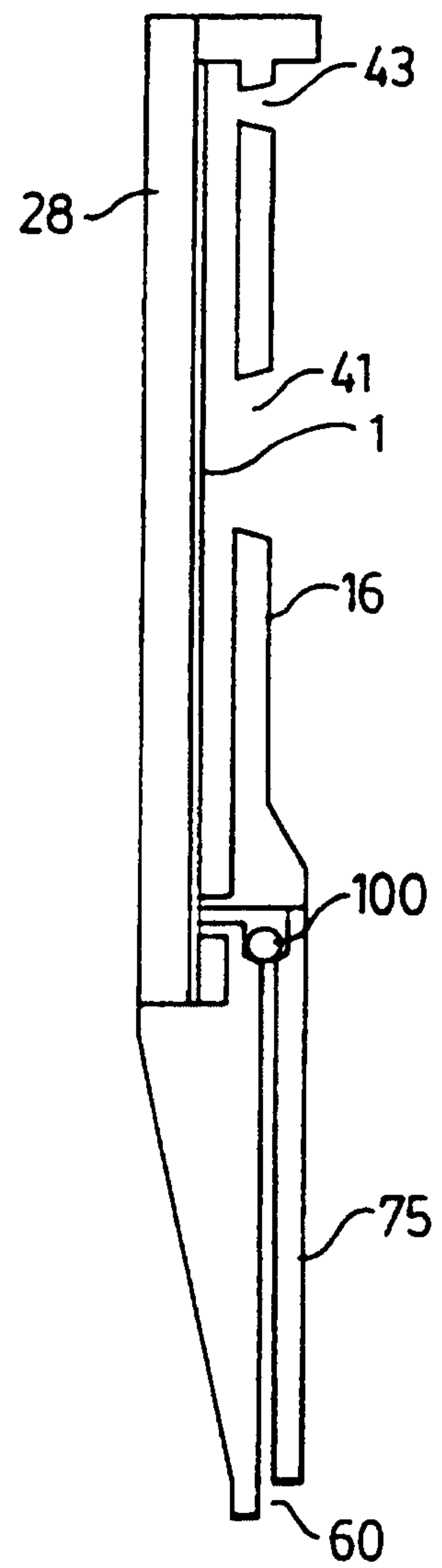

FIG. 38 B

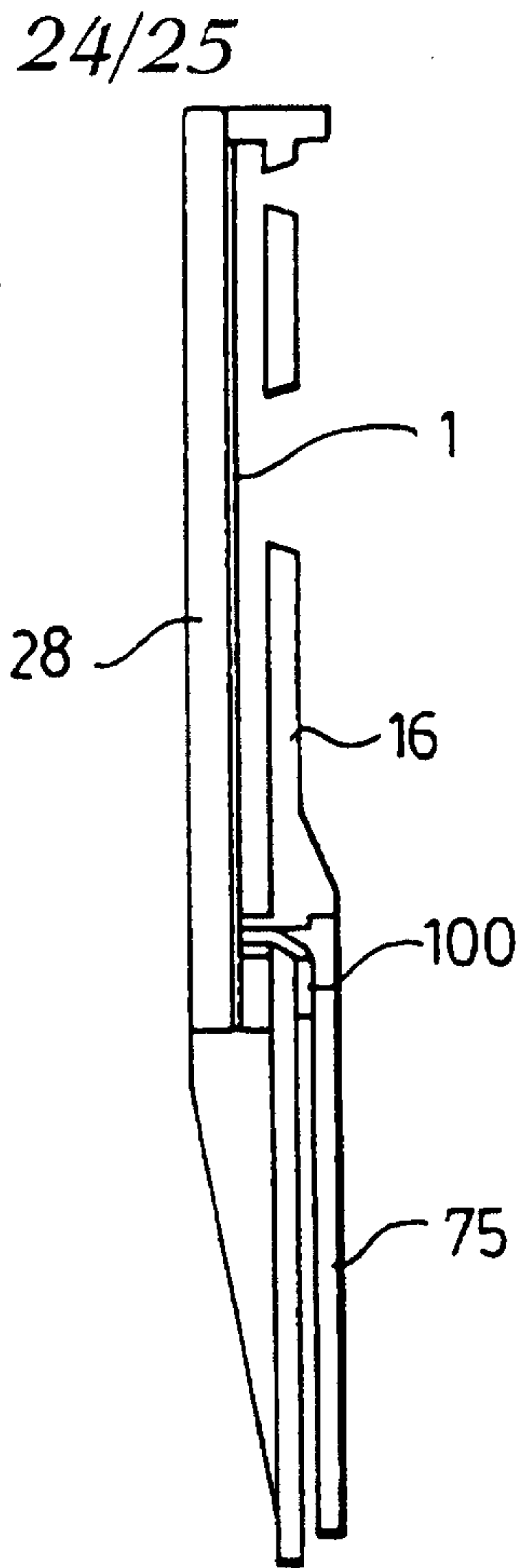

FIG. 40 A

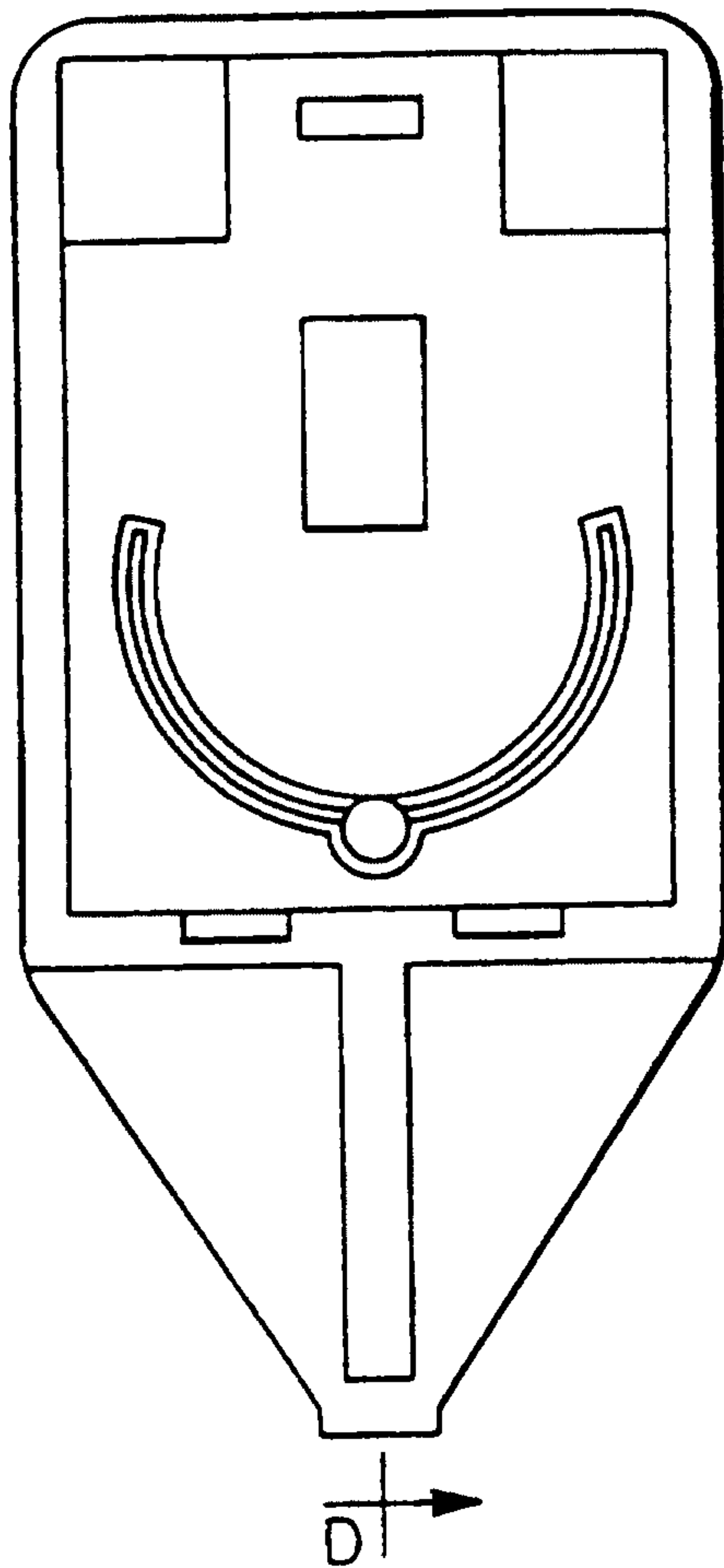
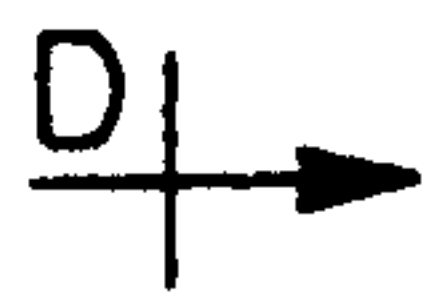

FIG. 40 B



25/25

FIG. 41 A

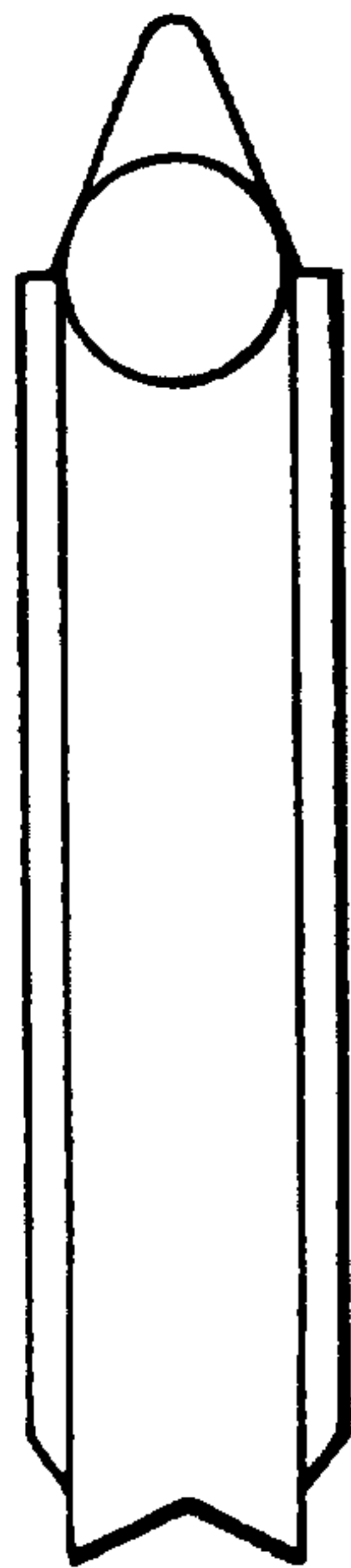

FIG. 41 B

