

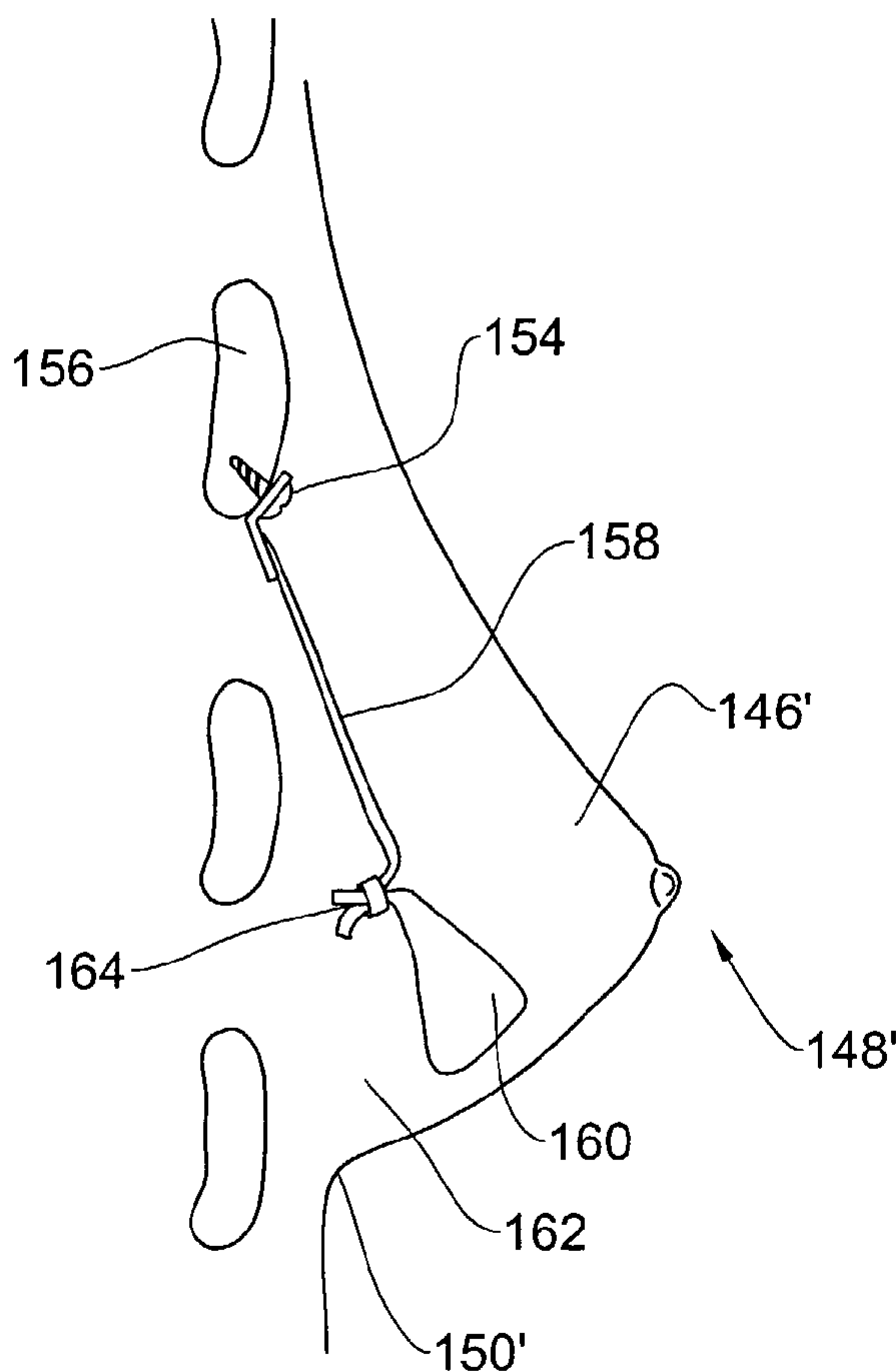

(86) Date de dépôt PCT/PCT Filing Date: 2003/06/11
 (87) Date publication PCT/PCT Publication Date: 2003/12/18
 (85) Entrée phase nationale/National Entry: 2004/12/08
 (86) N° demande PCT/PCT Application No.: IL 2003/000490
 (87) N° publication PCT/PCT Publication No.: 2003/103536
 (30) Priorité/Priority: 2002/06/11 (150151) IL

(51) Cl.Int.⁷/Int.Cl.⁷ A61F 2/00
 (71) Demandeur/Applicant:
MIM-MINIMALLY INVASIVE MASTOPEXY LTD., IL
 (72) Inventeurs/Inventors:
SHFARAM, ADI, IL;
GUR, EYAL, IL
 (74) Agent: BORDEN LADNER GERVAIS LLP

(54) Titre : SYSTEME ET PROCEDE DE REMODELAGE DE LA POITRINE
 (54) Title: SYSTEM FOR BREAST LIFTING



(57) Abrégé/Abstract:

A system and a method and a surgical tool for breast lifting, wherein at least one anchor is fixed to a posture tissue, above a desired nipple level, with one or more suspending members suspended from the at least one anchor and extending through the breast for cradling the breast from below.

(12) INTERNATIONAL APPLICATION PUBLISHED UNDER THE PATENT COOPERATION TREATY (PCT)

(19) World Intellectual Property
Organization
International Bureau



(43) International Publication Date
18 December 2003 (18.12.2003)

PCT

(10) International Publication Number
WO 2003/103536 A3

(51) International Patent Classification⁷: **A61F 2/00**

(21) International Application Number:
PCT/IL2003/000490

(22) International Filing Date: 11 June 2003 (11.06.2003)

(25) Filing Language: English

(26) Publication Language: English

(30) Priority Data:
150151 11 June 2002 (11.06.2002) IL

(71) Applicant and

(72) Inventor: SHFARAM, Adi [IL/IL]; 2 Shalom Aleichem Street, Herzliya Pituach, 46703 Herzliya (IL).

(74) Agent: REINHOLD COHN AND PARTNERS; P.O.Box 4060, 61040 Tel Aviv (IL).

(81) Designated States (*national*): AE, AG, AL, AM, AT, AU, AZ, BA, BB, BG, BR, BY, BZ, CA, CH, CN, CO, CR, CU,

CZ, DE, DK, DM, DZ, EC, EE, ES, FI, GB, GD, GE, GH, GM, HR, HU, ID, IL, IN, IS, JP, KE, KG, KP, KR, KZ, LC, LK, LR, LS, LT, LU, LV, MA, MD, MG, MK, MN, MW, MX, MZ, NI, NO, NZ, OM, PH, PL, PT, RO, RU, SC, SD, SE, SG, SK, SL, TJ, TM, TN, TR, TT, TZ, UA, UG, US, UZ, VC, VN, YU, ZA, ZM, ZW.

(84) Designated States (*regional*): ARIPO patent (GH, GM, KE, LS, MW, MZ, SD, SL, SZ, TZ, UG, ZM, ZW), Eurasian patent (AM, AZ, BY, KG, KZ, MD, RU, TJ, TM), European patent (AT, BE, BG, CH, CY, CZ, DE, DK, EE, ES, FI, FR, GB, GR, HU, IE, IT, LU, MC, NL, PT, RO, SE, SI, SK, TR), OAPI patent (BF, BJ, CF, CG, CI, CM, GA, GN, GQ, GW, ML, MR, NE, SN, TD, TG).

Published:

- with international search report
- before the expiration of the time limit for amending the claims and to be republished in the event of receipt of amendments

[Continued on next page]

(54) Title: SYSTEM FOR BREAST LIFTING

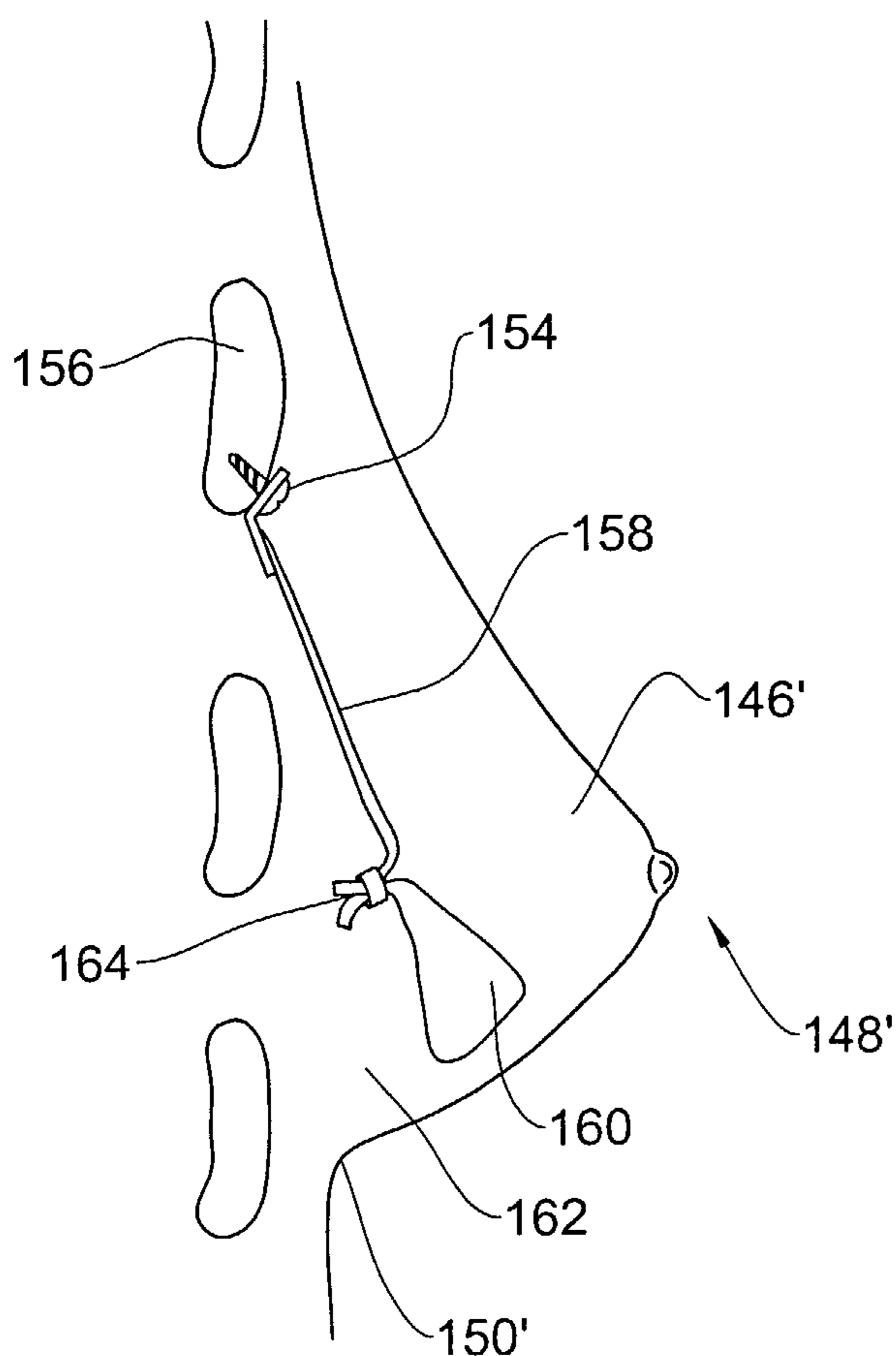

(57) Abstract: A system and a method and a surgical tool for breast lifting, wherein at least one anchor is fixed to a posture tissue, above a desired nipple level, with one or more suspending members suspended from the at least one anchor and extending through the breast for cradling the breast from below.

WO 2003/103536 A3

WO 2003/103536 A3



(88) Date of publication of the international search report:
29 January 2004

For two-letter codes and other abbreviations, refer to the "Guidance Notes on Codes and Abbreviations" appearing at the beginning of each regular issue of the PCT Gazette.

SYSTEM AND METHOD FOR BREAST LIFTING

FIELD OF THE INVENTION

The present invention is generally in the field of breast shape correction and more specifically it is concerned with breast lifting.

The system according to the present invention may be applied only for the purpose of breast lifting, where the shape of a female's breast is altered or revised, without carrying out a surgery, i.e. only effecting the actual shape of the breasts, without removing breast tissue and without augmentation (adding implants of any type). However, the system may also be applied in conjunction with breast augmentation or breast size reduction, which are surgical procedures.

BACKGROUND OF THE INVENTION

Over the years, factors such as pregnancy, nursing, and the force of gravity take their toll on a woman's breasts. This situation is known as *ptosis* and is defined as a situation at which the nipple-areola complex projection is lower than the infra-mammary fold, i.e. the nipple is below the level of the lower breast crease.

As the skin loses its elasticity, the breasts often lose their shape and firmness and begin to sag, obtaining a teardrop like shape rather than a cone-like shape. Breast lifting, also referred to by the alternative names *mastopexy* and *mammoplasty*, is a procedure used for reshaping saggy and loose breasts, elevating the nipple and areola to a higher level and, thus affording the breast its former shape and firmness which can result in a revitalized body image that can bolster a woman's self-esteem.

Many women use a push-up bra to support their breasts. This however is at times uncomfortable and may be restricting as far as the selection of clothing.

- 2 -

Mastopexy procedure according to prior art techniques involves reducing ptosis (sagging of the breast caused by stretched skin, in many cases due to a great loss of breast tissue). During a breast lift, long incisions are made along the natural creases in the breast and around the dark skin surrounding the nipple (areola), a keyhole-shaped incision above the areola is also made to define the new location for the nipple. Excess skin is removed from the lower section of the breast and the areola, nipple, and underlying breast tissue are repositioned up to a higher position. The nipple is moved and incisions are closed with sutures.

Several methods for performing a mastopexy are known, and the technique opted for depends mainly on the amount of breast and fat tissue, the amount of skin to be removed, symmetry in volume of breasts and size of areolas, and choice and taste of patient. Since the procedure involves surgery, it may be coupled with breast augmentation and with resizing or repositioning of the areola to a more aesthetically pleasing position and the shape of the mound may be improved by placement of breast implants. Occasionally, only a one-sided breast lift is required, when the other breast is in a reasonable position on the chest and does not require a breast lift.

U.S. Patent No. 5,676,161 to Breiner discloses a mastopexy procedure according to which an anchor-shaped incision is made, having a bottom line along the infra-mammary crease, using a circular cutter to form the top portion of the incision and an incision around the areola to reduce the diameter thereof. After removing excess skin inside the incision, and breast tissue in the case of mammoplasty, shifting the areola, nipple and underlying breast tissue upward to position the areola/nipple complex within the circular top portion, pulling the flaps of skin formed to the sides of the incision down and around the areola and underneath same, and then suturing adjacent skin edges to complete the lifting and reshaping.

U.S. Patent No. 5,584,884 to Pignataro discloses a mammary prosthesis comprising a wedge shaped sheet of flexible biocompatible material having reinforced upper and lower attachment portions for attachment to bone of a patient

- 3 -

by bone anchors, with the lower attachment portion being anchored to one or more ribs. The lower attachment portion includes a support member less flexible than the sheet material having suture receiving openings for receiving bone anchor sutures.

U.S. Patent No. 5,217,494 to Coggins *et al* discloses a prosthesis for
5 supporting tissue which among others may be used also in a breast lift procedure, wherein one end of the prosthesis is implanted deep into the breast tissue and the opposed end is attached to either the clavicle or the rib.

These procedures are typically performed under general anesthesia, though at times local anesthesia is sufficient, and they may last several hours, depending on
10 the extent of the surgery.

As with any surgery, there is always a possibility of complications such as a reaction to the anesthesia, bleeding and infection (which may cause scars to widen). Mastopexy does leave noticeable, permanent scars, although are so planed as to be concealed by a woman's bra or bathing suit. One may expect that after about one
15 year the scars will hardly be noticeable. As far as aesthetics, there may also be some unsatisfactory, as the final appearance may not always meet the patient's expectations. Evermore, a breast lift performed according to conventional techniques won't keep firm forever, the effects of gravity, pregnancy, aging, and weight fluctuations will eventually take their toll again.

It is an object of the present invention to provide a novel system and a
20 method for breast lifting, wherein the above drawbacks are significantly reduced or overcome. The system according to the invention and the method for carrying it out are minimal invasive and may be considered as non-surgical, i.e. they do not involve incisions (but rather two or four stab incisions) and removal of excess skin,
25 nor do they require stitches. However, the system may also be used in conjunction with breast enlargement (breast augmentation with mastopexy) or breast size reduction, which are surgical procedures.

- 4 -

SUMMARY OF THE INVENTION

The present invention provides a system for breast lifting, wherein one or more anchors are fixed to a posture tissue, above the desired nipple level with one or more suspending members cradling the breast and extending from the one or
5 more anchors, such that tensioning the suspending members entails lifting of the breast.

The posture tissue is preferably a bone (ribs or collar bone), though it may also be a muscle tissue (pectoral or intercostals). For each breast anchors may be fixed to one or more posture, depending on the physiology/anatomy of the patient,
10 the shape of the breast prior to lifting, and the desired lifting result. An anchor may be a bolt fixture or a threaded fixture Typically but not restricted thereto, a self tapping screw) for screw-fixation into a bone, a suspending hook for bearing from a bone, i.e. clinging from the bone, or a clasp formed with hooks for grasping soft tissue (muscle). Alternatively, where the posture tissue is a mussel, the suspension
15 member may be fixed thereto by stitching. According to still an alternative, the suspension member may be attached to a bone by tying or yarning it through a bore formed through the bone.

A suspension member according to the invention may be a tendon-like wire or a mesh, made of organic material (e.g. tendons), or synthetic material (e.g.
20 silicone, Gortex™, etc.).

According to a preferred embodiment of the invention, the suspension member is formed with or comprises a cradling portion or a cradling member respectively, having increased surface area then the suspension member, for supporting the breast from below and padding it, said cradle being a mesh, a strap
25 or a tube-like member mounted on a wire-like suspension member.

A significant advantage of the present invention, apart for the fact that it is a so called minimal invasive procedure, is that the aesthetic results and appearance may be modified to match with customer's expectations during, or any time after the procedure, i.e. corrections may be easily effected after a while (typically several
30 years), if *ptosis* reoccurs.

- 5 -

The proposed procedure approves well with other medical procedures and may be combined with breast enlargement (augmentation) or breast reduction. Even more so, the procedure is completely reversible. Apart from that the procedure is fast and relatively inexpensive, and the patient is dismissed shortly
5 after, leaving practically no scars.

The procedure according to the present invention is carried out by inserting a tool through one or two locations at a bottom face of the breast, directed towards the posture tissue such that it passes through the breast tissue. The tool is used for fixing the anchor to the posture, and according to an embodiment thereof, the tool
10 is also used for guiding and manipulating the suspension member so as to cradle the breast and then tensioning the suspension member at the required extent.

In some cases, depending among others on breast size, two sets of such system may be required for a breast, so as to improve the under support.

According to a further aspect of the present invention there is provided a
15 method for breast lift, said method comprises the following steps:

- a) introducing through the breast at least one anchor and fixing it to a posture tissue;
- b) yarning a suspension member through the breast; said suspension member extending from said at least one anchor and passing within fat
20 tissue at a bottom portion of the breast so as to cradle the breast;
- c) tensioning the suspension member to thereby lift the breast; and
- d) fixating the length of the suspension member.

An alternative method comprises the following steps:

- a) yarning a cradling member of a suspension member through the breast,
25 at a bottom thereof, such that loose ends thereof extend from the breast;
- b) fixing at least one anchor to a posture tissue, at a level above the desired nipple level;
- c) attaching a suspension member to the at least one anchor;
- d) articulating the loose ends of the cradling member to the suspension
30 member and fixedly adjusting the length thereof.

- 6 -

According to a preferred embodiment, two anchors are fixed to the posture tissue, with a suspension member extending from each one, such that the loose ends of the cradling member are articulated to each respective end of a suspension member. Still preferably, excessive ends of the suspension members and of the
5 cradling member, are trimmed.

The method according to an embodiment thereof further comprises fitting a cradle member on the suspension member, for supporting the breast from below. According to one application, the cradle member is a strap-like portion (possible a mash-like material) continuously extending from the suspension member.
10 According to a different application, the cradle member is integral with or mounted over a supplementary member fixedly attached to the suspension member, whereby the breast height is set by adjusting the relative length of the suspension member and the supplementary member.

Where the system is used in conjunction with a breast enlarging procedure,
15 the cradling portion may directly support the implant.

The present invention has several significant advantages, namely:

- a) the mere incisions are two or four stab incision, which are fast healing and practically leave no scars;
- b) the procedure is considerably shorter than any prior art procedure;
- 20 c) the procedure may be carried out under local anesthesia, whereby the patient may be dismissed shortly after;
- d) the procedure is adjustable and reversible at any time;
- e) the procedure is considerably cheaper than any prior art procedure; and
- f) the procedure does not effect sensitivity of the breast or nipple and does it
25 have any consequences concerning breast feeding.

For carrying out the procedure of the present invention, there is provided a tool kit which depending on the specific procedure will include one or more of the following tools:

- a) tool for stabbing the breast and yarning a cradling member there
30 through, such that its free ends extend from the breast; the same tool

- 7 -

may be used for creating a passage through the breast for the suspension member;

- b) tool for deploying and fixing the anchors to a posture tissue (bolting or screwing in the case of a bone posture; stitching in the case of muscle tissue); this tool is also used for yarning the suspension member which is articulated to the anchor;
- c) tool for articulating and tensioning ends of the cradling member to the suspension members, and for adjusting the length, fixating and trimming excessive ends.

10 However, according to different applications, rather than using a tool, slack end of the cradling member and the corresponding slack end of the suspension member, may be manually tensioned and tied to one another, their ends being trimmed by conventional means.

The present invention further calls for a tool useful in carrying out a procedure according to the invention, said tool adapted for tensioning and clamping cord-like slack ends of the cradling member and a corresponding suspension member; said tool comprising a housing fitted at a fore end with a cord receiving opening for receiving two or more two or more cords, a clamp deploying mechanism for clampingly articulating the at least two cords, and a cord trimming mechanism for trimming the cords adjacent the clamp.

25 According to another aspect of the present invention there is provided a kit for performing a breast-lift procedure, the kit comprising at least one set of suspension members, anchoring means for anchoring a suspension member to a posture tissue, and means for tensioning and fixating the suspension member. The kit may also comprise one or more breast-cradling/padding members and one or more tools, e.g. a tool to facilitate tensioning clamping and trimming of a suspension member and a cradling member.

BRIEF DESCRIPTION OF THE DRAWINGS

In order to understand the invention and to see how it may be carried out in practice, some embodiments will now be described, by way of non-limiting examples only, with reference to the accompanying drawings, in which:

5 **Fig. 1** is a partially sectioned side view illustrating the anatomy of an erect, firm breast;

Figs. 2 is a side view illustrating a saggy breast;

Figs. 3A to 3H are consecutive steps of carrying out a breast lift procedure according to a first embodiment of the present invention;

10 **Figs. 4A to 4G** are consecutive steps of carrying out a breast lift procedure according to a second embodiment of the present invention;

Fig. 5A is a side section through a saggy breast prior to breast lift;

Fig. 5B is a side section through the breast in Fig. 5A, after breast lift;

15 **Fig. 6** is a front view of a female body, superimposing how the breasts are supported by two suspension members;

Figs. 7A to 7C are schematic side views illustrating different embodiments of anchoring means; and

Figs. 8A to 8D illustrate a surgical tool useful in carrying out a breast-lifting procedure, in four consecutive operative positions.

20 DETAILED DESCRIPTION OF THE INVENTION

The breast **10** seen in Fig. 1 is firm and erect though of small size. One can notice that the nipple **12** is facing forward and that the nipple-areola complex projection is lower than the infra-mammary fold **16**, i.e. the nipple **12** is well below the level of the lower breast crease **16**. Contrary thereto, the breast **20** of
25 Fig. 2 is saggy and it is noticed that the nipple **22** is facing downward and extends below the infra-mammary fold **24**.

Reverting to Fig. 1, one can further notice several ribs **26**, pectoral muscle **28**, intercostals muscles **30** and the fat tissue **34**.

- 9 -

Turning now to Figs. 3A to 3H, there is illustrated a sequence of carrying out a breast lift according to a first embodiment of the present invention.

At a first step, after locally anesthesia of the breast **40**, two stab incisions **42** are formed at a bottom portion of the breast, with a surgical tool **44** (Fig. 3A). Then using an other tool **45**, a passage **46** is formed between the incisions and using that tool a cradling member **48** is yarned through the passage **46**, such that its slack ends **52** extend through the incisions **42** (Fig. 3B). As seen in Fig. 3B, the cradling member **48** comprises a central band-like portion **56** adapted for cradling and supporting the breast from below, and two yarns **52** extending at each side thereof. The band-like portion **56** as well as the yarns **52** may be made of organic material, e.g. tendons, or synthetic material e.g. Gortex™, etc.

Using tool **45**, two passages **58** are made (Fig. 3C), preferably extending from the incisions **42**. It is however noticed that the passages **58** may be formed before inserting the cradling member **48**. Through the passages **58** an anchoring tool **64** is applied (Fig. 3D), said tool **64** being pre-fitted with an anchoring screw **68** (preferably a self tapping screw) and a suspension member in the form of a cord **70** attached to the anchor screw **68**. By means of tool **64** the anchor screw **68** is screwed to rib **72**. The same procedure takes place through both passages **58**, with slack ends **76** of the suspension members extending from the incisions **42**.

Using a different tool designated **80** (such a tool is disclosed in more detail with reference to Figs. 7A to 7D), slack end **52** of the cradling member and the corresponding slack end **76** of the suspension member, are articulated, simultaneously at both sides of the breast (Fig. 3E). Preferably while the patient is in an upright position, tensioning begins using the tool **80**, by repeatedly pulling trigger **84**, until the breast elevates to a desired position. This action provides real time indication of the breast's new form and position, and even more so, the patient may take part in deciding to what extent to lift the breasts.

Once the breast **40** assumes the desired repositioning and form, a fixing clamp **88** is applied by tool **80** (Fig. 3G), and by further manipulating trigger **84** of

- 10 -

the tool **80**, the slack ends **52** of the cradling member and the corresponding slack ends **76** of the suspension member are trimmed (Fig. 3H).

The tool is then removed and shortly after the patient may be dismissed, with complete healing expected in a matter of days, essentially not leaving any
5 noticeable scars.

According to a different application, rather than using a tool, the slack end **52** of the cradling member and the corresponding slack end **76** of the suspension member may be manually tensioned and tied to one another, their ends being trimmed by conventional means, as known in the art of suturing .

10 Further attention is now directed to Figs. 4A to 4G, illustrating still another method for carrying out a breast lift according to the present invention.

First, two stab incisions **94** and **96** are made at a bottom portion of the breast **98**, and a corresponding passage **100** and **102** is formed extending towards a suitable posture tissue, rib **104** in the present example (Fig. 4A). A transverse
15 passage **109** is formed between the incisions **94** and **96**. Then a tool **108**, resembling a screwdriver, is introduced through the first passage **100**, said tool carrying at its fore end an anchor in the form of screw **110**, to which a suspension cord **112** is attached. The anchor is fixed to the rib **104** (Fig. 4B), and the tool **108** is removed leaving a long free end **114** of the suspension member, extending from
20 the incision **94** (Fig. 4C). Preferably, tool **108** is fitted with a screw holding member (not shown), to prevent the screw **110** from departing from the tip of the tool.

The free end **114** is then yarned back through the incision **94**, through the transverse passage **109** and out through the second incision **96**, leaving a looped
25 portion **120** extending from the first incision **94** (Fig. 4D). A second anchor **124** is then provided, which comprises an eye for slidably receiving the suspension cord **112**, and a clamp **128** is loosely mounted over two overlapping portions of the suspension cord (Fig. 4D). Using the same tool **108** (not shown in Fig. 4D), the second anchor **124** is introduced through the second passage **102** and is then

- 11 -

attached to the rib **104**, whilst the loose end **130** of the suspension cord extends from incision **96** (Fig. 4E).

The loose end **130** is then pulled in direction of arrow **134** (Fig. 4F), shrinking the looped portion **120** and tensioning the suspension cord until the breast
5 is deformed and lifted to a desired extent. At this point, a clamping tool **136** is introduced through incision **96**, to shrink the clamp **128**, so as to thereby fixate the tension of the suspension cord.

As mentioned in connection with the embodiment of Figs. 3, the tensioning step (Fig. 4F) is preferably carried out while the patient is in an upright position,
10 such that actual indication is available regarding the breast's new form and position, and even more so, the patient may take part in deciding to what extent to lift the breasts.

The loose end **130** is then trimmed, possibly by tool **136** (Fig. 4G) and the procedure is complete. Shortly after the patient may be dismissed, with complete
15 healing expected in a matter of days, essentially not leaving any noticeable scars.

Turning now to Figs. 5A and 5B, there is illustrated a breast **146** which in Fig. 5A is prior to breast lift and it is noticeable that nipple-areola complex **148** projection is lower than the infra-mammary fold **150**. However, in Fig. 5B the same breast, now designated **146'** has undergone a breast lift procedure in accordance
20 with the present invention and in this Figure the nipple-areola complex **148'** projection is higher than the infra-mammary fold **150'**. Further noted in Fig. 5A, a screw type anchor **154** is screw fixed into a rib **156**, with a suspension member in the form of cord **158** being attached thereto. A cradling member **160** extends through the fat tissue **162** of the breast, supports the breast from below, said
25 cradling member being tensioned and articulated to the suspension member by clamp **164**, thus lifting the breast and imparting it a firm and erect appearance.

In Figure 6, a female's thorax **170** is seen in which both the left and right breast **172** and **174** respectively, are supported by two sets of breast-lifting systems (**176** and **178** for the right breast; and **180** and **182** for the left breast), each
30 breast-lifting system being substantially similar to the systems disclosed herein

- 12 -

above. The difference resides in that each breast is supported by two sets and it is noticed that whilst in the left breast **172** each suspension member is anchored by two distinct anchors (**186; 188** for breast-lifting system **176**, and **190; 192** for breast-lifting system **178**), in the right breast **174** each suspension member is
5 anchored by only one, common anchor (**196** for breast-lifting system **180**, and **198** for breast-lifting system **182**).

Figs. **7A** to **7C** illustrate 3 breasts, each lifted by a breast lifting system according to the invention, each fitted with a different anchoring means for attaching the suspension member to a posture tissue. The breast **199** of Fig. **7A** the
10 anchor is a threaded anchor **200** screw-coupled into a rib **202**, with a suspension member **204** attached to the anchor. It is appreciated that the screw-type anchor may be a self-screwing thread type i.e. does not require preparatory boring in the bone tissue, there may be a bolt-type anchor, i.e. of the type which is inserted into a bore pre-drilled in the rib.

15 The breast **212** in Fig. **7B** is supported by a system in which a brace-type anchor **216** which is attached to two neighboring ribs **218** and **220**, e.g. by screws etc. in Fig. **7C** the breast **224** is supported by a system according to the invention in which the anchor is a suspending hook **228** bearing (clinging) from rib **230**. However, as mentioned herein above, the anchoring member may also be attached
20 to muscles e.g. by stitching or by a clasp, etc.

The cradling member **231** illustrated in the Figs. may be for example a tube-like member mounted on the suspension member **204**, for increasing the sectional area thereof.

According to another aspect of the invention, there is provided a surgical
25 tool useful in carrying out the method disclosed with reference to Figs. **3A** to **3H**. A tool **250** is illustrated in more detail with further reference to Figs. **8A** to **8D**.

The tool **250** has a general pistol-like shape having a gripping portion **252** fitted with a clamping trigger **256**, and a stem portion **258** having a fore end **260**. At least the fore end is sized for inserting through a stab-incision formed in a
30 breast, as illustrated for example in Figs. **3E** to **3G**. The fore end **260** is fitted with a

- 13 -

clamping unit receptacle **264** (best seen in Fig. 8D), accommodating an annular locking member **266** having a serrated inner bore **267** sized to receive therethrough an end of the cradling member **52** and a corresponding end of the suspension member **76** (see Fig. 3E). The stem portion **258** comprises a central bore **268** accommodating an elongate plug-stem **270** extending from the clamping unit receptacle **264** towards a rear end **272** of the stem portion, where it projects and is articulated to a lever **276** of the trigger **256**. A plug **278** is integrally connected by a tear zone **279** to a fore end of the plug-stem **270**. The plug **278** is serrated and sized for snappingly locking within the locking member **266**.

10 Coaxially received within the central bore **268** there is a trimmer **280** having a trimming end **282** at a fore end and a pusher **286** at its rear end, said pusher comprising two bores **287**. Two bores **288** and **290** extend through a portion of the stem portion **258**, fitted for receiving the end of the cradling member **52** and a corresponding end of the suspension member **76**.

15 In use, the end of the cradling member **52** and the suspension member **76** are threaded through the locking member **266**, yarned through the bores **288** and **290** respectively, then extending through the rear end **274** and through the bores **287** (Fig. 8A). This step is carried out at a step corresponding with the step illustrated in Fig. 3E. Then, the ends of the cradling member **52** and of the suspension member **76** are manually tensioned (Fig. 8A) to the desired position of the breast.

25 Upon squeezing trigger **256** (Fig. 8B) the plug-stem **270** is axially displaced in a rear direction, forcing the plug **278** to engage with the locking member **266**, clamping therebetween the cradling member **52** and of the suspension member **76**, at their tensioned position. Further squeezing of trigger **256** entails rupture of the tear zone **279** giving rise to a clamping unit **300** consisting of the plug **278** and the locking member **266**.

Then, pusher **286** is axially pressed in a forward direction as illustrated by arrow **294**, entailing the trimming end **282** to shear the cradling member **52** and of

- 14 -

the suspension member **76** (Fig. 8C). The tool may now be removed, discharging the clamping unit **300** and leaving it within the breast (not shown).

The tool **250** may be disposable or, according to a different embodiment may be made of a material suitable for reuse (after sterilization), where spare plugs
5 (and their associated plug-stems) are provided.

Whilst some embodiments have been described and illustrated with reference to some drawings, it will be appreciated that many changes may be made therein without departing from the general spirit and scope of the invention, *mutatis, mutandis*.

- 15 -

CLAIMS:

1. A system for breast lifting, wherein one or more anchors are fixed to a posture tissue, above a desired nipple level, with one or more suspending members suspended from the one or more anchors and extending through the breast for
5 cradling the breast from below.
2. A system according to claim 1, wherein the suspension member comprises a cradling portion for cradling the breast from below, said cradling portion being integral with or articulated to the suspension member, and having a greater width than the suspension member.
- 10 3. A system according to claim 2, wherein the cradling portion is a mesh-like portion.
4. A system according to claim 1, wherein the anchor is a bolt fixture or a threaded fixture fixed to a rib or a collar bone.
5. A system according to claim 4, wherein the anchor is a self tapping screw.
- 15 6. A system according to claim 1, wherein the anchor is a stitching to a muscle.
7. A system according to claim 1, wherein the anchor is a clasp for clasping a muscle.
8. A system according to claim 1, wherein the anchor is a suspending hook
20 bearing or clinging from a rib.
9. A system according to claim 1, wherein the suspension member and the cradling portion are made of organic or inorganic material.
10. A system according to claim 9, wherein the suspension member and the cradling portion are made of tendons.
- 25 11. A system according to claim 9, wherein the suspension member and the cradling portion are made of Gortex™.
12. A system according to claim 1, wherein the breast is lifted by two suspension members.

- 16 -

13. A system according to claim 1, wherein the one or more anchors and the one or more suspension members are deployable in a non-operable procedure.
14. A system according to claim 13, wherein the one or more anchors and the one or more suspension members are deployable through stab-incisions formed at a
5 bottom surface of the breast.
15. A system according to claim 1, being adjustable and removable at any time.
16. A system according to claim 1, wherein a single, continuous suspension member is yarned through the breast.
17. A system according to claim 17, wherein each end of the suspension
10 member is attached to a corresponding anchor.
18. A system according to claim 17, wherein both ends of the suspension member are attached to a single anchor.
19. A system according to claim 1, wherein respective ends of a cradling portion are fixedly attached to respective ends of two separate suspension
15 members.
20. A method for breast lifting, the method comprises the following steps:
- a) forming two stab-incisions at a bottom face of the breast;
 - b) forming two longitudinal passages extending from said stab-incisions towards a posture tissue;
 - 20 c) before or after step (b) forming a transverse passage through a bottom portion of the breast, extending between said stab-incisions;
 - d) threading a cradling member through the transverse passage;
 - e) introducing an anchor through each of the longitudinal passages, and attaching it to the posture tissue, with a suspension member attached to
25 each anchor member;
 - f) articulating ends of the cradling member to corresponding ends of the suspension members;
 - g) tensioning the one or both of the cradling member and the suspension members, to thereby lift the breast; and

- 17 -

h) fixating the relative position of the cradling member and the suspension members.

21. A method according to claim 20, wherein after step (h) excessive ends of the suspension members and of the cradling member are trimmed.

5 22. A method according to claim 20, wherein step (g) is carried out by a clamp, clampingly arresting the cradling member and respective ends of the suspension members.

23. A method according to claim 20, wherein step (h) is carried out while in an upright position.

10 24. A method for breast lifting, the method comprises the following steps:

a) forming two stab-incisions at a bottom face of the breast;

b) forming two longitudinal passages extending from said stab-incisions towards a posture tissue;

15 c) before or after step (b) forming a transverse passage through a bottom portion of the breast, extending between said stab-incisions;

d) introducing a first anchor through a first stab-incision and a corresponding longitudinal passages, and attaching it to the posture tissue, with a first end of a suspension member attached to the anchor member;

20 e) extracting the suspension member through the first stab-incision;

f) yarning a second end of the suspension member through the transverse passage, leaving a looped portion extending from the first stab-incision;

25 g) introducing a second anchor through the second stab-incision and the corresponding longitudinal passages, and attaching it to the posture tissue, with a the suspension member being slidably attached to the second anchor member;

h) tensioning the suspension member so as to lift the breast;

i) fixating the relative position of the suspension member.

30 25. A method according to claim 23, wherein step (h) is carried out while in an upright position.

- 18 -

26. A method according to claim 23, wherein after step (i) excessive end of the suspension member is trimmed.
27. A method according to any one of claims 20 and 23, wherein the anchor is according to any one of claims 4 to 7.
- 5 28. A method according to any one of claims 20 and 23, wherein the posture tissue is a chest bone or muscle.
29. A method according to any one of claims 20 and 23, wherein the suspension member comprises a cradling portion for cradling the breast from below, said cradling portion being integral with or articulated to the suspension
10 member, and having a greater width than the suspension member.
30. A method according to any one of claims 20 and 23, wherein the cradling portion is a mesh-like portion.
31. A method according to any one of claims 20 and 23, wherein the suspension member and the cradling portion are made of organic or inorganic
15 material.
32. A method according to any one of claims 20 and 23, wherein the suspension member and the cradling portion are made of tendons.
33. A method according to any one of claims 20 and 23, wherein the suspension member and the cradling portion are made of Gortex™.
- 20 34. A method according to any one of claims 20 and 23, wherein all the respective steps are repeated at adjacent locations within the breast, so as to support the breast by two cradling members.
35. A surgical tool for use in a breast-lift procedure, for tensioning and clamping cord-like cradling members and corresponding suspension members, said
25 tool comprising a housing fitted at a fore end with a cord receiving opening for receiving two or more cords, a clamping mechanism for clampingly articulating the at least two cords, and a cord trimming mechanism for trimming the cords adjacent the clamp.

– 19 –

36. A surgical tool according to claim 35, wherein tensioning of the cradling member and the corresponding suspension member is facilitated by pulling their ends.

37. A surgical tool according to claim 35, wherein tensioning of the cradling
5 member and the corresponding suspension member is facilitated by pulling a tensioning trigger which frictionally grasps the cradling member and the corresponding suspension member.

38. A surgical tool according to claim 35, wherein the cord trimming mechanism comprises a sheering member activated from a rear end of the tool.

10 39. A surgical tool according to claim 35, wherein the cord trimming mechanism comprises a sheering member activated by a trigger mechanism.

40. A surgical tool according to claim 35, wherein the clamping mechanism comprises a plug member and a locking member, whereby the cradling member and the corresponding suspension member pass through the locking member and
15 clamping occurs by locking engagement of the plug member within the locking member.

41. A surgical tool according to claim 40, wherein one or both of the plug member and the locking member are serrated to improve locking engagement.

42. A surgical tool according to claim 40, wherein one of the locking member
20 and the plug member is stationary retained within the tool and the other of said locking member and the plug member is axially displaced into locking engagement therewith, by means of an activating trigger.

43. A surgical tool according to claim 35, being a disposable tool.

44. A surgical tool for carrying out a breast-lift procedure according to any one
25 of claims 20 to 34, said tool adapted for tensioning and clamping a cord-like cradling member and a corresponding suspension member; said tool comprising a housing fitted at a fore end with a cord receiving opening for receiving two or more cords, a clamp deploying mechanism for clampingly articulating the at least two cords, and a cord trimming mechanism for trimming the cords adjacent the clamp.

- 20 -

45. A kit for carrying out a breast-lift procedure, the kit comprising at least one set of suspension members, anchoring means for anchoring a suspension member to a posture tissue, and means for tensioning and fixating the suspension member.

46. A kit according to claim 45, further comprising one or more
5 breast-cradling/padding members

47. A kit according to claim 45, further comprising one or more surgical tools to facilitate tensioning, clamping and trimming of a suspension member and a cradling member.

48. A kit according to claim 45, further comprising a tool for fixing an anchor
10 to a posture tissue.

1/9

FIG. 1

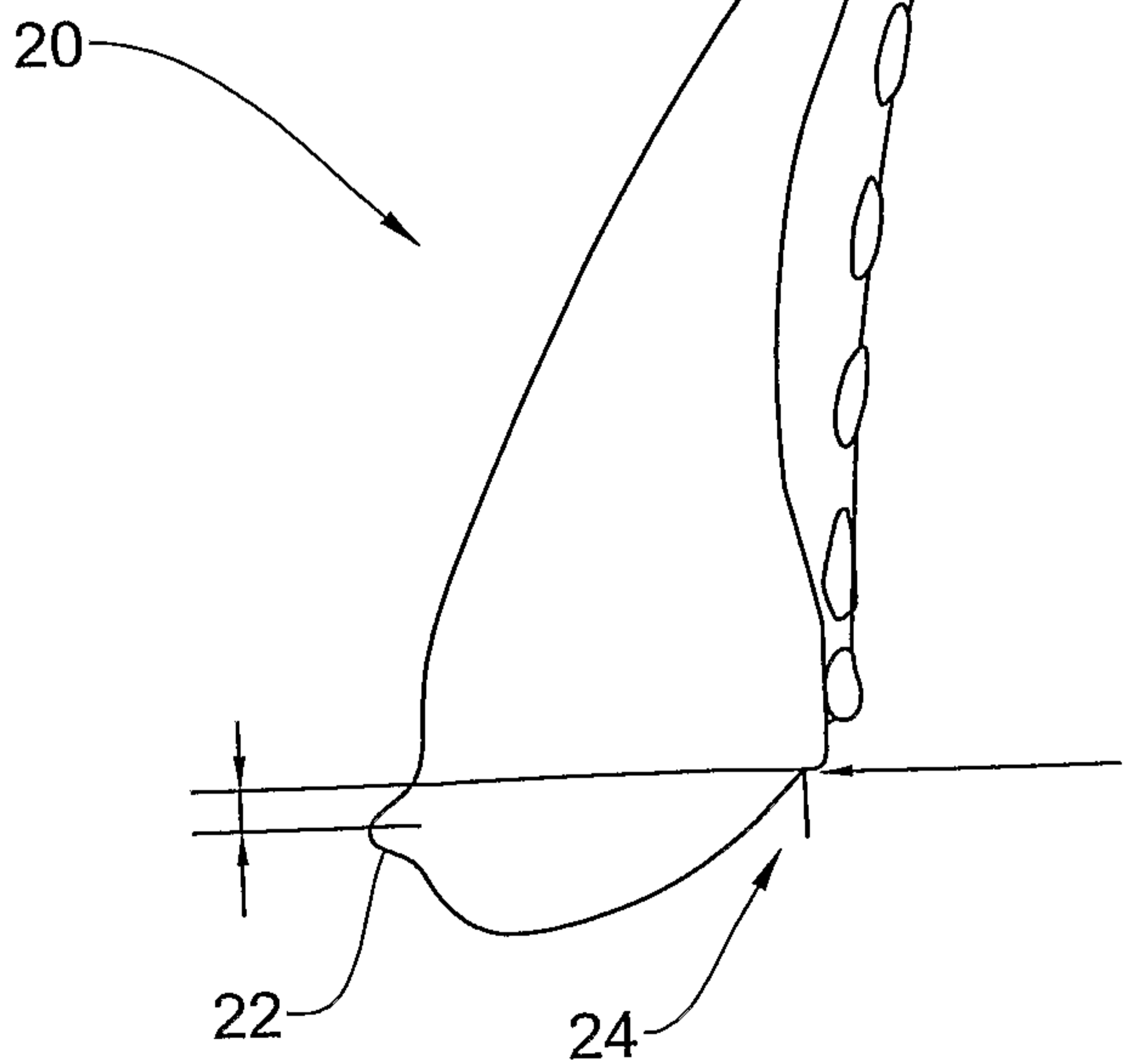
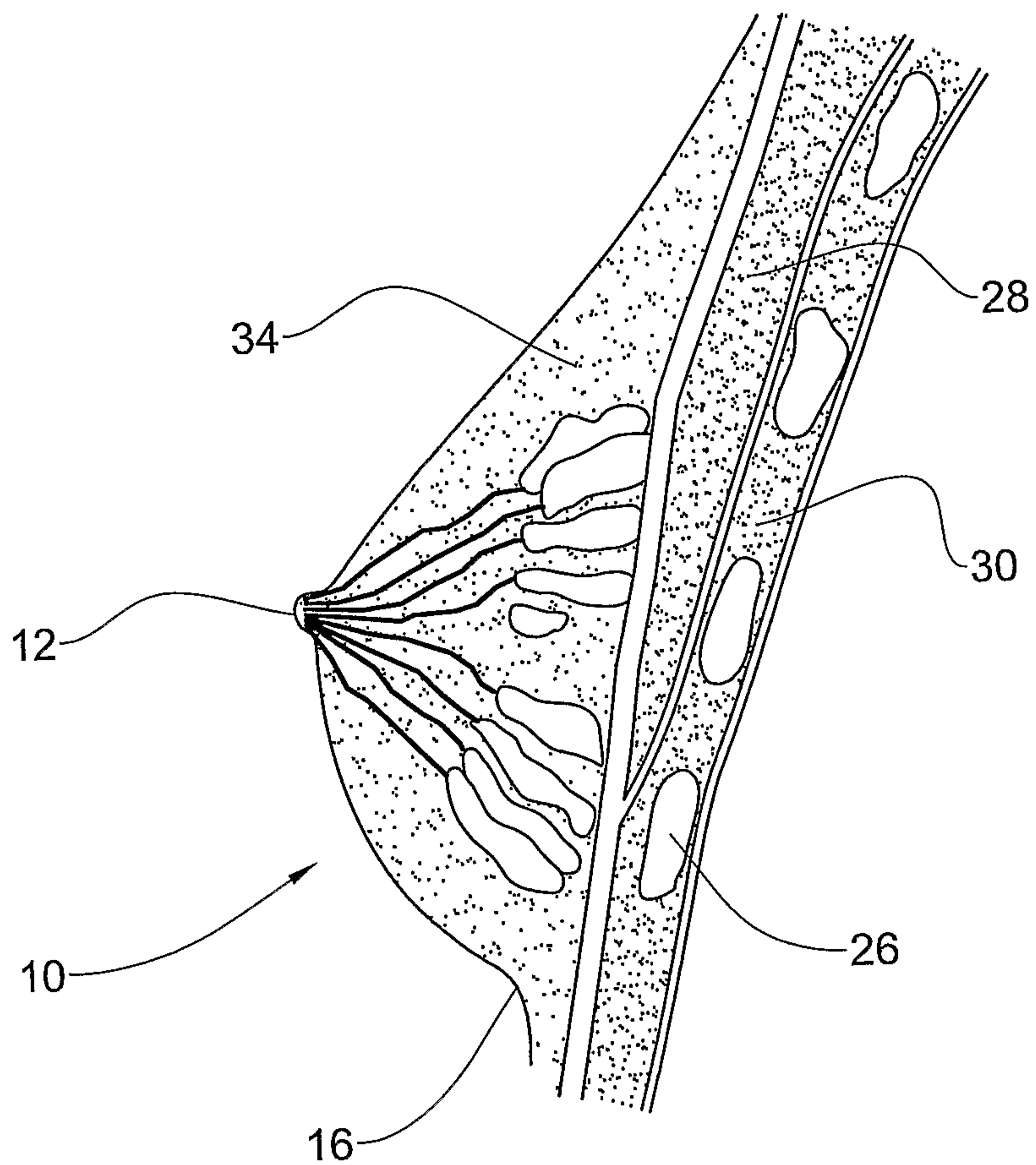

FIG. 2

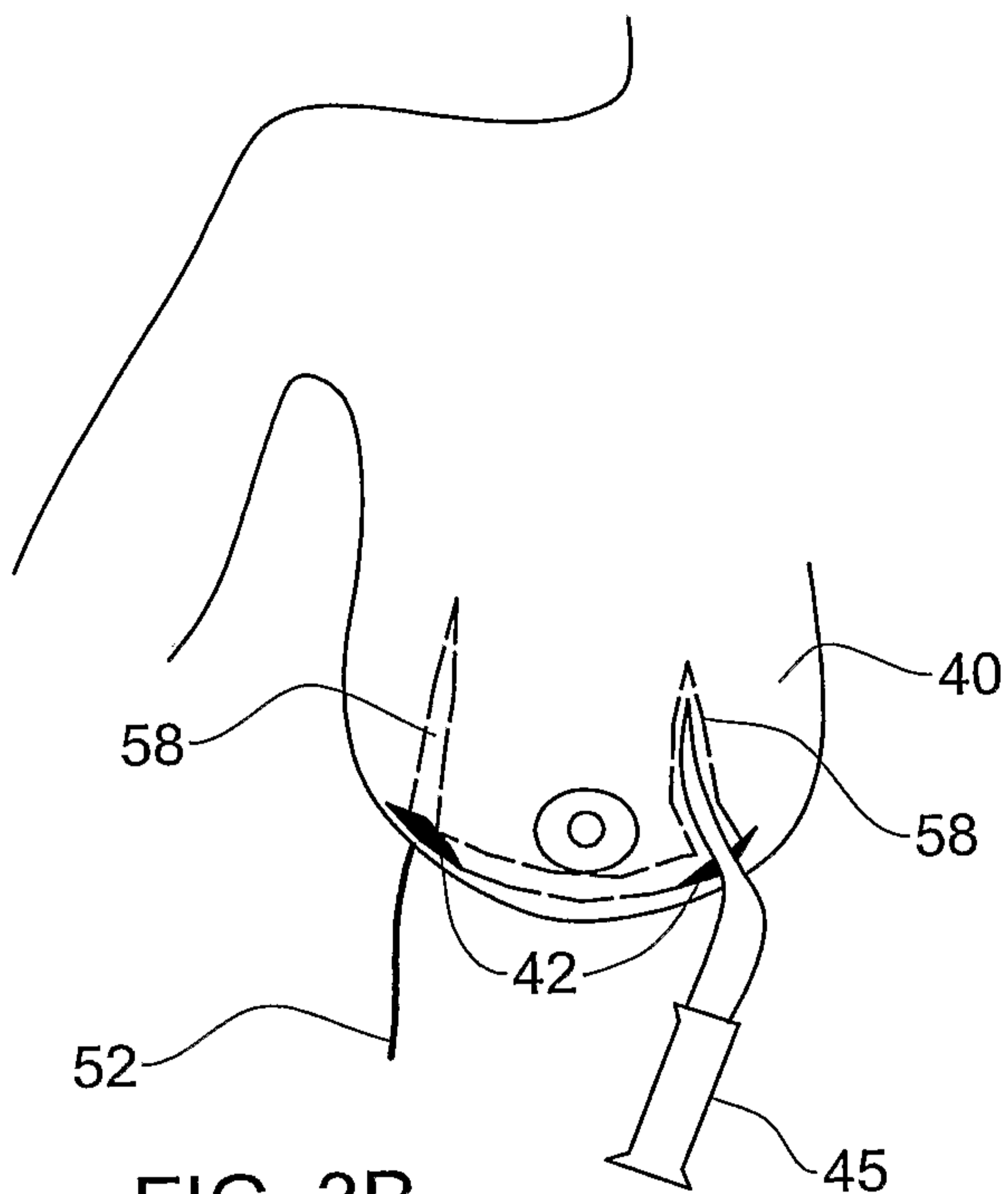

FIG. 3B

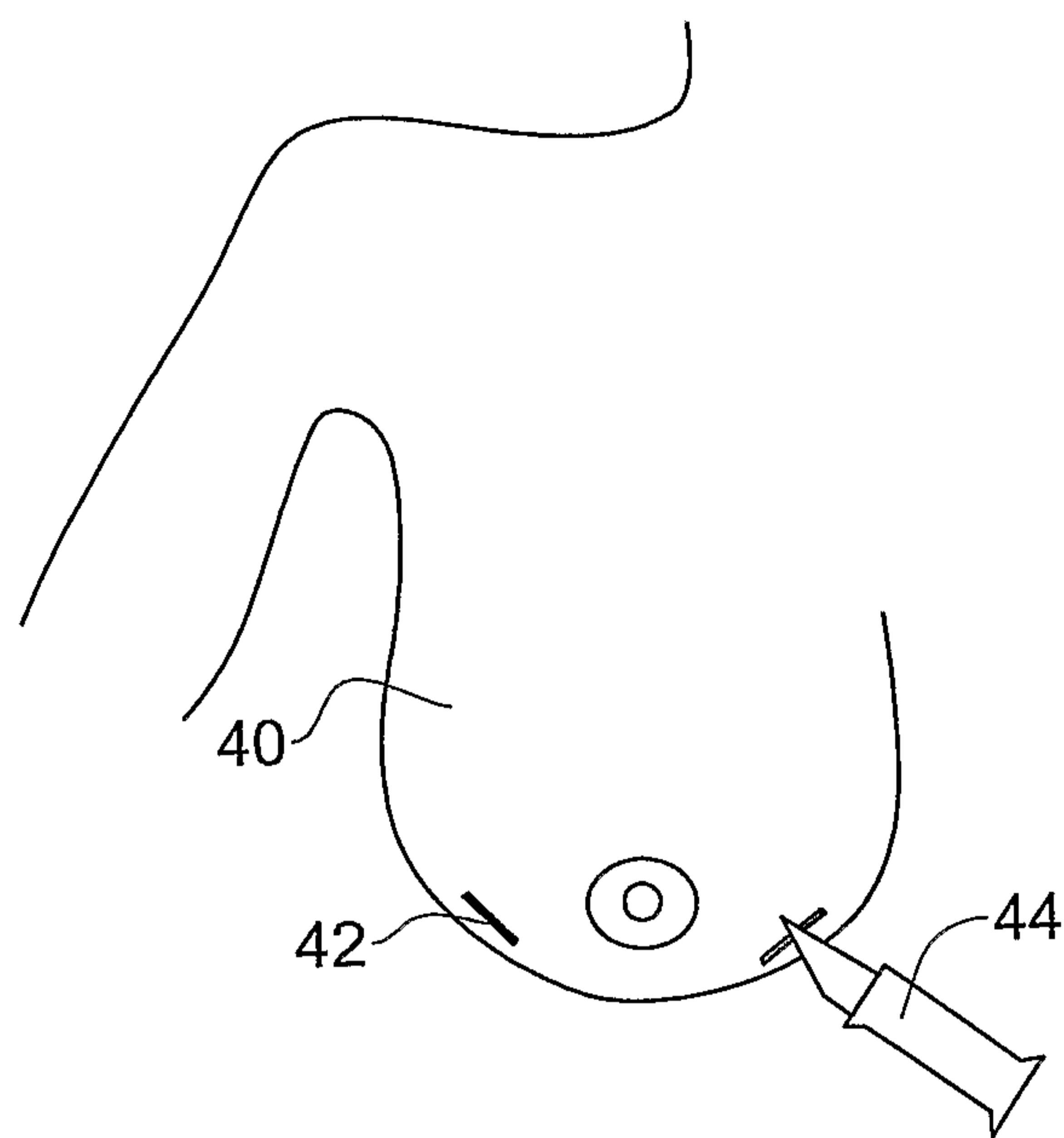

FIG. 3A

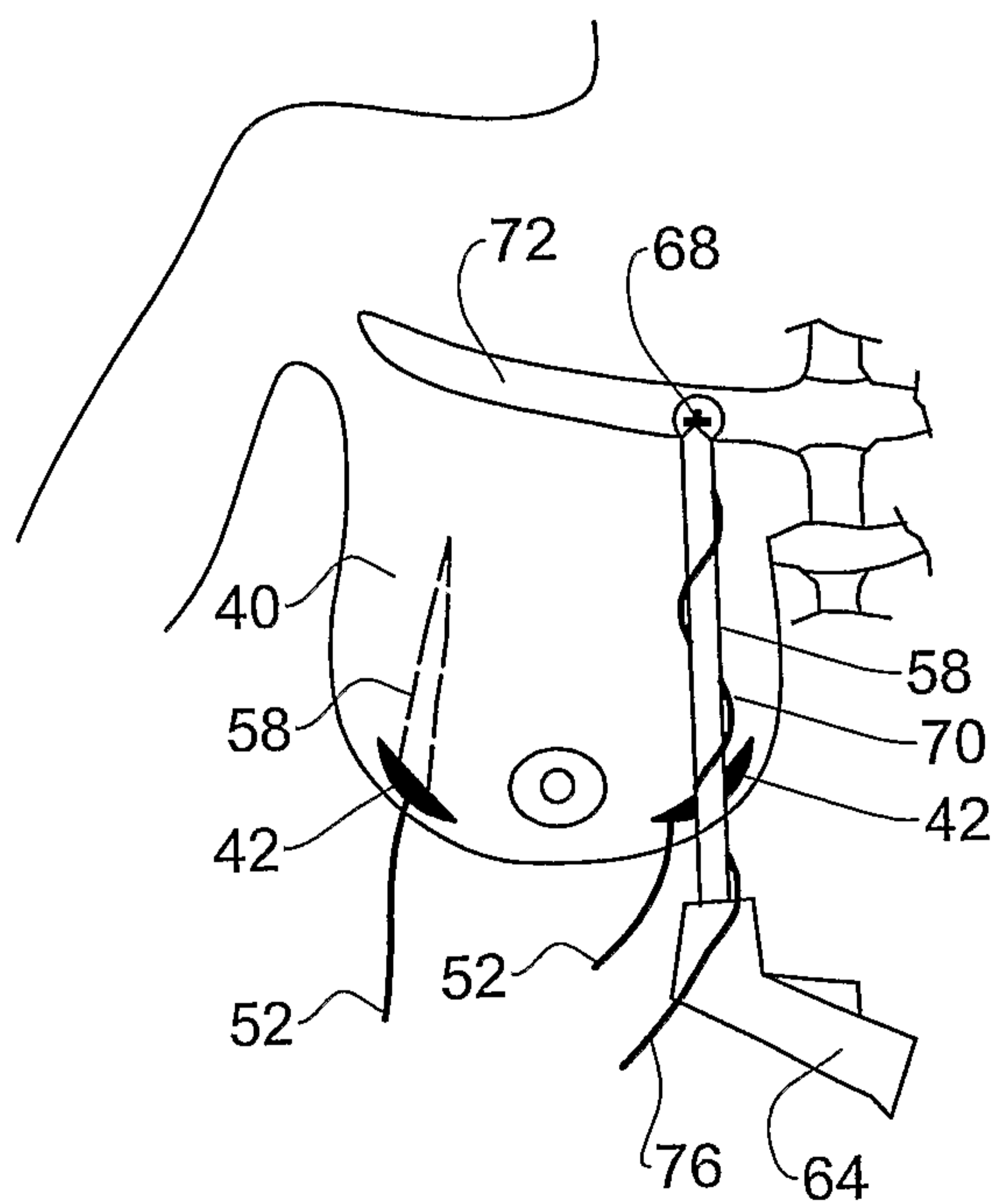

FIG. 3D

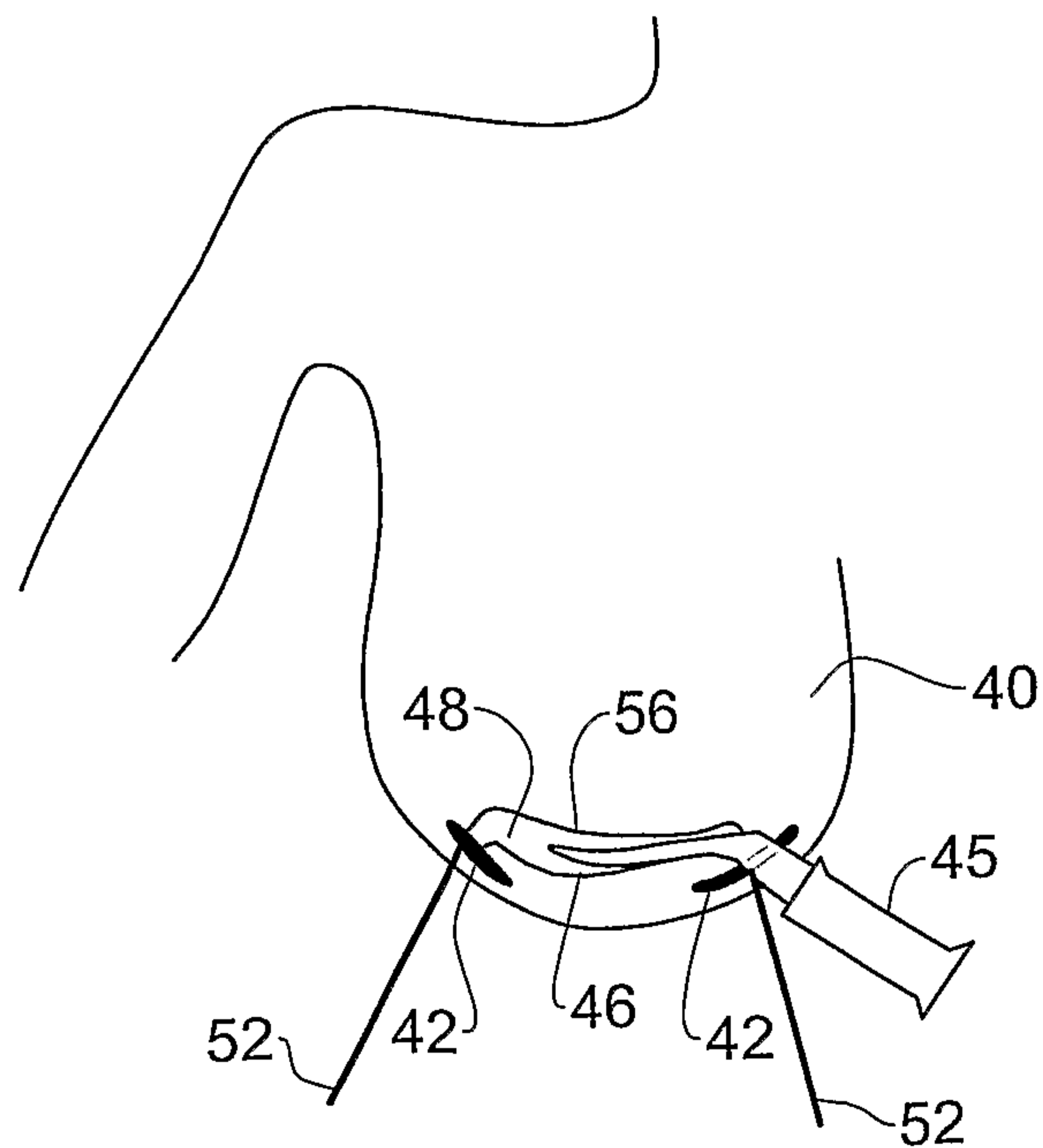

FIG. 3C

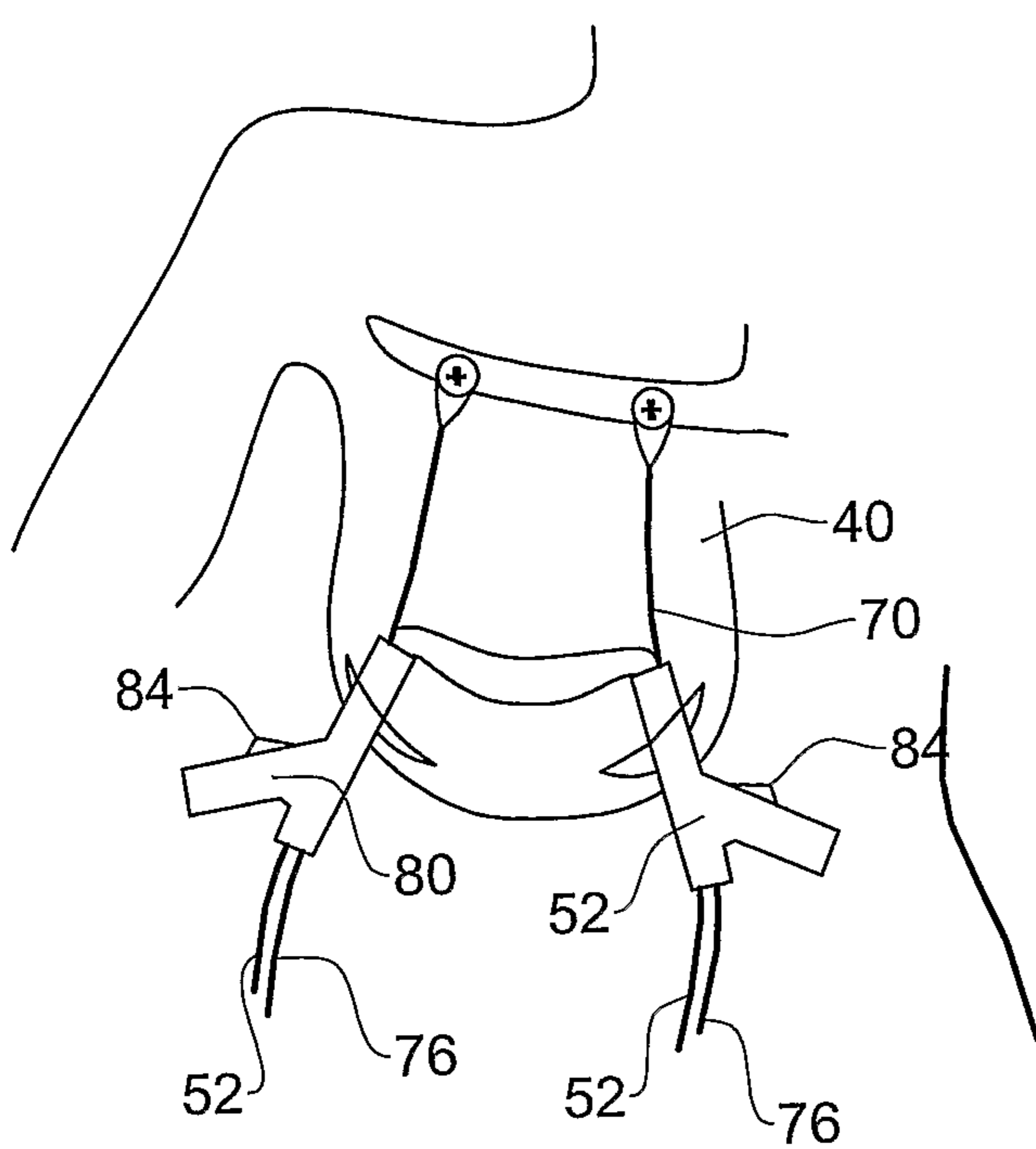

FIG. 3F

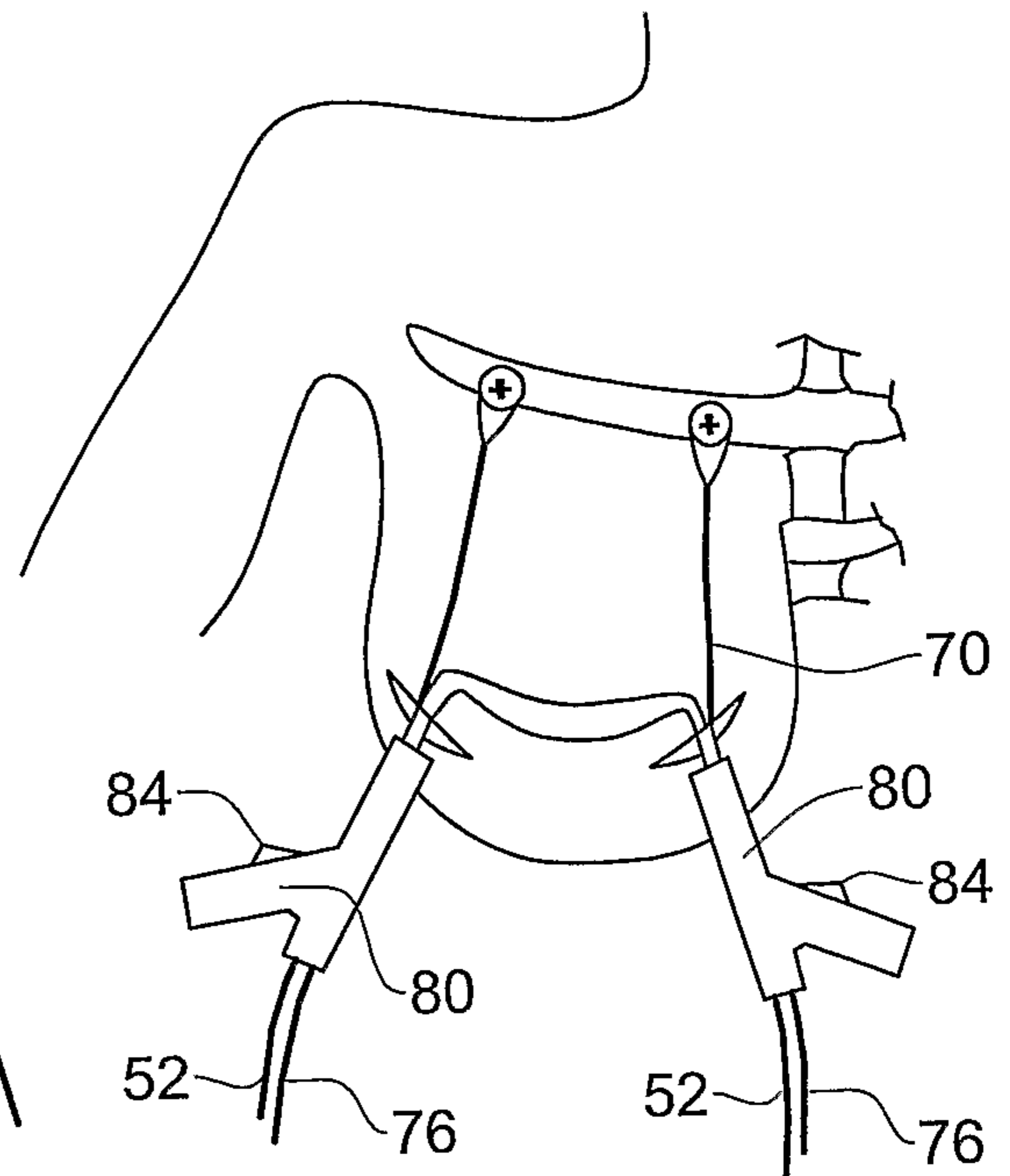

FIG. 3E

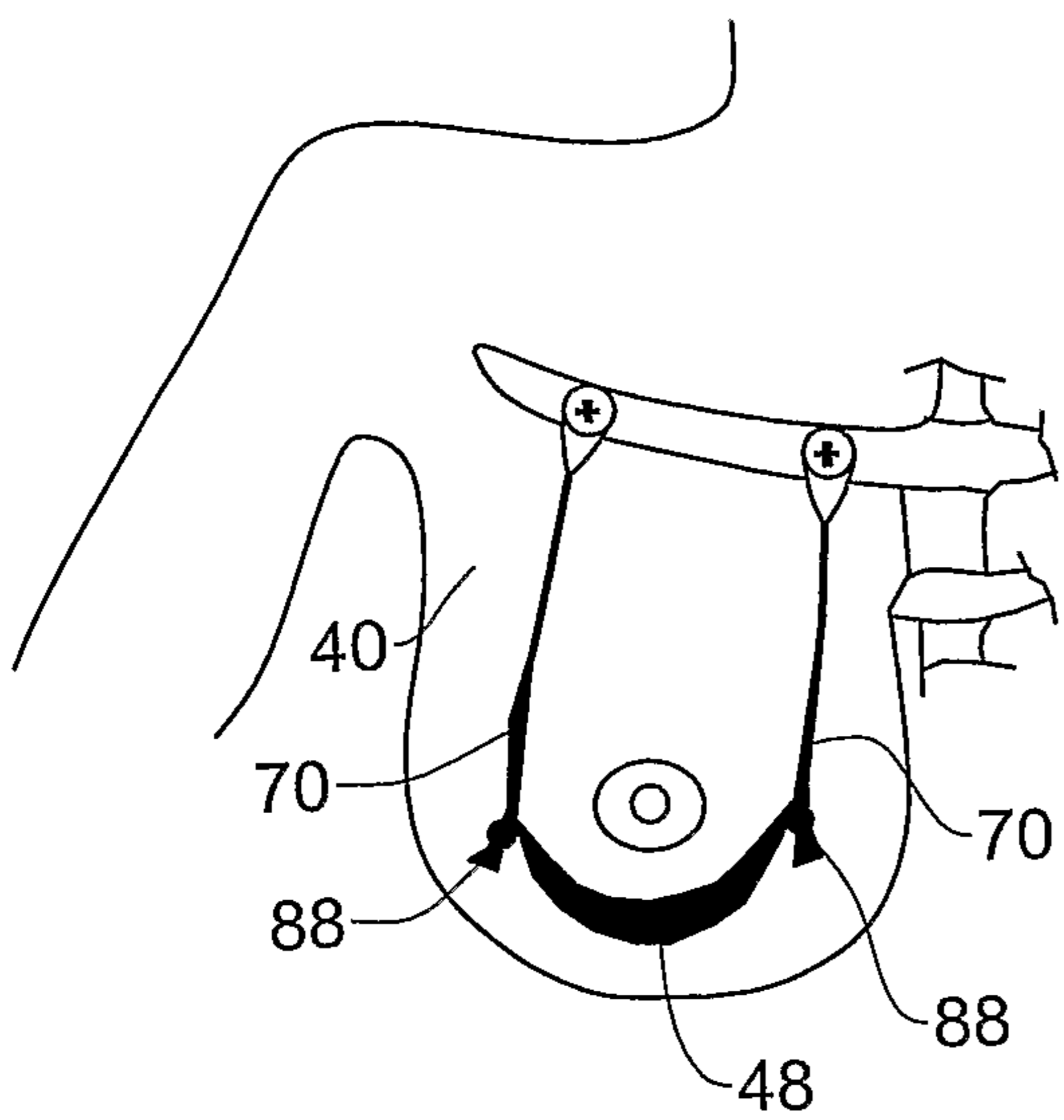

FIG. 3H

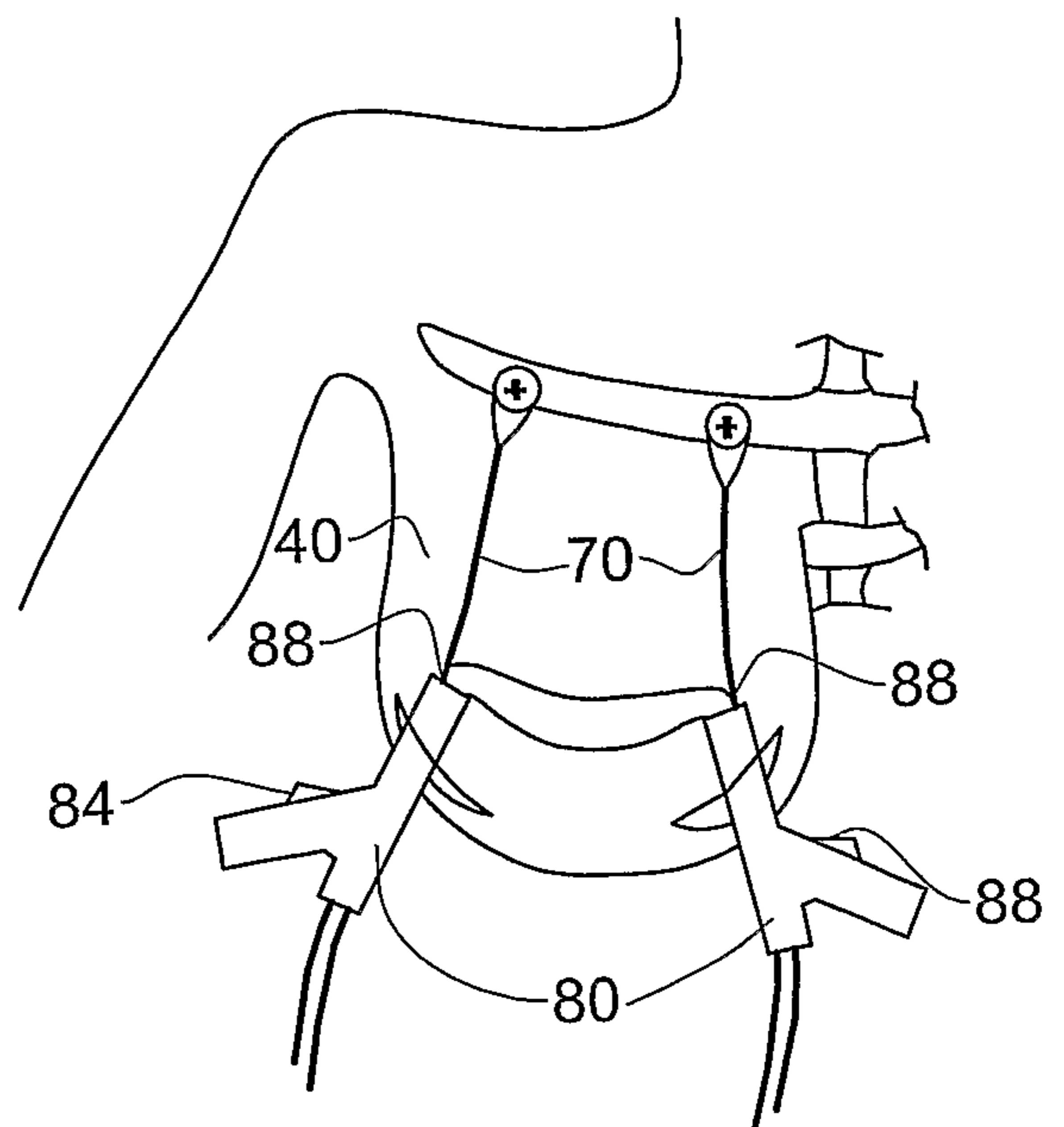

FIG. 3G

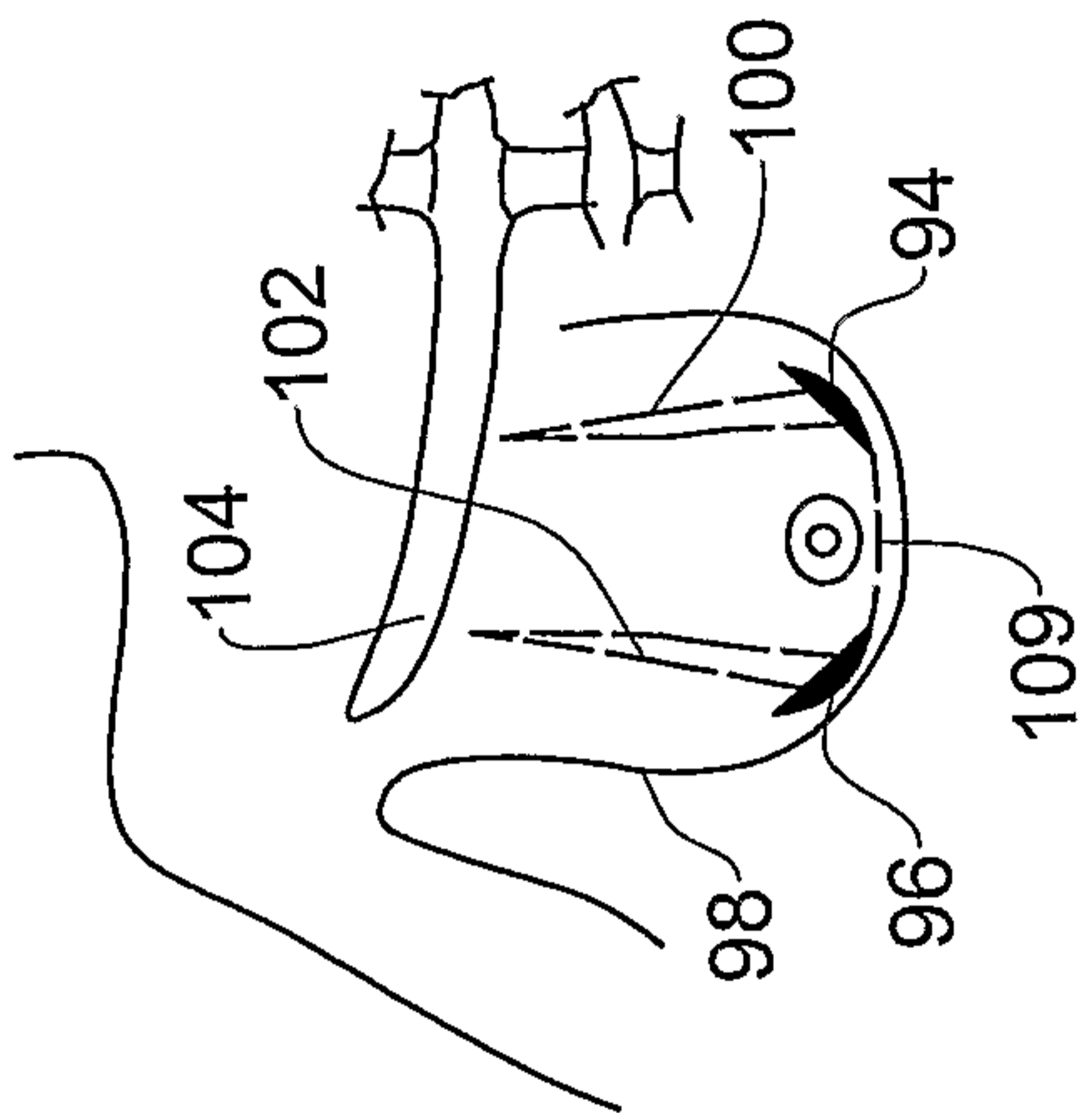

FIG. 4A

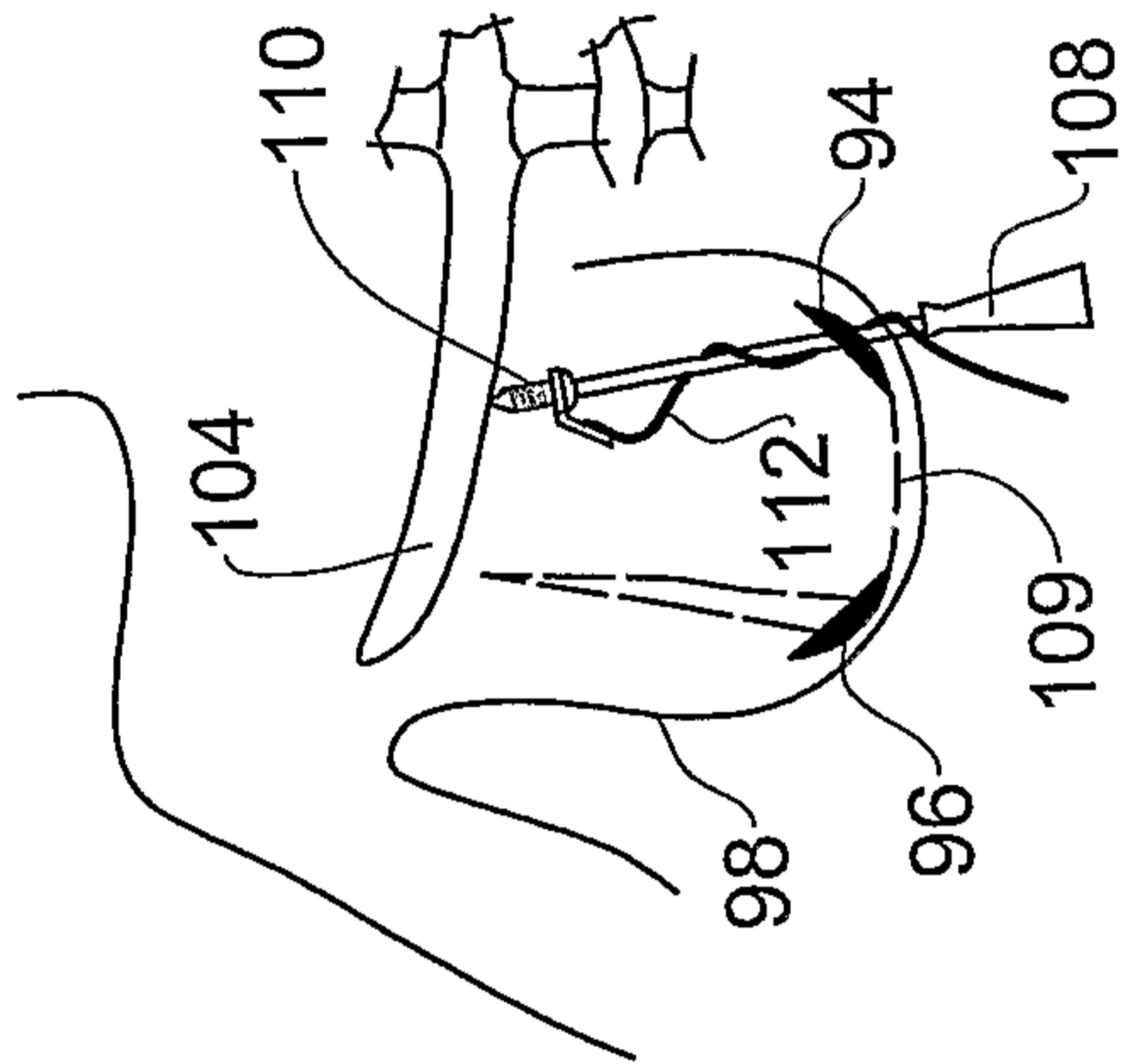

FIG. 4B

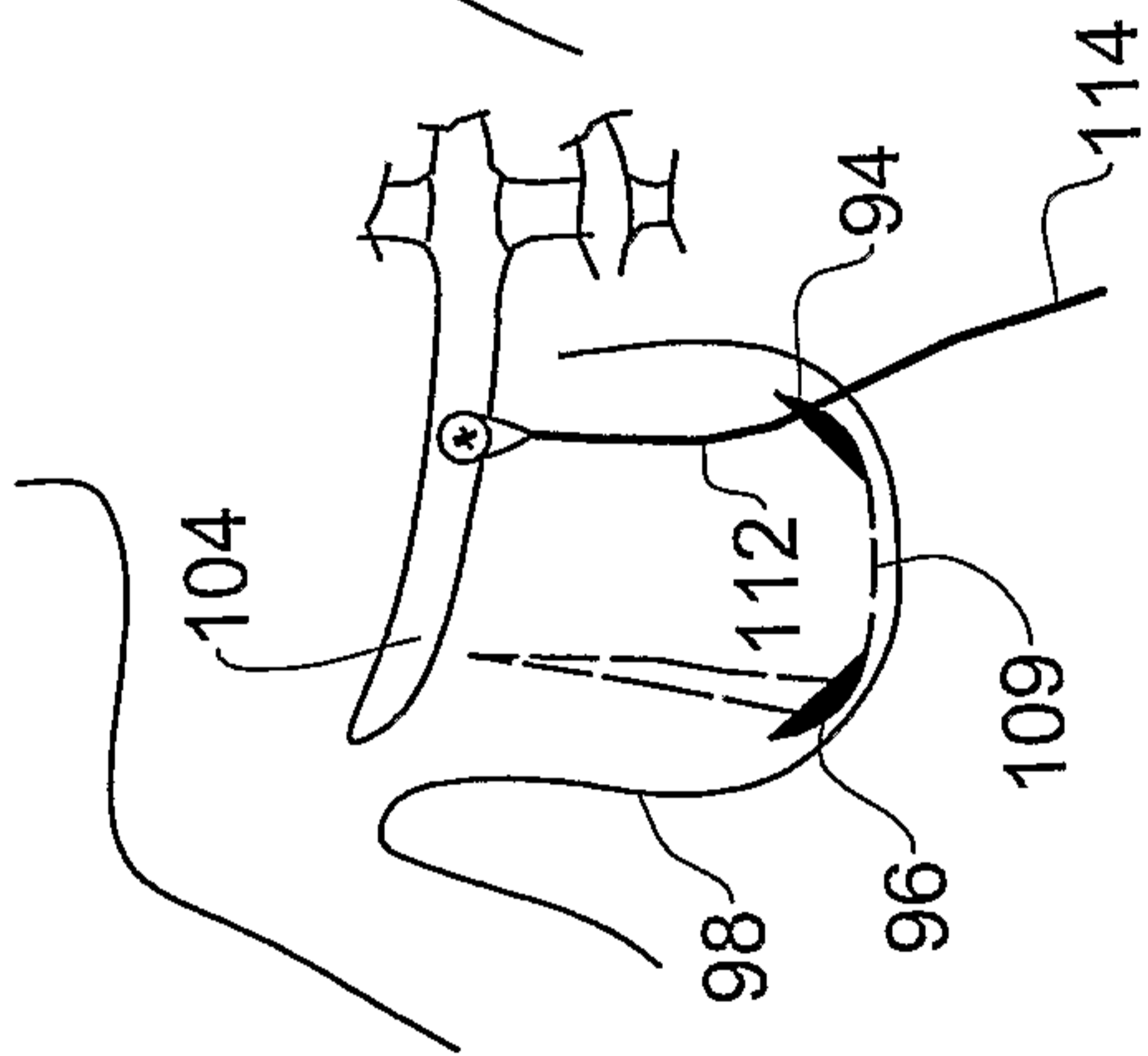

FIG. 4C

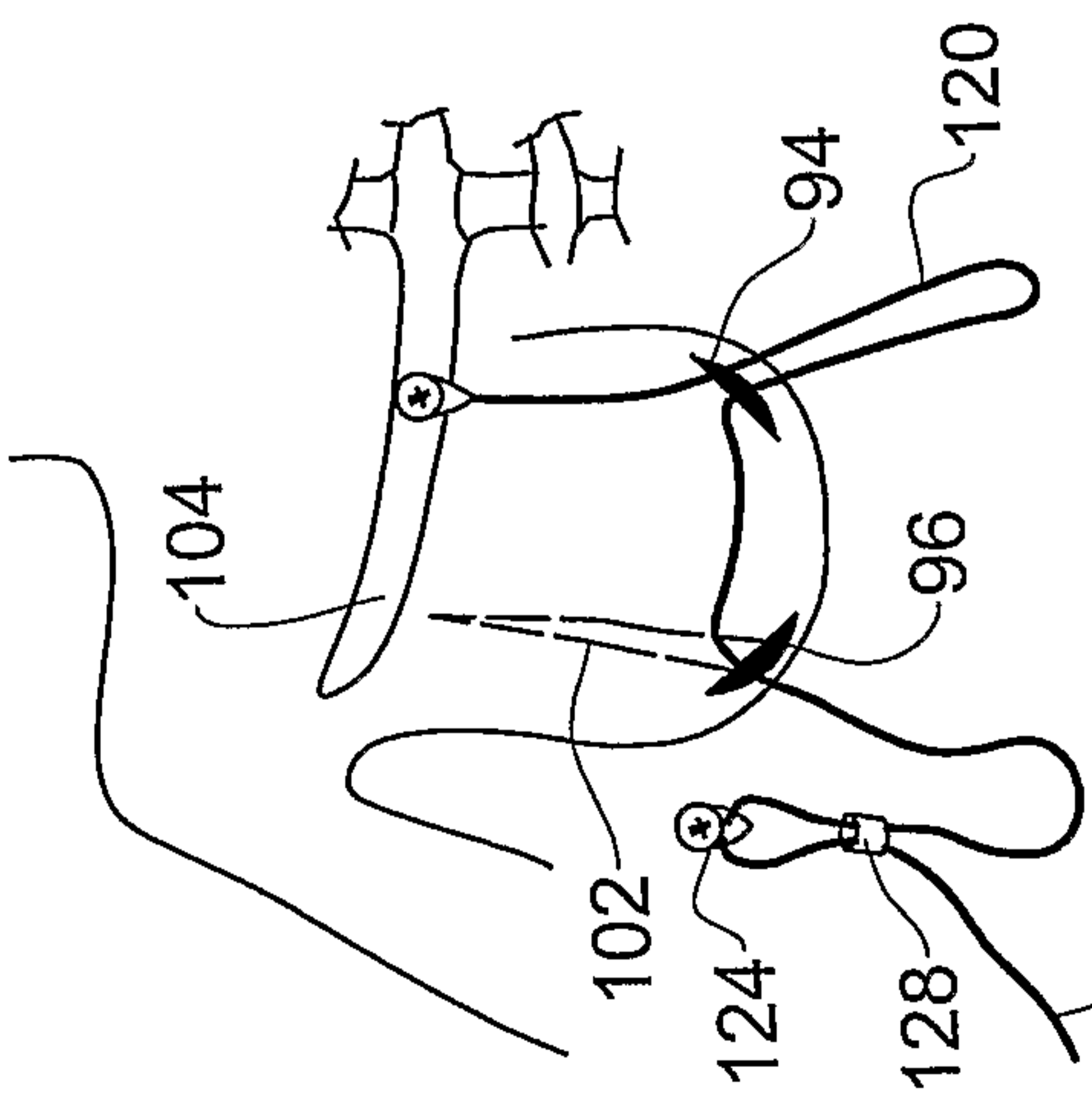

FIG. 4D

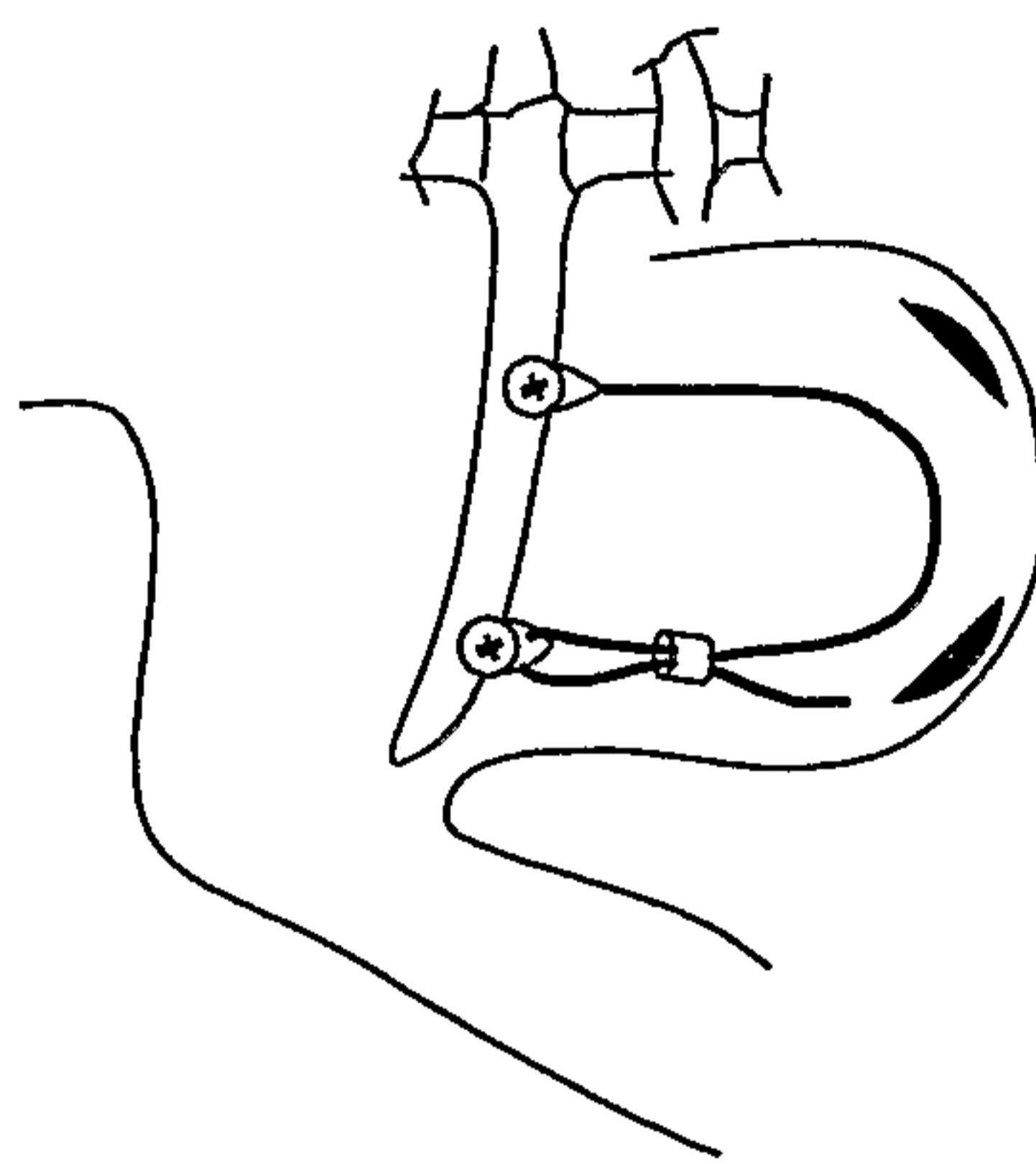

FIG. 4G

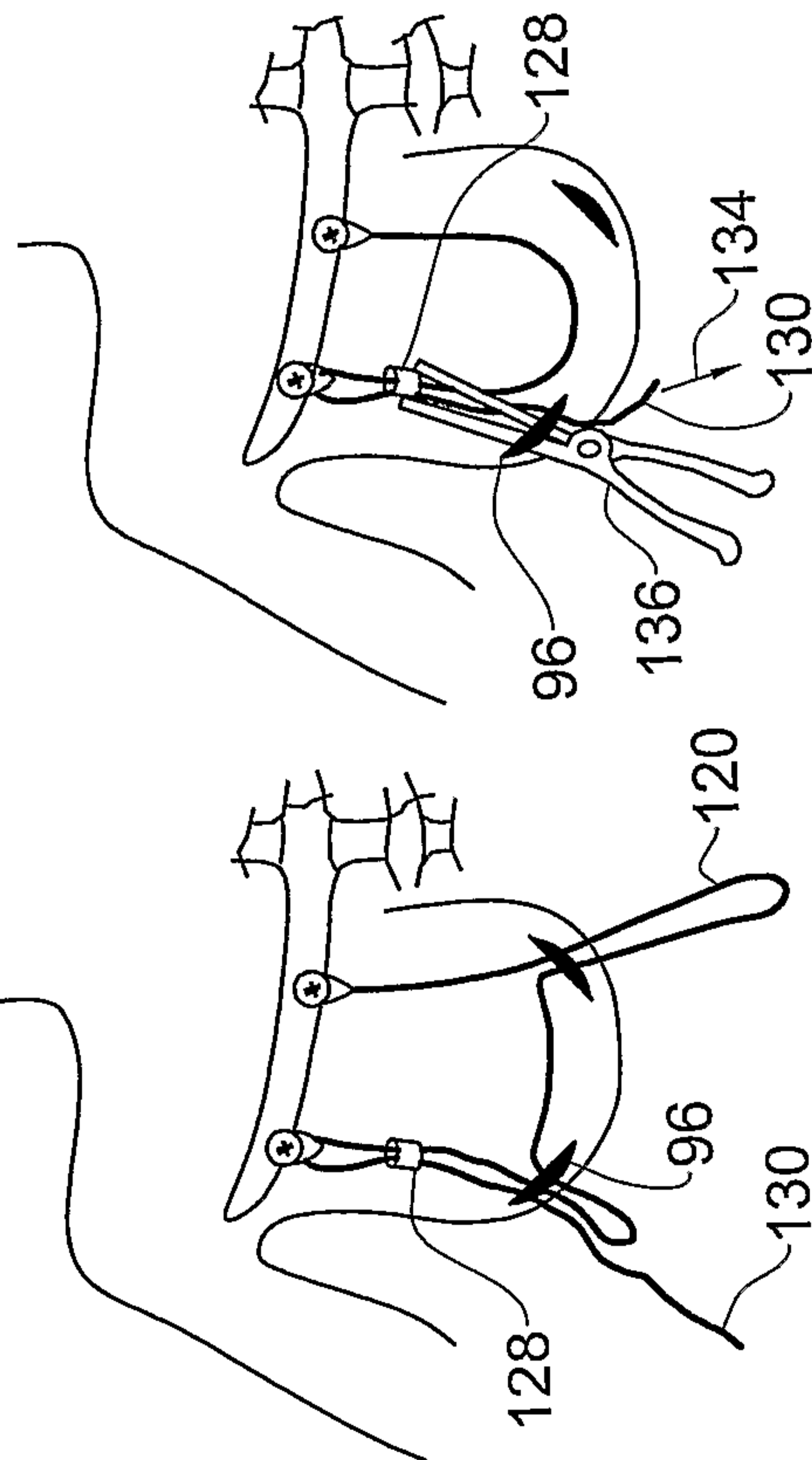

FIG. 4E

FIG. 4F

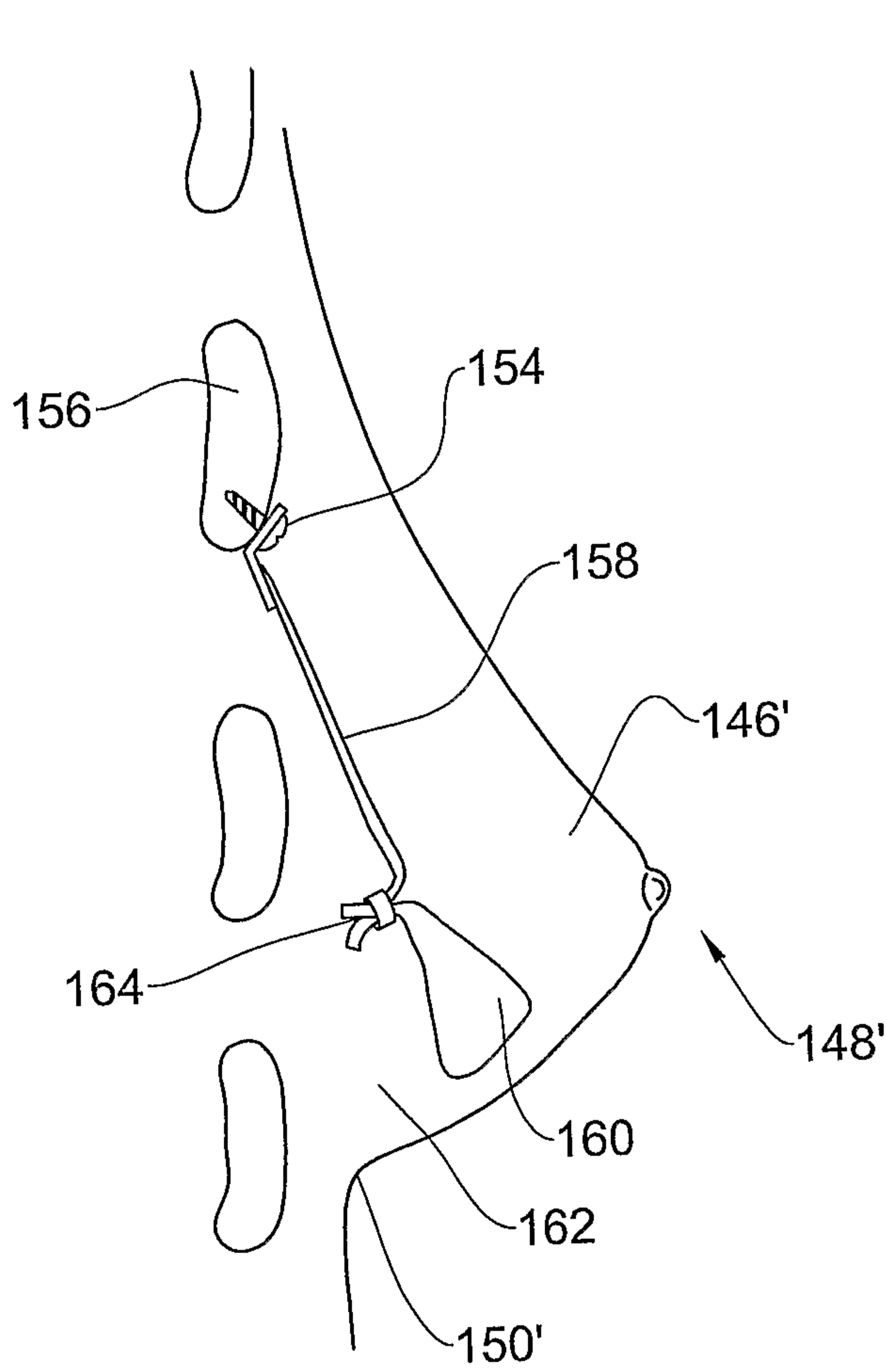

FIG. 5B

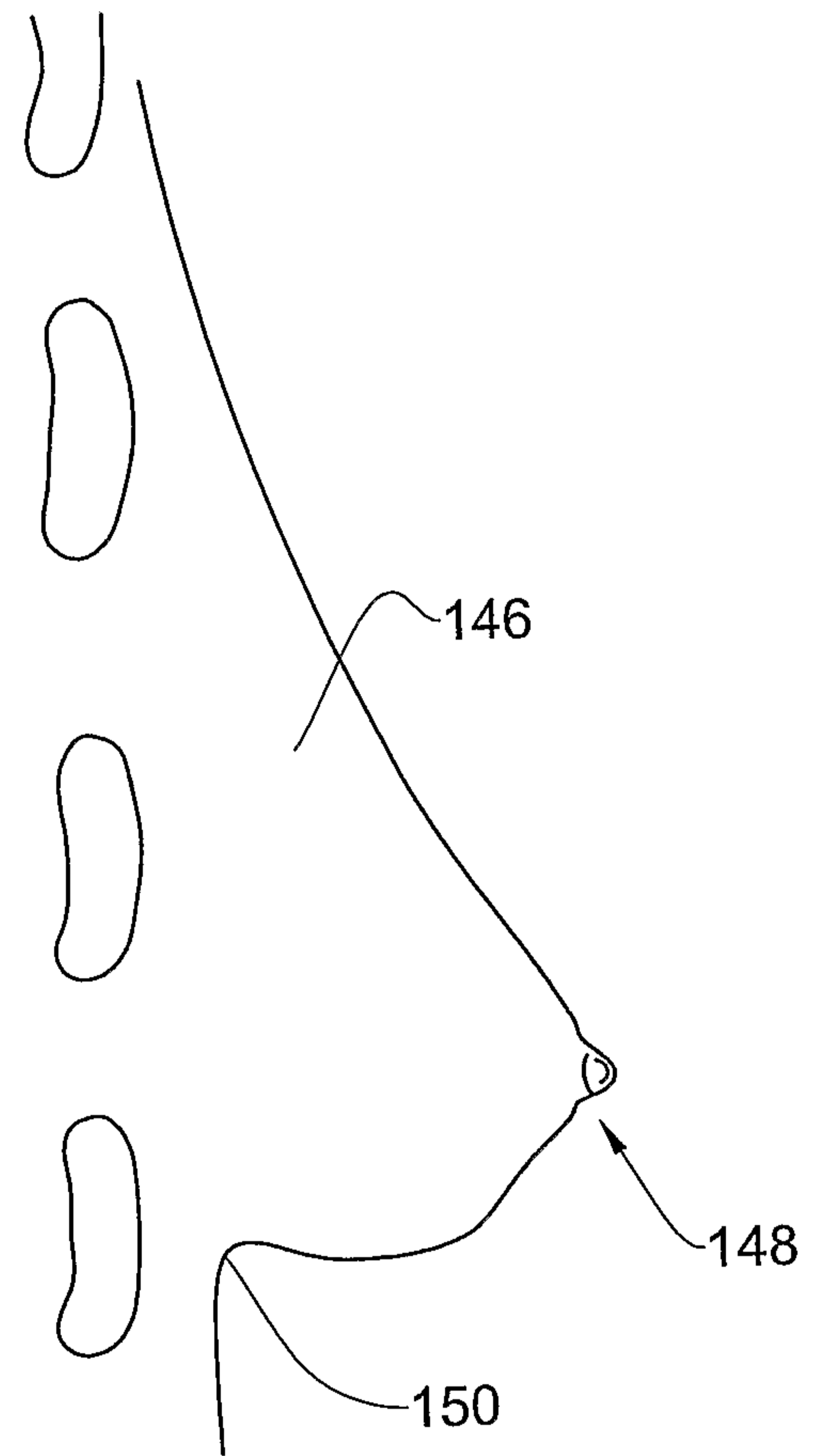

FIG. 5A

6/9

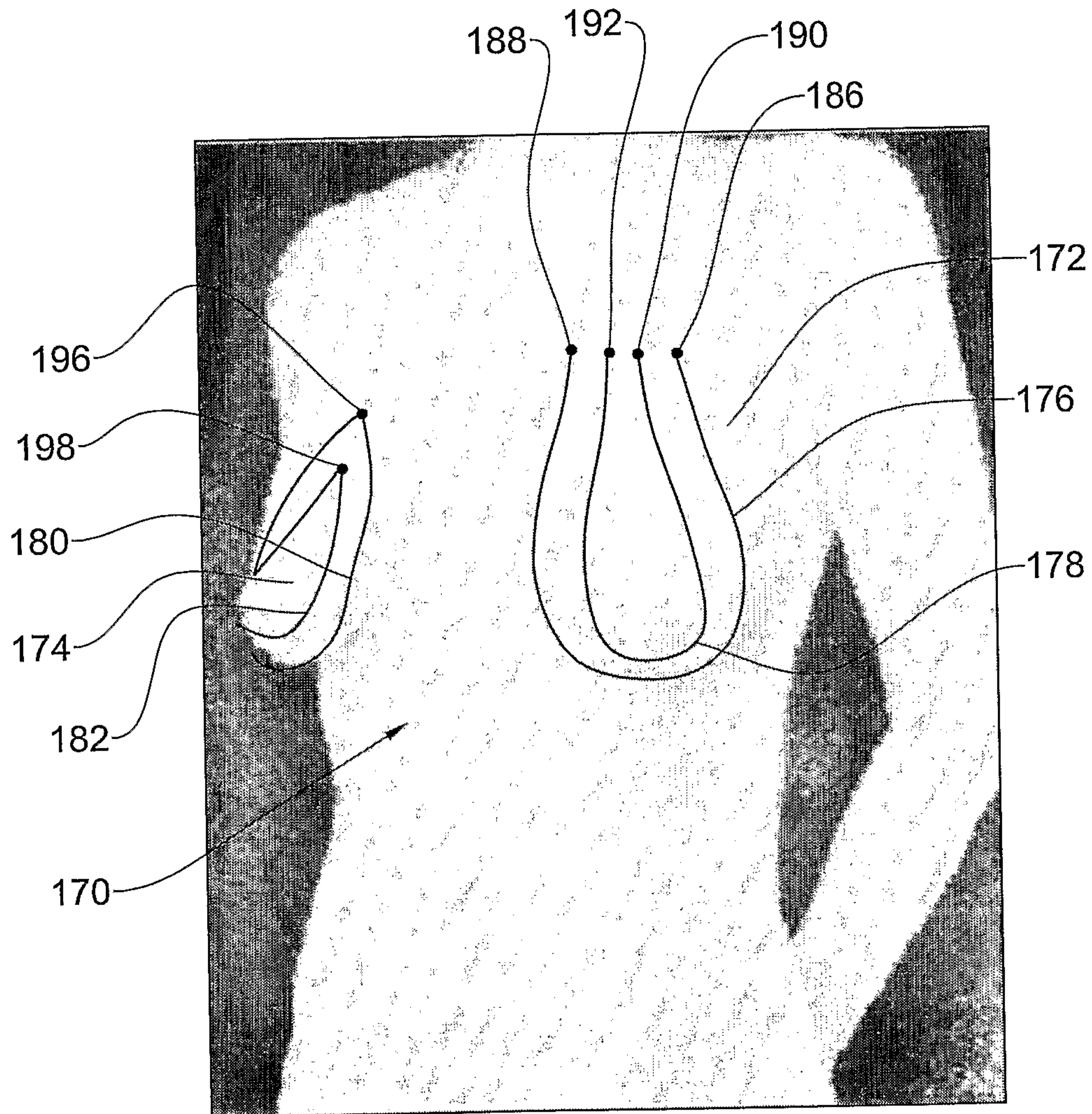

FIG. 6

7/9

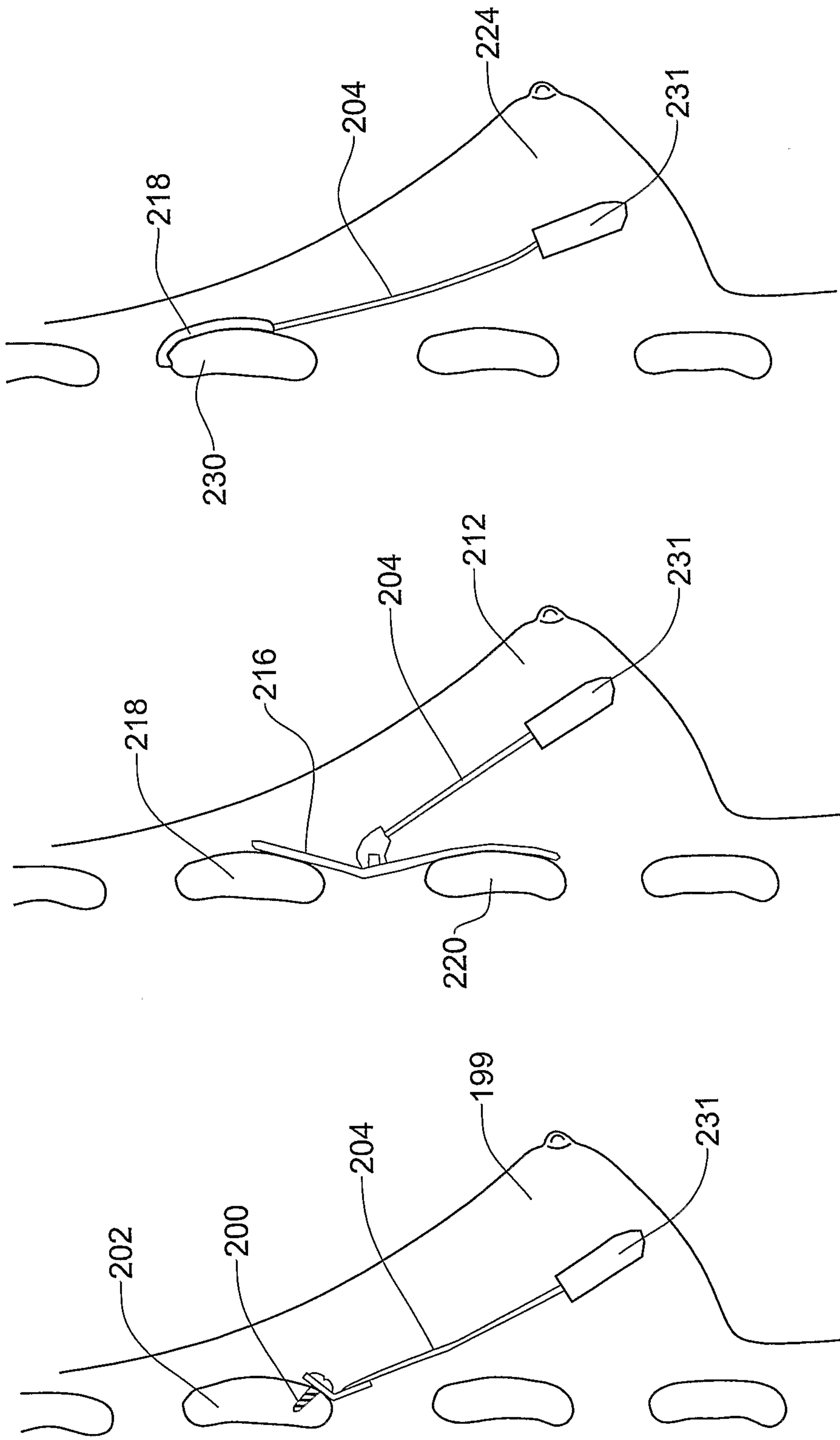
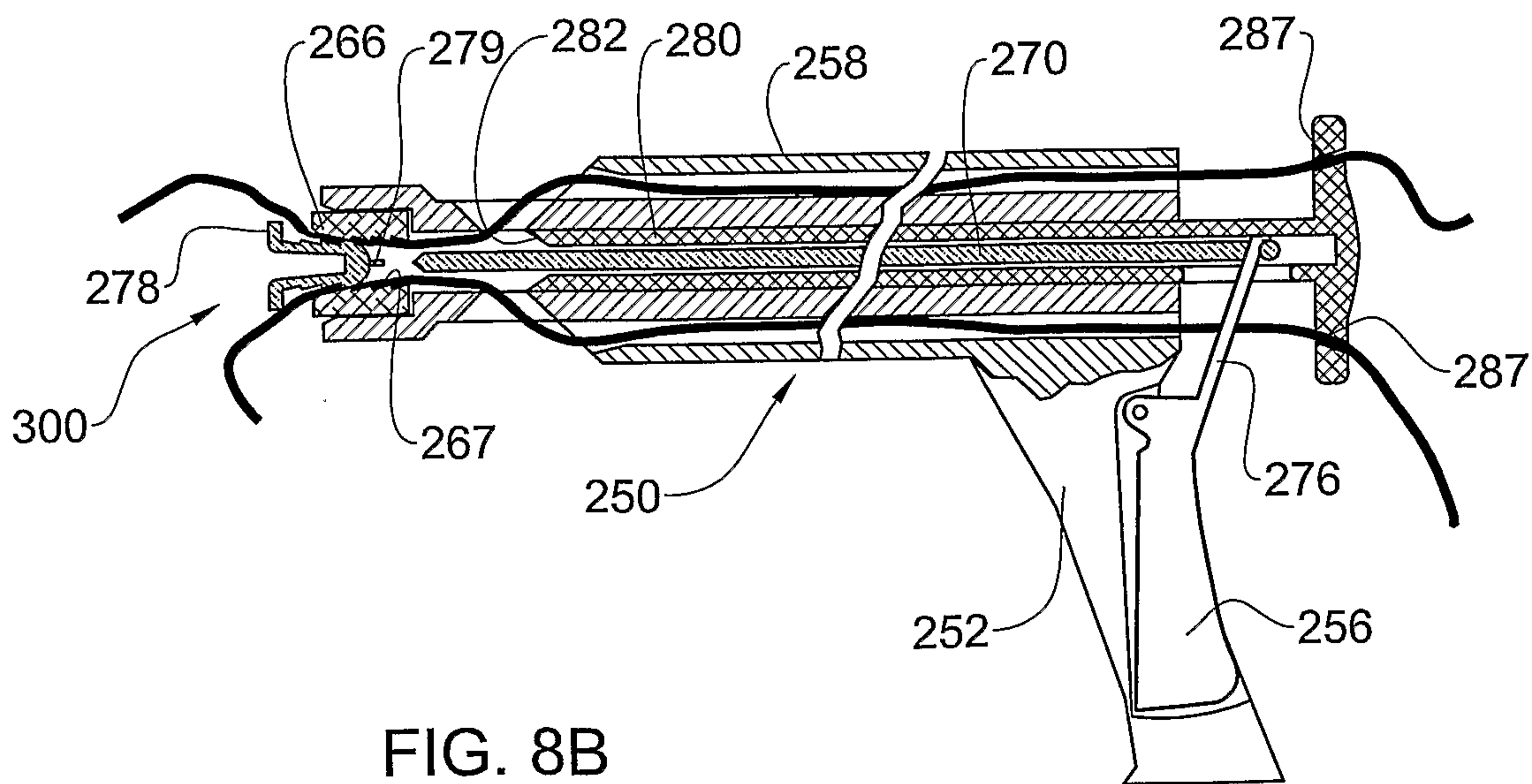
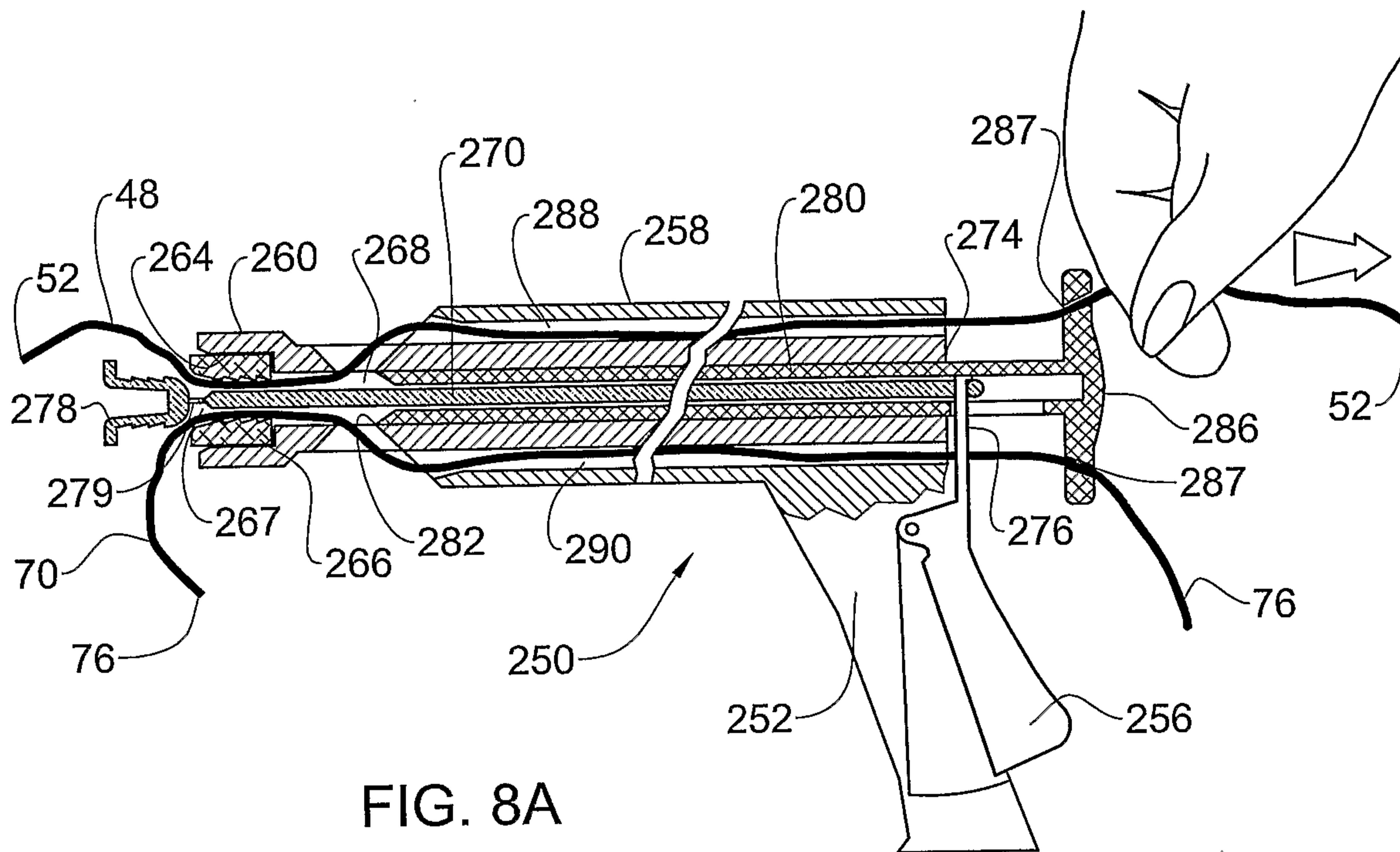

FIG. 7C

FIG. 7B

FIG. 7A



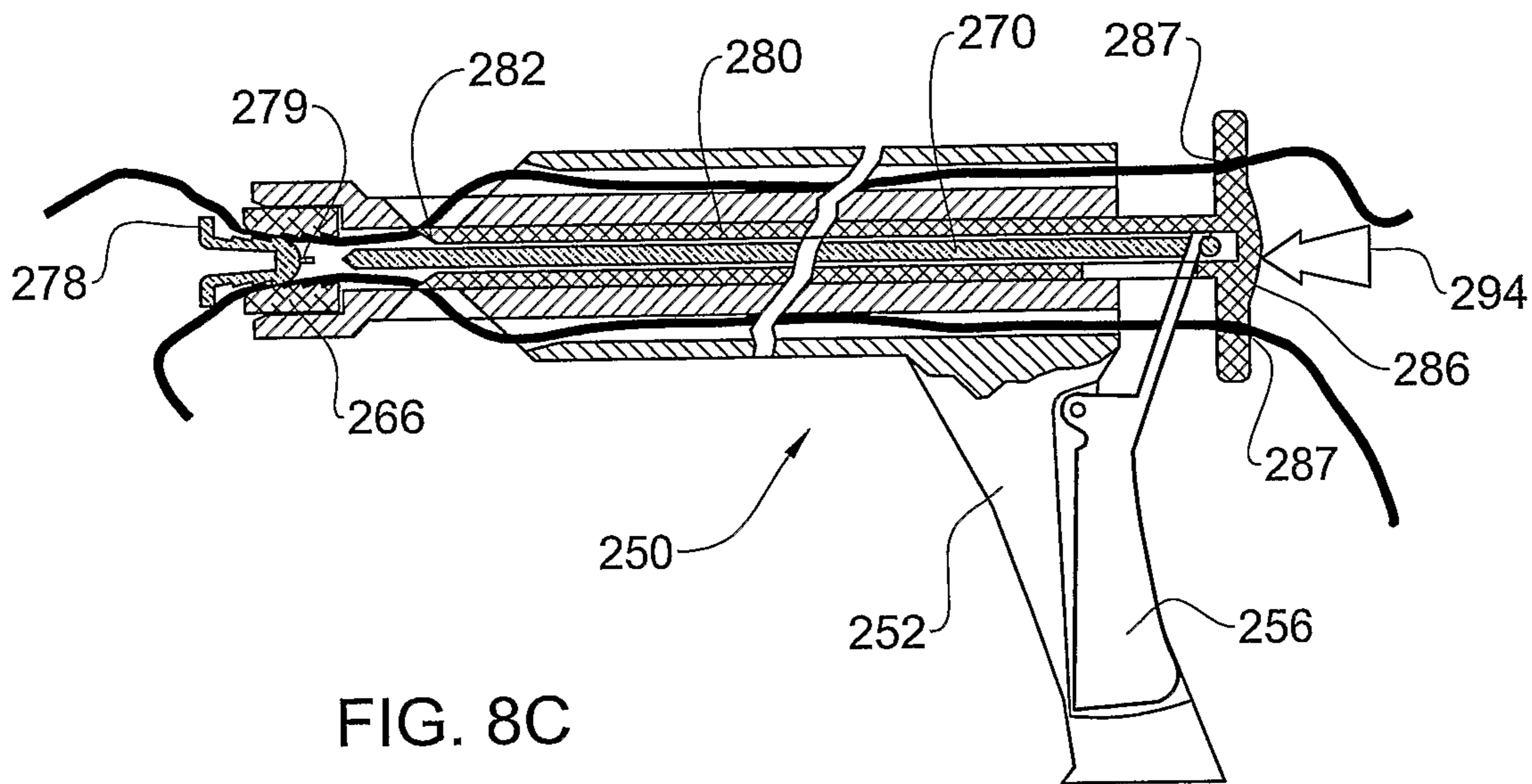

FIG. 8C

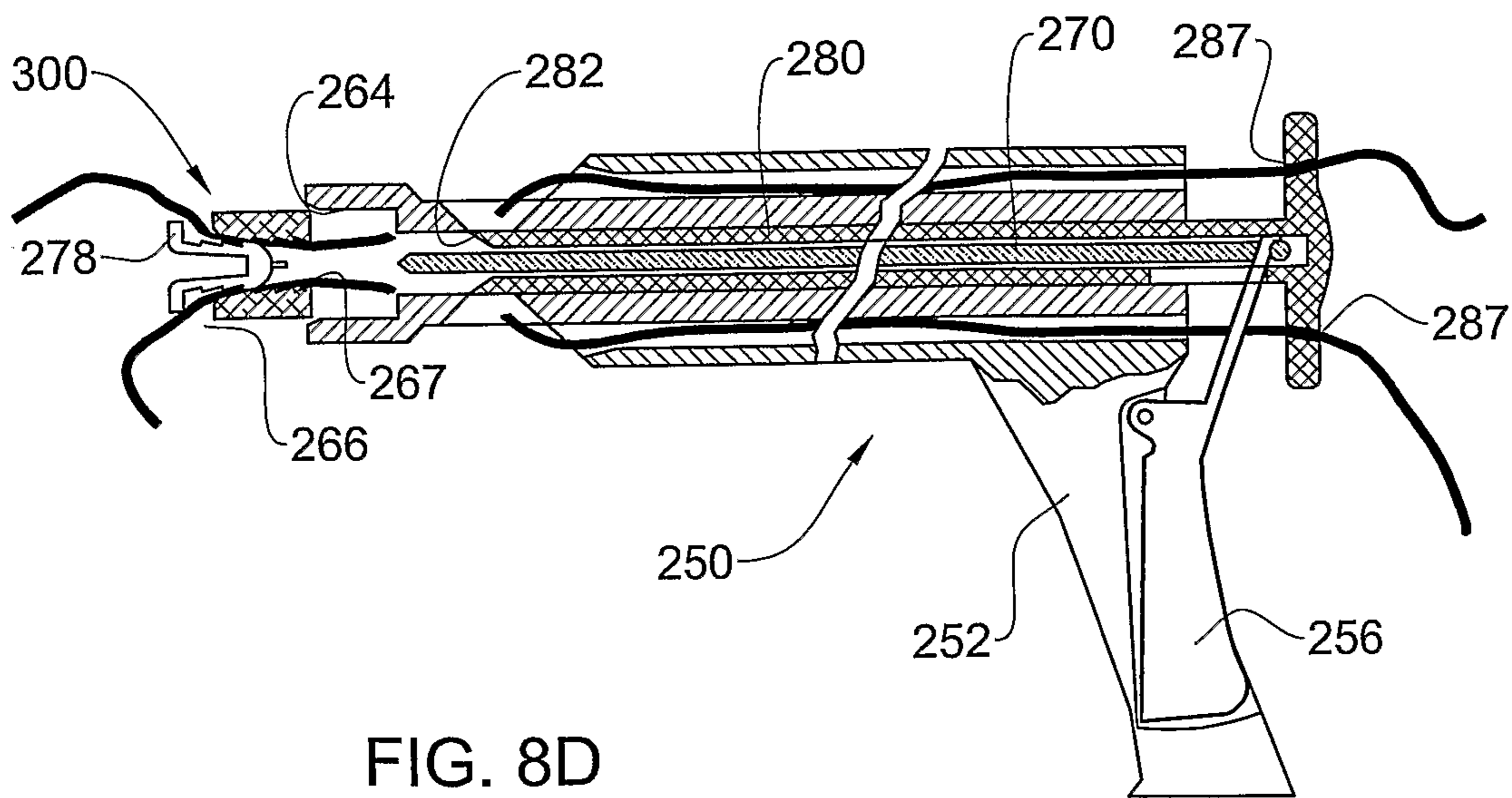

FIG. 8D

