



(86) **Date de dépôt PCT/PCT Filing Date:** 2016/12/08  
 (87) **Date publication PCT/PCT Publication Date:** 2017/06/15  
 (45) **Date de délivrance/Issue Date:** 2020/07/21  
 (85) **Entrée phase nationale/National Entry:** 2018/06/01  
 (86) **N° demande PCT/PCT Application No.:** US 2016/065623  
 (87) **N° publication PCT/PCT Publication No.:** 2017/100453  
 (30) **Priorité/Priority:** 2015/12/09 (US62/265,362)

(51) **Cl.Int./Int.Cl. E04B 1/24** (2006.01),  
**E04B 1/18** (2006.01), **E04B 1/38** (2006.01),  
**E04B 1/98** (2006.01), **E04C 3/04** (2006.01),  
**E04H 9/02** (2006.01)  
 (72) **Inventeur/Inventor:**  
 RICHARDS, PAUL WILLIAM, US  
 (73) **Propriétaire/Owner:**  
 DURAFUSE FRAMES, LLC, US  
 (74) **Agent:** PIASETZKI NENNIGER KVAS LLP

(54) **Titre : SYSTEMES D'ATTACHE POUTRE-POTEAU ET CHARPENTES RESISTANTES AUX MOMENTS ET COMPORTANT CES SYSTEMES**

(54) **Title: BEAM-TO-COLUMN CONNECTION SYSTEMS AND MOMENT-RESISTING FRAMES INCLUDING THE SAME**

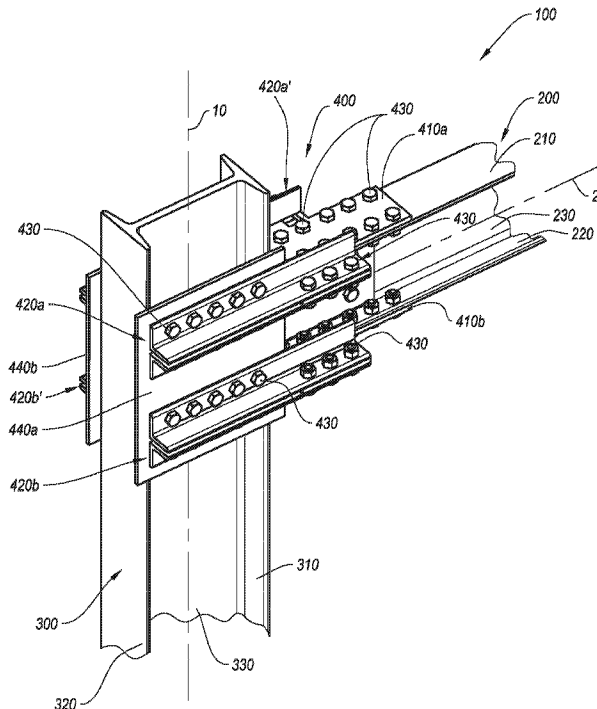

(57) **Abrégé/Abstract:**

Embodiments disclosed herein relate to a beam-to-column connection systems for a moment-resisting frame as well as moment-resisting frames that include such connection systems.

(12) INTERNATIONAL APPLICATION PUBLISHED UNDER THE PATENT COOPERATION TREATY (PCT)

(19) World Intellectual Property  
Organization  
International Bureau(43) International Publication Date  
15 June 2017 (15.06.2017)(10) International Publication Number  
**WO 2017/100453 A1**

## (51) International Patent Classification:

*E04B 1/24* (2006.01)      *E04B 1/98* (2006.01)  
*E04B 1/18* (2006.01)      *E04C 3/04* (2006.01)  
*E04B 1/38* (2006.01)      *E04H 9/02* (2006.01)

## (21) International Application Number:

PCT/US2016/065623

## (22) International Filing Date:

8 December 2016 (08.12.2016)

## (25) Filing Language:

English

## (26) Publication Language:

English

## (30) Priority Data:

62/265,362      9 December 2015 (09.12.2015)      US

(71) Applicant: **BRIGHAM YOUNG UNIVERSITY**  
[US/US]; Technology Transfer Office, 3760 Harold B. Lee  
Library, Provo, Utah 84602 (US).(72) Inventor: **RICHARDS, Paul William**; 288 South 900  
East, Orem, Utah 84097 (US).(74) Agents: **SIMON, Marcus S.** et al.; Dorsey & Whitney  
LLP, 136 S. Main Street, Suite 1000, Salt Lake City, Utah  
84101 (US).(81) Designated States (*unless otherwise indicated, for every kind of national protection available*): AE, AG, AL, AM, AO, AT, AU, AZ, BA, BB, BG, BH, BN, BR, BW, BY, BZ, CA, CH, CL, CN, CO, CR, CU, CZ, DE, DJ, DK, DM, DO, DZ, EC, EE, EG, ES, FI, GB, GD, GE, GH, GM, GT, HN, HR, HU, ID, IL, IN, IR, IS, JP, KE, KG, KH, KN, KP, KR, KW, KZ, LA, LC, LK, LR, LS, LU, LY, MA, MD, ME, MG, MK, MN, MW, MX, MY, MZ, NA, NG, NI, NO, NZ, OM, PA, PE, PG, PH, PL, PT, QA, RO, RS, RU, RW, SA, SC, SD, SE, SG, SK, SL, SM, ST, SV, SY, TH, TJ, TM, TN, TR, TT, TZ, UA, UG, US, UZ, VC, VN, ZA, ZM, ZW.(84) Designated States (*unless otherwise indicated, for every kind of regional protection available*): ARIPO (BW, GH, GM, KE, LR, LS, MW, MZ, NA, RW, SD, SL, ST, SZ, TZ, UG, ZM, ZW), Eurasian (AM, AZ, BY, KG, KZ, RU, TJ, TM), European (AL, AT, BE, BG, CH, CY, CZ, DE, DK, EE, ES, FI, FR, GB, GR, HR, HU, IE, IS, IT, LT, LU, LV, MC, MK, MT, NL, NO, PL, PT, RO, RS, SE, SI, SK, SM, TR), OAPI (BF, BJ, CF, CG, CI, CM, GA, GN, GQ, GW, KM, ML, MR, NE, SN, TD, TG).

## Published:

— *with international search report (Art. 21(3))*

(54) Title: BEAM-TO-COLUMN CONNECTION SYSTEMS AND MOMENT-RESISTING FRAMES INCLUDING THE SAME

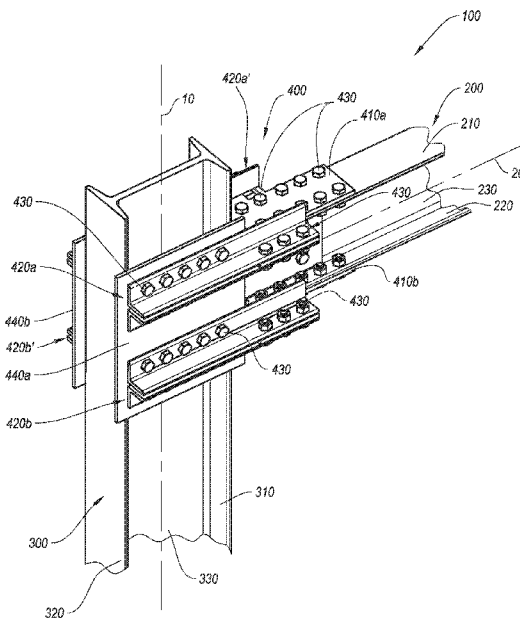

FIG. 1

(57) Abstract: Embodiments disclosed herein relate to a beam-to-column connection systems for a moment-resisting frame as well as moment-resisting frames that include such connection systems.

WO 2017/100453 A1

**BEAM-TO-COLUMN CONNECTION SYSTEMS AND MOMENT-RESISTING  
FRAMES INCLUDING THE SAME**

5

**BACKGROUND**

[0002] Typically, structural beam-to-column connections in moment-resisting frames can be very expensive to build, because they include multiple parts that must be fitted and then welded together. For example, the parts required for the moment-resisting frame may include a column, column continuity plates, column doubler plates, and a beam. The welding between the beam and the column is typically performed in the field and can be particularly expensive. Another connection type includes a flange-plate moment connection and addresses the expense of welding. Generally, however, when the frame experiences a seismic event, the connection between the beam and the column is such that the failure or yielding of the frame occurs at a location on the beam, which is near but not at the connection.

[0003] Accordingly, designers and manufacturers of moment-resisting frame continue to seek improvements thereto.

20

**SUMMARY**

[0004] Embodiments disclosed herein relate to a seismic fuse plate for a moment-resisting frame as well as to a connection system and a moment-resisting frame that include such seismic fuse plate. Specifically, the seismic fuse plate may be configured and positioned such that movement or tilting of the moment-resisting frame exerts shear forces on one or more portions of the seismic fuse plate. For example, as the moment-resisting frame experiences a seismic event (*e.g.*, an event that may exert forces onto the moment-resisting frame, which may tilt or reconfigure the moment-resisting frame from a generally rectangular configuration to a parallelogram configuration), the seismic fuse plate may be subjected to shear force that may preferentially fail the seismic fuse plate instead of the beam and/or column connected by the connection system that includes the seismic fuse plate.

[0005] An embodiment includes beam-to-column connection system that includes a first pair of splice plates configured to be secured to the column and to be spaced from each other along the column at a first distance, and a second pair of splice plates

configured to be secured to the column and opposite to the first pair of splice plates, and to be spaced from each other along the column at the first distance. The beam-to-column connection system also includes a first seismic fuse plate that includes a beam-connection portion configured to connect to a first flange of the beam, a first splice-connection portion longitudinally extending along at least a portion of the beam-connection portion and being configured to connect to and between the first pair of splice plates, and a second splice-connection portion longitudinally extending along at least a portion of the beam-connection portion and being configured to connect to and between the second pair of splice plates at a second location, the distance between the first and second location being greater than the width of the beam. The first seismic fuse plate also includes a first shear portion extending between the first splice-connection portion and the beam-connection portion.

**[0006]** Another embodiment includes a moment-resisting frame that includes a column having a column width, a beam having a beam width, and a beam-to-column connection system connecting the beam to the column. The beam-to-column connection system includes a first pair of splice plates connected to a first side of the column and spaced from each other along the first side of the column at a first distance, a second pair of splice plates connected to a second side of the column and spaced from each other along the first side of the column at the first distance, and a first seismic fuse plate secured between the first pair of splice plates and between the second pair of splice plates. The first seismic fuse plate includes a beam-connection portion connected to the a first flange of the beam, and a first shear portion located between the beam-connection portion and the first pair of splice plates.

**[0007]** Features from any of the disclosed embodiments may be used in combination with one another, without limitation. In addition, other features and advantages of the present disclosure will become apparent to those of ordinary skill in the art through consideration of the following detailed description and the accompanying drawings.

### BRIEF DESCRIPTION OF THE DRAWINGS

**[0008]** The drawings illustrate several embodiments, wherein identical reference numerals refer to identical or similar elements or features in different views or embodiments shown in the drawings.

**[0009]** **FIG. 1** is an isometric partial view of a moment-resisting frame, according to an embodiment;

[0010] FIG. 2A is a top partial view of the moment-resisting frame of FIG. 1;

[0011] FIG. 2B is a front partial view of the moment-resisting frame of FIG. 1;

[0012] FIG. 2C is an end partial view of the moment-resisting frame of FIG. 1;

[0013] FIG. 3A is a schematic front view of the moment-resisting frame of FIG.

5 1 under an example load from a seismic event that delivers energy to the moment-resisting frame and causes minimal deformation of a seismic fuse plate that is included in the moment-resisting frame;

[0014] FIG. 3B is a top view of the seismic fuse plate exposed to the loads shown in FIG. 3A;

10 [0015] FIG. 4A is a schematic front view of the moment-resisting frame of FIG. 1 under another example load from a seismic event that delivers energy to the moment-resisting frame and causes plastic deformation or failure of a seismic fuse plate that is included in the moment-resisting frame;

[0016] FIG. 4B is a top view of the seismic fuse plate exposed to the loads shown  
15 in FIG. 4A;

[0017] FIG. 5 is a top view of a seismic fuse plate, according to an embodiment;

[0018] FIG. 6 is a top view of a seismic fuse plate, according to another embodiment;

[0019] FIG. 7A is a top view of a seismic fuse plate, according to yet another  
20 embodiment;

[0020] FIG. 7B is a cross-sectional view of the seismic fuse plate of FIG. 7A;  
and

[0021] FIG. 8 is a top view of a seismic fuse plate, according to another embodiment.

25

### DETAILED DESCRIPTION

[0022] Embodiments disclosed herein relate to a seismic fuse plate for a moment-resisting frame as well as to a connection system and a moment-resisting frame that includes such seismic fuse plate. Specifically, the seismic fuse plate may be configured and positioned such that movement or tilting of the moment-resisting frame exerts shear  
30 forces on one or more portions of the seismic fuse plate. For example, as the moment-resisting frame experiences a seismic event (*e.g.*, an event that may exert forces onto the moment-resisting frame, which may tilt or reconfigure the moment-resisting frame from a generally rectangular configuration to a parallelogram configuration), the seismic fuse plate may be subjected to shear force that may preferentially fail the seismic fuse plate

instead of the beam and/or column connected by the connection system that includes the seismic fuse plate.

[0023] In some embodiments, the connection system may be configured to prevent or reduce the likelihood of buckling at one or more portions of the beam and/or column connected by the connection system. For example, failure resulting from shear forces experienced by the seismic fuse plate at the connection system may accommodate or allow greater relative rotation or pivoting between the beam and column connected by the connection system (*e.g.*, as compared with a conventional connection system) without failure of the beam and/or column. Facilitating increased tilting between the beam and column connected by the connection system (compared with a conventional connection) without buckling the beam and/or column may prevent failure or deformation of the beam (*e.g.*, which may be more costly to repair than repairing or replacing the connection system). For example, instead of buckling or otherwise plastically deforming the beam, during a seismic event, the seismic fuse plate may experience elastic and/or plastic deformation resulting from the shear forces experienced thereby, while the deformations experienced by the beam and the column may remain in the elastic region, thereby preventing damage to the beam and column. Moreover, one or more portions of the connection system (*e.g.*, the seismic fuse plate) may be replaced. As noted above, replacing a failed or plastically deformed seismic fuse plate may be easier and/or less expensive than replacing a failed or plastically deformed beam or column.

[0024] Generally, the seismic fuse plate may have any number of suitable configurations, such that the seismic fuse plate may be subjected to and/or fail due to shear forces (*e.g.*, in a seismic event) of a selected magnitude. For example, the seismic fuse plate may include at least one shear portion that may selectively fail during a seismic event, may have any suitable shape and/or cross-section that may have a suitable shear strength. Hence, for example, by selecting a suitable shear strength for the shear portion(s) of the seismic fuse plate, the moment-resisting frame may be configured such as to fail due to the shear forces applied at the shear portion of the seismic fuse plate, while the column and beam connected by the connection system may remain undamaged.

[0025] **FIG. 1** is an isometric partial view of a moment-resisting frame 100 according to an embodiment. Specifically, the moment-resisting frame 100 illustrated in **FIG. 1** includes a beam 200 connected to a column 300 by a beam-to-column connection system 400. As described above, the beam-to-column connection system 400 may include one or more seismic fuse plates, such as first and second seismic fuse plates 410a,

410b, which may selectively fail or elastically deform during a seismic event, thereby absorbing energy (*e.g.*, in the a manner that may protect or prevent plastic deformation of the beam 200 and/or of the column 300).

[0026] Generally, the beam-to-column connection system 400 may include any  
5 number of suitable connections that may be configured to connect the first seismic fuse plate 410a and/or second seismic fuse plate 410b to the column 300. In the illustrated embodiment, the first seismic fuse plate 410a may be connected to the column 300 by opposing first and second pairs of splice plates 420a, 420a'. Similarly, the seismic fuse plate 410b may be connected to the column 300 by opposing third pair of splice plates  
10 420b and fourth pairs of splice plates 420b'. In the illustrated embodiment, multiple respective fasteners (*e.g.*, bolts 430) may connect the first and second pairs of splice plates 420a, 420a' to the first seismic fuse plate 410a. Likewise, in the illustrated embodiment, the first seismic fuse plate 410a may be connected to the beam 200 with multiple fasteners (*e.g.*, bolts 430). Similarly, the seismic fuse plate 410b may be  
15 connected to the third pair of splice plates 420b and to the fourth splice plate (not visible in the **FIG. 1**) by one or more fasteners, such as by bolts 430.

[0027] The first and second pairs of splice plates 420a and 420a' may extend outward from the column 300 (*e.g.*, generally in the direction of the beam 200). In the illustrated embodiment, the beam-to-column connection system 400 may include doubler  
20 plates 440a, 440b that may be secured to the column 300. For example, the doubler plates 440a, 440b may be welded or otherwise secured to the column 300 with any number of suitable fastening mechanisms (*e.g.*, fasteners, such as bolts, rivets, etc., welds, etc.). In an embodiment, the first pair of splice plates 420a may be secured to the doubler plate 440a (*e.g.*, the first pair of splice plates 420a may be fastened to the 440a with one  
25 or more fasteners, such as with bolts 430). Similarly, the second first pair of splice plates 420a' may be connected to the 440b (*e.g.*, the second first pair of splice plates 420a' may be fastened to the 440b with one or more fasteners, such as with one or more bolts).

[0028] Also, the third pair of splice plates 420b may be secured to the doubler plate 440a with one or more fasteners (*e.g.*, with one or more bolts 430). Hence, for  
30 example, the first pair of splice plates 420a and the third pair of splice plates 420b may be positioned on the same side of the column 300 and may be spaced apart from each other. Moreover, the second pair of splice plates 420a' and the fourth pair of splice plates 420b' may be located on the same side of the column 300 (*e.g.*, opposite to the respective first pair of splice plates 420a and the third pair of splice plates 420b). Similarly, the second

pair of splice plates 420a' and the fourth splice plates may be spaced apart along the column 300 (*e.g.*, the second first pair of splice plates 420a' may have generally the same longitudinal position along the column 300 as the first pair of splice plates 420a, and the fourth pair of splice plates 420b' may have generally the same longitudinal position along the column 300 as the 420b).

**[0029]** In the illustrated embodiment, the first pair of splice plates 420a is positioned above the third pair of splice plates 420b along the column 300. For example, the first pair of splice plates 420a may secure a portion of the first seismic fuse plate 410a, and the third pair of splice plates 420b may secure a portion of the seismic fuse plate 410b. The first seismic fuse plate 410a may be spaced apart from (*e.g.*, positioned above) the first seismic fuse plate 410b, such that the beam 200 may be positioned between the first and second seismic fuse plates 410a, 410b and secured thereto. For example, as described above the first and second seismic fuse plates 410a, 410b may secure the beam 200 to the column, such that the beam 200 is secured between the first and second seismic fuse plates 410a, 410b.

**[0030]** The beam 200 may be an I-beam that has a top flange 210, a bottom flange 220, and a web 230 extending therebetween. It should be appreciated that the beam 200 may have any number of suitable shapes (*e.g.*, round tube, square tube, etc.). In the embodiment shown in **FIG. 1**, the first seismic fuse plate 410a may be secured to the top flange 210, and the seismic fuse plate 410b may be secured to the bottom flange 220 of the beam 200 (*e.g.*, the beam 200 may be oriented relative to the column 300, such that the top flange 210 and the bottom flange 220 are spaced from each other along a direction that is generally parallel to the longitudinal direction of the column 300). Hence, for example, the first seismic fuse plate 410a and seismic fuse plate 410b may position and orient the beam 200 at a suitable orientation and position relative to the column 300.

**[0031]** Generally, the first seismic fuse plate 410a and the second seismic fuse plate 410b may extend outward from the column 300 in the same direction as the beam 200. In the illustrated embodiment, the first seismic fuse plate 410a and the second seismic fuse plate 410b orient the beam 200 substantially perpendicularly relative to the column 300 (*e.g.*, the column 300 may be oriented along a substantially vertical axis 10, the beam 200 may be oriented generally along a substantially horizontal axis 20, and the vertical and horizontal axes 10, 20 may be substantially perpendicular to each other). In additional or alternative embodiments, the beam 200 may be oriented at any suitable angle relative to the column 300 (*e.g.*, at obtuse or acute angles relative to the column

300). For example, the first, second, and third pairs of splice plates 420a, 420a', 420b, and the fourth splice plates may be secured to the corresponding doubler plates 440a, 440b, such as to form a suitable angle relative to the column 300 and to orient the beam 200 at the suitable angle relative to the column 300.

5 [0032] The first and second pairs of splice plates 420a, 420a', and the third and fourth pairs of splice plates 420b, 420b' may be spaced apart by a suitable distance, such as to accommodate the beam 200 of any selected thickness (*e.g.*, thickness that may be defined by distance between the outer surfaces of the top flange 210 and bottom flange 220). That is, the first seismic fuse plate 410a and the second seismic fuse plate 410b  
10 may be positioned at suitable distance along the column 300 to secure the beam 200 of any selected thickness. Moreover, the beam-to-column connection system 400 may be positioned at any suitable height along the column 300, such that the beam 200 is positioned at a corresponding suitable height.

[0033] In the illustrated embodiment, the column 300 is an I-beam that includes  
15 flanges 310, 320 and a web 330 therebetween. For example, the column 300 may be axially oriented and/or centered about the axis 10, such that axis 10 is positioned midway between the flanges 310 and 320. In an embodiment, the flanges 310, 320 may be generally perpendicular to the axis 20 that may be generally perpendicular to the axis 10 (*e.g.*, the longitudinal direction of the beam 200 may be generally perpendicular to the  
20 outer surfaces of the flanges 310 and 320). It should be appreciated, however, that the beam 200 may have any number of suitable orientations relative to the shape of the column 300 (*e.g.*, relative to the flanges 310 and/or 320). Moreover, the column 300 may have any number of suitable cross-sectional shapes (*e.g.*, tubular rectangle, tubular round, etc.).

25 [0034] In the illustrated example, the first seismic fuse plate 410a and seismic fuse plate 410b are connected to the column 300 by the first and second pairs of splice plates 420a, 420a' and the third pair of splice plates 420b and fourth splice plates (respectively) that are connected to the doubler plates 440a, 440b. In particular, in the illustrated embodiment, the 440a and 440b may be connected to the column 300 with one  
30 or more welds (*e.g.*, fillet welds may connect the 440a and 440b to the flanges 310 and 320). Generally, however, the first seismic fuse plate 410a and the second seismic fuse plate 410b may be connected to the column 300 with any number of suitable connect systems and mechanism. Examples of suitable connection systems and mechanisms are

more fully described in PCT International Application No. PCT/US2015/047006 filed on 26 August 2015.

[0035] FIGS. 2A-2C are partial top, front, and end views, respectively, of the moment-resisting frame 100. Conventionally, the beam secured to the column may have a weakened portioned (*e.g.*, near the connection location) that may fail or plastically deform during a seismic event. For example, conventional moment-resisting frames or frame connections may be configured in a manner that allows one or more portions of the beam to plastically deform, thereby absorbing some of the energy that the seismic event delivered to the moment-resisting frame (*e.g.*, to avoid critical damage to or failure of the frame).

[0036] In particular, for example, the first seismic fuse plate 410a and the second seismic fuse plate 410b may fail or plastically deform, to absorb energy from the seismic event, due to shear forces experienced thereby (*e.g.*, forces in a direction generally parallel to the axis 20). As described above, the seismic fuse plate(s), such as the first and second seismic fuse plates 410a, 410b may absorb some of the energy that a seismic event may deliver to the moment-resisting frame 100. Specifically, for example, dissipating the energy from the seismic event by allowing the seismic fuse plate(s) to deform and/or at least partially shear may prevent or avoid deformations to the beam 200 and/or to the column 300 (*e.g.*, that may otherwise result from the seismic event).

[0037] In an embodiment, the beam 200 may be spaced from the column 300 by a space 30. Hence, for example, the first seismic fuse plate 410a and the second seismic fuse plate may experience shear forces as the beam 200 moves toward and/or away from the column 300 during a seismic event. As described below in more detail, positioning the beam 200 spaced from the column 300 along the axis 20 (*e.g.*, by a suitable distance) and secured to the column 300 by the beam-to-column connection system 400 may allow the beam 200 to move in a direction that is generally parallel to the axis 20 as the frame tilts. In some embodiments, the axis 20 together with the beam 200 may change orientation relative to the column 300 and relative to the axis 10, as the moment-resisting frame 100 tilts during a seismic event. Furthermore, the beam 200 may apply or produce shear force on the first seismic fuse plate 410a and the second seismic fuse plate 410b, as the frame tilts and the beam 200 is forced to change orientation relative to the column 300 (*e.g.*, from a generally perpendicular orientation to forming an acute and/or obtuse angle relative thereto).

[0038] In some embodiments, the first seismic fuse plate 410a and the second seismic fuse plate 410b may have similar or the same configurations. Hence, for the sake of simplicity, the following describes to the first seismic fuse plate 410a, but would be similarly applicable to the second seismic fuse plate 410b. For example, the seismic fuse plate 410a may have at least one portion that is wider than the width of the beam 200 (e.g., a portion of the seismic fuse plate 410a that is near the column 300 may be wider than the width of the beam 200). Moreover, in some embodiments, the first pair of splice plates 420a and the second pair of splice plates 420a' may be secured to the seismic fuse plate 410a at the portion that is wider than the beam 200 (e.g., the first pair of splice plates 420a and the second first pair of splice plates 420a' may be positioned about the beam 200 such as to define a distance therebetween that is greater than the width of the beam 200).

[0039] In an embodiment, at least one portion of the seismic fuse plate 410a may be positioned between the beam 200 one an outer periphery of the beam 200 (e.g., without contacting any other portion of the beam 200, column 300, other portions of the beam-to-column connection system 400, or combination thereof). The seismic fuse plate 410a may include first and second shear portions 411a, 411a'. Specifically, for example, the first shear portion 411a may extend between a beam-connection portion (e.g., portion of the seismic fuse plate 410a that may be connected to the beam 200) and a splice-connection portion (e.g., portion of the seismic fuse plate 410a that is secured between the first pair of splice plates 420a). Similarly, the second shear portion 411a' may extend between the beam-connection portion (e.g., portion of the seismic fuse plate 410a that may be connected to the beam 200) and another splice-connection portion (e.g., portion of the seismic fuse plate 410a that is secured between the second pair of splice plates 420a'). Hence, under some operating conditions, the first and second shear portions 411a and/or 411a' may fail, as the beam 200 is forced away from and/or toward the column 300.

[0040] In some embodiments, the beam-to-column connection system 400 may include a blocker plate 450 that may prevent or limit movement of the beam 200 toward the column 300. For example, as shown in **FIGS. 2A-2C**, the blocker plate 450 may be secured to the beam 200 (e.g., to the web of the beam 200) and may abut the column 300 (e.g., may abut the flange of the column 300). In the illustrated example, the blocker plate 450 is fastened to the beam 200 with fasteners. It should be appreciated, however, that the blocker plate 450 may be attached to the beam 200 with any number of suitable connections (e.g., weld, rivets, etc.).

[0041] Moreover, the blocker plate 450a may be detached from the beam 200. For example, the blocker plate 450a may be attached to the beam 200 after the beam 200 is positioned at the suitable location relative to the column 300 (*e.g.*, without the blocker plate 450a, the beam 200 may be positioned between two opposing columns, such that the beam 200 is suitably shorter than the distance between the two opposing columns, to facilitate installation of the beam 200). Furthermore, the blocker plate 450 may prevent or limit the beam 200 from moving toward the column 300 but may not stop or limit movement of the beam 200 away from the column 300.

[0042] In other words, the blocker plate 450 may provide additional restraint (*e.g.*, in addition to the seismic fuse plate 410a) for the beam 200 to move toward the column 300. It should be appreciated, however, that beam 200 may be restrained from moving toward the column 300 with any number additional or alternative elements (*e.g.*, a blocker plate or block may be secured to the column 300 and may abut the end of the beam 200). Moreover, the beam 200 may be sized such that the end of the beam 200 abuts the column 300.

[0043] In an embodiment, in a seismic event that applies lateral load onto the moment-resisting frame 100 (*e.g.*, in directions along the axis 20), the seismic fuse plate 410a may experience a greater load when the beam 200 experiences forces in the direction away from the column 300 than when the beam 200 experiences forces in the direction toward the column 300. As such, under some operating conditions, the seismic fuse plate 410a may be more prone to failure when the beam 200 is forced away from the column 300. In other words, the beam-to-column connection system 400 may be configured such that the seismic fuse plate 410a may selectively plastically deform and/or fail in a single direction (*e.g.*, due to shear forces at the first and second shear portions 411a, 411a'). As described above, in some conventional frames, the beam may be selectively weakened near the connection to the column; such weakened portion may fail in response to repeated compressive and tensile loads thereof (*e.g.*, due to buckling).

[0044] **FIG. 3A** is a schematic front view of the moment-resisting frame 100 under an example load from a seismic event. **FIG. 3B** shows the forces experienced by the seismic fuse plate 410a of the beam-to-column connection system 400, according to the loading shown in **FIG. 3A**. The moment-resisting frame 100 may experience a seismic event that may produce lateral forces that generally push the moment-resisting frame 100 laterally to the left (as shown in **FIG. 3A**) and/or in the opposite direction, to the right.

[0045] The moment-resisting frame 100 may include a beam 200 connected to and between opposing columns 300 and 300a, thereby forming a substantially rigid structure that may resist lateral forces (*e.g.*, the moment-resisting frame 100 may be included in a structure, such as a building, and may provide suitable resistance to lateral movements, which may prevent collapse of the building under certain conditions). As described above, the beam 200 may be connected to the column 300 by the beam-to-column connection system 400. Furthermore, the beam 200 may be connected to the column 300a by a beam-to-column connection system 400a that may be similar to or the same as the beam-to-column connection system 400 (*e.g.*, as described above).

10 [0046] In the illustrated example, the beam-to-column connection system 400 includes the seismic fuse plate 410a and seismic fuse plate 410b that experience shear load (as shown in **FIG. 3B** in connection with the 410a). Conversely, the beam-to-column connection system 400a may include seismic fuse plate 410c and seismic fuse plate 410d (that may be similar to or the same as the respective seismic fuse plate 410a and seismic fuse plate 410b), which may experience compressive load. Moreover, as mentioned above, the beam-to-column connection system 400 and/or the beam-to-column connection system 400a may include one or more blocker plates that may provide additional compressive strength to the beam-to-column connection system 400 (*e.g.*, the seismic fuse plate 410a and seismic fuse plate 410b may experience greater shear loads than the shear loads experienced by the seismic fuse plate 410c and seismic fuse plate 410d).

[0047] As described above, the seismic fuse plate 410a may include the shear portions 411a and 411a' that may be positioned and configured such as not to contact any other portion of the beam 200, column 300, beam-to-column connection system 400, or combinations thereof. For example, the seismic fuse plate 410a may include a beam-connection portion 412 that may generally extend along the middle of the seismic fuse plate 410a and may be connected to the beam. The seismic fuse plate 410a also may include a first splice-connection portion 413a and a second splice-connection portion 413a'. In an embodiment, the first splice-connection portion 413a may be secured to the first pair of splice plates and the second splice-connection portion 413a' may be secured to the second pair of splice plates. For ease of identification, **FIG. 3B** illustrates the first and second shear portions 411a and 411a' without any shading, the beam-connection portion 412a is shown with a first cross-hatch, and the first and second splice-connection portion 413a, 413a' are shown with a second cross-hatch (the cross-hatches only

demarcate the respective portions and are not used to indicate a cross-section at the cross-hatched locations).

[0048] In an embodiment, the first and second shear portions 411a and 411a' may be positioned between the portions of the seismic fuse plate 410a, which may be secured to the beam or to the column. For example, the first shear portion 411a may be positioned between the beam-connection portion 412a (secured to the beam) and the first splice-connection portion 413a (secured to the first pair of splice plates). Likewise, the second shear portion 411a' may be positioned on an opposite side of the seismic fuse plate 410a and between the beam-connection portion 412a (secured to the beam) and the second splice-connection portion 413a' (secured to the second pair of splice plates).

[0049] Hence, for example, as the beam 200 and the column 300 experience forces in the opposite directions (as shown in **FIGS. 3A-3B**), the beam-connection portion 412a on the one hand and the first splice-connection portion 413a and second splice-connection portion 413a' on the other hand may experience the same forces as the beam 200 and the column 300, respectively (translated thereto through the splice plates and the beam connection). Moreover, as the first shear portion 411a is positioned between the beam-connection portion 412 and the 413a, the first shear portion 411a may experience shear forces. Similarly, as the second shear portion 411a' is positioned between the beam-connection portion 412 and the 413a, the second shear portion 411a' may experience shear forces (*e.g.*, which may be similar to or the same as the shear forces experienced at the first shear portion 411a).

[0050] **FIG. 4A** is a schematic illustration that shows the moment-resisting frame 100 after the seismic fuse plate 410a and the seismic fuse plate 410b deform (*e.g.*, plastically or elastically deform) to facilitate lateral tilting of the moment-resisting frame 100. It should be appreciated that the moment-resisting frame 100 is not shown to scale in **FIG. 4A**. **FIG. 4B** the deformation of the seismic fuse plate 410a resulting from the tilt of the moment-resisting frame 100 shown in **FIG. 4A**. In particular, as shown in **FIG. 4B**, the first and second shear portions 411a and 411a' may be deformed (plastically or elastically) due to the shear stress experienced thereat.

[0051] Generally, the amount of deformation and/or the forces required to produce the deformation (*e.g.*, such as to plastically deform or fail the first and second shear portions 411a and/or 411a' of the seismic fuse plate 410a and/or corresponding portions of the seismic fuse plate 410b) may vary from one embodiment to the next and may depend on the shape and size of the first and second shear portions 411a, 411a',

modulus of elasticity of the material of the seismic fuse plate 410 and/or material of the first and second shear portions 411a, 411a', etc.

[0052] As described above, in some embodiment, the moment-resisting frame may have two or more beam-to-column connection systems that include at least one seismic fuse plate (*e.g.*, two opposing beam-to-column connection systems). Additionally or alternatively, moment-resisting frames may include a single beam-to-column connection system with at least one seismic fuse plate. For example, a moment-resisting frame may include two opposing columns and a beam connected thereto; a beam-to-column connection system (*e.g.*, as described above) may connect the beam to a first column, and another connection (*e.g.*, another rigid connection, such as a welded connection) may connect the beam to a second column.

[0053] The seismic fuse plate 410a may have a plate-like configuration of a selected thickness. For example, the thickness of the seismic fuse plate 410a may be selected such that the first and second shear portions 411a and 411a' have a suitable or selected failure point or force at which the first and second shear portions 411a and 411a' plastically deform. **FIG. 5** is a top view of the seismic fuse plate 410a according to an embodiment. As shown in **FIG. 5** the seismic fuse plate 410a may have openings 414a extending through the thickness of the seismic fuse plate 410a. In particular, for example, the openings 414a may weaken the first and second shear portions 411a and 411a', such that the first and second shear portions 411a and 411a' have suitable strength (*e.g.*, such that the first and second shear portions 411a and 411a' may deform to absorb energy of a seismic event and prevent deformation or damage to the beam and/or column connected thereby). In some embodiments, the shear portions may have other suitable shapes and sizes, as described below.

[0054] Also, as described above, the seismic fuse plate 410a may be fastened to the beam and to the splice plates. Hence, for example, the seismic fuse plate 410a may include fastener holes 415a at suitable locations for fastening the seismic fuse plate 410a. Generally, however, the seismic fuse plate 410a may be fastened to the beam and to the splice plates with any number of suitable connections (*e.g.*, weld, rivets, etc.). In some embodiments, the seismic fuse plate may have no holes or openings for fasteners.

[0055] It should be appreciated, however, that the shear portions of the seismic fuse plate may have any number of suitable configurations. **FIG. 6** is a top view of a seismic fuse plate 410b according to an embodiment. Except as otherwise described herein, the seismic fuse plate 410b may be similar to or the same seismic fuse plate 410a

(**FIG. 5**). For example, the seismic fuse plate 410b may include first and second shear portions 411b and 411b' that may be defined by one or more cutouts extending from the edges of the seismic fuse plate 410b (*e.g.*, by the cutouts 416b, 417b and cutouts 416b', 417b', respectively).

5 **[0056]** Moreover, in some embodiments, the shear portions may have a smaller thickness than other portions of the seismic fuse plate. **FIG. 7A** is a top view of a seismic fuse plate 410c according to an embodiment. **FIG. 7B** is a cross-sectional view of the seismic fuse plate 410c, as indicated in **FIG. 7A**. Except as otherwise described herein, the seismic fuse plate 410c may be similar to or the same any of the seismic fuse plates  
10 410a, 410b (**FIGS. 5-6**). For example, the seismic fuse plate 410c may include first and second shear portions 411c, 411c' that may have one or more portions with smaller thicknesses than beam-connection portion 412c and/or first and second splice-connection portions 413c, 413c'.

**[0057]** Furthermore, the seismic fuse plate may have any number of suitable  
15 configurations. In an embodiment, where the shear portions 411c, 411c' of the seismic fuse plate may have selected strength, such as to produce a controlled plastic deformation and/or failure thereat. For example, the shear portions 411c, 411c' may have a suitable or selected thickness, such that the shear portions 411c, 411c' may deform or fail in response to selected shear forces applied thereto.

20 **[0058]** **FIG. 8** is a top view of a seismic fuse plate 100d, according to an embodiment. Except as otherwise described herein, the seismic fuse plate 410d may be similar to or the same any of the seismic fuse plates 410a, 410b, 410c (**FIGS. 5-7B**). For example, the seismic fuse plate 100d may have first and second shear portions 411d, 411d', a beam-connection portion 412d, and first and second splice-connection portions  
25 412d, 412d', which may be similar to the respective first and second shear portions 411a, 411a', a beam connection portion 412a, and first and second splice-connection portions 412a, 412a' of the seismic fuse plate 100d (**FIG. 3B**). In the illustrated example, the first and second shear portions 411d, 411d', the beam-connection portion 412d, and first and second splice-connection portions 412d, 412d' may have generally the same lengths (*e.g.*,  
30 may extend between opposing edges 416d, 416d' of the seismic fuse plate 410d). Moreover, it should be appreciated that the first and second shear portions 411d, 411d', the beam-connection portion 412d, and first and second splice-connection portions 412d, 412d' may have any suitable widths (*e.g.*, dimensions or sized that are generally perpendicular to the respective lengths). For example, the width of the beam-connection

portion 413d may be generally the same as the width of one or more flanges of a beam. Moreover, the first and second shear portions 411d, 411d', the beam-connection portion 412d, and first and second splice-connection portions 412d, 412d' may have substantially the same widths as one another or different widths.

5    **[0059]**       In the illustrated embodiments in **FIGS. 2A-8**, the first and second seismic fuse plates (*e.g.*, the first and second seismic plates 410a, 410b shown in **FIGS. 2A-2B**) include openings or cutouts therein. However, in other embodiments, one or both of the first or second seismic fuse plates of any of the moment-resistant frames and beam-to-  
10 imperforate.

**[0060]**       While various aspects and embodiments have been disclosed herein, other aspects and embodiments are contemplated. The various aspects and embodiments disclosed herein are for purposes of illustration and are not intended to be limiting.

## CLAIMS

What is claimed is:

1. A beam-to-column connection system, comprising:
  - a first pair of splice plates configured to be secured to the column and to be spaced from each other along the column at a first distance;
  - a second pair of splice plates configured to be secured to the column and opposite to the first pair of splice plates, and to be spaced from each other along the column at the first distance;
  - a first seismic fuse plate including:
    - a beam-connection portion configured to connect to a first flange of the beam;
    - a first splice-connection portion longitudinally extending along at least a portion of the beam-connection portion and being configured to connect to and between the first pair of splice plates at a first location;
    - a second splice-connection portion longitudinally extending along at least a portion of the beam-connection portion and being configured to connect to and between the second pair of splice plates at a second location, the distance between the first and second locations being greater than the width of the beam; and
    - a first shear portion extending between the first splice-connection portion and the beam-connection portion, the first shear portion configured to selectively fail during a seismic event.
2. The beam-to-column connection system of claim 1, wherein the first seismic fuse plate includes a second shear portion extending between the second splice-connection portion and the beam-connection portion.
3. The beam-to-column connection system of claim 1, wherein the first shear portion has one or more openings extending therethrough.
4. The beam-to-column connection system of claim 1, wherein:
  - one or more of the first splice-connection portion or the second splice-connection portion of the first seismic fuse plate have one or more openings extending therethrough; and
  - one or more of the first pair of splice plates or the second splice plates have one or more openings extending therethrough and corresponding to the openings in the first or second splice-connection portions of the first seismic fuse plate.

5. The beam-to-column connection system of claim 1, further comprising a first doubler plate sized and configured to be secured to the column, the first pair of splice plates being configured to be secured to the first doubler plate.
6. The beam-to-column connection system of claim 5, wherein:
  - the first pair of splice plates have one or more openings; and
  - the first doubler plate has one or more openings that correspond to the one or more openings of the first pair of splice plates.
7. The beam-to-column connection system of claim 1, further comprising:
  - a third pair of splice plates configured to be secured to the column and to be spaced from each other along the column at a second distance;
  - a fourth pair of splice plates configured to be secured to the column and to be spaced from each other along the column at the second distance;
  - a second seismic fuse plate including:
    - a beam-connection portion configured to connect to a second flange of the beam;
    - a first splice-connection portion longitudinally extending along at least a portion of the beam-connection portion and being configured to connect to and between the third pair of splice plates;
    - a second splice-connection portion longitudinally extending along at least a portion of the beam-connection portion and being configured to connect to and between the fourth pair of splice plates at a second location, the distance between the first and second location being greater than the width of the beam; and
    - a first shear portion extending between the first splice-connection portion and the beam-connection portion.
8. The beam-to-column connection system of claim 7, further comprising:
  - a first doubler plate sized and configured to be secured to the column, the first pair of splice plates being configured to be secured to the first doubler plate; and
  - a second doubler plate sized and configured to be secured to the column, the second pair of splice plates being configured to be secured to the first doubler plate.

9. A moment-resisting frame, comprising:
  - a column having a column width;
  - a beam having a beam width; and
  - a beam-to-column connection system connecting the beam to the column, the beam-to-column connection system including:
    - a first pair of splice plates connected to a first side of the column and spaced from each other along the first side of the column at a first distance;
    - a second pair of splice plates connected to a second side of the column and spaced from each other along the first side of the column at the first distance;
    - a first seismic fuse plate secured between the first pair of splice plates and between the second pair of splice plates, the first seismic fuse plate including:
      - a beam-connection portion connected to a first flange of the beam; and
      - a first shear portion located between the beam-connection portion and the first pair of splice plates, the first shear portion configured to selectively fail during a seismic event.
10. The moment-resisting frame of claim 9, wherein the first seismic fuse plate is fastened to the first pair of splice plates and to the second pair of splice plates.
11. The moment-resisting frame of claim 9, wherein the first shear portion has one or more openings extending therethrough.
12. The moment-resisting frame of claim 9, wherein the beam-to-column connection system includes a first doubler plate that is secured to a first side of the beam, the first pair of splice plates being secured to the doubler plate.
13. The moment-resisting frame of claim 12, wherein the beam-to-column connection system includes a second doubler plate that is secured to a second side of the beam, the second pair of splice plates being secured to the doubler plate.
14. The moment-resisting frame of claim 13, wherein the first and second doubler plates are welded to the column.
15. The moment-resisting frame of claim 13, wherein the beam-to-column connection system includes:
  - a third pair of splice plates secured to the first doubler plate;

a fourth pair of splice plates secured to the second doubler plate; and

a second seismic fuse plate including a beam-connection portion secured between the third and fourth splice plates and secured to a second flange of the beam.

16. The moment-resisting frame of claim 15, wherein the second seismic fuse plate includes a first shear portion located between the beam-connection portion and the third pair of splice plates.

17. The moment-resisting frame of claim 15, wherein at least one of the first and third pairs of splice plates are fastened to the first doubler plate.

18. The moment-resisting frame of claim 9, wherein the first seismic fuse plate includes a second shear portion located between the beam-connection portion and the second pair of splice plates.

19. The moment-resisting frame of claim 18, wherein the second shear portion has one or more openings extending therethrough.

20. The moment-resisting frame of claim 9, further comprising another column, the beam being connected to the another column.

21. The moment-resisting frame of claim 9, further comprising another beam-to-column connection system connecting the beam to the another column, the beam-to-column connection system including:

a first pair of splice plates connected to a first side of the column and spaced from each other along the first side of the column at a first distance;

a second pair of splice plates connected to a second side of the column and spaced from each other along the first side of the column at the first distance;

a first seismic fuse plate secured between the first pair of splice plates and between the second pair of splice plates, the first seismic fuse plate including:

a beam-connection portion connected to a first flange of the beam; and

a first shear portion located between the beam-connection portion and the first pair of splice plates.

1 / 8

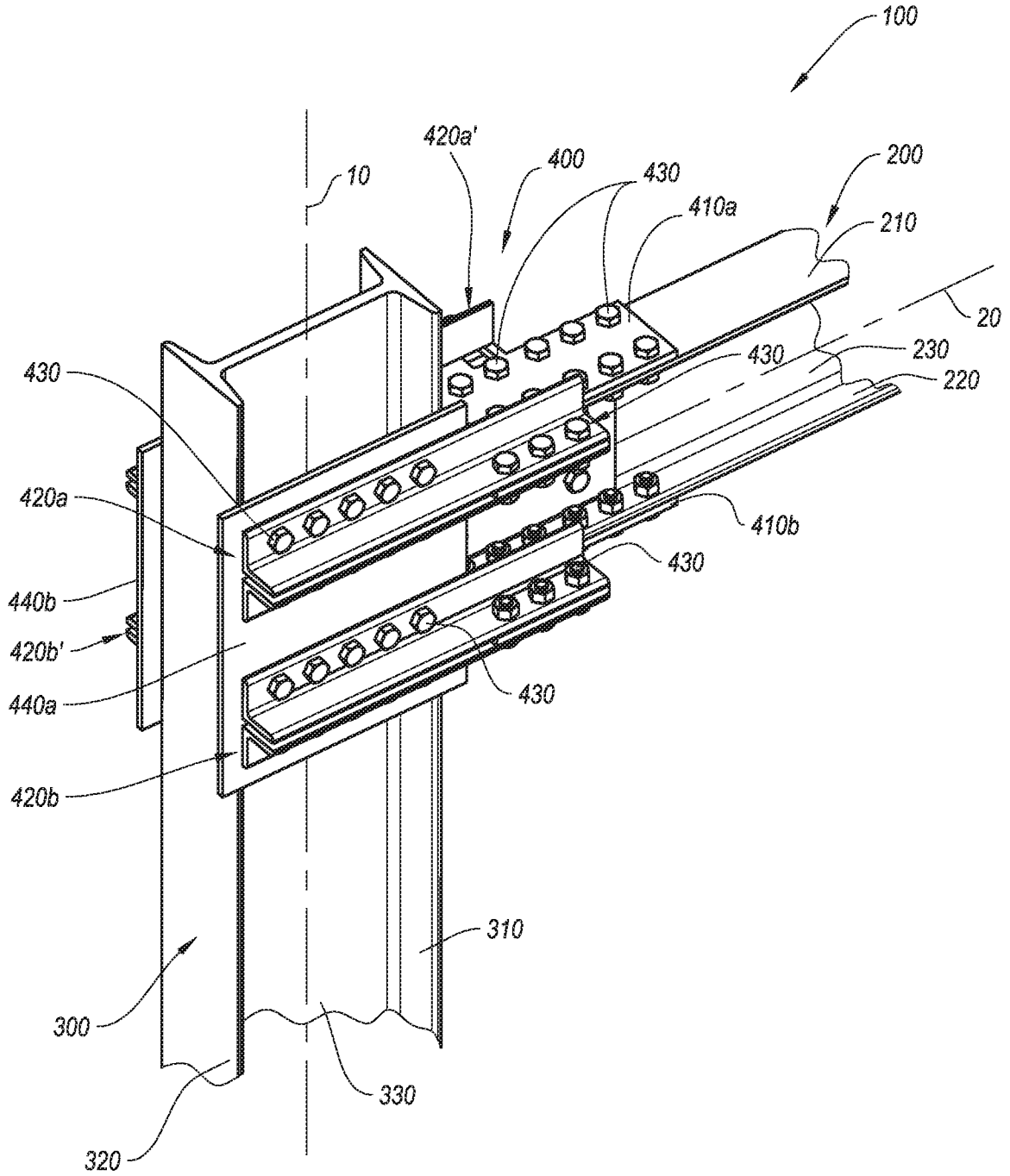

FIG. 1

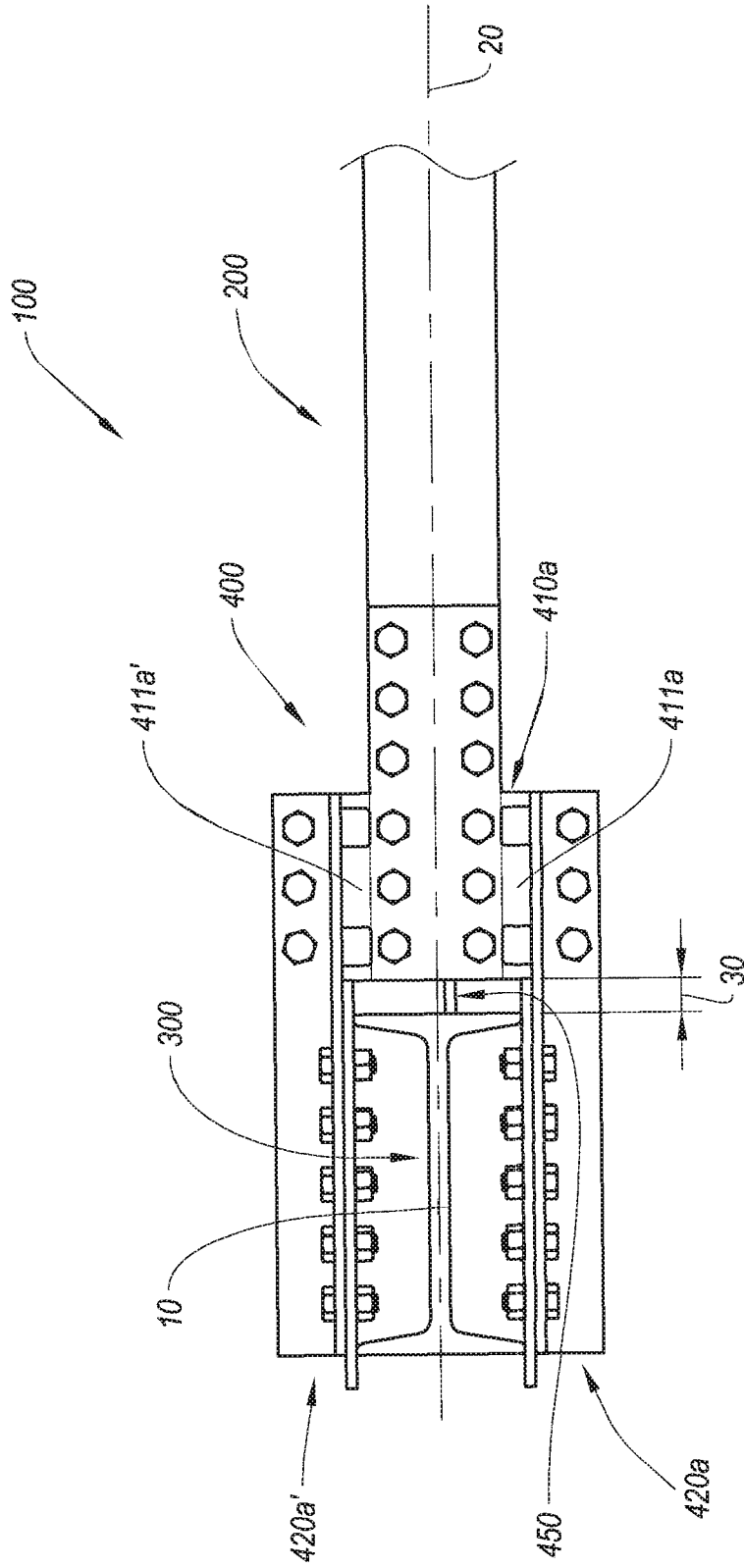

FIG. 2A

3/8

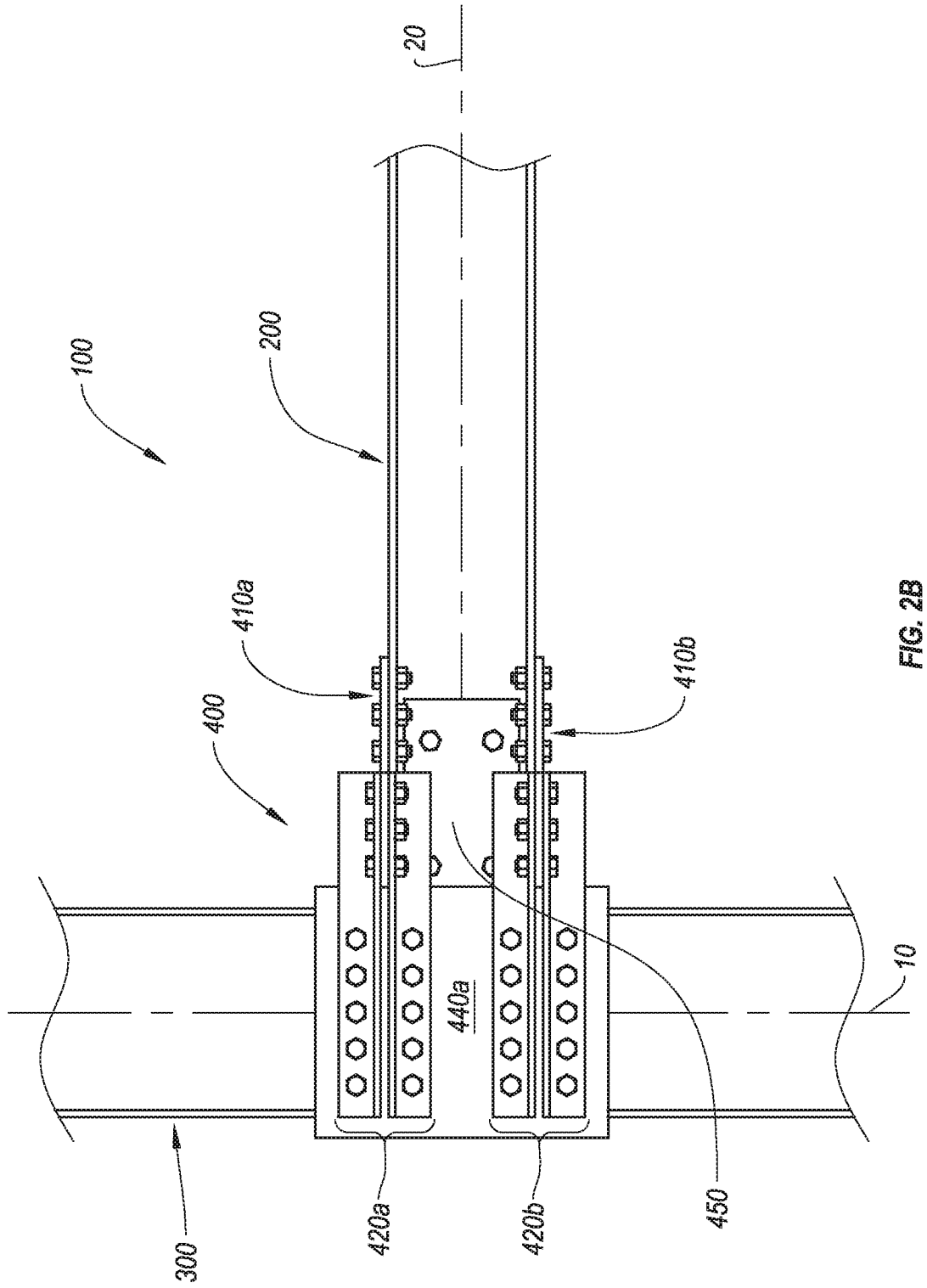

FIG. 2B

4 / 8

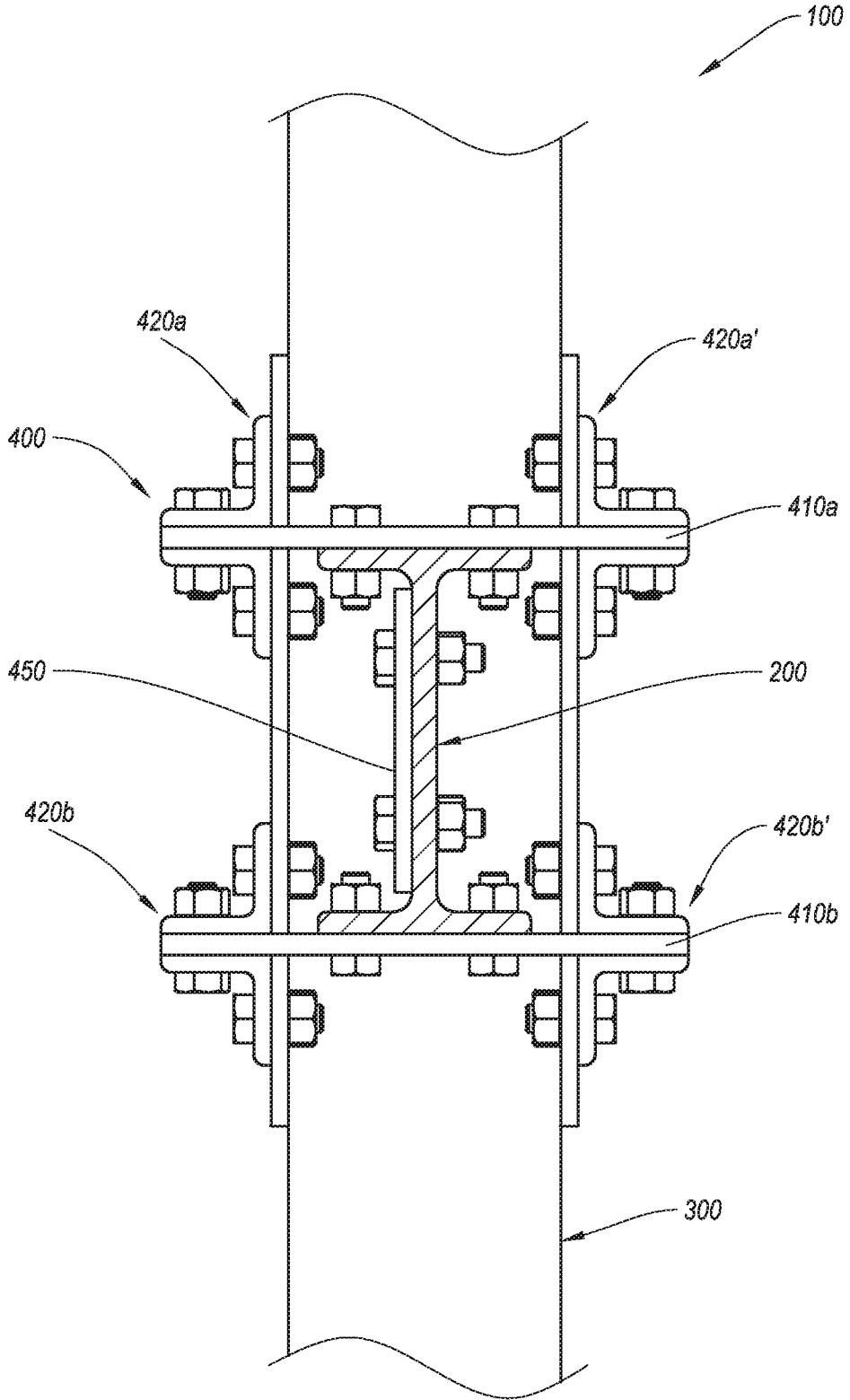

FIG. 2C

5 / 8

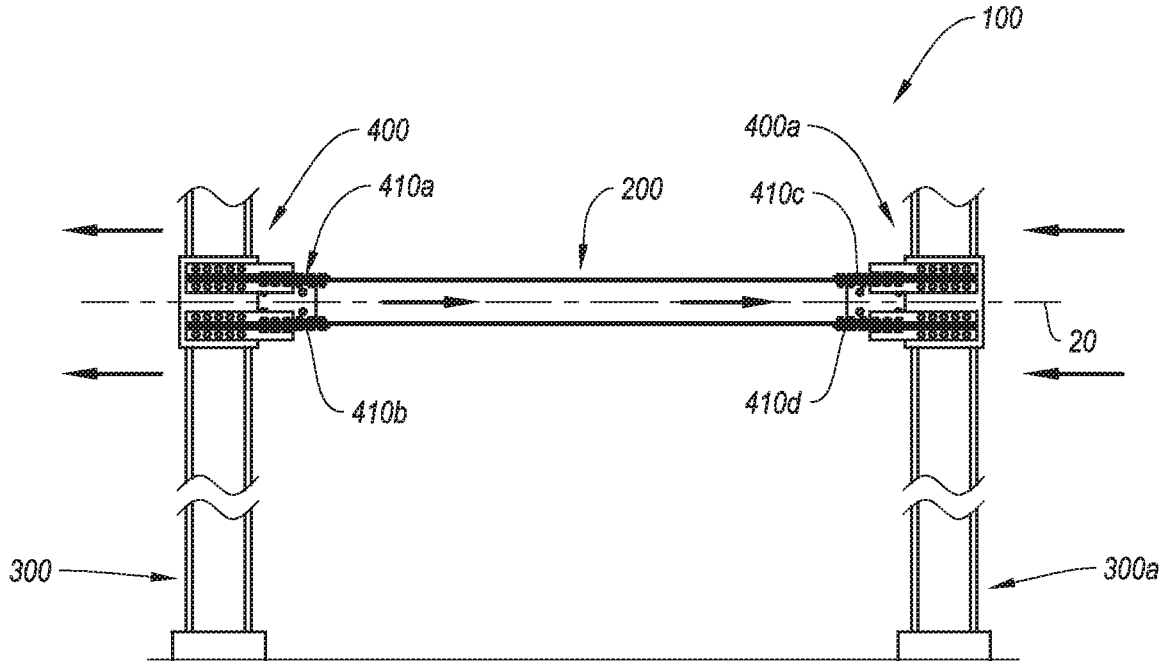

FIG. 3A

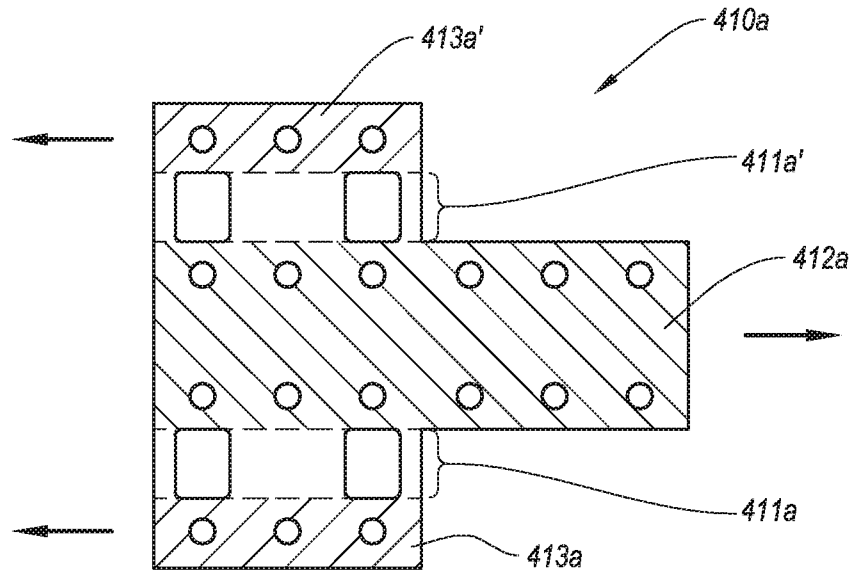

FIG. 3B

6 / 8

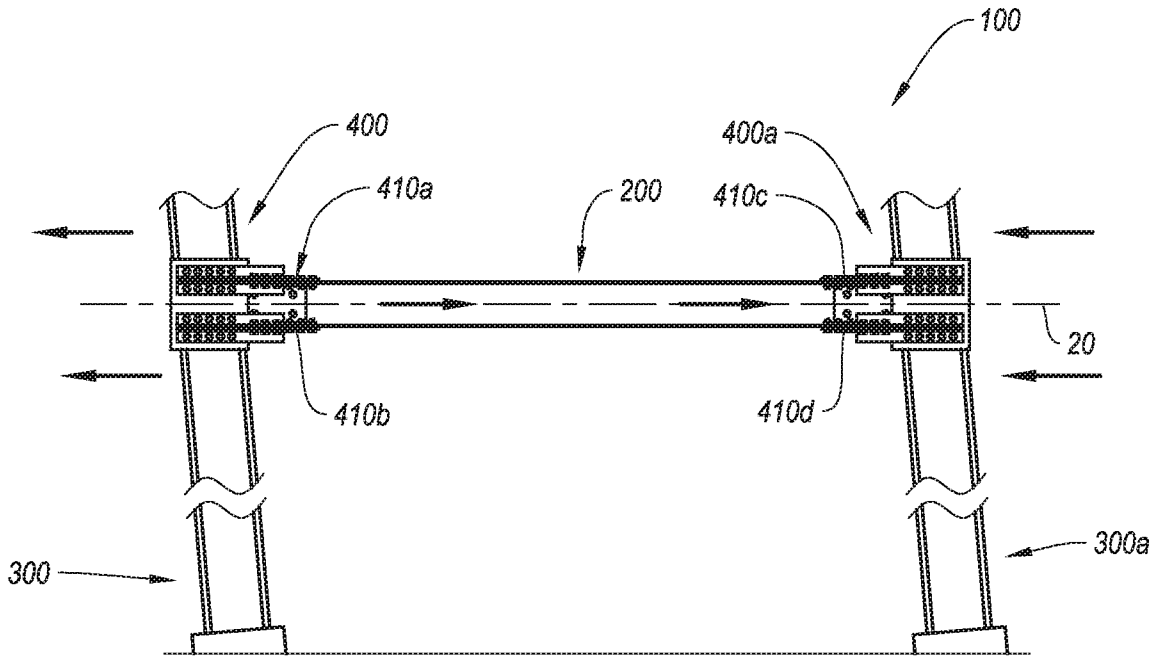

FIG. 4A

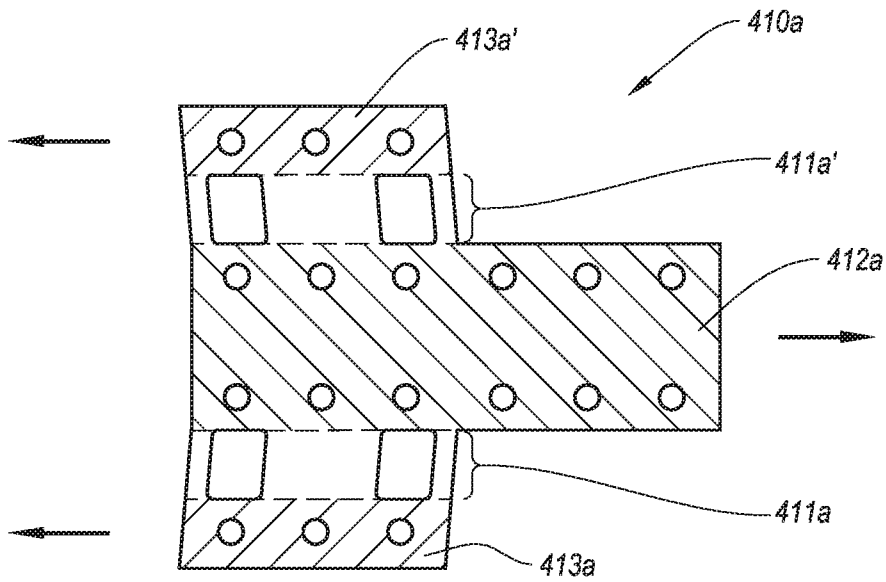

FIG. 4B

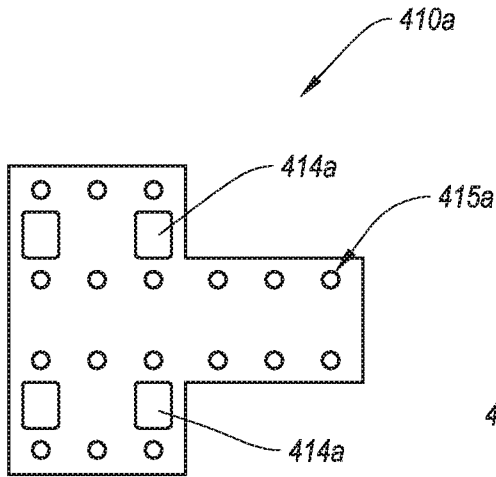

FIG. 5

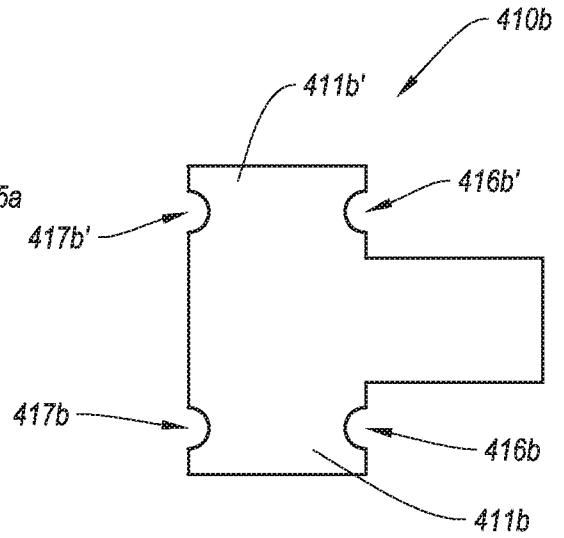

FIG. 6

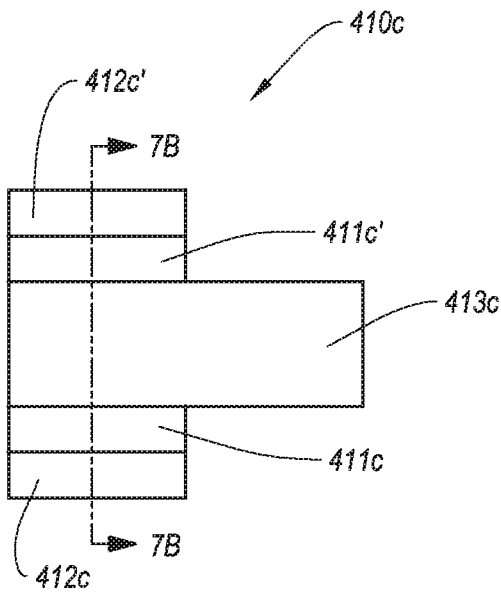

FIG. 7A

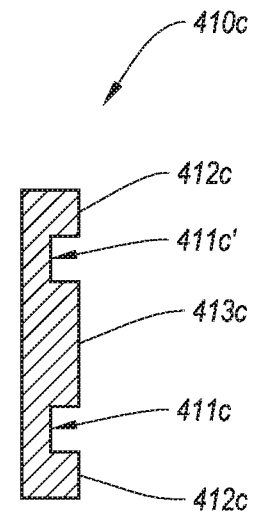

FIG. 7B

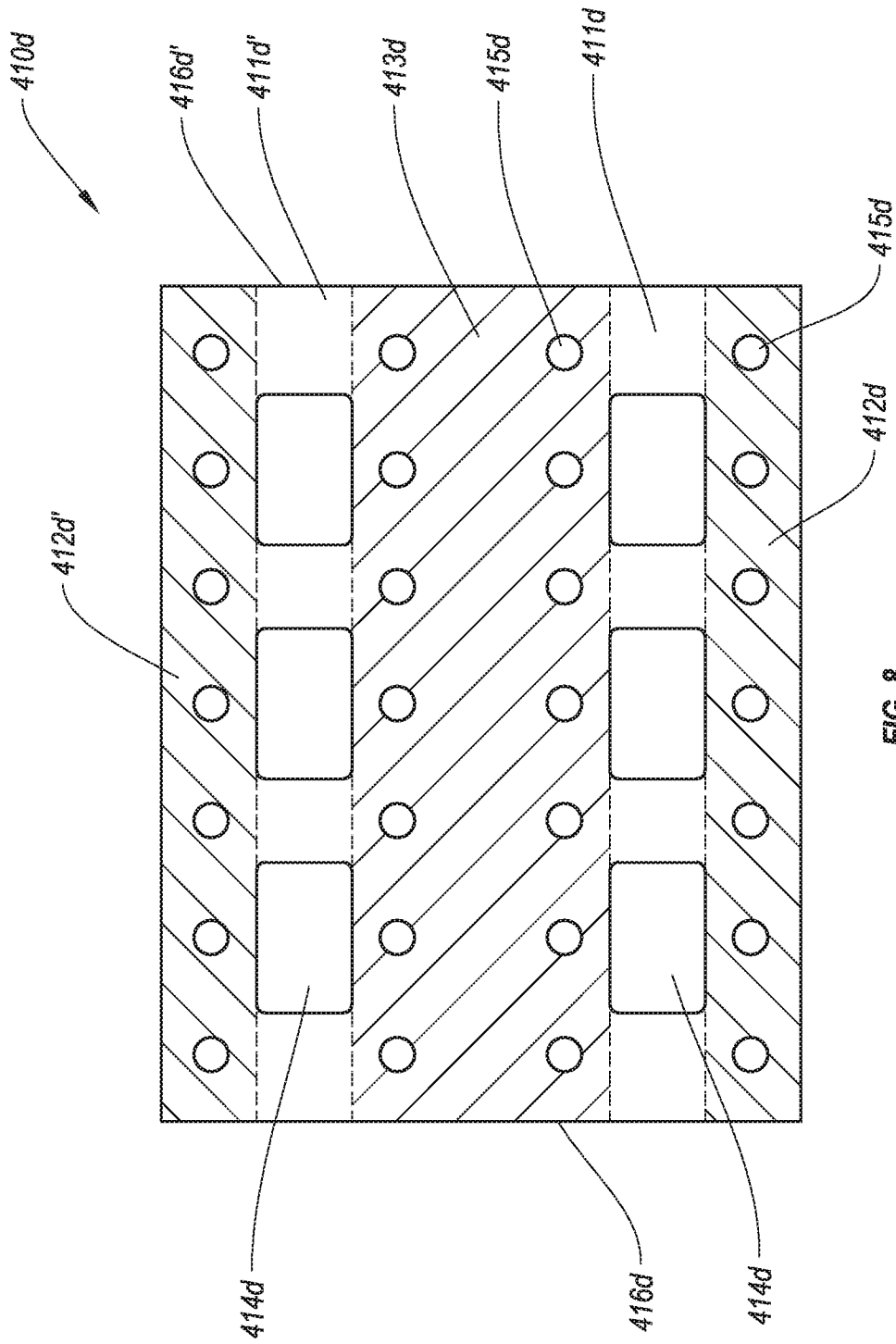

FIG. 8

