

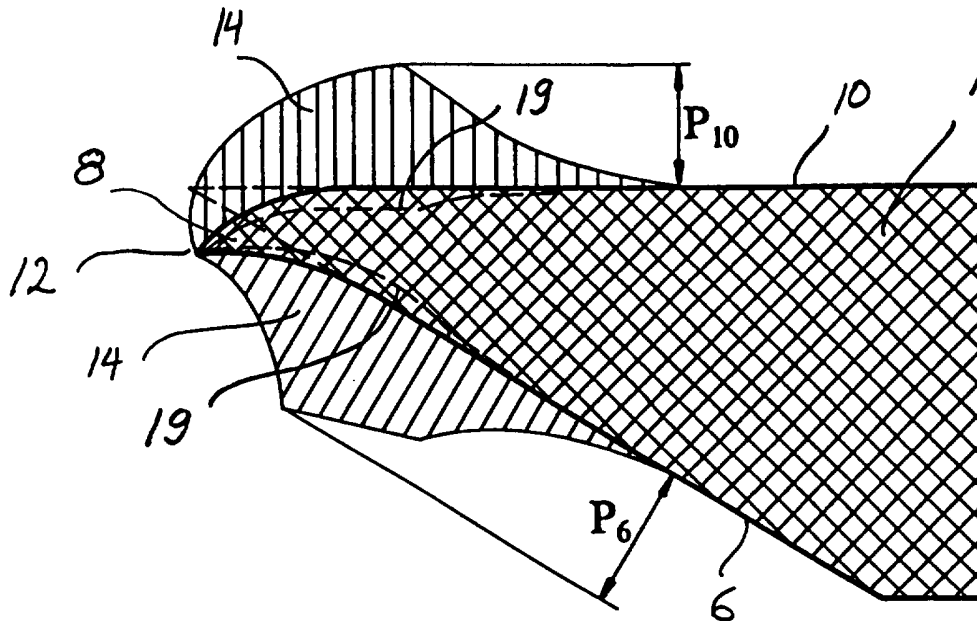

INTERNATIONAL APPLICATION PUBLISHED UNDER THE PATENT COOPERATION TREATY (PCT)

<p>(51) International Patent Classification⁶ : B27G 13/00</p>	<p>A1</p>	<p>(11) International Publication Number: WO 96/28287</p> <p>(43) International Publication Date: 19 September 1996 (19.09.96)</p>
<p>(21) International Application Number: PCT/FI95/00139</p> <p>(22) International Filing Date: 15 March 1995 (15.03.95)</p> <p>(71) Applicant (for all designated States except US): SUNDS DEFIBRATOR WOODHANDLING OY [FI/FI]; PI 210, FIN-28101 Pori (FI).</p> <p>(72) Inventors; and (75) Inventors/Applicants (for US only): JONKKA, Arvo [FI/FI]; Mäntykatu 20, FIN-28430 Pori (FI). TOHKALA, Antti [FI/FI]; Kourujärvenkatu 20, FIN-26660 Rauma (FI).</p> <p>(74) Agent: RUSKA & CO. OY; Runeberginkatu 5, FIN-00100 Helsinki (FI).</p>		<p>(81) Designated States: AU, BR, CA, NO, US, European patent (AT, BE, CH, DE, DK, ES, FR, GB, GR, IE, IT, LU, MC, NL, PT, SE).</p> <p>Published With international search report. In English translation (filed in Finnish).</p>

(54) Title: A METHOD OF INCREASING THE STRENGTH OF A BLADE, AND A BLADE



(57) Abstract

A method of increasing the durability of the cutting point (8) of a blade, and a blade. A compression stress (P_{10}) is formed in at least one surface (10 or 6) joining the point (8) of the blade (1) by cold working the blade.

FOR THE PURPOSES OF INFORMATION ONLY

Codes used to identify States party to the PCT on the front pages of pamphlets publishing international applications under the PCT.

AM	Armenia	GB	United Kingdom	MW	Malawi
AT	Austria	GE	Georgia	MX	Mexico
AU	Australia	GN	Guinea	NE	Niger
BB	Barbados	GR	Greece	NL	Netherlands
BE	Belgium	HU	Hungary	NO	Norway
BF	Burkina Faso	IE	Ireland	NZ	New Zealand
BG	Bulgaria	IT	Italy	PL	Poland
BJ	Benin	JP	Japan	PT	Portugal
BR	Brazil	KE	Kenya	RO	Romania
BY	Belarus	KG	Kyrgystan	RU	Russian Federation
CA	Canada	KP	Democratic People's Republic of Korea	SD	Sudan
CF	Central African Republic	KR	Republic of Korea	SE	Sweden
CG	Congo	KZ	Kazakhstan	SG	Singapore
CH	Switzerland	LI	Liechtenstein	SI	Slovenia
CI	Côte d'Ivoire	LK	Sri Lanka	SK	Slovakia
CM	Cameroon	LR	Liberia	SN	Senegal
CN	China	LT	Lithuania	SZ	Swaziland
CS	Czechoslovakia	LU	Luxembourg	TD	Chad
CZ	Czech Republic	LV	Latvia	TG	Togo
DE	Germany	MC	Monaco	TJ	Tajikistan
DK	Denmark	MD	Republic of Moldova	TT	Trinidad and Tobago
EE	Estonia	MG	Madagascar	UA	Ukraine
ES	Spain	ML	Mali	UG	Uganda
FI	Finland	MN	Mongolia	US	United States of America
FR	France	MR	Mauritania	UZ	Uzbekistan
GA	Gabon			VN	Viet Nam

A METHOD OF INCREASING THE STRENGTH OF A BLADE, AND A BLADE

This invention relates to a method of increasing the strength of the cutting point part of a blade. The invention also relates to a cutting blade.

5 The invention is primarily applicable to a sharp blade used for chipping wood and usually made of steel for cutting wood or other material so that the cutting force is applied to the point of the blade and forms a force wearing and breaking the point. For example, patent specification FI 79799 describes
10 a disc chipper provided with blades and used for chipping wood.

A problem with present blades is that blade durability requires a relatively big sharpening angle, and with an impact-like cutting process the hardness of the blade must be
15 limited so that the blade point will not scale.

Today the durability of the blade point very often limits the sharpening angle of the blade so that it is 34 - 35°, for example, in cellulose wood chipping. Blade hardnesses in a range of 56 - 60 HRC can hereby be used. A too sharp or too
20 hard blade point will scale during use. The blade point is nowadays made more durable by providing it with a counter-chamfer resulting in a point angle of 38 - 40° along a distance of about 2 mm from the point.

Blade point wear is a main problem with hard wood as blades
25 must be replaced when the chipper will not receive any more wood.

According to the theory of the strength of materials it is common knowledge that breakage will result when tensile stress exceeds a certain limit or repeated tensile stress peaks break
30 the material by fatiguing, whereby an initial crack leading to breakage will occur at a considerably lower level of tension.

A publication (Andreas Uhmeier) by Kungl. Tekniska Högskolan Stockholm 1993 deals with forces affecting the blade point
35 in wood chipping.

Shot-peening is a known method of cold working metal. Utilization of shot-peening is taught in the Peening Reference Manual (January 1991). Shot-peening is also the subject matter of Konepajamies (11/1992), a publication of the VTT.

The method according to the invention is characterized in that by cold working the blade, compression stress is formed in at least one blade surface forming the point. The blade according to the invention is characterized in that considerable compression stress exists on at least one blade surface forming the point.

An advantageous application of the method according to the invention is based on the fact that on that side of the blade point which detaches chips, compression stress is formed when manufacturing the blade, whereby the blade point bends towards the sharpening surface so that compression stress also results on the clearance side of the blade, which stress reduces quickly as the bent area ends. In connection with the manufacturing method according to the invention a very short shape also results which corresponds to the present counter-chamfer and which strengthens the blade point and on the other side of the point a "beak"-like blade point is formed, protruding from the sharpening surface and adding to the chipper's suction.

In the method according to the invention, compression stress is formed on the surfaces starting from the blade point on the part actively working the wood. At the same time a blade point results which increases chipper suction and after-sharpening may be performed on the point.

The invention and its details are described more closely in the following referring to the appended drawings, wherein the blade is shown in cross-section.

Figure 1 shows the way in which a chipper works when used for chipping pulp wood.

Figure 2 shows how a blade point penetrates into the wood.

Figure 3 shows the forces occurring in the blade point.

Figures 4 and 5 show the method of making a blade in accordance with the invention.

Figures 6, 7, 8 and 9 show states of stress in the blade point.

Figures 10 and 11 show shapes of a finished blade in accordance with the invention.

Figures 12 and 13 show an after-grinding method.

Figure 1 shows how a blade functions when used for chipping wood. Mounting of the blade 1 on a blade disk 15 is shown in Figure 13. Wearing plates 16 are mounted to the blade disk 15 and the blade 1 is locked in its position with a blade holder 17. Trees 2 to be chipped are guided by a chute 4 to slide against a blade disk, and blades 1 moving with the disk in direction S detach chip pieces 3. The blade 1 has a sharpening angle α at its cutting point, and the blade 1 is furthermore tilted so that a clearance angle β results between the sharpening surface 6 of the blade 1 and the cut surface of the chipped wood 2, which angle usually varies so that β is very small close to the blade disk shaft and big on the outer periphery of the blade disk. The thickness of the plate-like blade 1 is t and it is pressed in place from plate surfaces 10 and 21.

Figure 2 shows how wood grains 9 bend under the cutting force of the blade point 8. How much grains 9 will bend depends on the properties of wood 2 and on the sharpness of the point 8. As the wood grains 9 bent into a curved shape are cut off, the elastic force of the fibres will make them press against the sharpening surface 6 of the blade 1 as regards the surface indicated by a measure A. The surface 10 of the blade 1 detaches chip pieces 3, whereby a force detaching chip pieces results at the surface part indicated by a measure B.

Figure 3 shows force fields Q_A and Q_B occurring at the point 8 of the blade 1. The force field Q_A occurring in the sharpening surface 6 of the blade 1 prevents the tree 2 from sliding along the feeding ramp 4. The area indicated by the measure A becomes shorter as the angle β grows and hereby the force field Q_A will also be reduced. When the blade point 8 becomes dull, the yielding of tree grains 9 increases, whereby the measure A also grows adding to the force Q_A , whereby feeding of trees becomes difficult.

The width B of the force field Q_B affecting the surface of the blade 1 varies very much during chipping.

After the chip piece 3 has come off along a line 11, the force field Q_B is almost non-existent and the force pulling the tree 2 into the chipper or the so-called "suction power" is zero.

A case is then advantageous where wood is chipped simultaneously by two blades. This is often the case with a big tree or when chipping takes place close to the blade disk shaft.

At times during chipping, only a force Q_A according to Figure 3 is applied to the point 8 of the blade 1, whereby considerable tensile stress occurs in the surface 6 and there is a great risk of breakage in the point 8 of the blade 1. However, the area of influence of the force Q_A is quite narrow, and the measure A is 1 - 3 mm depending on the wood 2, on the sharpness of the point 8 of the blade 1 and on the suction angle β . In addition, the blade point 8 is subject to a force P which cuts off fibres 9 and gives a compression stress to the point of the blade 1 which plays no decisive part as regards the blade's durability.

The area B where the force is applied to the surface 10 of the blade 1 which detaches chips and the total force Q_B vary greatly and the force applied to the surface starting from the point 8 of the blade 1 also often in respect of the surface pressure exceeds the force applied to the surface 6 starting from the point 8. This results in forces occurring in the point of the blade 1 which will bend it in both directions.

It is a general notion that the blade 1 will work better when its sharpening angle α can be reduced. The suction angle β can then be increased which reduces the force Q_A opposing the feeding of trees, and in the same proportion it is also possible to reduce the suction force Q_B , the magnitude of which is proportional to damages to chip pieces 3.

With this invention it is hereby possible to considerably influence chip quality and chip production capacity. The smaller sharpening angle α' offers good possibilities of increasing the suction angle β without turning the blade 1 in relation to the blade disk.

With the method according to the invention, it is possible to make a durable blade 1, where the sharpening angle α of the point 8 is by 5 - 6° smaller than the one presently used.

Figure 4 shows a blade 1 from the point 8 of which extend a sharpening surface 6 and a chip detaching surface 10, and the sharpening angle α' between these is considerably smaller than with present blades. Presently the blade 1 is made more

durable by grinding a counter-chamfer into it as indicated by a dashed line 13.

Figure 5 shows treatment of the point of the blade 1 using a method according to the invention which is "shot-peening" and which is done after annealing and tempering of the blade 1. According to Figure 5, the surface 10 is subjected to peening with small grains or balls 20 having a diameter of 0.1 - 0.6 mm and hitting the surface at a speed of 50 - 150 m/sec in the way indicated by arrows V. Researches show that a compression film is hereby achieved in the steel sheet surface.

The thickness of the compression stress film is 0.1 - 0.6 mm, and the level of compression stress is 50 - 60 % of the yield strength of the material.

After shot-peening, the point of the blade 1 has bent in accordance with Figure 5, forming a bent point 8'. As the point 8 bends very far, the blade 1 cannot be used without after-grinding.

Figure 6 shows an after-ground blade 1, the surface 10 of which has been shot-peened and after-ground, while the point 8" has been ground in the direction of the sharpening surface 6 so that the level of the after-ground surface 6' is higher than the level of the sharpening surface 6 by a measure H_1 . An angle α'' becomes the angle of the cutting edge 12 of the point 8" of the blade 1, and it is considerably bigger than the original sharpening angle α' .

Figure 7 shows an alternative after-grinding method whereby the after-ground surface 6' joins the surface 6 smoothly and the cutting edge 12 of the point 8 of the blade exceeds the level of the surface 6 by a measure H_1 . Also in the blade 1 according to Figure 7, the angle α'' of the cutting edge 12 is considerably bigger than the sharpening angle α' . With the blades shown in Figures 6 and 7, the angle α'' of the cutting edge changes into the angle α' over a very small distance, which determines the blade properties. Using the method in accordance with the invention, it is hereby possible to make an "ideal" point 8 of the blade 1 where the angle α'' of the cutting edge 12 is usually 40 - 45°, but may even be 60°, that is, very strong and wear-resistant, and over a distance less

than 0.5 mm it turns into a very sharp sharpening angle α' . The main part of the difference between the angles α' and α is formed by the curved shape of the surface 10 in the point 8' of the blade 1, whereby the curve is usually $10^\circ - 15^\circ$, but may be $5 - 30^\circ$ in other applications.

The length of the after-ground surface 6 is less than 0.5 mm and by means of it, it is achieved a very short distance of influence A for the force field Q_A in accordance with Figures 2 and 3, because the point 8 of the blade 1 shown in Figures 6 and 7 in practice gives a great effect increasing the suction angle β which is due to the fact that the displacement of the cutting edge 12 by the measure H_1 changes into an "additional suction angle" in its entirety.

From this follows that blades 1, where the cutting edge 12 has been displaced from the sharpening surface 6 upwards by the measure H_1 , have a smaller force Q_A opposing the feeding of trees 2. The feeding of trees into the chipper is hereby improved and there is less risk of jamming of the chipper even with hard wood and with dull blades. The same result is achieved by increasing the suction angle β , but this will impair the durability of the point 8 of the blade 1 more than the very short "clearance" in the blade point given by the measure H_1 in accordance with Figures 6 and 7.

The main purpose of the invention is to increase the durability of the point 8 of the blade 1. As the blade point is affected by forces in both lateral directions according to the foregoing description, a thin compression stress zone must be obtained on surfaces 10 and 6 in the blade point.

The shot-peened blade 1 whose point 8 has bent as shown in Figures 5 and 8 achieves in its blade surfaces 6 and 10 the compression stress level shown schematically in Figure 8. The relative compression stress of the shot-peened surface is shown schematically by lines 14, the length of which represents the relative magnitude of the compression stress. The highest compression stress F_{10} is achieved through shot-peening at full power. Due to the bending of the point 8, the compression stress decreases towards the cutting edge 12 of the blade.

Compression stress occurs in the sharpening surface 6 because the blade point 8 bends, and partial upsetting of the material also occurs here. The compression stress peak P_6 in the surface 6 is higher than the compression stress P_{10} in the surface 10.

When after-grinding of the point 8 is performed on the blade 1, the compression stress levels will fall as shown in Figure 9, especially close to the blade edge 12. Also the surface's 6 highest compression stress $P'_6 \leq P_6$, and the surface's 10 highest compression stress $P'_{10} \leq P_{10}$. This partial release of the compression stress is advantageous because there is hereby more loading tolerance in view of the yield limit of the material.

Figure 10 shows the end of a blade 1 according to the invention, the point 8' of which is made in accordance with the present invention. Figure 11 shows the compression stress level in a section of the point 8'. The surface 10 has a compression stress P'_{10} which is almost constant 0.2 - 0.4 mm below the surface. The surface 6 has a compression stress P'_6 which below the surface falls linearly, and close to the centre of the cross-section achieves tensile stress V_{\max} . In Figures 8 and 9, a dashed line 19 shows the compression-tensile stress limit below the surface.

Figure 12 shows the blade point 8 in accordance with the invention after use, whereby the edge 12 has vanished and been replaced by a rounded point 8^R with a rounding radius R_8 . According to Figure 2, tree fibres slide over this point long before being cut off and they wear down the point more and more. This development can be interrupted by doing a second after-grinding of the point 8 of the blade 1, whereby the measure H_1 is reduced or the blade surface 6 is levelled out completely. After-grinding is possible due to the "beak"-like shape of the point 8 of the blade 1, and the said after-grinding comprises removal of 0.05 - 0.1 mm of material along a band 0.2 - 0.5 mm wide. The said work can be done without removing the blades from the chipper, and hereby the exchange interval for blades 1 can be almost doubled.

Figure 13 shows how the blade 1 is subjected to after-grinding while it is mounted to a blade disk 15. Using a

manually controlled grinder 18, a very small quantity of material is hereby removed from the blade point and a sharp cutting edge 12 is obtained for the blade. After-grinding is possible only with a blade according to the invention, because
5 the after-grinding surface 6' protruding from the sharpening surface 6 is very narrow. Everybody in the blade field knows that in practice it is too difficult to grind the whole sharpening surface 6 while the blade 1 is mounted to the blade disk 15.

10 The most usual way of making blades is by annealing and tempering blades 1 and by grinding the sharpening surface. However, grinding is a slow and expensive working method and forms a great part of blade manufacturing costs. By using the method in accordance with the invention, grinding of the
15 sharpening surface 6 before cold working can be eliminated when making a new blade, because adequate quality of the surface 6 is achieved by milling before annealing. After-grinding is hereby performed only after annealing and shot-peening. The whole sharpening surface 6 of the blade 1 is thus ground only
20 after use, so that the pre-grinding stage can be entirely eliminated for disposable blades.

Methods in accordance with the invention can be applied not only to chippers but also when such a point 8 of a blade 1 is needed which withstands varying loads and when a very big
25 clearance angle (suction angle β) immediately after the cutting edge 12 is useful when using the blade.

The method is also applicable for increasing durability, when the blade is one whose cutting edge has an angle of 90° . Tests show that in connection with shot-peening the hardness
30 of the peened surface increases by 1 - 2 HRC units with presently used blade materials and considerably more with other materials which will harden considerably in cold working. A better wear resistance is hereby obtained also for the blade point.

35 Shot-peening may also be replaced by some other cold working method creating a compression stress zone in the surface of the material. Such a method is, for example, rolling the surface with rollers and using a high surface pressure.

The principal field of application of the invention is wood chipper blades where by using the invention, blade durability and chip quality can be improved considerably. In addition, the invention brings savings in blade costs, blade exchange time, chipper auxiliary equipment (screens, chip cutters) and wood consumption.

In the above description and in the following claims the term blade point means the part in the longitudinal direction of the blade, located on both sides of the cutting edge. In the applications shown in the Figures, it is formed by the actual sharpening surface 6 and by the surface 10 detaching chips.

Claims

1. A method of increasing the durability of the cutting point part (8) of a blade (1) used for chipping wood so that a compression stress (P_{10}) is formed in the blade (1) surface (10) detaching chips, by cold working the blade by means of shot-peening or rolling, **characterized** in that when cold working the blade (1) surface (10) which detaches chips, its point part (8) bends towards the actual sharpening surface (6), whereby a compression stress (P_6) resulting from the bending occurs also in the sharpening surface (6).
2. A method as defined in claim 1, **characterized** in that after-grinding is performed on the point part (8) of the blade (1) bent towards the sharpening surface (6) so that an after-grinding surface (6') protrudes from the level of the actual sharpening surface (6).
3. A method as defined in claim 1 or 2, **characterized** in that the cutting edge (12") of the point part (8) of the blade (1) is made by bending the blade point part through shot-peening and after-grinding, so that a relatively large or $40 - 60^\circ$ edge (12") angle (α ") results which over a very short distance crosswise of the blade turns into a smaller sharpening angle (α or α') of the blade.
4. A method as defined in claim 2 or 3, **characterized** in that a second after-grinding is performed on the surface (6') protruding from the sharpening surface (6) of the point (8) of the blade (1), whereby the level of the surface (6') approaches or reaches the actual sharpening surface (6), and a cutting-edge (12) radius (R_g) resulting from wear is eliminated, whereby a new cutting edge (12') is formed in the blade point.
5. A method as defined in claim 4, **characterized** in that after-grinding of the blade (1) is done while it is in place in a device where (15) it is used.
6. A method as defined in any of claims 1 - 4, **characterized** in that machining of the sharpening surface (6) of a new blade (1) is completed before annealing, and after-grinding of the point (8) is done on the after-grinding surface (6') only after cold working.

7. A cutting blade (1) whose surface (10) detaching chips has a considerable compression stress (P_{10}) formed by shot-peening or rolling the blade's surface (10) which detaches chips, **characterized** in that shot-peening or rolling has bent the blade point part (8) towards the sharpening surface (6),
5 whereby a considerable compression stress (P_6) also results in the sharpening surface (6).

8. A blade as defined in claim 7, **characterized** in that after-grinding has been performed on the bent part of the point part (8) of the blade (1) so that the after-grinding surface (6') protrudes beyond the level of the actual grinding surface (6).
10

9. A blade as defined in claim 7 or 8, **characterized** in that the angle (α'') between the surfaces (10 and 6') of the point part (8) of the blade (1) which is made by shot-peening and after-grinding is considerably ($5 - 30^\circ$) bigger than the actual sharpening angle (α or α').
15

10. A blade as defined in claim 8 or 9, **characterized** in that the after-grinding surface (6') of the point (8) of the blade (1) is raised over a certain distance (H_1) from the actual blade surface (6) so that a considerable increase of the suction angle (β) results in the point part (8) of the blade (1).
20

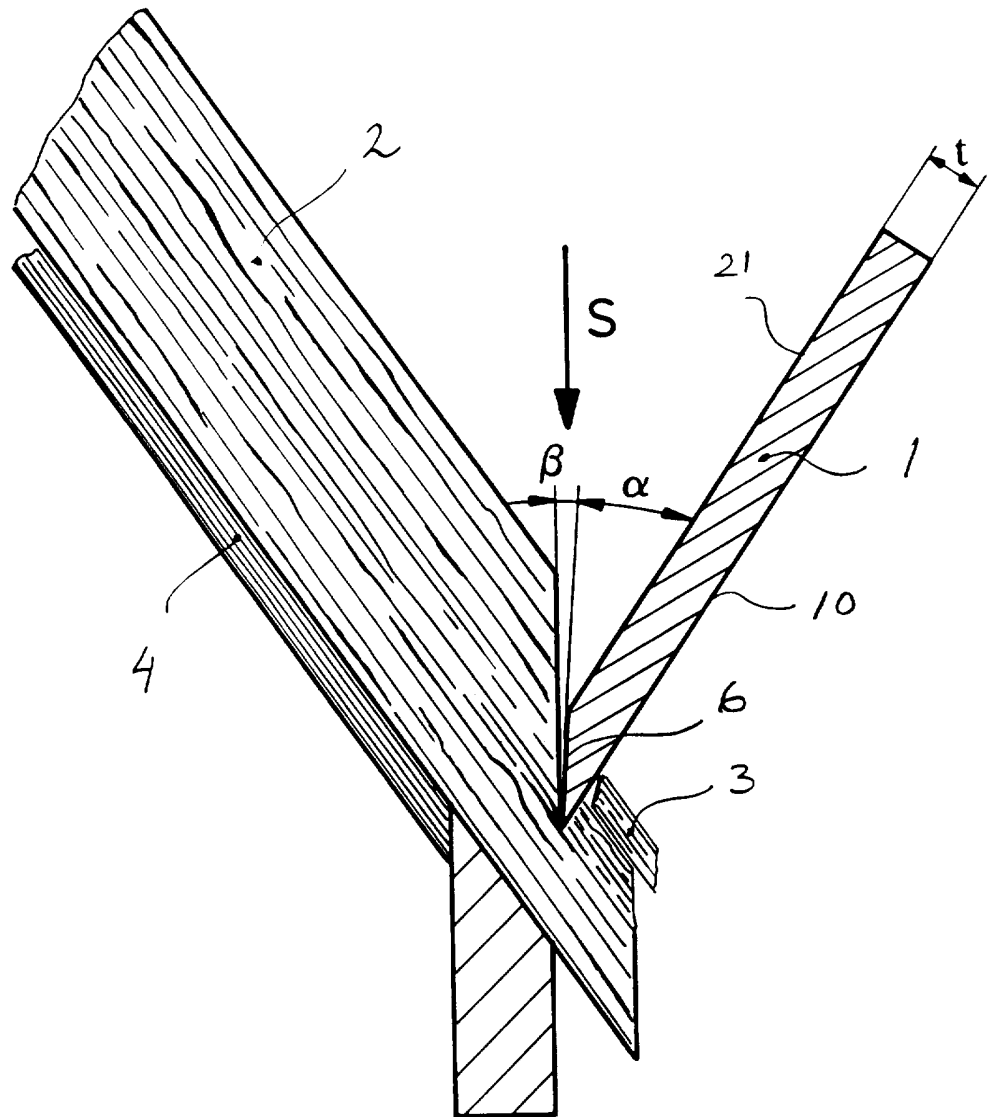

Fig. 1

2/8

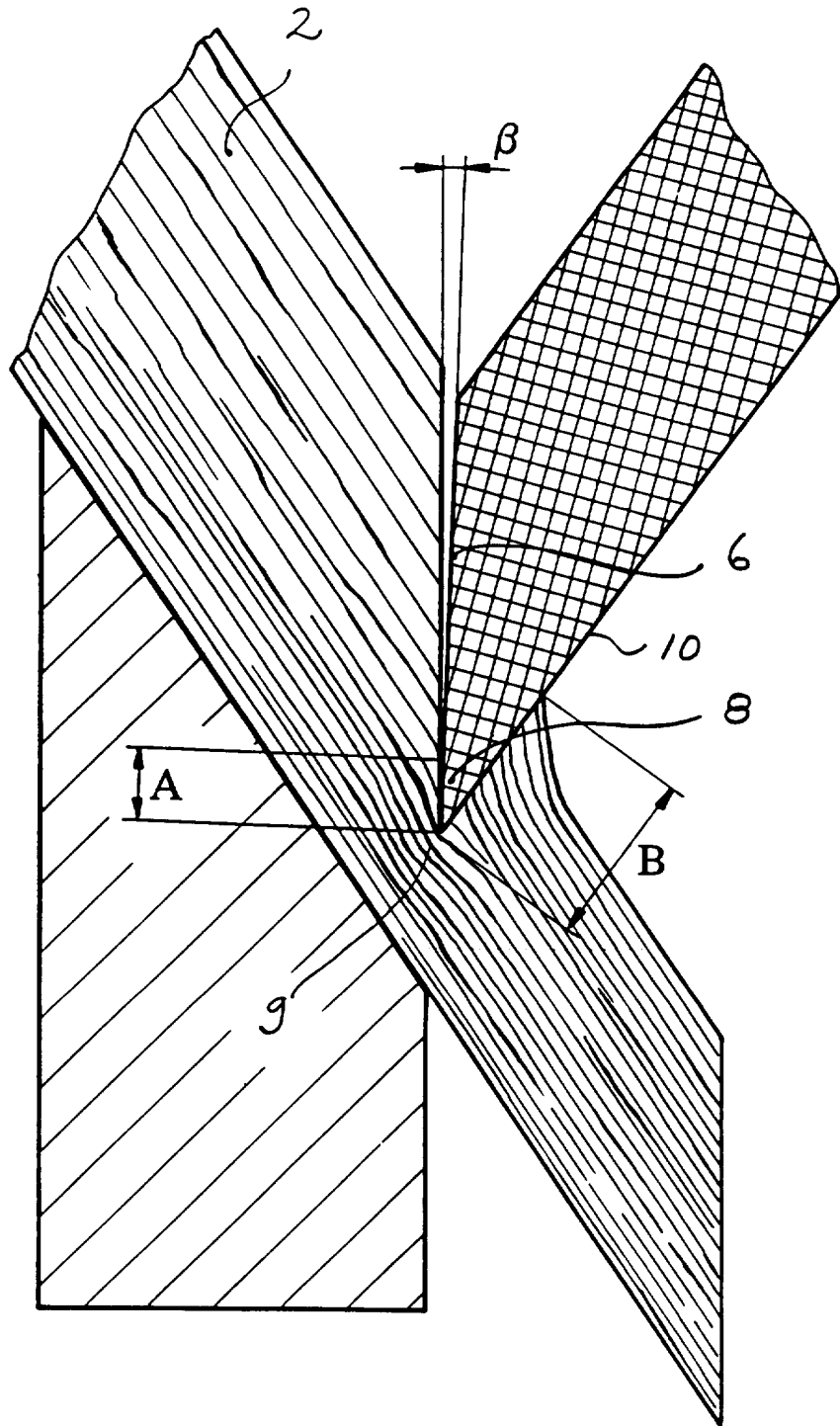

Fig. 2

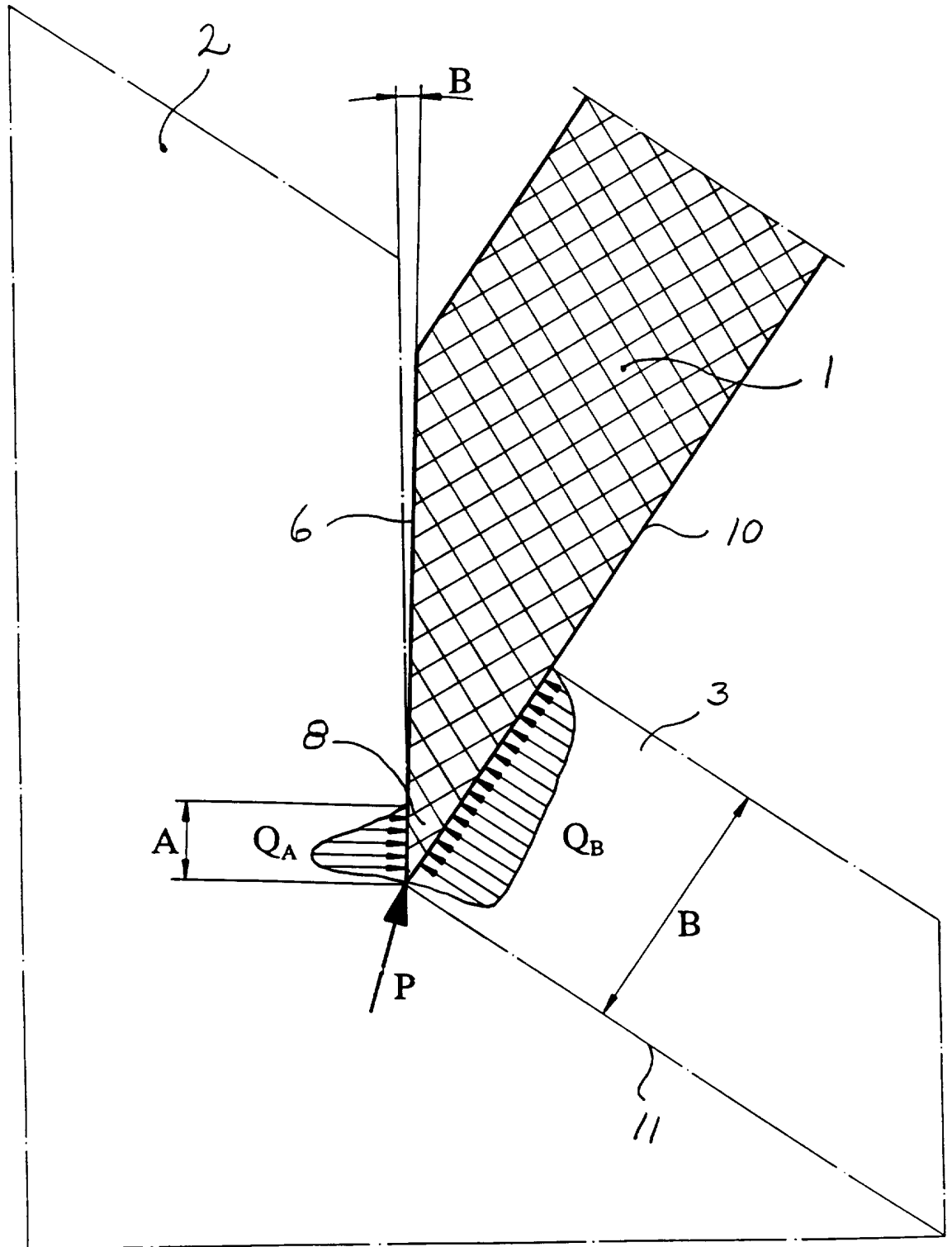

Fig. 3

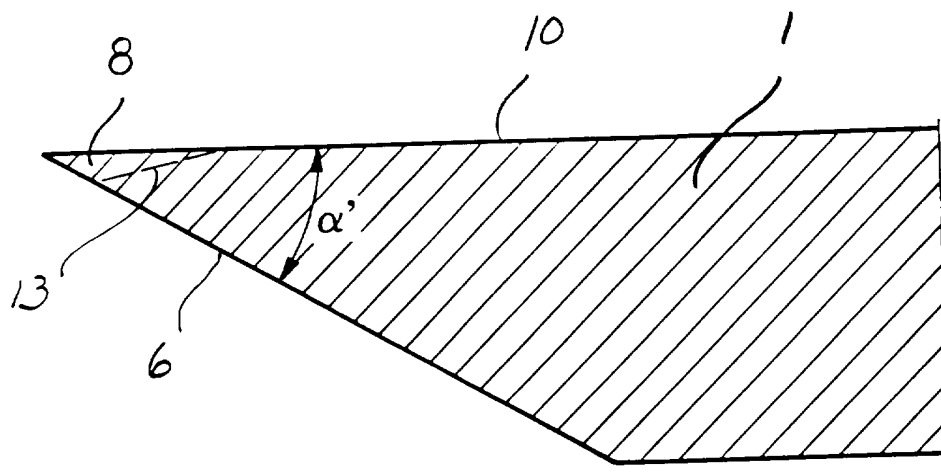

Fig. 4

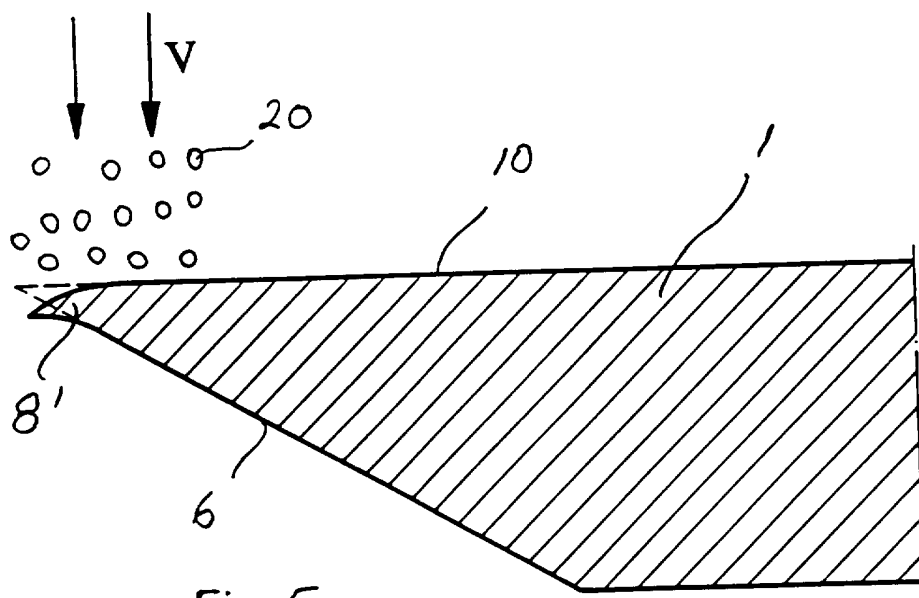

Fig. 5

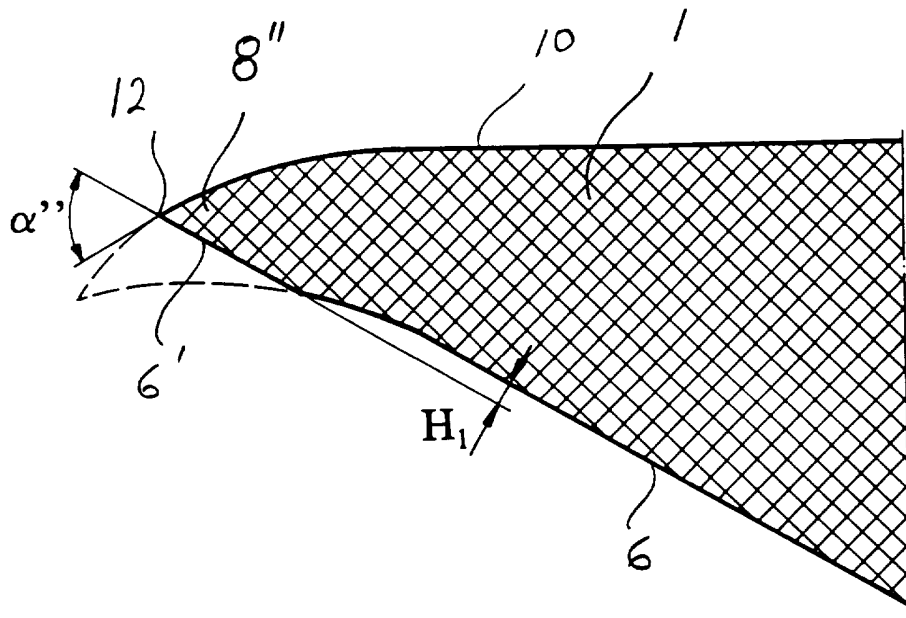

Fig. 6

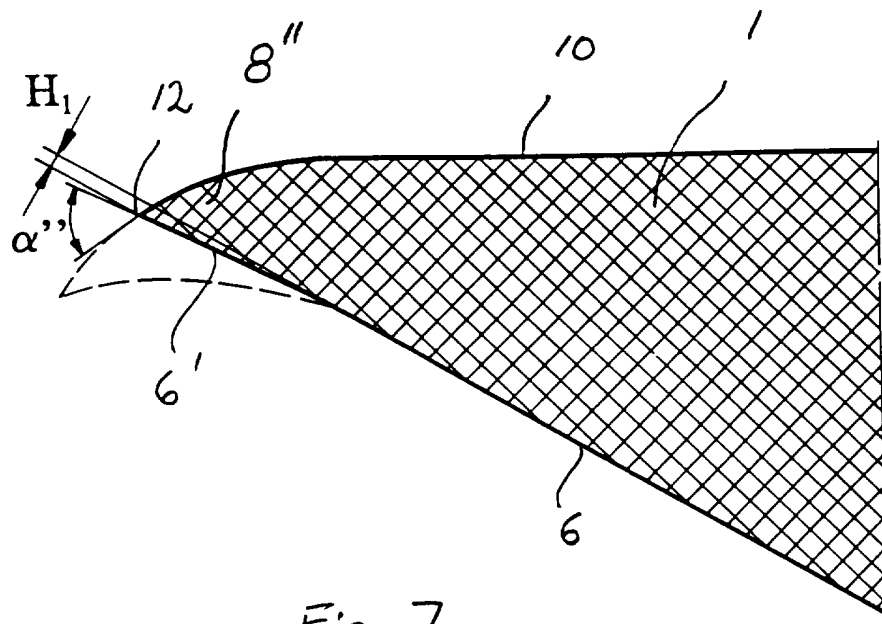

Fig. 7

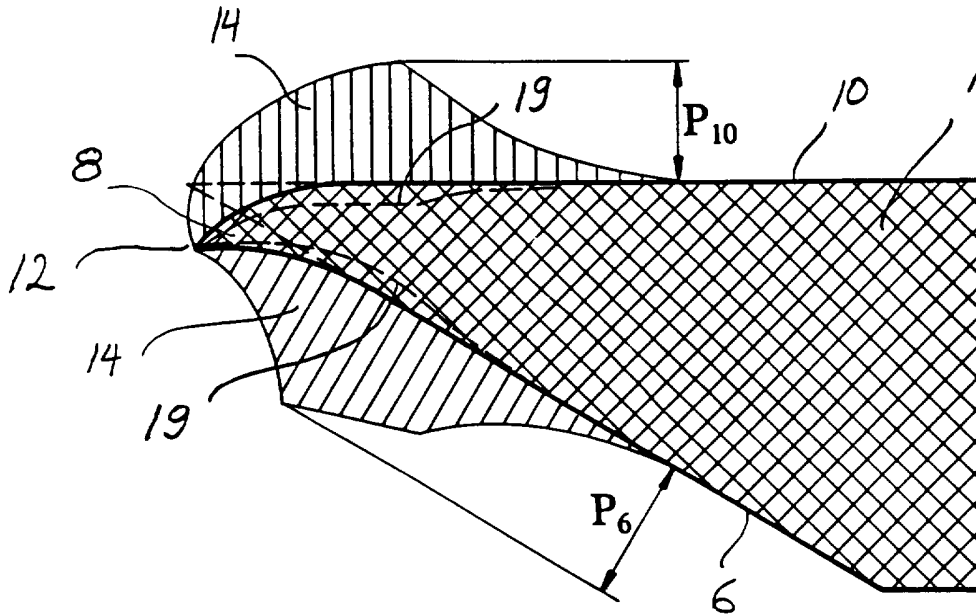

Fig. 8

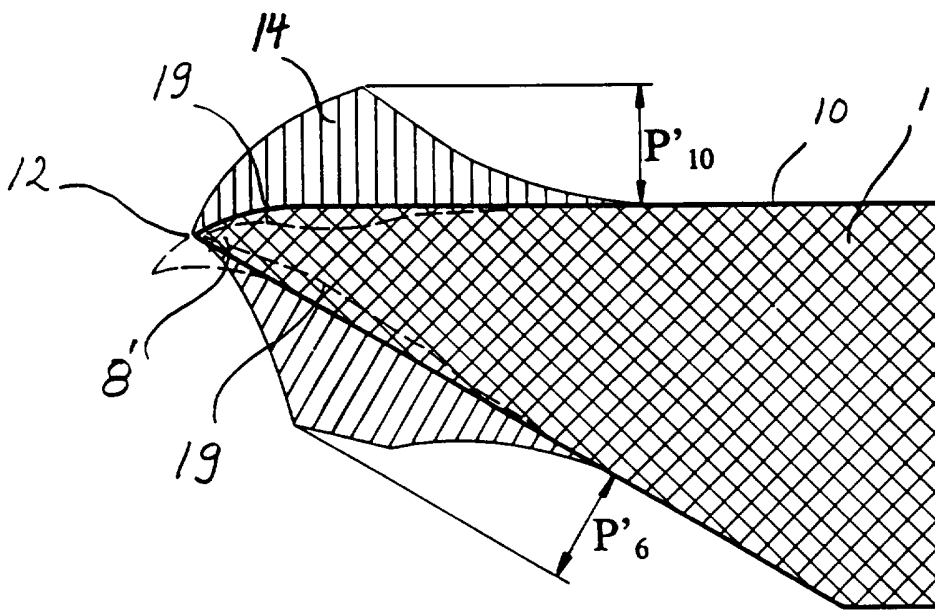

Fig. 9

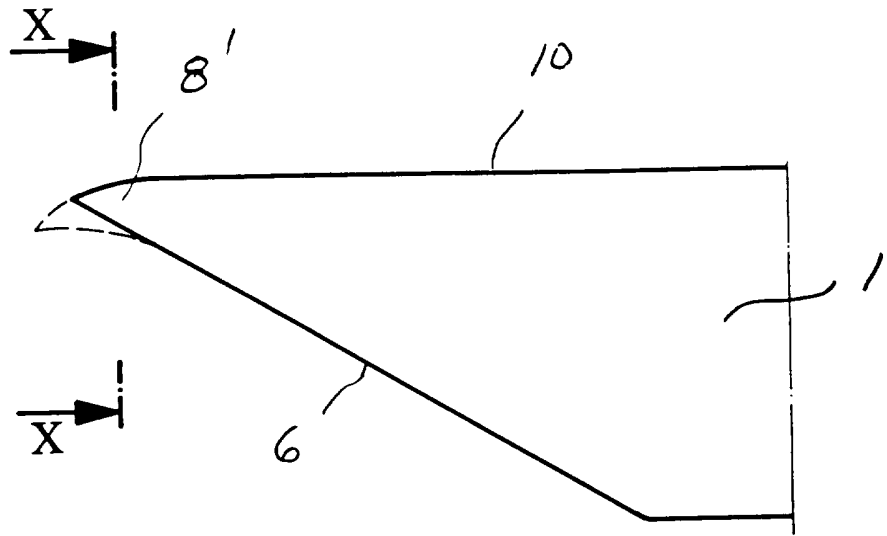

Fig. 10

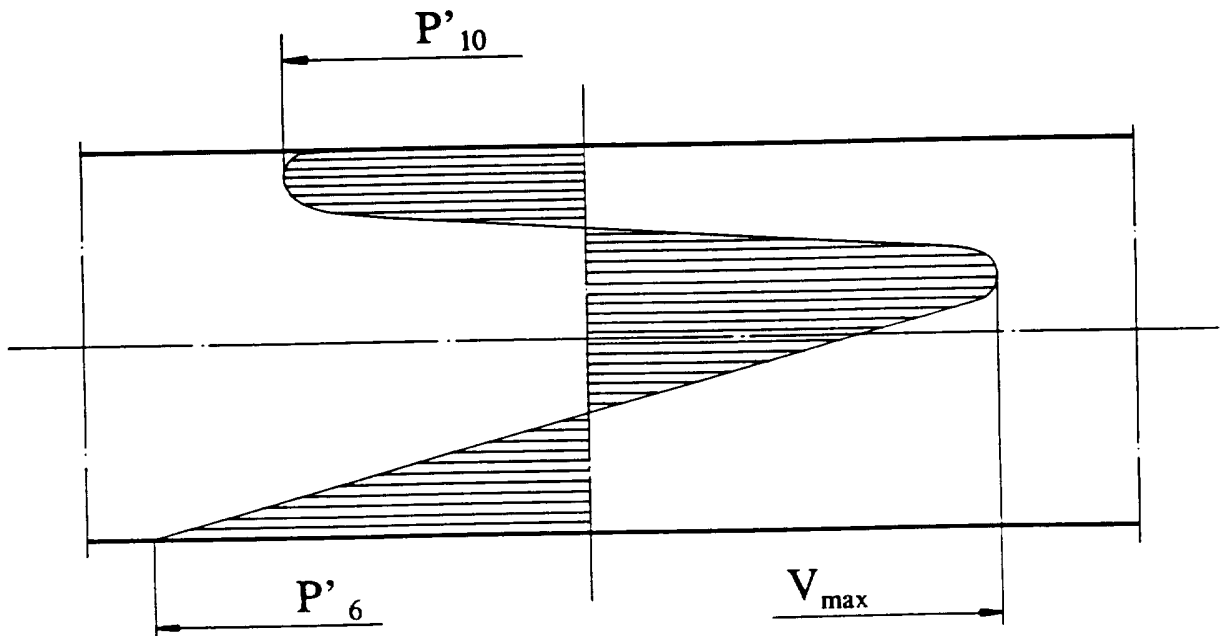
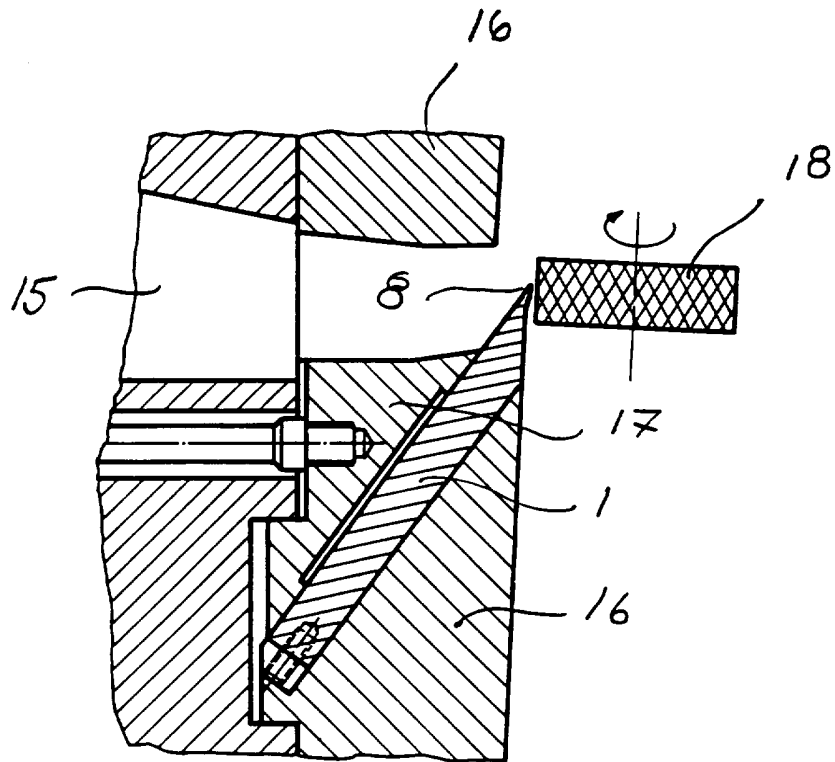
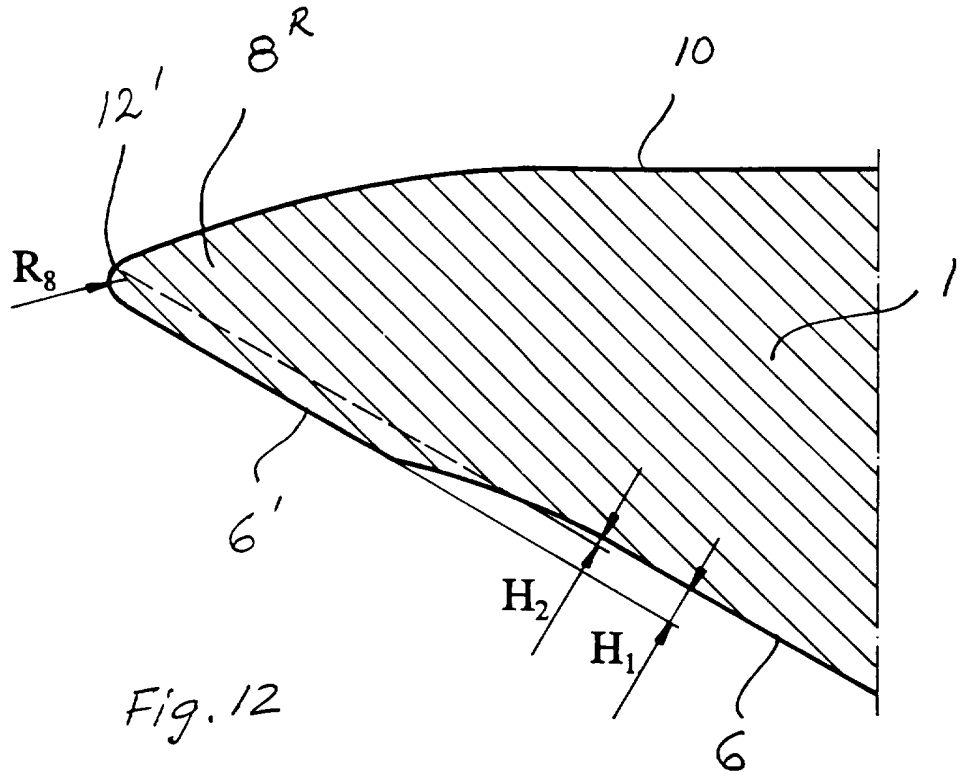

Fig. 11



INTERNATIONAL SEARCH REPORT

International application No.

PCT/FI 95/00139

A. CLASSIFICATION OF SUBJECT MATTER

IPC6: B27G 13/00

According to International Patent Classification (IPC) or to both national classification and IPC

B. FIELDS SEARCHED

Minimum documentation searched (classification system followed by classification symbols)

IPC6: B27L, B27G

Documentation searched other than minimum documentation to the extent that such documents are included in the fields searched

SE,DK,FI,NO classes as above

Electronic data base consulted during the international search (name of data base and, where practicable, search terms used)

QUESTEL

C. DOCUMENTS CONSIDERED TO BE RELEVANT

Category*	Citation of document, with indication, where appropriate, of the relevant passages	Relevant to claim No.
A	SE 459646 B (KARL-ERIK ARNOLD JONSSON), 24 July 1989 (24.07.89) --	1-10
A	WO 9015702 A1 (IGGESUND TOOLS AB), 27 December 1990 (27.12.90) --	1-10
A	US 4628976 A (LORING, DAVID A.), 16 December 1986 (16.12.86) --	1-10
A	US 4669516 A (CARPENTER ET AL.), 2 June 1987 (02.06.87) -- -----	1-10

 Further documents are listed in the continuation of Box C. See patent family annex.

* Special categories of cited documents:

"A" document defining the general state of the art which is not considered to be of particular relevance

"E" earlier document but published on or after the international filing date

"L" document which may throw doubts on priority claim(s) or which is cited to establish the publication date of another citation or other special reason (as specified)

"O" document referring to an oral disclosure, use, exhibition or other means

"P" document published prior to the international filing date but later than the priority date claimed

"I" later document published after the international filing date or priority date and not in conflict with the application but cited to understand the principle or theory underlying the invention

"X" document of particular relevance: the claimed invention cannot be considered novel or cannot be considered to involve an inventive step when the document is taken alone

"Y" document of particular relevance: the claimed invention cannot be considered to involve an inventive step when the document is taken alone, but it may be considered to involve an inventive step when the document is taken in combination with one or more other such documents, such combination being obvious to a person skilled in the art

"&" document member of the same patent family

Date of the actual completion of the international search

18 October 1995

Date of mailing of the international search report

09.11.1995

Name and mailing address of the ISA:

Swedish Patent Office

Box 5055, S-102 42 STOCKHOLM

Facsimile No. +46 8 666 02 86

Authorized officer

Eddy Leopold

Telephone No. +46 8 782 25 00

INTERNATIONAL SEARCH REPORT
Information on patent family members

02/10/95

International application No.
PCT/FI 95/00139

Patent document cited in search report	Publication date	Patent family member(s)	Publication date
SE-B- 459646	24/07/89	CA-A- 1280676 DE-A- 3728338 SE-A- 8603618 US-A- 4754789	26/02/91 03/03/88 28/02/88 05/07/88
WO-A1- 9015702	27/12/90	AU-A- 5937890 SE-B,C- 465118 SE-A- 8902290	08/01/91 29/07/91 23/12/90
US-A- 4628976	16/12/86	NONE	
US-A- 4669516	02/06/87	NONE	