

(19) **DANMARK**

(10) **DK/EP 2759652 T3**



Patent- og  
Varemærkestyrelsen

(12) **Oversættelse af  
europæisk patentskrift**

- 
- (51) Int.Cl.: **E 04 D 1/30 (2006.01)** **E 04 D 13/147 (2006.01)**
- (45) Oversættelsen bekendtgjort den: **2015-09-14**
- (80) Dato for Den Europæiske Patentmyndigheds bekendtgørelse om meddelelse af patentet: **2015-08-12**
- (86) Europæisk ansøgning nr.: **14150721.0**
- (86) Europæisk indleveringsdag: **2014-01-10**
- (87) Den europæiske ansøgnings publiceringsdag: **2014-07-30**
- (30) Prioritet: **2013-01-23 DE 102013100646**
- (84) Designerede stater: **AL AT BE BG CH CY CZ DE DK EE ES FI FR GB GR HR HU IE IS IT LI LT LU LV MC MK MT NL NO PL PT RO RS SE SI SK SM TR**
- (73) Patenthaver: **Monier Roofing Components GmbH, Frankfurter Landstrasse 2-4, 61440 Oberursel, Tyskland**
- (72) Opfinder: **Willen, Dirk, Schloßheide 25, 65366 Geisenheim, Tyskland  
Lindner, Falk, Königsberger Straße 87, 69502 Hemsbach, Tyskland  
Günther, Sven, Buchenstrasse 8, 59368 Werne, Tyskland  
Celebi, Yücel, Bahnstraße 12, 65366 Geisenheim, Tyskland**
- (74) Fuldmægtig i Danmark: **PLOUGMANN & VINGTOFT A/S, Rued Langgaards Vej 8, 2300 København S, Danmark**
- (54) Benævnelse: **TAGSTEN MED GENNEMGÅENDE ÅBNING**
- (56) Fremdragne publikationer:  
**EP-A1- 0 648 903  
DE-A1- 10 139 225  
DE-A1-102006 003 478  
DE-U1- 20 117 618**



The invention relates to a roof tile having a main body which comprises an opening, said opening being surrounded by a collar which comprises fastening elements on its side facing the opening, said fastening elements forming a fastening connection with counter fastening elements on an attachment which can be placed onto the opening.

DE 100 22 825 A1 discloses a roof tile having a main body which is made of plastics material and comprises an opening which is surrounded by a collar, onto which a dome of a ventilator dome can be placed.

DE 10 2006 003 478 A1 describes a tile having a through-hole, comprising an opening, the edge of which forms a collar, from the inner side of which fastening elements project, said fastening elements forming a fastening connection with counter fastening elements on an attachment part which can be placed onto the opening. Here, the collar is formed by an adapter having a circumferential flange which follows the contour of the roof tile. The adapter is connected to the main body by means of fixing elements or an adhesive.

DE 201 17 618 U1 describes a generic roof tile having a main body which comprises a circular opening in which a resilient rubber insert is arranged, said insert sealingly closing the opening around the edge, two supports, which are trapezoidal in the manner of an oval and form conical bushes, projecting from a membrane-like base layer having a false bearing.

DE 101 39 225 A1 describes a roofing sheet having a through-opening for a ventilation pipe. A cowl bearing the ventilation pipe sits in a pivotable manner on a dome which is formed integrally on and of the same material as a main body.

The object of the invention is to disclose a tile having a through-hole which is easy to produce and the collar of which can be connected to an attachment.

The object is achieved by the invention specified in the claims.

According to the invention, the collar comprises an inner part which is formed in particular by an annular part and is fastened to the main body by a fastening portion of the main body being placed on in a manner that follows the contours thereof. The fastening portion is

placed, in a contour-following manner, on the side of the inner part facing away from the opening. Here, the inner part forms at least one interlocking element which is interlocked with the fastening portion. The interlocking connection is formed during the production of the main body. For this purpose, the main body is moulded around the inner part in a thermoforming process. The inner part is an insert which is inserted into a corresponding recess in the thermoforming mould so that the plastics material forming the main body can be moulded around the outside of the inner part. The interlocking means is preferably a web, such as a circumferential web. This web has the shape of a rib which runs along the outside of the inner part. The fastening portion of the main body runs closely around this rib when the main body is thermoformed during the thermoforming process. Said portion thus forms an interlocking groove, in which the circumferential web engages. The insert has ventilation holes, in particular in the region of the interlocking means. These ventilation holes are aligned with ventilation holes in the thermoforming mould. During the thermoforming process, aeration takes place through the ventilation holes, allowing the material of the main body, which material is plastically deformable as a result of heating, to be positioned around the interlocking means. The fastening portion thus forms a thermoformed undercut by which the inner part is fastened to the main body with an interlocking fit and which also reinforces the collar. The thermoforming mould has recesses into which the latching lugs or latching tabs of the insert can engage. These latching tabs project into the free cross section of the opening and can engage in latch windows in an inner wall of a fastening flange on the attachment, said inner wall being inserted into the opening. In the process, an outer wall of the flange overlaps the collar so that the collar, and in particular also a sealing ring which surrounds the collar, lies inside an annular groove in the attachment. The fastening elements can be snap-on lugs or spring tabs, which can be displaced out of the cross section of the opening such that they can return resiliently, and which can deflect into latch windows. The thermoforming process is carried out using a non-perforated plastics blank. This blank is moulded over the insert. A water course and an overlay which are typical of roof tiles are formed. During the thermoforming process, preferably none of the undercuts of the thermoforming mould are engaged from behind. Only the circumferential web of the insert is engaged from below, with an interlocking fit, by the main body. However, this insert is removed from the mould during the mould removal stage so that the roof tile is easy to remove from the mould. After cooling, the insert enclosed with an interlocking fit is thus removed from the tool together with the tile having a through-hole. The edge and hole are then trimmed in the known processing stages. In a first variant of the invention, the inner part can be formed by a narrow annular part, which is overlapped in some regions by an edge

portion of the main body. The edge of the opening visible in a plan view is then formed by material of the main body. In a further variant, however, it is also provided that the inner part forms a dome, as described in DE 100 22 825 A1, on which the cowl of a roof vent can be placed. It is possible for the insert to be subsequently replaced if, for example, it is held in place with an interlocking fit by the attachment placed thereon. It is therefore easier for the roof tile to be recycled if the insert and main body are produced from the same materials. In the drawings:

Fig. 1 is a perspective view of a tile having a through-hole according to the invention, having a dome placed on top,

Fig. 2 is a section along the line II-II in Fig. 1,

Fig. 3 shows a thermoforming mould for producing the roof tile according to the invention,

Fig. 4 shows the thermoforming mould in accordance with Fig. 3 with the insert 10 inserted into the mould,

Fig. 5 is a follow-up drawing to Fig. 4 and shows the tile having a through-hole after the main body has been thermoformed, and

Fig. 6 shows the tile having a through-hole according to the invention after it has been removed from the mould.

The tile having a through-hole consists of a main body 1 which is produced in a thermoforming process. For this purpose, a thermoforming mould 30 (cf. Fig. 3, 4 and 5) is used which forms the negative mould of the underside of the tile having a through-hole. The thermoforming mould 30 has a mould portion 31 which protrudes with respect to the surrounding region of the mould and which forms an annular step 32, into which an insert 10 can be inserted. Since the insert 10 has undercut elements, the thermoforming mould 30 has recesses 33 which the undercut elements of the insert 10 can enter. The undercut elements are latching tabs 12.

The insert 10 is a ring made from plastics material. The insert 10 can be produced by means of injection moulding. In the embodiment the insert 10 is a narrow ring which appears oval

when viewed from above. The insert 10 delimits an opening 7 and forms a side facing the opening 7 and a side facing away from the opening 7. The insert 10 forms an annular web 11 along the side facing away from the opening 7, said web extending over the entire circumference of the insert 10.

Latching tabs 12 are found on the side facing the opening 7 and project into the cross section of the opening. The latching tabs 12 are resiliently outwardly bendable in the direction of the outside of the insert 10. The latching tabs 12 extend perpendicularly to a plane which is defined by the edge of the opening in the insert 10.

The insert 10 has ventilation holes 13 in the region of the annular web 11, said ventilation holes aligning with ventilation holes 34 in the thermoforming mould 30 when the insert 10 is inserted into an annular recess which is formed by an annular step 32 (cf. Fig. 4). In this state, the upper outer edge of the insert 10 is aligned with the planar end face of the mould portion 31.

At a temperature at which a blank which is made of plastics material and forms the main body 1 is plastically deformable, the blank which forms the main body 1 is thermoformed by means of the thermoforming mould 30 (cf. Fig. 5). The space between the underside of the blank and the thermoforming mould 30 is evacuated of air via ventilation holes and in particular via the ventilation hole 34 or 13 so that the thermo-ductile blank conforms to the surface contour of the thermoforming mould 30 and the surface contour of the annular part 10 inserted into the thermoforming mould 30. In doing so, the blank of the main body 1 shapes the opening clearance in the insert 10 and forms a negative undercut in the shape of an interlocking groove 5 in the region of the annular web 11. This undercut, that is to say the interlocking groove 5, is preferably the only undercut formed during the thermoforming process.

After cooling, the main body 1 and the insert 10 which is enclosed thereby with an interlocking fit are removed from the mould. Then, the edge and the opening 7 are trimmed so that an opening edge 6 of the main body 1 surrounds the opening 7. Fig. 6 shows the completed tile having a through-hole, without an attachment placed on top. Fig. 1 shows a tile having a through-hole, with a dome placed on top. The cross section of the entire collar can be seen in the section shown in Fig. 2. In the embodiment, the opening edge 6 rests on

the upper outer edge of the insert 10. The insert 10 forms a collar which follows the edge of the opening 7.

An attachment 20 can be placed on this collar 10. The attachment 20 may be a ventilating fan, a bushing for cables or pipes, or any other unit which can be fitted to a roof.

The attachment 20 shown in Fig. 1 and 2 is a dome 25 in which a ventilation pipe having a cowl can be inserted. The dome 25 is integrally formed on the underside of a fastening flange 26. The fastening flange 26 has an inner web 23 which can be inserted into the opening 7. In this case, the inner web 23 is positioned on the inner wall of the insert 10. The inner web 23 has windows 24 into which the latching tabs 12 of the insert 10 can latch in order to connect the attachment 20 to the tile having a through-hole.

The fastening flange 26 overlays the collar and in particular overlays the opening edge 6, a portion of the main body 1, and the portion, connected thereto, of the insert 10. This collar is thus overlaid by a wall 22 of the fastening flange 26. The collar is positioned in an annular groove 21 formed by the wall 22 and the inner web 23.

A sealing ring 27 which surrounds the outer wall of the collar 10 is also positioned in the annular groove 21. The sealing ring 27 is positioned between a portion of the main body 1 and the wall 22.

The downward facing edge of the wall 22 of the fastening flange 26 can rest on the outer wall of the region of the fastening portion 4 which forms the interlocking groove 5. This forms a watertight region between the attachment 20 and the main body 1 because the fastening portion 4 engages in the annular groove 21 and is made watertight with a sealing ring 27.

Different kinds of attachments 20 can be connected to an insert 10 which is formed as a standard element.

The aforementioned embodiments are used to explain the invention which independently improves the prior art at least by means of the following combinations of features, namely:

A tile having a through-hole according to claim 1, which is characterised in that the collar comprises an inner part 10 which is in particular produced from plastics material and is

fastened to the main body 1 by a fastening portion 4 of the main body 1 being placed on the side of the collar facing away from the opening 7 so as to follow the contours thereof at least in some regions.

A tile having a through-hole according to claim 1, which is characterised in that the main body 1 is a thermoformed, in particular deep-drawn, plastics body.

A tile having a through-hole according to claim 1, which is characterised in that the side of the inner part 10 which faces away from the opening 7 forms at least one interlocking element 11 which is in an interlocking connection 5 with the fastening portion 4.

A tile having a through-hole according to claim 1, which is characterised in that the interlocking means on the in particular annular inner part is a web 11, in particular a circumferential web, which is positioned in an interlocking groove 5 in the main body 1.

A tile having a through-hole according to claim 1, which is characterised in that the fastening elements 12 project into the cross section of the opening 7.

A tile having a through-hole according to claim 1, which is characterised in that the fastening elements 12 can be displaced out of the cross section of the opening such that they can return resiliently.

A tile having a through-hole according to claim 1, which is characterised in that the fastening elements 12 form snap-on lugs or spring tabs which latch into latch openings 24 in the attachment 20.

A tile having a through-hole according to claim 1, which is characterised in that the inner part 10 is formed by an insert which is inserted into a thermoforming mould 30 before the main body 1 is thermoformed and over which the main body 1 is thermoformed.

A tile having a through-hole according to claim 1, which is characterised in that the roof tile comprises an attachment 20 which is in the form of a dome 25, a ventilation element, a bushing for cables or a bushing for aerials, and which comprises counter fastening elements 24 which are connected to the fastening elements 12.

All the disclosed features are essential to the invention (separately and also in combination with one another). The features of the dependent claims characterise independent inventive developments of the prior art.

**List of reference numerals**

- 1 Main body
- 2 Overlay
- 3 Water course
- 4 Fastening portion
- 5 Interlocking groove
- 6 Edge of the opening
- 7 Opening
- 10 Insert, annular part, inner part, collar
- 11 Annular web, interlocking element
- 12 Latching tab, fastening elements
- 13 Ventilation hole
- 20 Attachment
- 21 Annular groove
- 22 Wall
- 23 Inner web
- 24 Window, counter fastening elements, latch openings
- 25 Dome
- 26 Fastening flange
- 27 Sealing ring
- 30 Thermoforming mould
- 31 Mould portion for the opening
- 32 Annular step
- 33 Recess for the annular step
- 34 Ventilation hole

**Patentkrav**

1. Tagsten med gennemgående åbning, omfattende et hovedlegeme (1) bestående af et plastmateriale og en åbning (7) omgivet af en krave (10), som på den side, der vender mod åbningen (7), har fastgørelseselementer (12), som er i stand til at danne en fast forbindelse med modfastgørelseselementer (24) på et påbygningselement (20) der kan sættes på åbningen (7), hvor kraven omfatter en indre del (10), der især er fremstillet af plastmateriale og på sin side, der vender væk fra åbningen (7), danner mindst et formluttende forbindelseselement, **kendetegnet ved at** den indre del (10) er dannet som en indlægningsdel til indlægning i en dybtrækningsform, og det formluttende forbindelseselement er fastgjort til et fastgørelsesafsnit (4) på hovedlegemet (1) ved dybtrækning af hovedlegemet (1) over den indre del (10) i det mindste områdevist i konturfølgende anlæg.
2. Tagsten med gennemgående åbning ifølge krav 1, **kendetegnet ved at** hovedlegemet (1) er et termoformet plastlegeme.
3. Tagsten med gennemgående åbning ifølge et hvilket som helst af de foregående krav, **kendetegnet ved at** formluttende forbindelsesorganer på den især ringformede indre del er en bane (11), især en periferisk bane, der er positioneret i en formluttende rille (5) i hovedlegemet (1).
4. Tagsten med gennemgående åbning ifølge et hvilket som helst af de foregående krav, **kendetegnet ved at** fastgørelseselementerne (12) rager ind i tværsnittet af åbningen (7).
5. Tagsten med gennemgående åbning ifølge et hvilket som helst af de foregående krav, **kendetegnet ved at** fastgørelseselementerne (12) kan forskydes ud at åbningens tværsnit og kan returnere elastisk.
6. Tagsten med gennemgående åbning ifølge et hvilket som helst af de foregående krav, **kendetegnet ved at** fastgørelseselementerne (12) danner snapkanter eller elastiske flige som snaplåser ind i låseåbninger (24) i påbygningselementet (20).

- 7.** Tagsten med gennemgående åbning ifølge et hvilket som helst af de foregående krav, **kendetegnet ved at** tagstenen omfatter et påbygningselement (20) der er i form af en kuppel (25), et ventilationselement, en
- 5 kabelgennemføring eller en antennegennemføring, og som omfatter modfastgørelseselementer (24) der er forbundet til fastgørelseselementerne (12).
- 8.** Tagsten med gennemgående åbning ifølge et hvilket som helst af de foregående krav, **kendetegnet ved at** den indre del (10) og fastgørelsesdelen
- 10 (4) danner to lag af en studsformet krave (10), hvilke to lag kun kan adskilles fra hinanden på en destruktiv måde.

**Fig. 1**

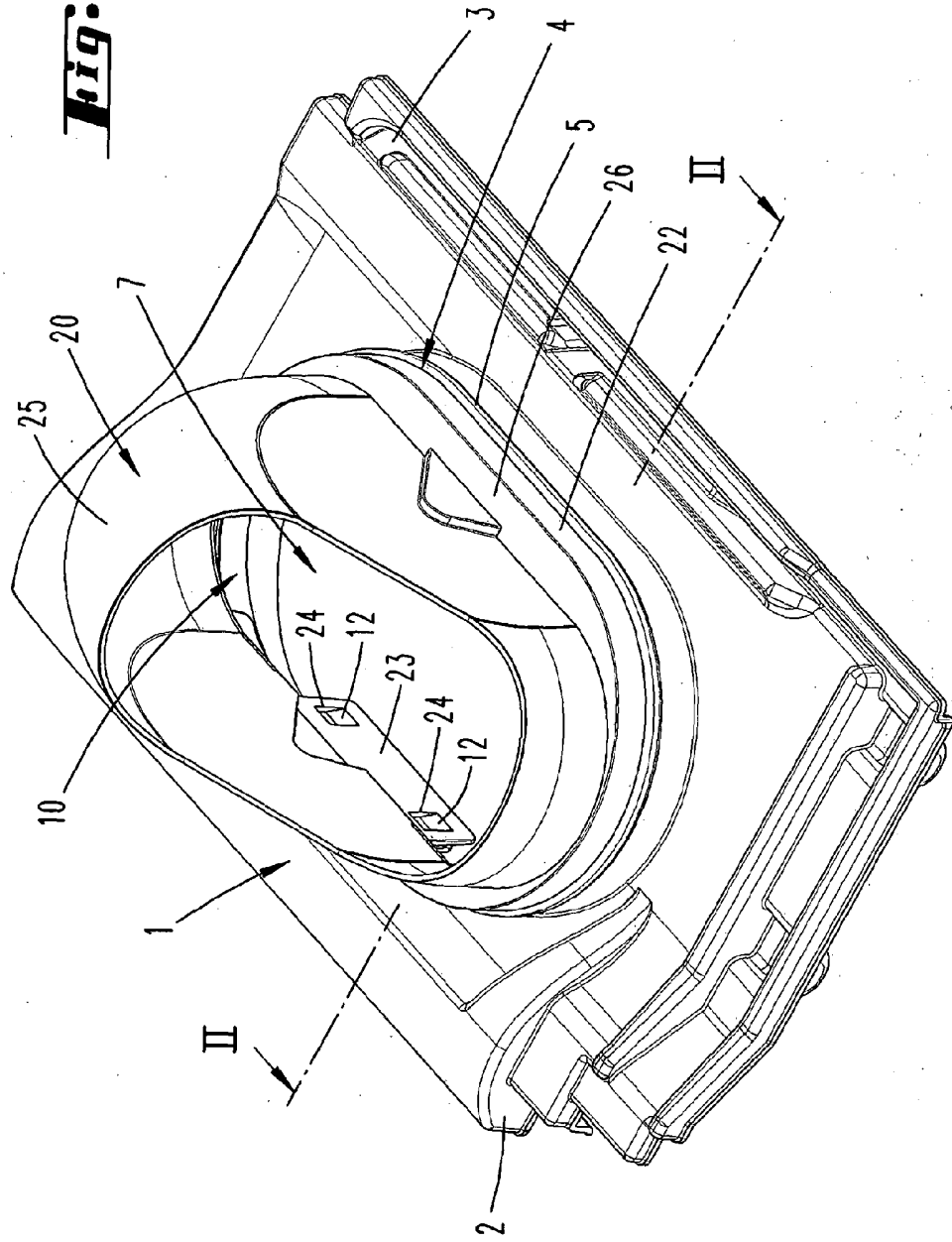

2/6

**Fig. 2**

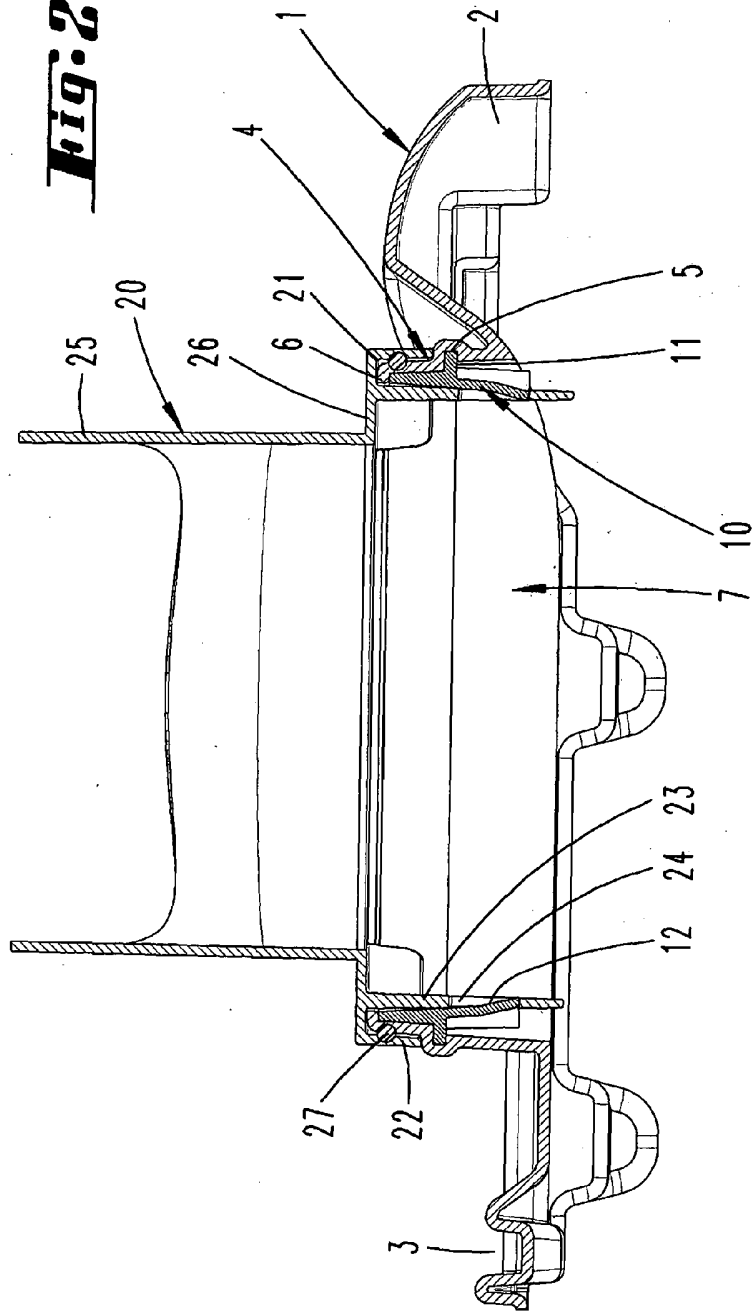

3/6

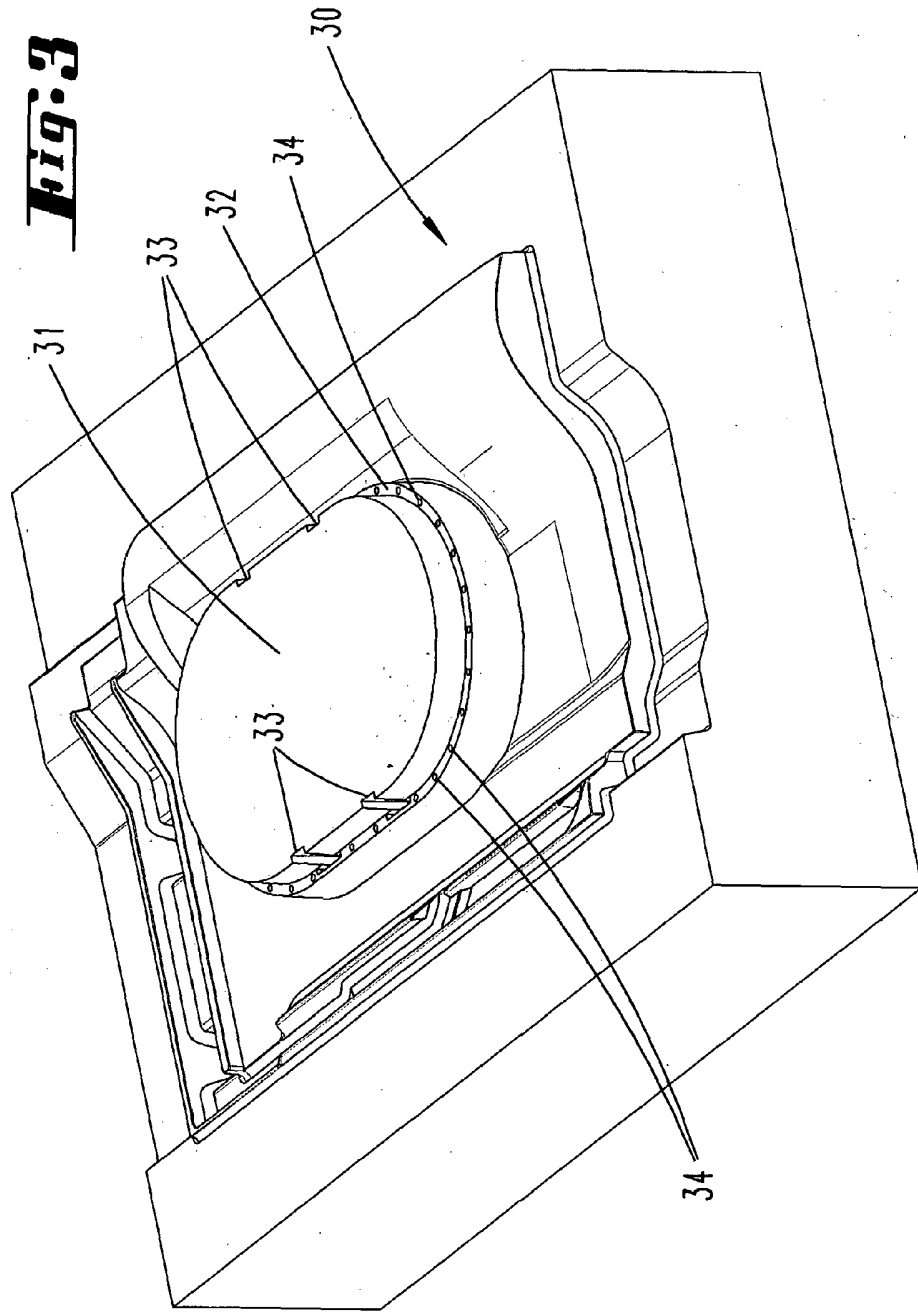

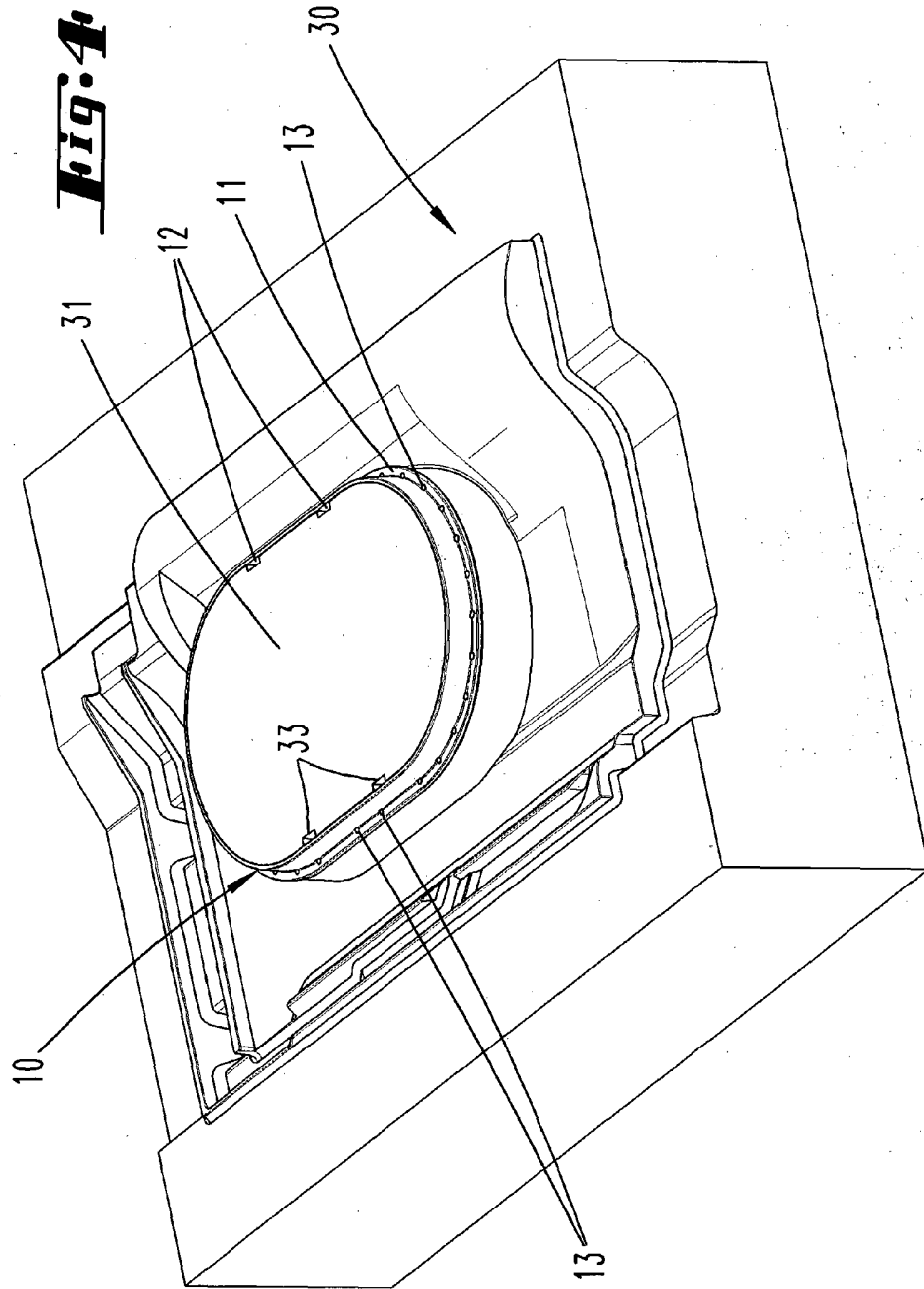

5/6

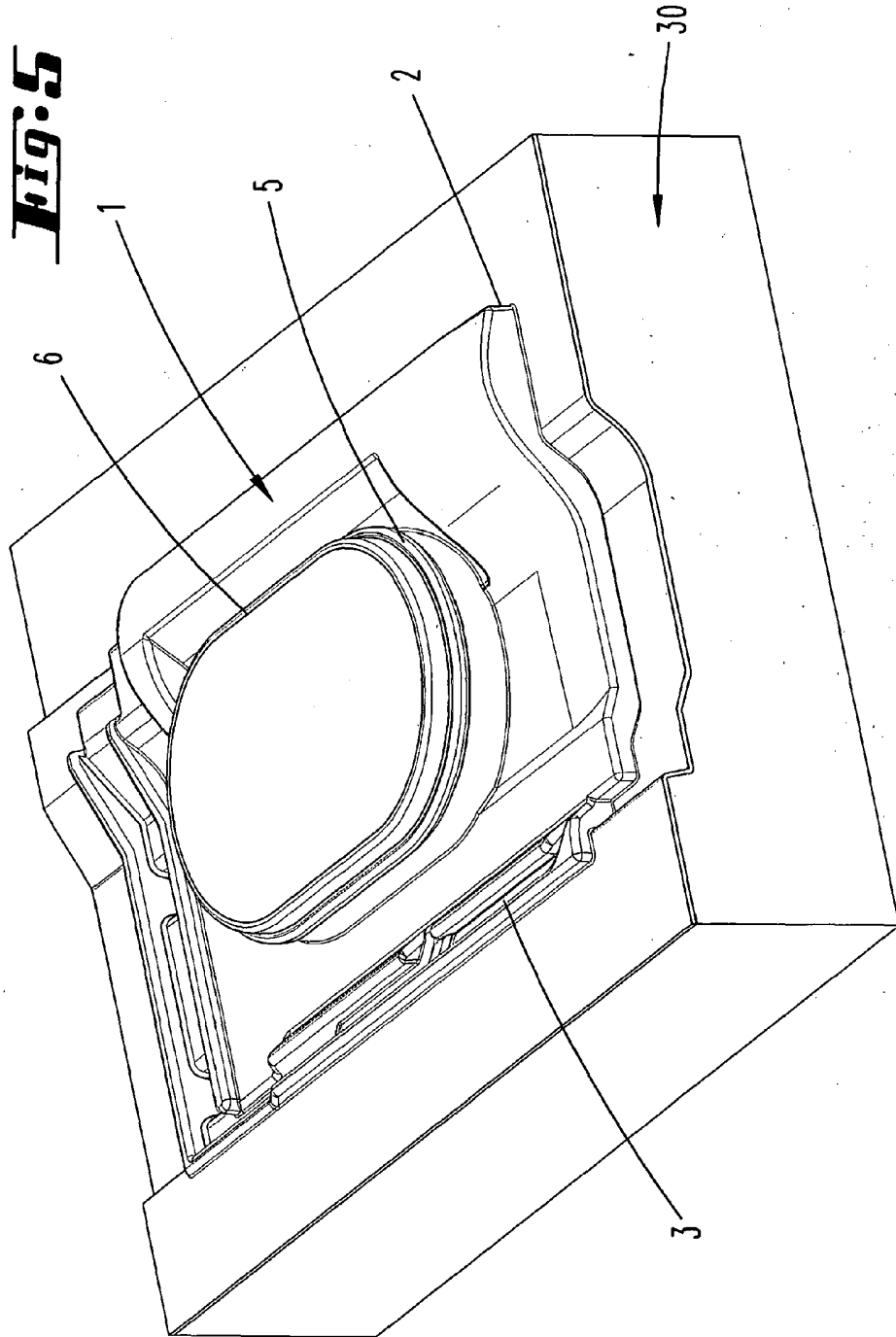

**Fig. 6**

