

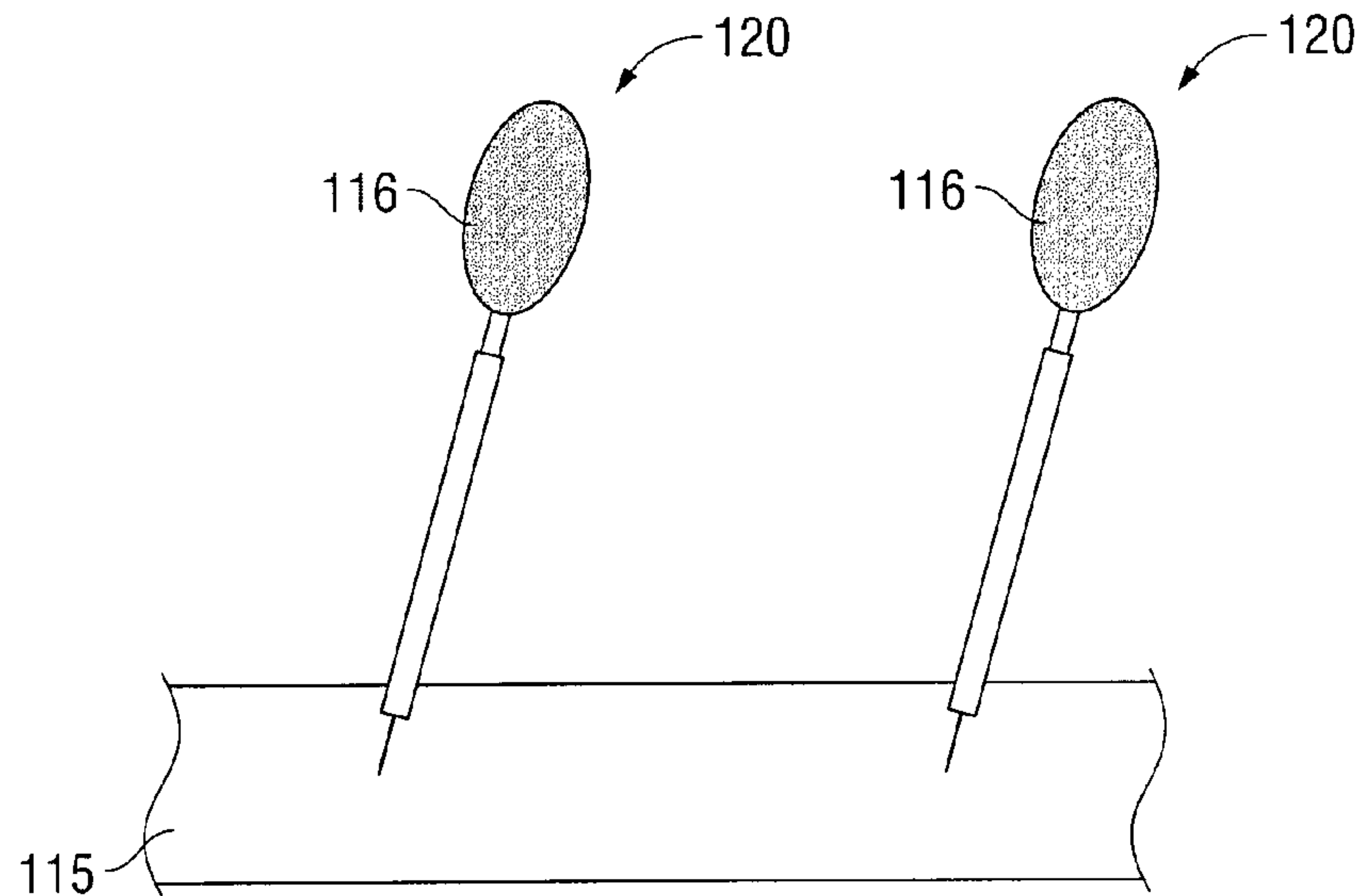

(86) Date de dépôt PCT/PCT Filing Date: 2011/07/25  
(87) Date publication PCT/PCT Publication Date: 2012/02/02  
(45) Date de délivrance/Issue Date: 2019/04/09  
(85) Entrée phase nationale/National Entry: 2013/01/18  
(86) N° demande PCT/PCT Application No.: IB 2011/002429  
(87) N° publication PCT/PCT Publication No.: 2012/014080  
(30) Priorité/Priority: 2010/07/27 (US61/367,964)

(51) Cl.Int./Int.Cl. *A61L 17/00* (2006.01),  
*C08J 7/12* (2006.01), *D01F 11/14* (2006.01)  
(72) Inventeur/Inventor:  
LADET, SEBASTIEN, FR  
(73) Propriétaire/Owner:  
SOFRADIM PRODUCTION, FR  
(74) Agent: OSLER, HOSKIN & HARCOURT LLP

(54) Titre : FIBRES POLYMERES AYANT DES ELEMENTS REACTIFS AUX TISSUS  
(54) Title: POLYMERIC FIBERS HAVING TISSUE REACTIVE MEMBERS



(57) Abrégé/Abstract:

A method for bonding a polymeric fiber to tissue is provided which includes providing a polymeric fiber having a plurality of tissue reactive members linked to a surface of the fiber via a specific binding pair, and contacting the polymeric fiber to biological tissue, to covalently bond the fiber to the tissue.

(12) INTERNATIONAL APPLICATION PUBLISHED UNDER THE PATENT COOPERATION TREATY (PCT)

(19) World Intellectual Property  
Organization  
International Bureau

WIPO | PCT

(10) International Publication Number  
**WO 2012/014080 A3**(43) International Publication Date  
2 February 2012 (02.02.2012)

## (51) International Patent Classification:

A61L 17/00 (2006.01) C08J 7/12 (2006.01)  
D01F 11/14 (2006.01)

## (21) International Application Number:

PCT/IB2011/002429

## (22) International Filing Date:

25 July 2011 (25.07.2011)

## (25) Filing Language:

English

## (26) Publication Language:

English

## (30) Priority Data:

61/367,964 27 July 2010 (27.07.2010) US

(71) Applicant (for all designated States except US): **SO-FRADIM PRODUCTION** [FR/FR]; 116 avenue du Formans, F-01600 Trevoux (FR).

## (72) Inventor; and

(75) Inventor/Applicant (for US only): **LADET, Sebastien** [FR/FR]; 129 avenue Thiers, F-69006 Lyon (FR).(74) Agent: **CABINET GERMAIN & MAUREAU**; BP 6153, F-69466 Lyon Cedex 06 (FR).

(81) Designated States (unless otherwise indicated, for every kind of national protection available): AE, AG, AL, AM,

AO, AT, AU, AZ, BA, BB, BG, BH, BR, BW, BY, BZ, CA, CH, CL, CN, CO, CR, CU, CZ, DE, DK, DM, DO, DZ, EC, EE, EG, ES, FI, GB, GD, GE, GH, GM, GT, HN, HR, HU, ID, IL, IN, IS, JP, KE, KG, KM, KN, KP, KR, KZ, LA, LC, LK, LR, LS, LT, LU, LY, MA, MD, ME, MG, MK, MN, MW, MX, MY, MZ, NA, NG, NI, NO, NZ, OM, PE, PG, PH, PL, PT, RO, RS, RU, SC, SD, SE, SG, SK, SL, SM, ST, SV, SY, TH, TJ, TM, TN, TR, TT, TZ, UA, UG, US, UZ, VC, VN, ZA, ZM, ZW.

(84) Designated States (unless otherwise indicated, for every kind of regional protection available): ARIPO (BW, GH, GM, KE, LR, LS, MW, MZ, NA, SD, SL, SZ, TZ, UG, ZM, ZW), Eurasian (AM, AZ, BY, KG, KZ, MD, RU, TJ, TM), European (AL, AT, BE, BG, CH, CY, CZ, DE, DK, EE, ES, FI, FR, GB, GR, HR, HU, IE, IS, IT, LT, LU, LV, MC, MK, MT, NL, NO, PL, PT, RO, RS, SE, SI, SK, SM, TR), OAPI (BF, BJ, CF, CG, CI, CM, GA, GN, GQ, GW, ML, MR, NE, SN, TD, TG).

## Published:

— with international search report (Art. 21(3))

## (88) Date of publication of the international search report:

26 October 2012

(54) Title: POLYMERIC FIBERS HAVING TISSUE REACTIVE MEMBERS

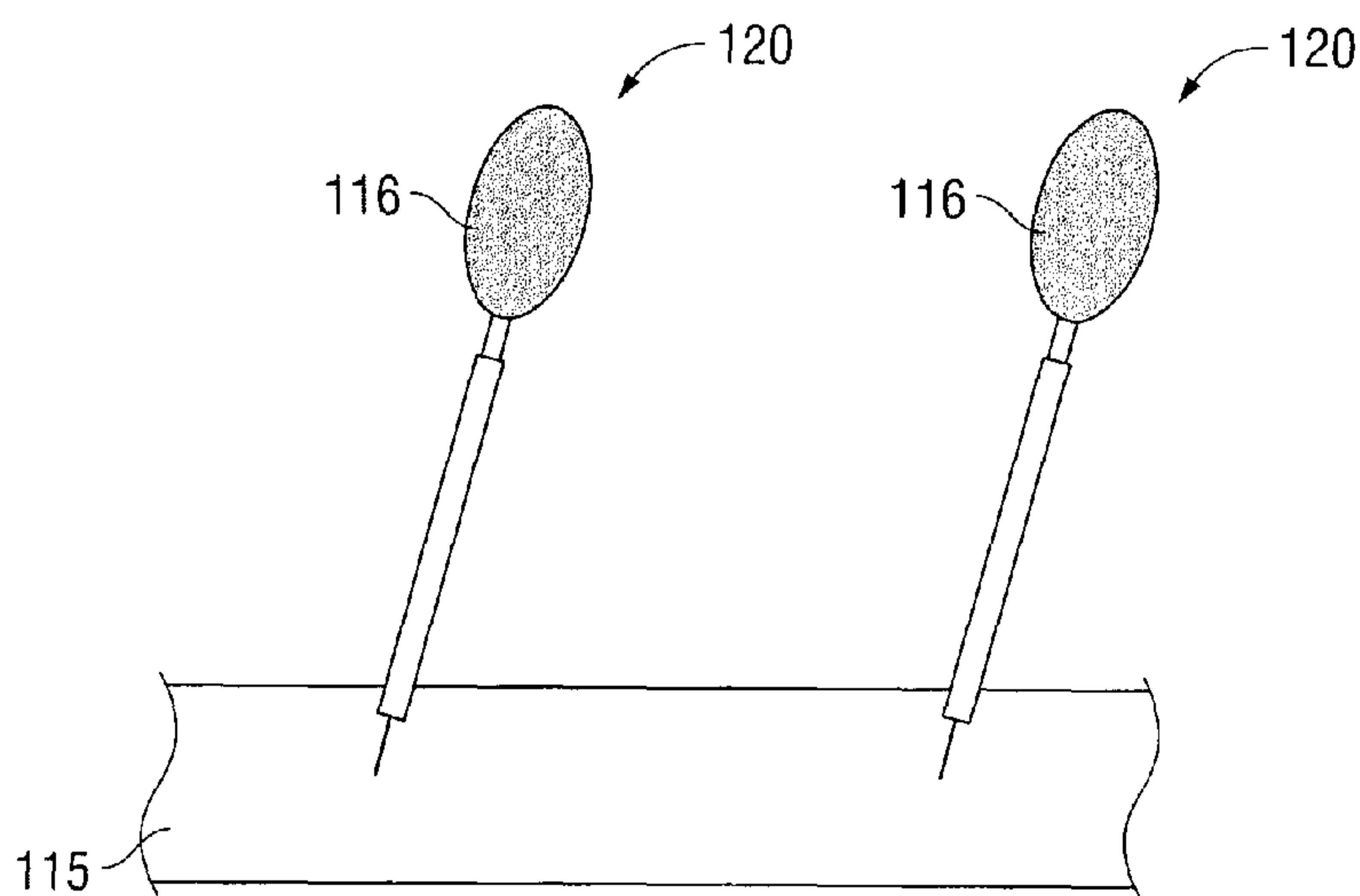

FIG. 2

(57) Abstract: A method for bonding a polymeric fiber to tissue is provided which includes providing a polymeric fiber having a plurality of tissue reactive members linked to a surface of the fiber via a specific binding pair, and contacting the polymeric fiber to biological tissue, to covalently bond the fiber to the tissue.

## POLYMERIC FIBERS HAVING TISSUE REACTIVE MEMBERS

### BACKGROUND

#### 5 1. Technical Field

The present disclosure relates to polymeric fibers having tissue reactive members and methods of bonding such polymeric fibers to biological tissues.

#### 2. Related Art

Techniques for repairing damaged or diseased tissue are widespread in medicine. 10 Wound closure devices such as sutures, staples and other repair devices such as mesh or patch reinforcements are frequently used for repair. For example, in the case of hernias, techniques involving the use of a mesh or patch to reinforce the abdominal wall are being used. The mesh or patch can generally be held in place by suturing or stapling to the surrounding tissue. Unfortunately, the use of such sutures or staples may increase the 15 patient's discomfort and, in certain instances, there may be a risk of weakening thin or delicate tissue when the sutures or staples are knotted or deformed.

Click chemistry is a popular term for reliable reactions that make it possible for certain chemical building blocks to “click” together and form an irreversible linkage. See, e.g., US Pub. No. 2005/0222427. Since its recent introduction, click chemistry has been 20 used for ligation in biological and medical technology. In the case of azide-alkyne click chemistry, the reactions may be catalyzed or uncatalyzed. For example, copper-free click chemistry was recently developed by Bertozzi and colleagues using difluorinated cyclooctyne or DIFO, that reacts with azides rapidly at physiological temperatures without the need for a toxic catalyst. See, e.g., Baskin et al., Copper Free Click Chemistry

for Dynamic In Vivo Imaging, PNAS, vol. 104, no. 43, 16793-16797 (October 23, 2007).  
The critical reagent, a substituted cyclooctyne, possesses ring strain and electron-  
withdrawing fluorine substituents that together promote a [3+ 2] dipolar cycloaddition  
with azides. See also, US Pub. No. 2006/0110782 and Codelli et al., Second Generation  
5 Difluorinated Cyclooctynes for Copper-Free Click Chemistry, J.Am.Chem.Soc., vol. 130,  
no. 34, 11486-11493 (2008). Another suitable cyclooctyne is 6,7-dimethoxyazacyclooct-  
4-yne (DIMAC). See, Sletton and Bertozzi, A hydrophilic azacyclooctyne for Cu-free  
click chemistry, Org. Lett. (2008) 10 (14), 3097-3099. Other click chemistry reactions  
include Diels-Alder reactions, thiol-alkene reactions, and maleimide-thiol reactions.  
10 There is a continuing need to generate improvements in tissue repair technology and  
advance the state of the art.

#### **BRIEF DESCRIPTION OF THE DRAWINGS**

Figure 1 schematically illustrates a fiber prior to attachment of a linking member  
15 in accordance with an embodiment described herein.

Figure 2 schematically illustrates a fiber having a tissue reactive member  
covalently attached via a specific binding pair.

Figure 3 schematically illustrates a fiber closing wound tissue in accordance with  
an embodiment described herein.

20 Figure 4 schematically illustrates a fiber closing wound tissue in accordance with  
another embodiment described herein.



**SUMMARY**

The present disclosure describes a polymeric fiber including a surface having a plurality of surface reactive members of a specific binding pair, and a plurality of linking members, each linking member including at least one complimentary surface reactive member of the specific binding pair, and at least one tissue reactive member, wherein the surface reactive members and the complementary surface reactive members are covalently bonded, adhering the tissue reactive members to the surface of the fiber.

A method for bonding a polymeric fiber to biological tissue is also provided which includes: providing a polymeric fiber having a plurality of surface reactive members of a specific binding pair attached on a surface of the fiber; attaching a plurality of linking members to the surface of the polymeric fiber, each linking member having at least one complimentary surface reactive member of the specific binding pair to attach the linking member to the surface of the polymeric fiber and at least one tissue reactive member; and, contacting the polymeric fiber with the biological tissue, wherein upon contact of the tissue reactive members on the surface of the polymeric fiber with the biological tissue, covalent bonds are formed between the tissue reactive members and the biological tissue, thus adhering the polymeric fiber to the biological tissue.

In embodiments, the surface reactive members of the specific binding pair bind to one another via a reaction selected from the group consisting of Huisgen cycloaddition reaction, a Diels-Alder reaction and a thiol-ene reaction.

In embodiments, the members of the specific binding pair are alkynes and azides. For example, the surface reactive member is an alkyne and the complementary surface

reactive member is an azide. In embodiments, the surface reactive member is an azide and the complementary surface reactive member is an alkyne.

In embodiments, the reaction is catalyzed by copper to activate an alkyne and an azide for [3 + 2] cycloaddition.

5 In embodiments, the reaction involves a cyclooctyne reagent and an azide for [3 + 2] cycloaddition.

In other embodiments, the surface reactive member and the complimentary surface reactive member are thiols and alkenes.

In other embodiments, the surface reactive member and the complimentary  
10 surface reactive member are dienes and alkenes.

In embodiments, the polymeric fiber comprises a monofilament suture. In  
embodiments, the polymeric fiber comprises a multifilament suture. In embodiments, the  
polymeric fiber comprises a surgical staple.

In embodiments, the polymeric fiber is used to form a surgical mesh.

15 In embodiments, the polymeric fiber is made of a polymer selected from the  
group consisting of polycarbonates, polyolefins, polymethacrylates, polystyrenes,  
polyamides, polyurethanes, polyethylene terephthalate, poly (lactic acid), poly (glycolic  
acid), poly (hydroxybutyrate), dioxanones (e.g., 1,4-dioxanone),  $\delta$ -valerolactone,  
1,dioxepanones (e.g., 1,4-dioxepan-2-one and 1,5-dioxepan-2-one), poly (phosphazine),  
20 polyesters, polyethylene glycol, polyethylene oxides, polyacrylamides, cellulose esters,  
fluoropolymers, vinyl polymers, silk, collagen, alginate, chitin, chitosan, hyaluronic acid,  
chondroitin sulfate, polyhydroxyethylmethacrylate, polyvinylpyrrolidone, polyvinyl  
alcohol, polyacrylic acid, polyacetate, polycaprolactone, polypropylene, glycerols,

poly(amino acids), copoly (ether-esters), polyalkylene oxalates, polyamides, poly (iminocarbonates), polyalkylene oxalates, polyoxaesters, polyorthoesters, polyphosphazenes, polypeptides and copolymers, block copolymers, homopolymers, blends and combinations thereof.

5           In embodiments, the tissue reactive member is an electrophile. In embodiments, the tissue reactive member is a nucleophile.

          In embodiments, the polymeric fiber comprises at least one barb.

### **DETAILED DESCRIPTION**

10           A surgical bonding system is provided in which fibers or filaments having pendant tissue reactive members covalently bond to biological tissue to close or seal a wound. The tissue reactive members may be attached to any portion of the fiber surface via a plurality of linking members. Each linking member includes at least one tissue reactive member and at least one complimentary surface reactive member of a specific binding pair. Prior to attachment of the linking member to the fiber, the fiber surface includes at least one surface reactive member of a specific binding pair, to which the complimentary surface reactive member of the linking member may covalently attach to the fiber. Once the linking member is attached to the fiber, a pendant tissue reactive member is positioned on the fiber for interaction with the biological tissue upon  
15  
20   implantation.

          In embodiments, the surface reactive members and the complimentary surface active members of a specific binding pair bind to one another via click chemistry. Click chemistry refers to a collection of surface reactive members having a high chemical

potential energy capable of producing highly selective, high yield reactions. The surface reactive members react to form extremely reliable molecular connections in most solvents, including physiologic fluids, and often do not interfere with other reagents and reactions. Examples of click chemistry reactions include Huisgen cycloaddition, Diels-  
5 Alder reactions, thiol-alkene reactions, and maleimide-thiol reactions.

Huisgen cycloaddition is the reaction of a dipolarophile with a 1,3-dipolar compound that leads to 5-membered (hetero)cycles. Examples of dipolarophiles are alkenes and alkynes and molecules that possess related heteroatom functional groups (such as carbonyls and nitriles). 1,3-Dipolar compounds contain one or more heteroatoms  
10 and can be described as having at least one mesomeric structure that represents a charged dipole. They include nitril oxides, azides, and diazoalkanes. Metal catalyzed click chemistry is an extremely efficient variant of the Huisgen 1,3-dipolar cycloaddition reaction between alkyl-aryl-sulfonyl azides, C-N triple bonds and C-C triple bonds which is well-suited herein. The results of these reactions are 1,2 oxazoles, 1,2,3 triazoles  
15 or tetrazoles. For example, 1,2,3 triazoles are formed by a copper catalyzed Huisgen reaction between alkynes and alkyl/aryl azides. Metal catalyzed Huisgen reactions proceed at ambient temperature, are not sensitive to solvents, i.e., nonpolar, polar, semipolar, and are highly tolerant of functional groups. Non-metal Huisgen reactions (also referred to as strain promoted cycloaddition) involving use of a substituted  
20 cyclooctyne, which possesses ring strain and electron-withdrawing substituents such as fluorine, that together promote a [3+ 2] dipolar cycloaddition with azides are especially well-suited for use herein due to low toxicity as compared to the metal catalyzed reactions. Examples include DIFO and DIMAC. Reaction of the alkynes and azides is



very specific and essentially inert against the chemical environment of biological tissues.

One reaction scheme may be represented as:

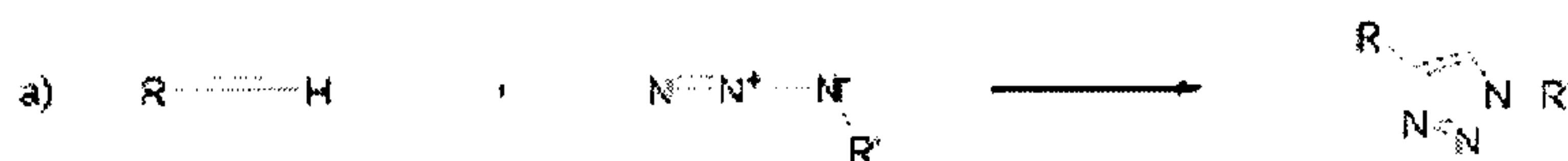

where R and R' are a polymeric material or a component of a biologic tissue.

5

The Diels-Alder reaction combines a diene (a molecule with two alternating double bonds) and a dienophile (an alkene) to make rings and bicyclic compounds.

Examples include:

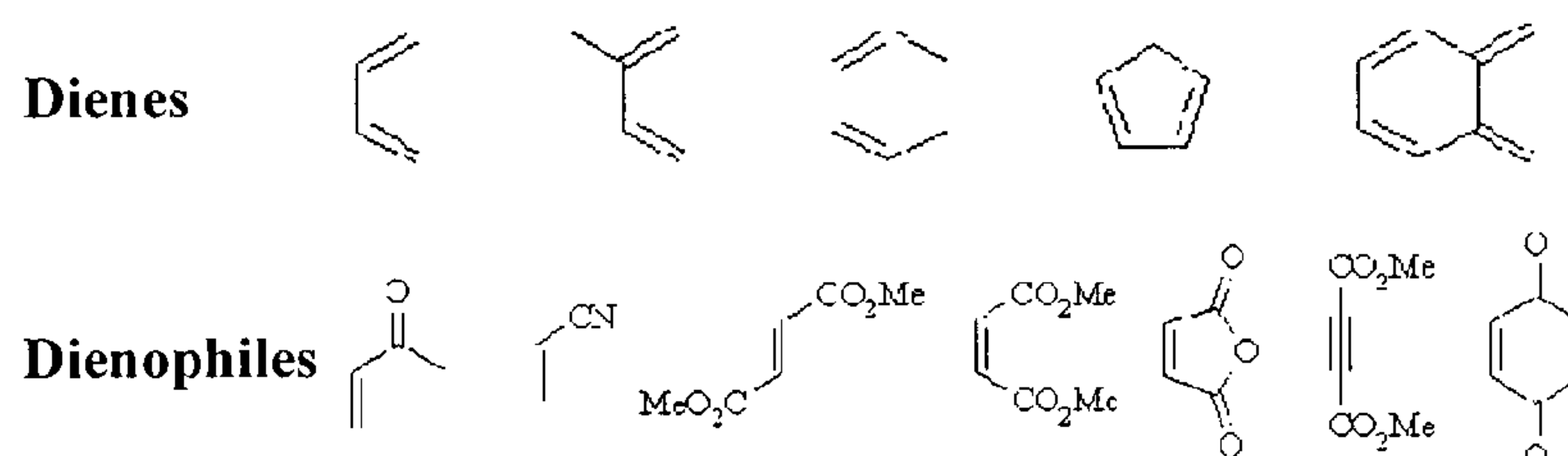

10

The thiol-alkene (thiol-ene) reaction is a hydrothiolation, i.e., addition of RS-H across a C=C bond. The thiol-ene reaction proceeds via a free-radical chain mechanism. Initiation occurs by radical formation upon UV excitation of a photoinitiator or the thiol itself. Thiol-ene systems form ground state charge transfer complexes and therefore photopolymerize even in the absence of initiators in reasonable polymerization times. However, the addition of UV light increases the speed at which the reaction proceeds. The wavelength of the light can be modulated as needed, depending upon the size and nature of the constituents attached to the thiol or alkene. A general thiol-ene coupling reaction mechanism is represented below:

15

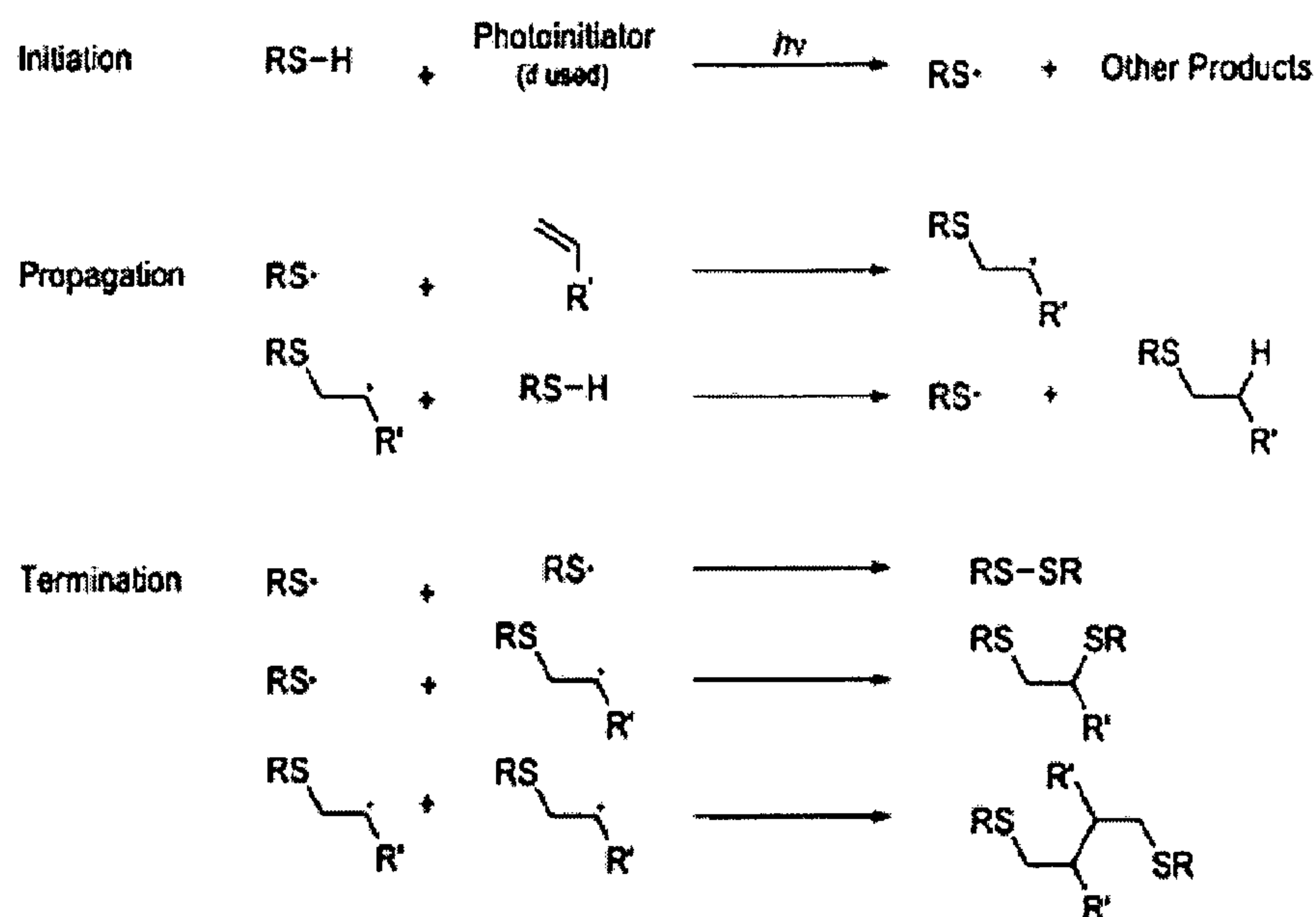

In accordance with the disclosure herein, a polymeric fiber, such as a surgical suture, is provided with a plurality of surface reactive members of a specific binding pair attached on the surface of the fiber. When the surface reactive members of the fiber are contacted with a linking member containing complementary surface reactive members of the specific binding pair, covalent attachment occurs, thus adhering the linking member to the fiber. In embodiments, the surface reactive members may be either a dipolarophile or a 1,3 dipolar compound depending on which complement is applied to the linking member or the fiber. For example, if a dipolarophile is located on the fiber, the 1,3 dipolar compound will be located on the linking member. If a dipolarophile is located on the linking member, the 1,3 dipolar compound will be located on the fiber. In embodiments, the Diels-Alder members of a specific binding pair may be either a diene and a dienophile depending on which complement is applied to the linking member or the fiber. For example, if a diene is located on the fiber, the dienophile can be located on the linking member. If a diene is located on the linking member, the dienophile can be

located on the fiber. In embodiments, the thiol-ene members of a specific binding pair may be either a thiol and an alkene depending on which complement is applied to the linking member or the fiber. For example, if a thiol is located on the fiber, the alkene can be located on linking member. If a thiol is located on the linking member, the alkene can be located on the fiber.

The polymeric fiber and the linking member may be constructed from any biocompatible absorbable polymer or biocompatible non-absorbable polymer. Examples of suitable polymers include polycarbonates, polyolefins, polymethacrylates, polystyrenes, polyamides, polyurethanes, polyethylene terephthalate, poly (lactic acid), poly (glycolic acid), poly (hydroxybutyrate), dioxanones (e.g., 1,4-dioxanone),  $\delta$ -valerolactone, 1,dioxepanones (e.g., 1,4-dioxepan-2-one and 1,5-dioxepan-2-one), poly (phosphazine), polyesters, polyethylene glycol, polyethylene oxides, polyacrylamides, cellulose esters, fluoropolymers, vinyl polymers, silk, collagen, alginate, chitin, chitosan, hyaluronic acid, chondroitin sulfate, glycosaminoglycans, polyhydroxyethylmethacrylate, polyvinylpyrrolidone, polyvinyl alcohol, polyacrylic acid, polyacetate, polycaprolactone, polypropylene, glycerols, poly(amino acids), copoly (ether-esters), polyalkylene oxalates, polyamides, poly (iminocarbonates), polyalkylene oxalates, polyoxaesters, polyorthoesters, polyphosphazenes, polypeptides and copolymers, block copolymers, homopolymers, blends and combinations thereof.

In the present application, the term "bioresorbable" and "bioabsorbable" are used interchangeably and are intended to mean the characteristic according to which an implant and/or a material is resorbed by the biological tissues and the surrounding fluids and disappears in vivo after a given period of time, that may vary, for example, from one

day to several months, depending on the chemical nature of the implant and/or of the material. Non bioresorbable material - also called permanent material - is not substantially resorbed by tissues and surrounding fluids, after 2 years and more, keeping in particular most (e.g., > 80 %) of their mechanical properties after such a time. The  
5 term "biocompatible" is intended to mean the characteristic according to which an implant and/or a material is well integrated by the biological tissues and the surrounding fluids without inducing excessive inflammation reaction around the bulk of the material or due to its degradation. The material should avoid also the formation of a fibrous capsule which usually results in the delay of the cellular integration of a porous implant.

10 Many of the above described examples of polymers do not contain functional groups in their molecules. In embodiments, the surface reactive members and complimentary surface reactive members are attached to the polymeric fiber or linking member by surface modification techniques such as plasma treatment, silane coupling treatment and acid sensitization. Surface activation of the fiber or linking member can be  
15 achieved by acid or base hydrolysis, treatment by means of cold plasma, by chemical reactions or electromagnetic radiations.

Hydrolysis can be conducted in the presence of an aqueous solution of a base or an acid to accelerate surface reaction, inasmuch as excessively long processes of activation can induce a reduction in molecular weight and thus in the mechanical  
20 properties of the material. Suitable bases for obtaining watery solutions suited to the aim are, for example, strong alkalis, such as LiOH, Ba(OH)<sub>2</sub>, Mg(OH)<sub>2</sub>, NaOH, KOH, Na<sub>2</sub>CO<sub>3</sub>, Ca(OH)<sub>2</sub> and the weak bases, such as for example NH<sub>4</sub> OH and the amines such as methylamine, ethylamine, diethylamine and dimethylamine. Acids suitable for surface



hydrolysis treatments can be chosen, for example, from among HCl, HClO<sub>3</sub>, HClO<sub>4</sub>, H<sub>2</sub>SO<sub>3</sub>, H<sub>2</sub>SO<sub>4</sub>, H<sub>3</sub>PO<sub>3</sub>, H<sub>3</sub>PO<sub>4</sub>, HI, HIO<sub>3</sub>, HBr, lactic acid, glycolic acid. Surface activation by means of hydrolysis can be conducted at temperatures preferably comprised between 0 degrees Celsius and the material softening temperature.

5 Plasma treatment can be carried out both in the presence of a reactive gas, for example air, Ar, O<sub>2</sub> with the formation of surface activation of oxygenate type, such as -OH, -CHO, -COOH.

Surface treatment, whether hydrolytic or with plasma, can remain unaltered or can be followed by further chemical modifications to provide the first reactive groups on the  
10 bioabsorbable polymeric surface. Thus, for example, the COONa groups generated by a base hydrolysis can be subsequently converted into COOH groups by treatment with strong mineral acids. Further, the surface freeing of alcoholic groups by means of a hydrolysis process can be followed by reaction by means of the addition of a compound provided with functional group or groups able to react with surface alcoholic groups,  
15 such as for example by means of the addition of an anhydride such as succinic anhydride, with the conversion of -OH groups into -O-CO-CH<sub>2</sub>-CH<sub>2</sub>-COOH groups. Suitable surface activation techniques are disclosed in U.S. Patent No. 6,107,453.

During manufacture of the polymeric fiber or linking member, pendant functional groups can be incorporated into the polymer backbone by, e.g., copolymerization with  
20 functionalized monomer such as lactones, cyclic carbonates and morpholine-2, 5-diones. The azido group, N<sub>3</sub> is a nucleophilic group that will exchange with other nucleophilic groups, e.g., -OH, -NH<sub>2</sub> and halogens (Br, Cl, or I). For example, 1,3-dipolar compounds

may be conjugated to aliphatic polyesters, by copolymerizing  $\epsilon$ -caprolactone and  $\alpha$ -chloro- $\epsilon$ -caprolactone and then substituting an azide group for the Cl atom. Polyesters can incorporate pendant dipolarophiles, e.g., propargyl groups, by copolymerization of  $\epsilon$ -caprolactone and  $\alpha$ -propargyl- $\delta$ -valerolactone. Copolymers of L-lactide containing  
5 propargyl groups may, e.g., be prepared by ring opening copolymerization of 5-methyl-5-propargyloxycarbonyl-1,3-dioxanone with L-lactide at a molar ratio of about 90:10 with  $\text{ZnEt}_2$  as a catalyst. See, Shi et al., *Biomaterials*, 29 (2008)1118-1126. Azide functionalized polystyrene is synthesized using atom transfer radical polymerization and subsequent modification with azidotrimethylsilane and tetrabutylammonium fluoride.  
10 See, Dirks, et al., *Chem. Comm.*, (2005) 4172-4174. Azides may be incorporated onto methacrylates, e.g., 3 azidopropyl methacrylate which is copolymerized to a block copolymer. Diels-Alder functionalities and thiol-ene functionalities are likewise incorporated into polymers herein.

In embodiments, the polymeric fiber may be a surgical suture. In some  
15 embodiments, the fiber may be a monofilament or a multifilament. In embodiments, the polymeric fiber may include at least one barb. In still other embodiments, the polymeric fiber may be used to form fibrous medical devices. Some non-limiting examples of such fibrous medical devices include sutures, staples, clips, patches and meshes.

The medical device may be selected from any conventional implantable fibrous  
20 device suitable for use in tissue reinforcement, e.g., hernia repair, or as an anti-adhesion barrier, hemostatic patch, bandages, pledgets, buttresses and the like. Any of the biocompatible polymers listed above may be utilized.

Indeed, the polymeric fibers described herein, as well as any fibrous medical device, may be formed using any techniques known to those skilled in the art, such as knitting, weaving, braiding, tatting, nonwoven techniques, freeze drying, solvent casting, extruding, molding, spinning, and the like. It is envisioned that the fibers may be formed  
5 from any permanent biocompatible materials (e.g. polyesters, polypropylene), biodegradable biocompatible materials (e.g. polylactic acid, polyglycolic acid, oxidized cellulose, and chitosan) or with a combination at any proportion of both permanent and biodegradable materials.

The surface of the polymeric fiber or device includes at least one surface reactive  
10 member before the linking member is attached to the fiber. The linking member is provided with at least one complimentary surface reactive member to interact with the surface reactive member of the fiber to form a covalent bond between the fiber and the linking member. The linking member also includes a tissue reactive member which remains capable of interacting with the biological tissue when implanted.

15 In embodiments, a linking member may be a polymeric material made from any of the suitable polymeric materials described herein. Like some polymeric fibers, the linking member may naturally include the complimentary surface reactive members, however in some embodiments, the linking members may require the addition or attachment of the complimentary surface reactive member. Similarly, the linking  
20 member may naturally include the tissue reactive members or the linking members may require the addition or attachment of the tissue reactive members.

The tissue reactive members are functional groups or other molecular segments that react with electrophilic or nucleophilic moieties present at the tissue site, e.g., amino

and sulfhydryl groups on peptides, proteins, cell surfaces, and extracellular matrix components, to form covalent bonds. Generally, and as will be appreciated by those skilled in the art, the moieties at the tissue site are nucleophilic. Thus, in certain embodiments, the tissue reactive members may be electrophilic.

5           The term “nucleophilic” refers to a functional member that is electron rich, has an unshared pair of electrons acting as a reactive site, and reacts with a positively charged or electron-deficient site, generally present on another molecule. The term “nucleophile” refers to a compound having a nucleophilic site.

          The term “electrophilic” refers to a functional member that is susceptible to  
10 nucleophilic attack, i.e., susceptible to reaction with an incoming nucleophilic member. Electrophilic members herein are typically electron-deficient. The term “electrophile” refers to a compound having an electrophilic site. General examples of electrophilic reactive members include (1) alkenyloxycarbonyl groups, i.e., carboxylic acid esters, and “activated” esters; (2) halocarbonyl groups such as acid chloride groups ( $\text{—CO—Cl}$ ); (3)  
15 anhydrides ( $\text{—(CO)—O—(CO)—R}$ , where R is substituted or unsubstituted alkyl, aryl, alkaryl, etc.); (4) acyl groups (ketones) and formyl groups (aldehydes), including  $\alpha,\beta$ -unsaturated ketones and aldehydes (e.g.,  $\text{—CH=CH—CH=O}$  and  $\text{—CH=CH—C(CH}_3\text{)=O}$ ); (5) halides, particularly chloro substituents; (6) isocyano groups ( $\text{—N=C=O}$ ); (7) isothiocyano groups ( $\text{—N=C=S}$ ); (8) epoxides; (9) activated hydroxyl  
20 groups (e.g., activated with conventional activating agents such as carbonyldiimidazole or sulfonyl chloride); and (10) alkenyl groups, including conjugated olefins, such as ethenesulfonyl ( $\text{—SO}_2\text{CH=CH}_2$ ) and analogous functional groups, including acrylate ( $\text{—CO}_2\text{—C=CH}_2$ ), methacrylate ( $\text{—CO}_2\text{—C(CH}_3\text{)=CH}_2$ ), ethyl acrylate ( $\text{—CO}_2\text{—$



$C(CH_2CH_3)=CH_2$ ), and ethyleneimino ( $—CH=CH—C=NH$ ).

Further examples of electrophilic tissue reactive members include, without limitation: mixed anhydrides such as PEG-glutaryl-acetyl-anhydride; PEG-glutaryl-isovaleryl-anhydride; PEG-glutaryl-pivalyl-anhydride; ester derivatives of p-nitrophenol, p-nitrothiophenol, and pentafluorophenol; esters of substituted hydroxylamines such as those of N-hydroxy-phthalimide, N-hydroxy-succinimide, and N-hydroxy-glutarimide; esters of 1-hydroxybenzotriazole, 3-hydroxy-3,4-dihydrobenzotriazine-4-one and 3-hydroxy-3,4-dihydro-quinazoline-4-one; derivatives of carbonylimidazole; and isocyanates. With these compounds auxiliary reagents can also be used to facilitate bond formation. For example 1-ethyl-3-(3-dimethylaminopropyl)]carbodiimide can be used to facilitate coupling of carboxyl groups (i.e., glutarate and succinate) with sulfhydryl groups.

It is envisioned that certain tissue reactive members may be more selective to different layers or types of biological tissue. For example, the FGF (fibroblast growth factor) is a ligand selective for the fibroblast cells which may be found in connective tissues and/or the dermal layer of a human's skin. In another example, the  $\beta 1$  integrin is a ligand selective for the keratinocytes which may be found in the epidermal layer of skin. In some embodiments, the polymeric fibers described herein may include pendant tissue reactive members specific to certain types of cells or tissue, i.e., FGF and  $\beta 1$  integrin.

In other embodiments, the linking member may be a ligand suitable for reacting with biological tissue and which bears a complimentary surface reactive member suitable for interacting with the surface reactive member on the fiber. The ligand may bind

naturally to a desired target on the tissue and thus provides a vehicle for transporting and directly binding the polymeric fiber to the tissue. The ligand herein is any molecule or combination of molecules which demonstrates an affinity for biological tissue or a target in the biological tissue. Examples of ligands include nucleic acid probes, antibodies, 5 hapten conjugates, and cell adhesion peptides such as RGD. The mechanisms involved in obtaining and using such ligands are well-known. In embodiments, complimentary surface reactive members or complementary reactive members are incorporated into saccharides or polysaccharides and attached to the fiber prior to contact with cellular tissue, wherein upon contact with the tissue the polysaccharides may be metabolically 10 incorporated into cells. See, e.g., Baskin et al., *supra*.

Antibodies that specifically recognize antigens are useful in accordance with one embodiment herein. Antibodies which are conjugated to a complimentary surface reactive member are utilized to bind to proteins located on tissue. Monoclonal or polyclonal antibodies are raised against an antigen which can be any component of biological tissue 15 and then purified using conventional techniques. The term "antibody" is intended to include whole antibodies, e.g., of any isotype (IgG, IgA, IgM, IgE, etc.), and to include fragments thereof which are also specifically reactive with a vertebrate, e.g., mammalian, protein. Antibodies may be fragmented using conventional techniques and the fragments screened for utility in the same manner as for whole antibodies. Thus, the term includes 20 segments of proteolytically-cleaved or recombinantly-prepared portions of an antibody molecule that are capable of selectively reacting with a certain protein. Non-limiting examples of such proteolytic and/or recombinant fragments include Fab, F(ab')<sub>2</sub>, Fab', Fv, and single chain antibodies (scFv) containing a V[L] and/or V[H] domain joined by a

peptide linker. The scFv's may be covalently or non-covalently linked to form antibodies having two or more binding sites. The present disclosure includes polyclonal, monoclonal or other purified preparations of antibodies and recombinant antibodies.

After purification, the ligands (e.g., antibodies, nucleic acid probes, hapten  
5 conjugates and cell adhesion peptides), are conjugated or linked to surface reactive members or complementary reactive members in the manners described above. In addition, surface reactive members or complementary reactive members can be linked to ligands by cross-linking procedures which, in accordance with the present invention, do not cause denaturing or misfolding of the ligands. The terms "linked", "attached", or  
10 "conjugated" as used herein are used interchangeably and are intended to include any or all of the mechanisms known in the art for coupling the surface reactive members, complementary surface reactive members, or tissue reactive members to the ligand and/or polymer materials. For example, any chemical or enzymatic linkage known to those with skill in the art is contemplated including those which result from photoactivation and the  
15 like. Homofunctional and heterobifunctional cross linkers are all suitable. Reactive groups (distinguishable from surface reactive members or complementary surface reactive members or tissue reactive members herein) which can be cross-linked with a cross-linker include primary amines, sulfhydryls, carbonyls, carbohydrates and carboxylic acids.

20 Cross-linkers are conventionally available with varying lengths of spacer arms or bridges. Cross-linkers suitable for reacting with primary amines include homobifunctional cross-linkers such as imidoesters and N-hydroxysuccinimidyl (NHS) esters. Examples of imidoester cross-linkers include dimethyladipimidate,

dimethylpimelimidate, and dimethylsuberimidate. Examples of NHS-ester cross-linkers include disuccinimidyl glutamate, disuccinimidyl suberate and bis (sulfosuccinimidyl) suberate. Accessible amine groups present on the N-termini of peptides react with NHS-esters to form amides. NHS-ester cross-linking reactions can be conducted in phosphate, bicarbonate/carbonate, HEPES and borate buffers. Other buffers can be used if they do not contain primary amines. The reaction of NHS-esters with primary amines should be conducted at a pH of between about 7 and about 9 and a temperature between about 4°C and 30°C for about 30 minutes to about 2 hours. The concentration of NHS-ester cross-linker can vary from about 0.1 to about 10 mM. NHS-esters are either hydrophilic or hydrophobic. Hydrophilic NHS-esters are reacted in aqueous solutions although DMSO may be included to achieve greater solubility. Hydrophobic NHS-esters are dissolved in a water miscible organic solvent and then added to the aqueous reaction mixture.

Sulfhydryl reactive cross-linkers include maleimides, alkyl halides, aryl halides and  $\alpha$ -haloacetyls which react with sulfhydryls to form thiol ether bonds and pyridyl disulfides which react with sulfhydryls to produce mixed disulfides. Sulfhydryl groups on peptides and proteins can be generated by techniques known to those with skill in the art, e.g., by reduction of disulfide bonds or addition by reaction with primary amines using 2-iminothiolane. Examples of maleimide cross-linkers include succinimidyl 4-(N-maleimido-methyl) cyclohexane-1-carboxylate and m-maleimidobenzoyl-N-hydroxysuccinimide ester. Examples of haloacetal cross-linkers include N-succinimidyl (4-iodoacetal) aminobenzoate and sulfosuccinimidyl (4-iodoacetal) aminobenzoate. Examples of pyridyl disulfide cross-linkers include 1,4-Di-[3'-2'-pyridyldithio(propionamido)butane] and N-succinimidyl-3-(2-pyridyldithio)-propionate.



Carboxyl groups are cross-linked to primary amines or hydrazides by using carbodimides which result in formation of amide or hydrazone bonds. In this manner, carboxy-termini of peptides or proteins can be linked. Examples of carbodiimide cross-linkers include 1-ethyl-3-(3-dimethylaminopropyl)-carbodiimide hydrochloride and N, 5 N<sup>1</sup>-dicyclohexylcarbodiimide. Arylazide cross-linkers become reactive when exposed to ultraviolet radiation and form aryl nitrene. Examples of arylazide cross-linkers include azidobenzoyl hydrazide and N-5-azido-2 nitrobenzoyloxysuccinimide. Glyoxal cross linkers target the guanidyl portion of arginine. An example of a glyoxal cross-linker is p-azidophenyl glyoxal monohydrate.

10 Heterobifunctional cross-linkers which possess two or more different reactive groups are suitable for use herein. Examples include cross-linkers which are amine-reactive at one end and sulfhydryl-reactive at the other end such as 4-succinimidyl-oxycarbonyl-a-(2-pyridyldithio)-toluene, N- succinimidyl-3-(2-pyridyldithio)-propionate and the maleimide cross-linkers discussed above.

15 Attachment of surface reactive members to the polymeric fiber provides the fiber with the ability to form a covalent bond with the linking member upon exposure to the complementary surface reactive members on the linking member.

Attachment of tissue reactive members to the polymeric fiber provides the fiber with the ability to form covalent bonds with the biological tissue upon implantation, thus 20 adhering the fiber to the tissue.

In one embodiment, a linking member is degradable by, e.g., hydrolysis or enzymatic action. In this manner, the fiber can be removable from the tissue and/or the linking member after a period of time. The degradable linkage may be, e.g., chelates or

chemically or enzymatically hydrolyzable or absorbable. Illustrative chemically hydrolyzable degradable linkages include polymers, copolymers and oligomers of glycolide, dl-lactide, l-lactide, caprolactone, dioxanone, and trimethylene carbonate. Illustrative enzymatically hydrolyzable biodegradable linkages include peptidic linkages cleavable by metalloproteinases and collagenases. Additional illustrative degradable linkages include polymers and copolymers of poly(hydroxy acid)s, poly(orthocarbonate)s, poly(anhydride)s, poly(lactone)s, poly(amino acid)s, poly(carbonate)s, poly(saccharide)s and poly(phosphonate)s. In certain embodiments, the degradable linkage may contain ester linkages. Some non-limiting examples include esters of succinic acid, glutaric acid, propionic acid, adipic acid, or amino acids, as well as carboxymethyl esters.

The polymeric fibers described herein may be cut to a desired length or shape, packaged in suture packaging or single or dual packages and sterilized by gamma or beta irradiation at 25-35 Kgy or by ethylene oxide.

Turning now to Figure 1, polymeric fiber 15 includes surface reactive members, in this case azide groups 12. Linking members 20 including complimentary surface reactive members, in this case alkyne groups 14, and tissue reactive members 16, may be attached to fiber 15 upon interaction or contact of surface reactive members 12 with complimentary surface reactive members 14. As those skilled in the art will recognize, reaction times between the azide and alkyne members can be reduced from about 24 hours at room temperature to mere seconds at room temperature by the presence of transition metal ions, such as copper ions or upon exposure to ultraviolet light.

As depicted in Figure 2, linking member 120 is attached to polymeric fiber 115. In addition, polymeric fiber 115 also includes pendant tissue reactive members 116 which are capable of interacting with biological tissue to covalently attach fiber 115 to the tissue following implantation. In embodiments wherein the surface reactive member is an  
5 alkyne and the complimentary surface reactive member is an azide, the linking member may be attached to the fiber via a triazole (not shown).

Unlike conventional wound closure devices, the polymeric fibers described herein may not need to form a knot or be crimped to maintain closure of the wound tissue. As shown in Figure 3, fiber 215, i.e., a surgical suture, may be passed through approximated  
10 wound tissue 240 to close or seal wound tissue 240. Because pendant tissue reactive members 216 of fiber 215 form covalent bonds with at least portions of tissue 240a, polymeric fiber 215 may be able to maintain closure of wound tissue 240 without the need of forming a knot in fiber 215.

Similarly, in Figure 4, fiber 315, i.e., a surgical staple, may be passed through  
15 approximated wound tissue 340 to close or seal wound tissue 340. Because pendant tissue reactive members 316 of fiber 315 form covalent bonds with at least portions of tissue 340a, polymeric fiber 315 may be able to maintain closure of wound tissue 340 without the need of crimping fiber 315.

It should be understood that variations can be made to the above embodiments  
20 that are within the purview of ordinary skill in the art. For example, other click chemistry reactions are suitable for use herein, e.g., Staudinger reaction of phosphines with alkyl azides. It is contemplated that the above-described cross-linkers may be applied to polymers which make up the fiber to bind reactive members or complementary reactive

members thereto. Accordingly, those skilled in the art can envision modifications which are included within the scope of the claimed invention that are not expressly set forth herein.



The embodiments of the present invention for which an exclusive property or privilege is claimed are defined as follows:

1. A surgical suture comprising a polymeric fiber comprising:  
  
a surface having a plurality of surface reactive members of a specific binding pair; and  
  
a plurality of linking members, each linking member including at least one complimentary surface reactive member of the specific binding pair, and at least one tissue reactive member, wherein the surface reactive members and the complimentary surface reactive members are covalently bonded, adhering the tissue reactive members to the surface of the fiber;  
  
wherein the at least one tissue reactive member is an electrophile, and  
  
wherein the at least one tissue reactive member forms covalent bonds with biological tissue.
2. The surgical suture according to claim 1 wherein the surface reactive members of the specific binding pair bind to one another via a reaction selected from the group consisting of Huisgen cycloaddition reaction, a Diels-Alder reaction and a thiolene reaction.
3. The surgical suture according to claim 1 or 2 wherein the members of the specific binding pair are alkynes and azides.
4. The surgical suture according to any one of claims 1 to 3 wherein the surface reactive member is an alkyne and the complimentary surface reactive member is an azide.

5. The surgical suture according to any one of claims 1 to 3 wherein the surface reactive member is an azide and the complimentary surface reactive member is an alkyne.
6. The surgical suture according to any one of claims 2 to 5 wherein the reaction is catalyzed by copper to activate an alkyne and an azide for [3 + 2] cycloaddition.
7. The surgical suture according to any one of claims 2 to 5 wherein the reaction involves a cyclooctyne reagent and an azide for [3 + 2] cycloaddition.
8. The surgical suture according to claim 1 or 2 wherein the surface reactive member and the complimentary surface reactive member are thiols and alkenes.
9. The surgical suture according to claim 1 or 2 wherein the surface reactive member and the complimentary surface reactive member are dienes and alkenes.
10. The surgical suture according to any one of claim 1 to 9 wherein the surgical suture is a monofilament suture.
11. The surgical suture according to any one of claims 1 to 9 wherein the surgical suture is a multifilament suture.
12. The surgical suture according to any one of claims 1 to 11 wherein the polymeric fiber is made of a polymer selected from the group consisting of polycarbonates, polyolefins, polymethacrylates, polystyrenes, polyamides, polyurethanes, polyethylene terephthalate, poly(lactic acid), poly(glycolic acid), poly(hydroxybutyrate), dioxanones,  $\delta$ -valerolactone, 1,dioxepanones, poly(phosphazine), polyesters, polyethylene glycol, polyethylene oxides,

polyacrylamides, cellulose esters, fluoropolymers, vinyl polymers, silk, collagen, alginate, chitin, chitosan, hyaluronic acid, chondroitin sulfate, polyhydroxyethylmethacrylate, polyvinylpyrrolidone, polyvinyl alcohol, polyacrylic acid, polyacetate, polycaprolactone, polypropylene, glycerols, poly(amino acids), copoly (ether-esters), polyalkylene oxalates, polyamides, poly (iminocarbonates), polyalkylene oxalates, polyoxaesters, polyorthoesters, polyphosphazenes, polypeptides and copolymers, block copolymers, homopolymers, blends and combinations thereof.

13. The surgical suture according to claim 12 wherein the dioxanones comprise 1,4-dioxanone.

14. The surgical suture according to claim 12 wherein the 1,dioxepanones comprise 1,4-dioxepan 2-one or 1,5-dioxepan-2-one.

15. The surgical suture according to any one of claims 1 to 14 wherein the polymeric fiber comprises at least one barb.

1/2

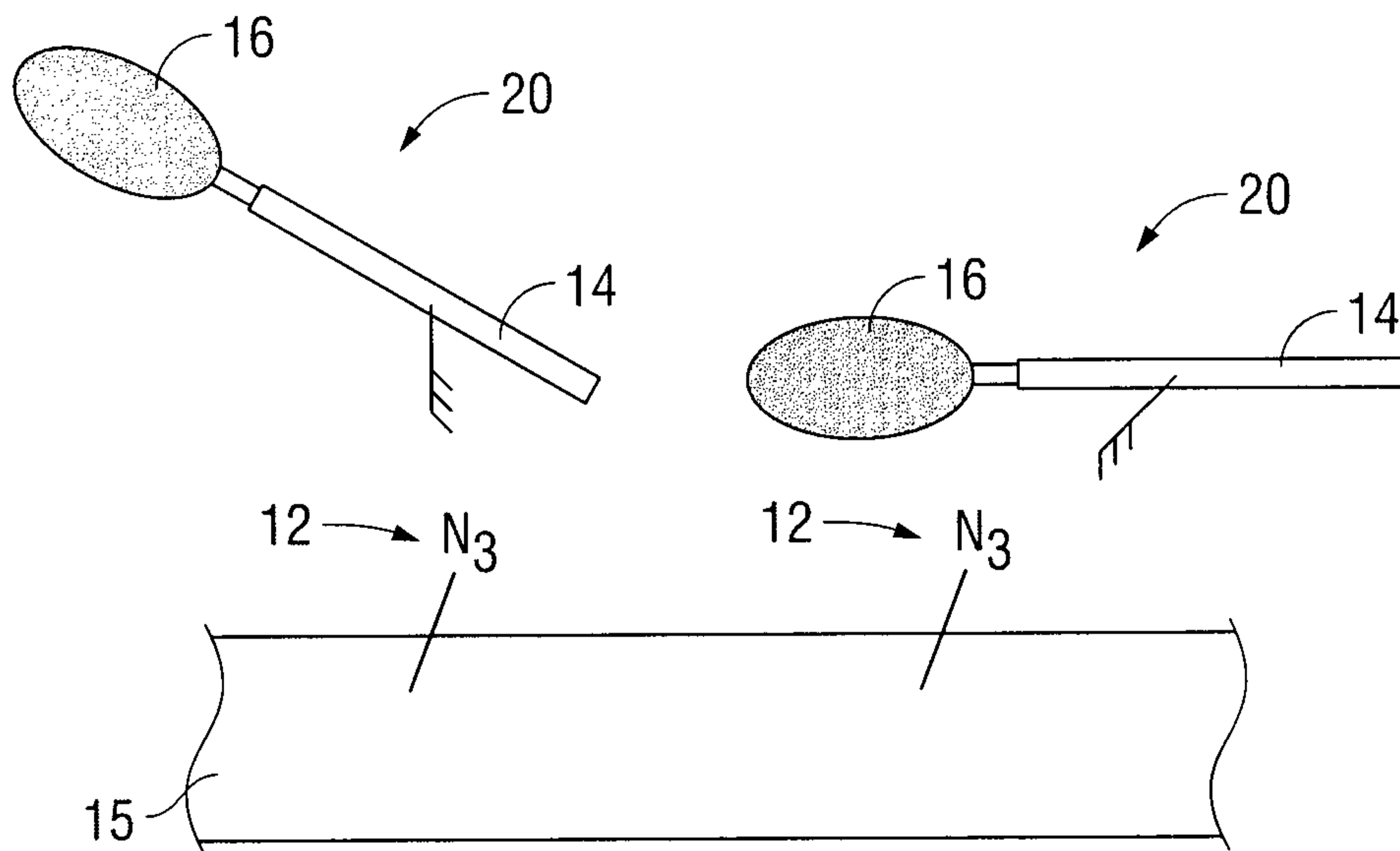

FIG. 1

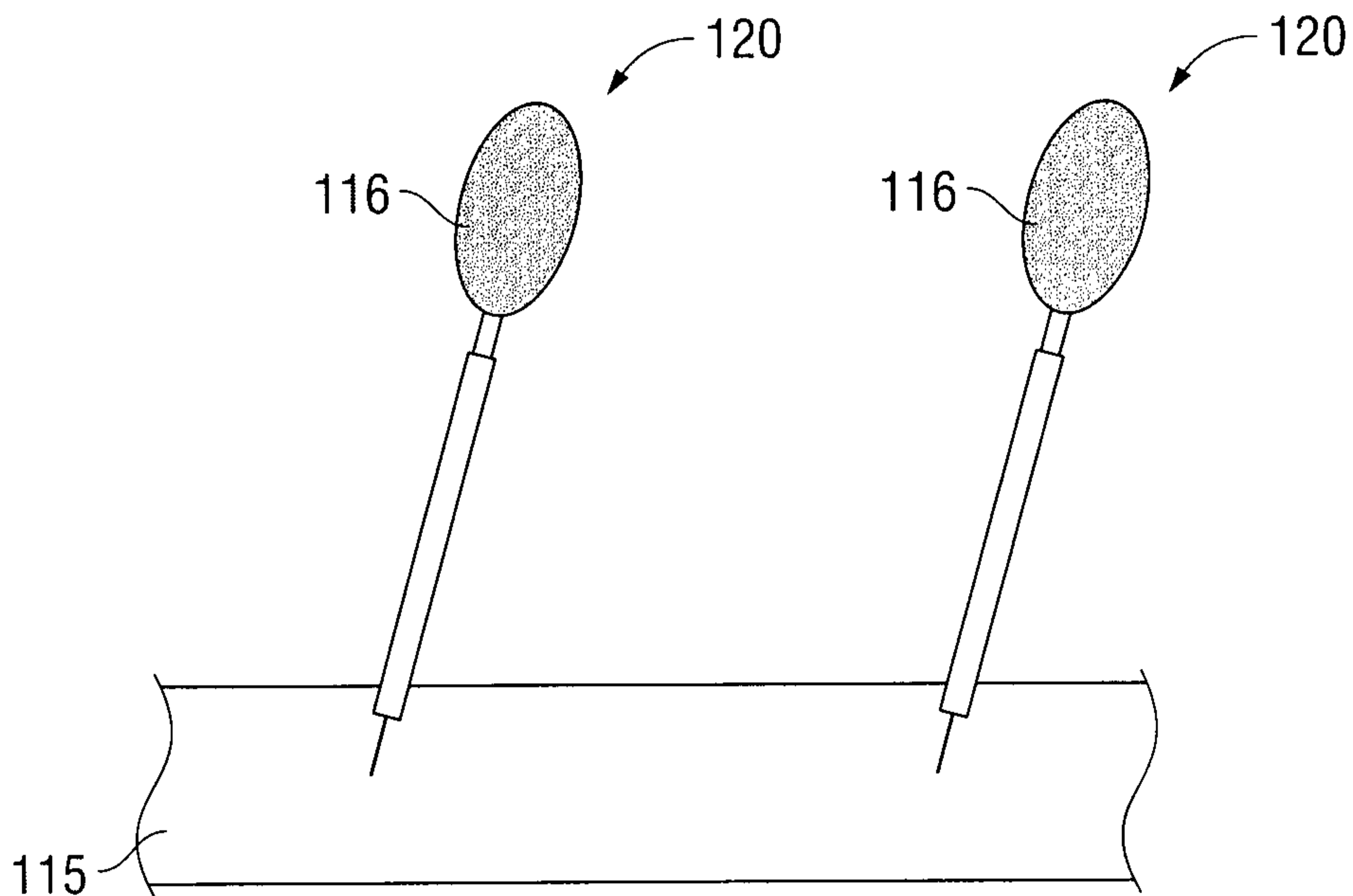

FIG. 2



2/2

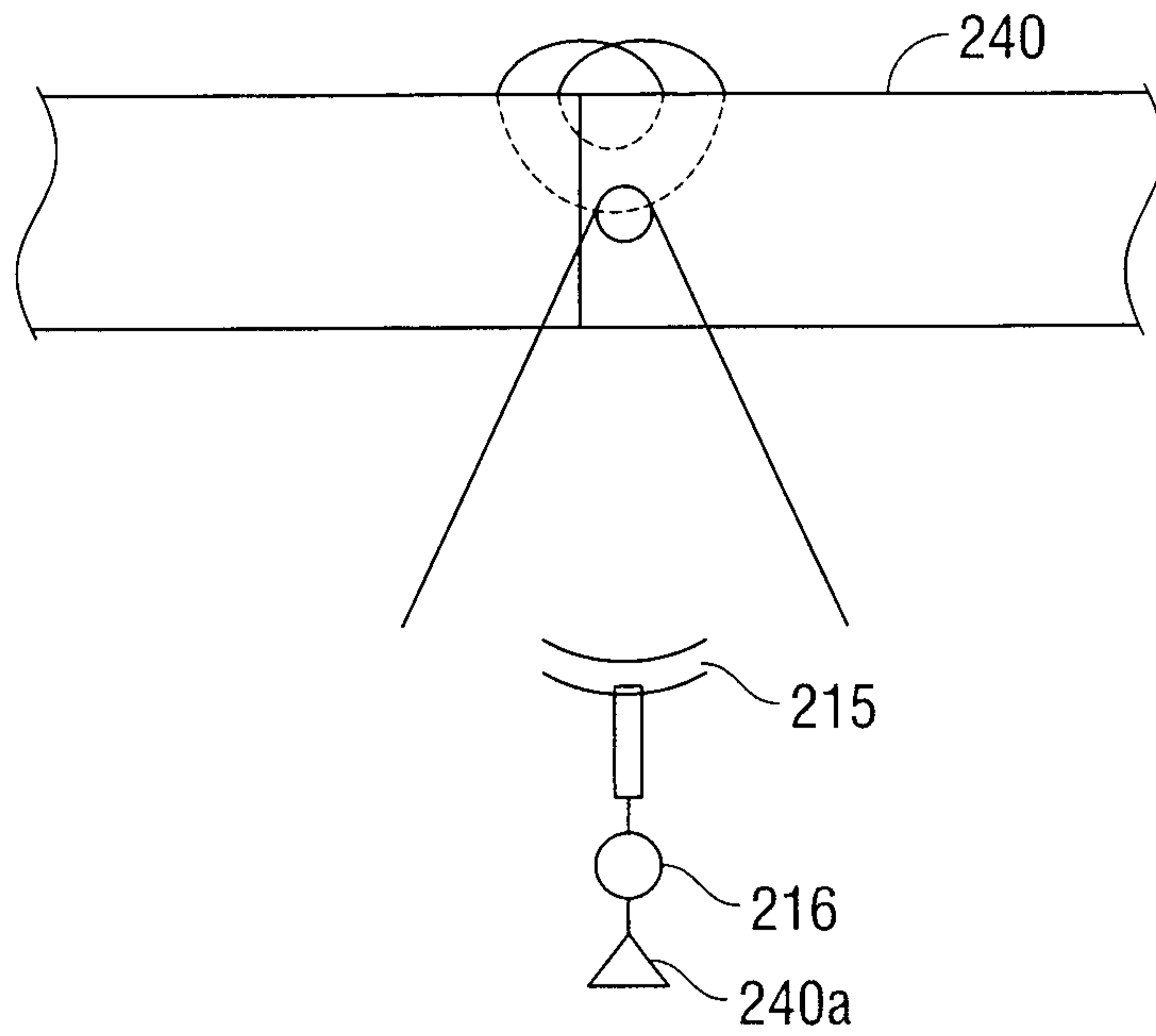

FIG. 3

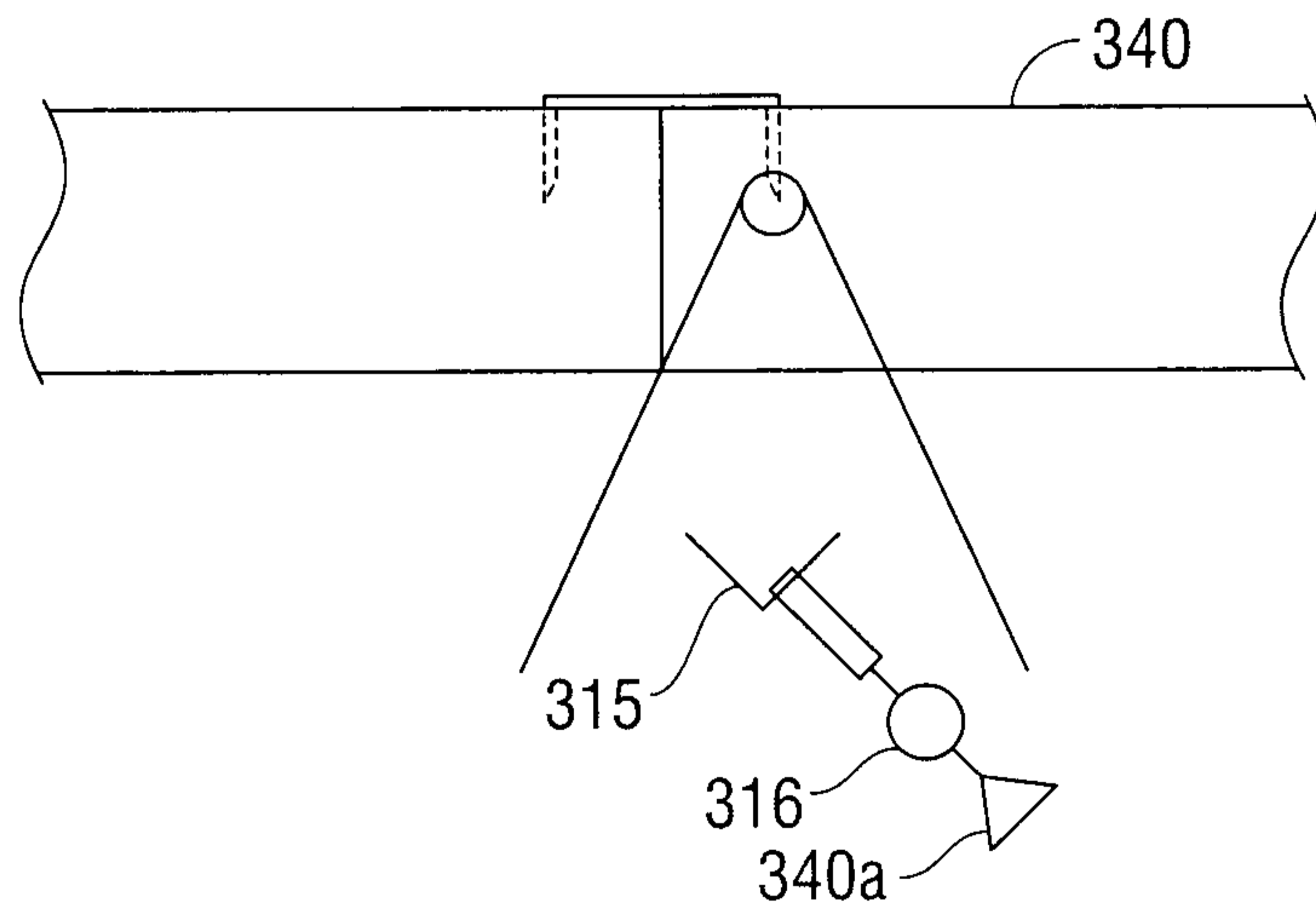

FIG. 4

