



US 20060179732A1

(19) **United States**

(12) **Patent Application Publication**

**Strasso**

(10) **Pub. No.: US 2006/0179732 A1**

(43) **Pub. Date: Aug. 17, 2006**

(54) **APPARATUS AND METHOD FOR  
INSTALLING FUNCTIONAL  
NON-ARCHITECTURAL ELEMENTS**

**Publication Classification**

(51) **Int. Cl.**  
*E04D 13/18* (2006.01)

(52) **U.S. Cl.** ..... 52/173.3

(76) **Inventor: Pasquale Strasso, Terni (IT)**

(57) **ABSTRACT**

Correspondence Address:  
**NIXON & VANDERHYE, PC**  
**901 NORTH GLEBE ROAD, 11TH FLOOR**  
**ARLINGTON, VA 22203 (US)**

An apparatus comprises a covering arrangement suitable for covering a water tank which can be mounted onto an external portion of a building, said covering arrangement being made in the shape of an architectural component, and further comprises an angular positioning device such as to keep said tank in a substantially vertical position; an apparatus comprises a covering arrangement suitable for covering a component of an air-conditioning system which can be mounted onto an external portion of a building, said covering arrangement being made in the shape of an architectural component; a method comprises: reproducing a selected part of a building to get an image therefrom on a layer element; applying said layer element onto a supporting surface surrounding a functional non-architectural element.

(21) **Appl. No.: 10/562,199**

(22) **PCT Filed: Mar. 2, 2004**

(86) **PCT No.: PCT/EP04/02080**

(30) **Foreign Application Priority Data**

Jun. 26, 2003 (IT) ..... MO2003 A 000191

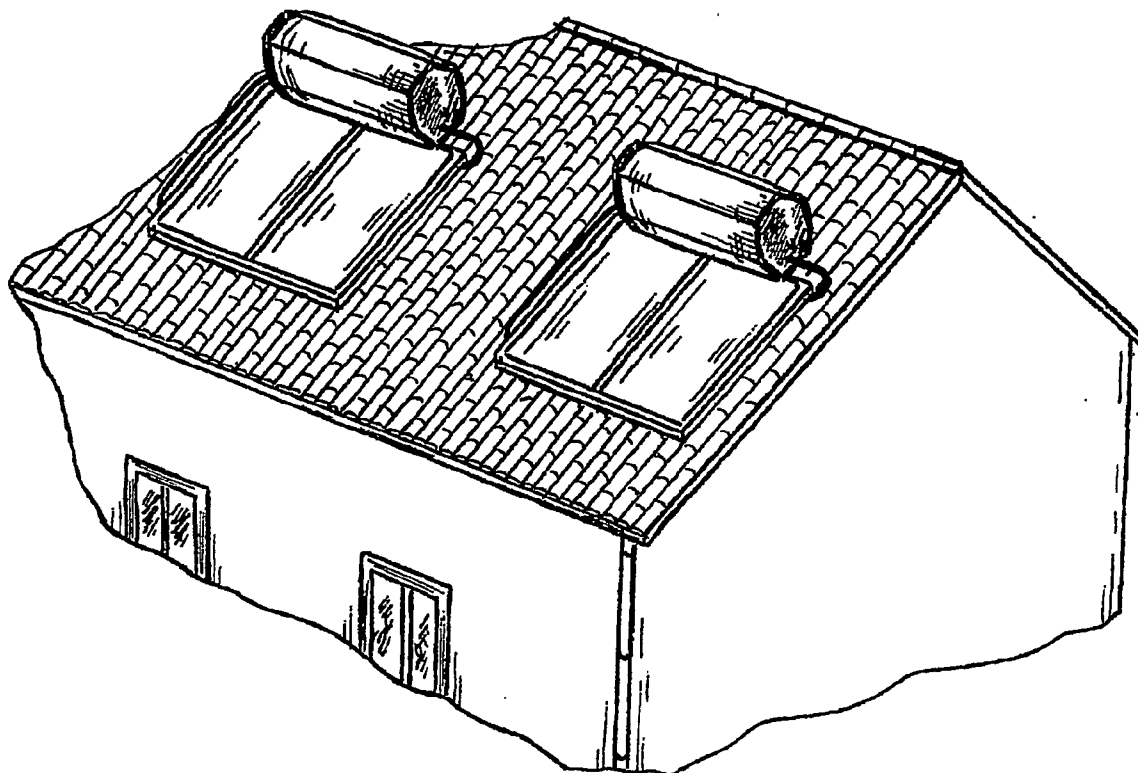

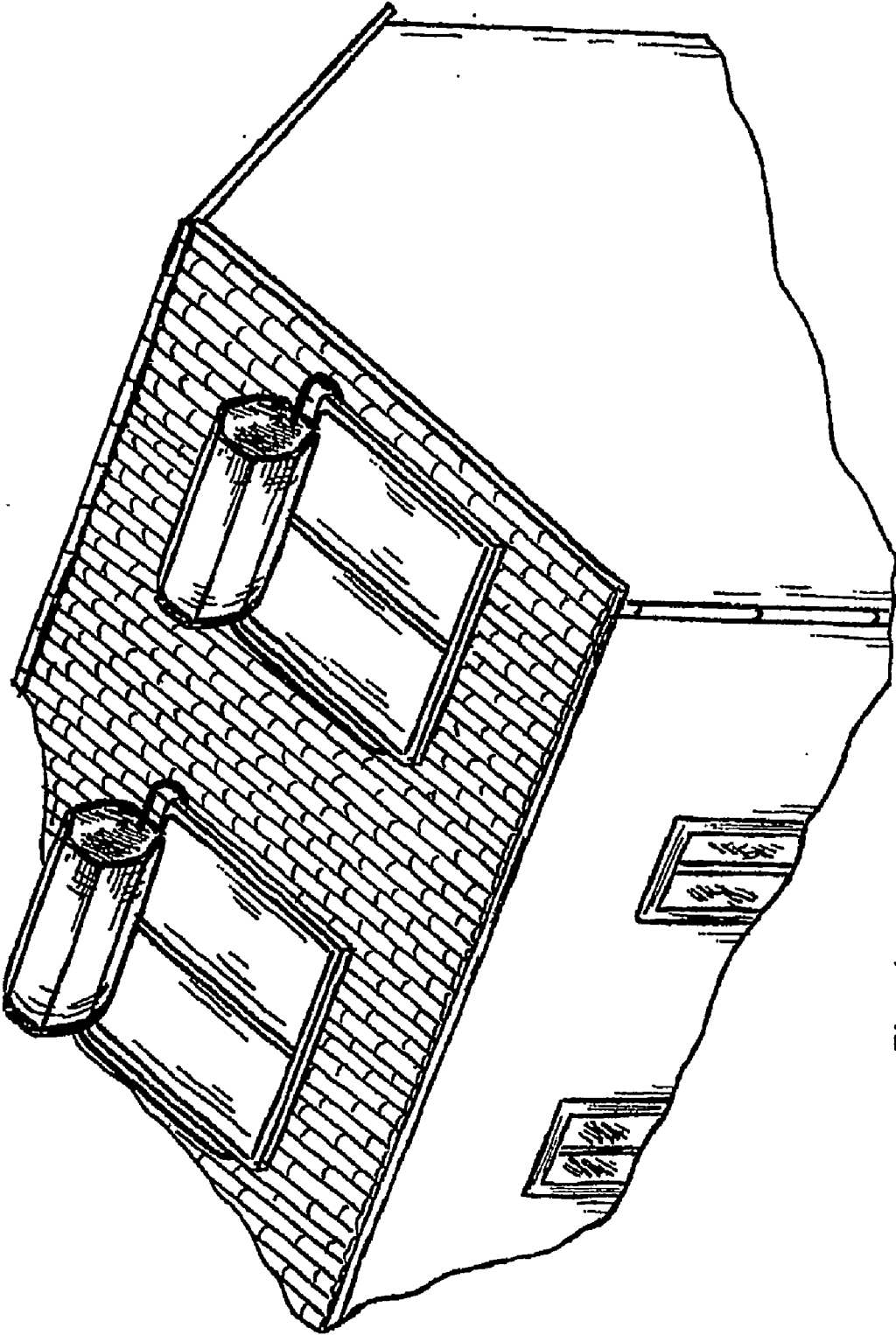

Fig. 1

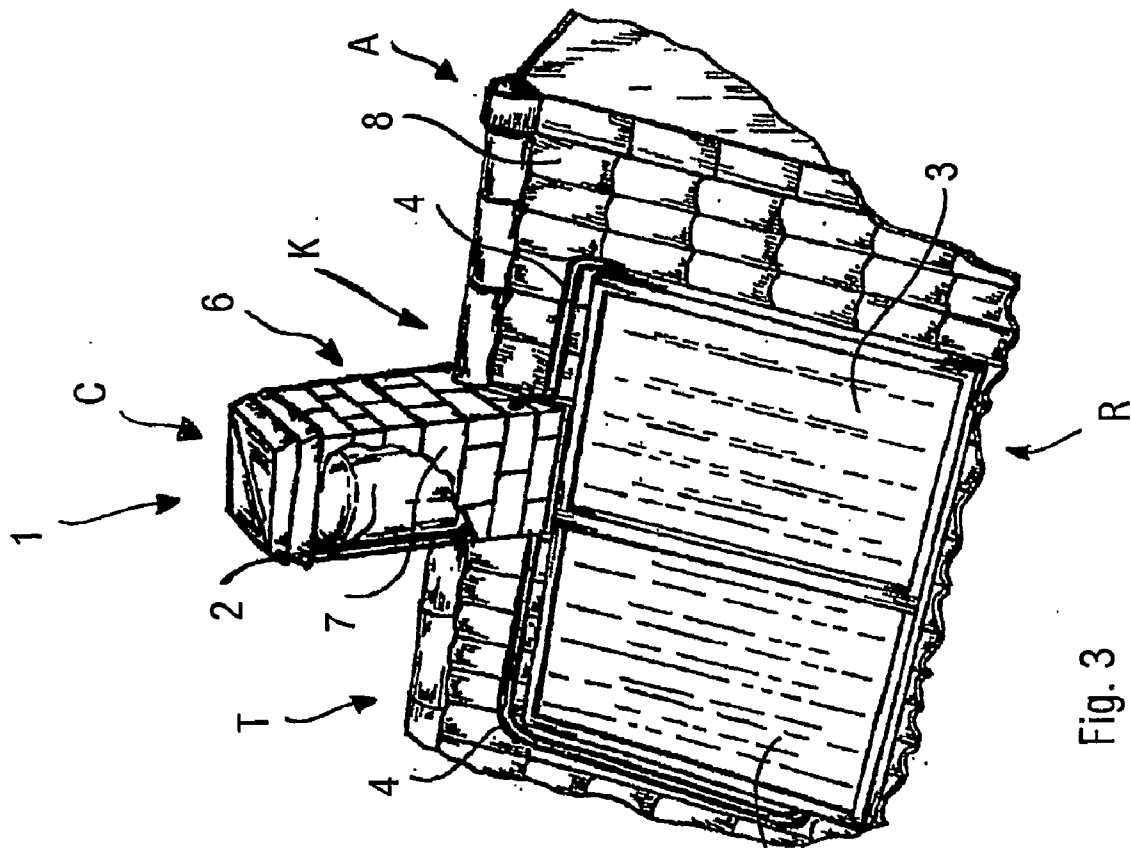

Fig. 3

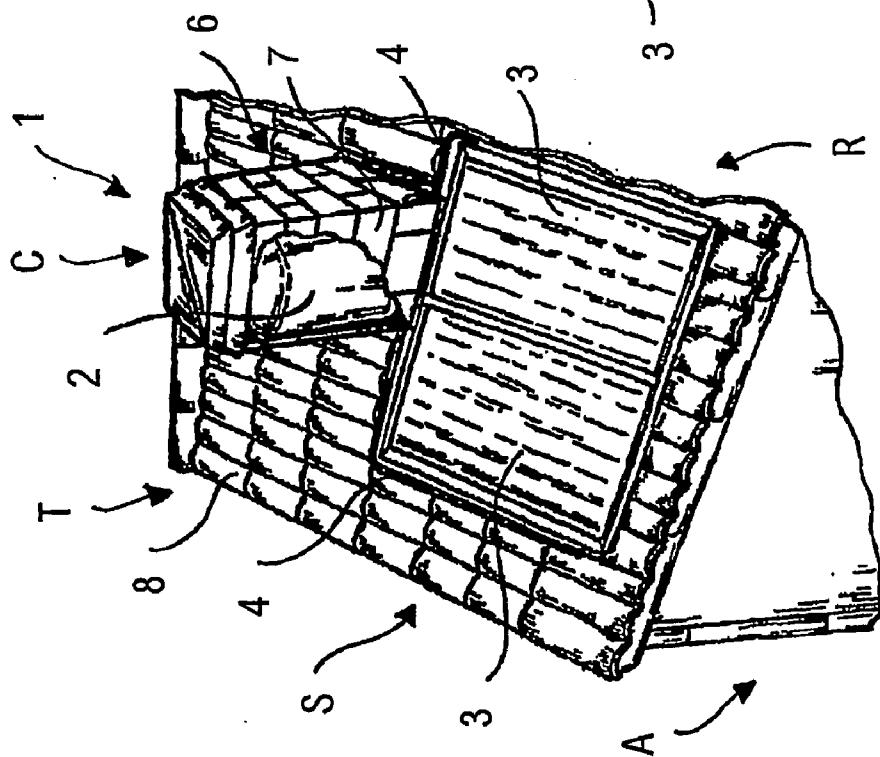

Fig. 2

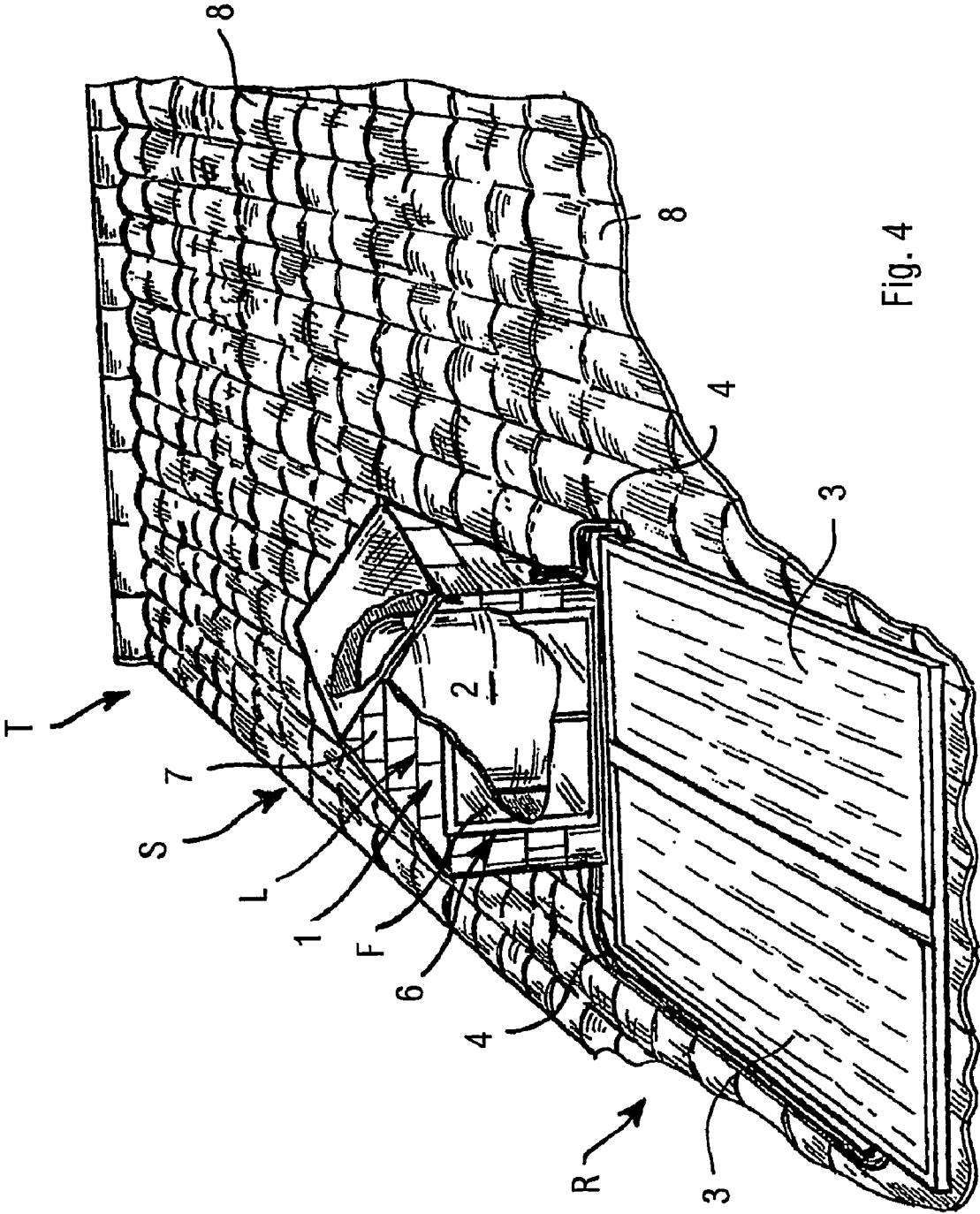
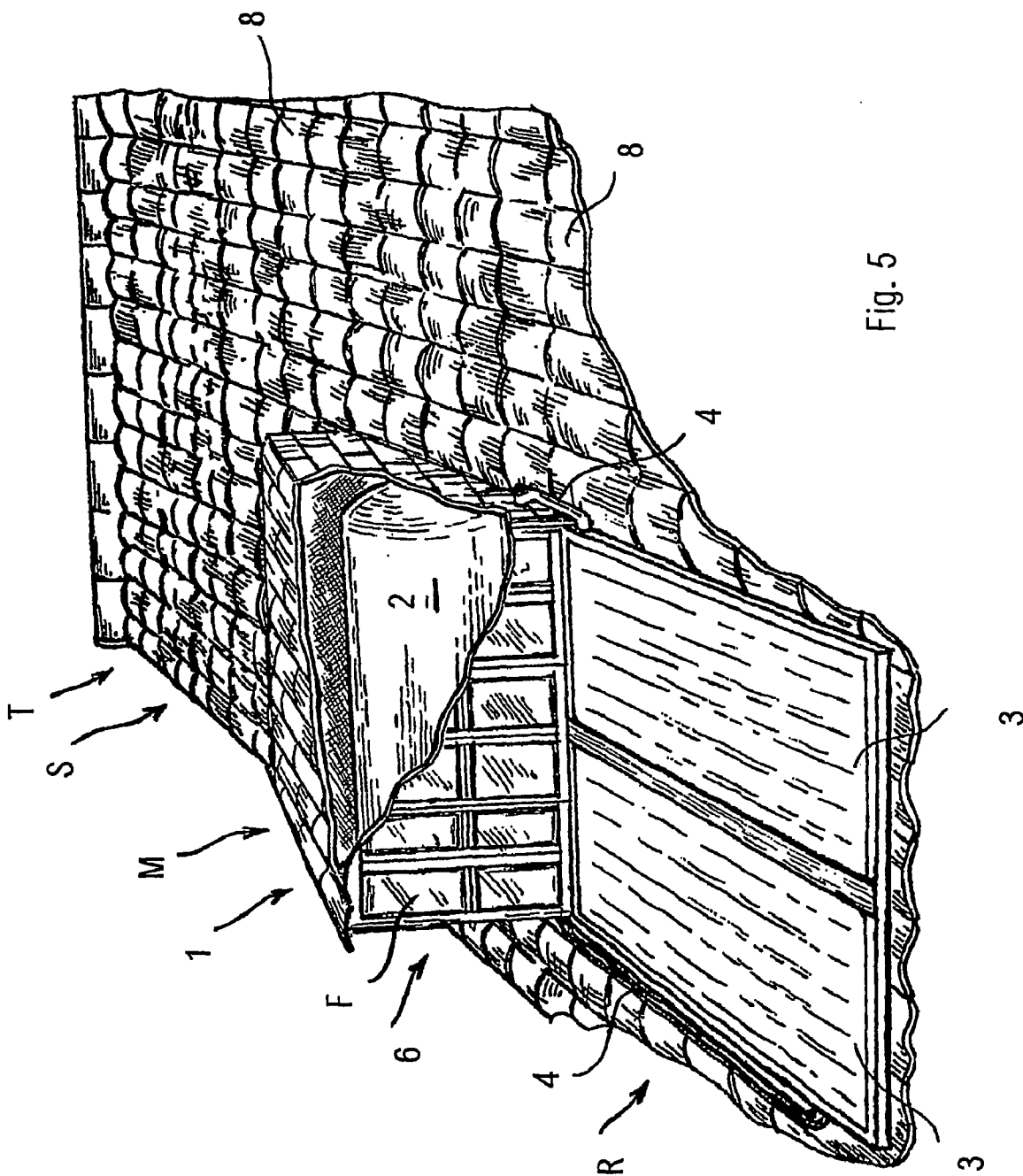

Fig. 4



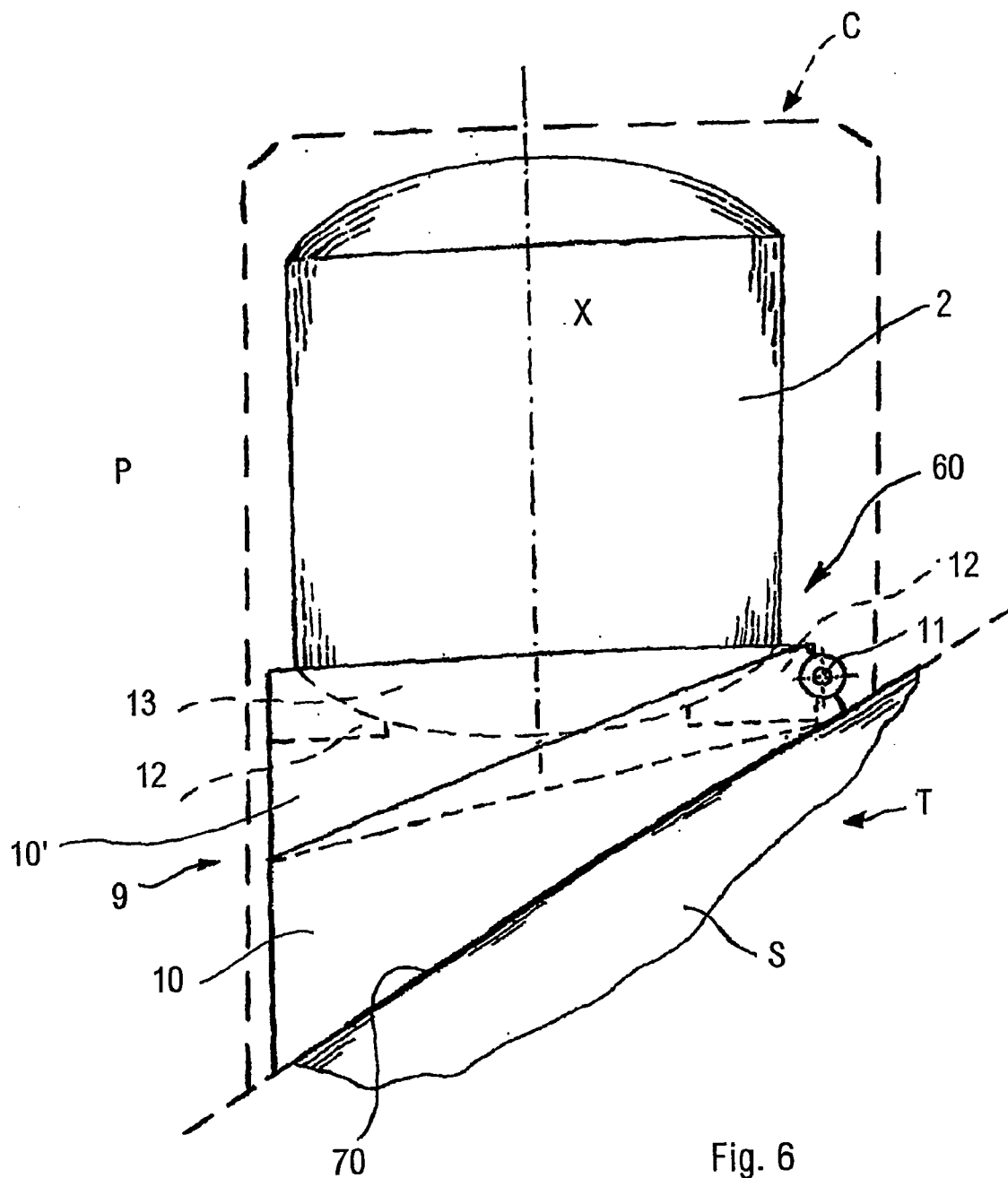

Fig. 6



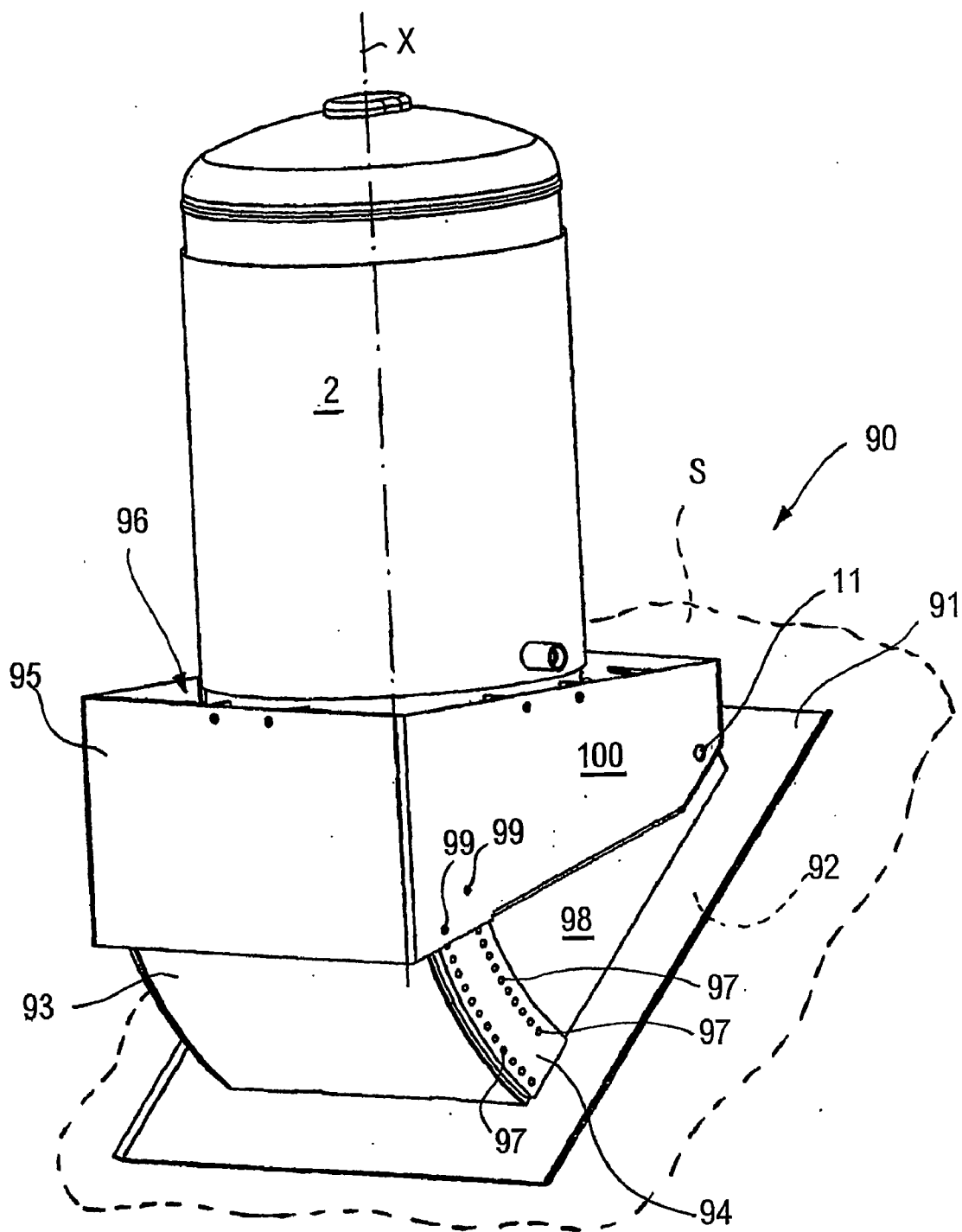

Fig. 9

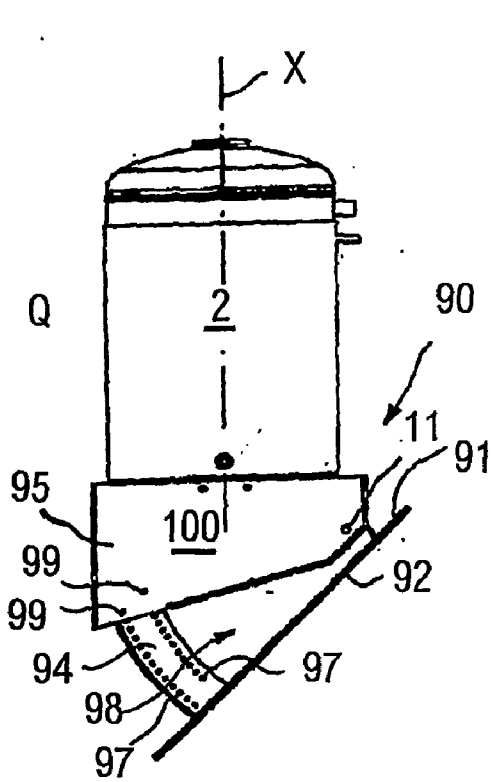

Fig. 10

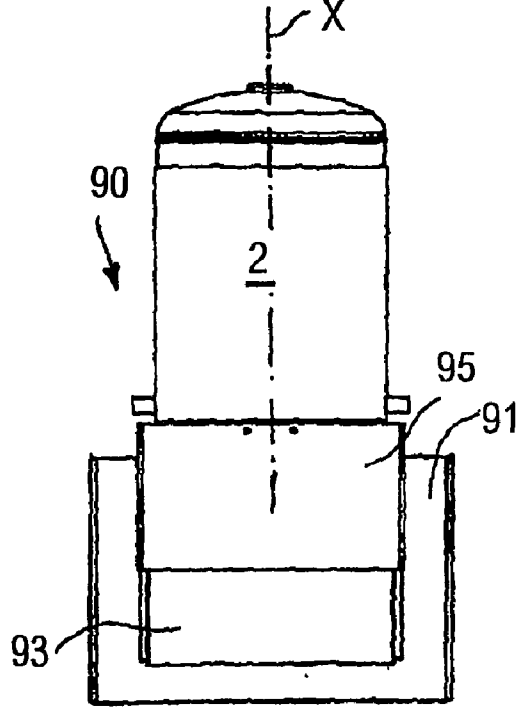

Fig. 11

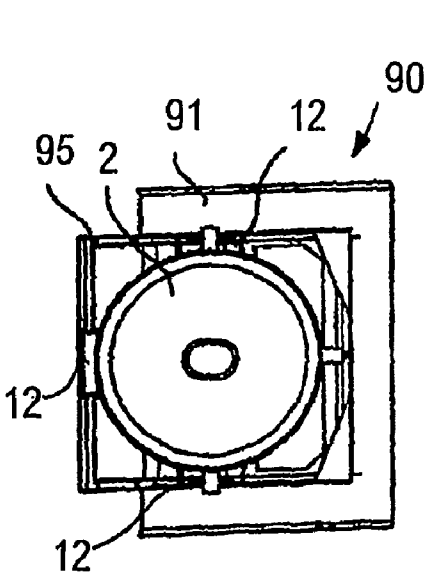

Fig. 13

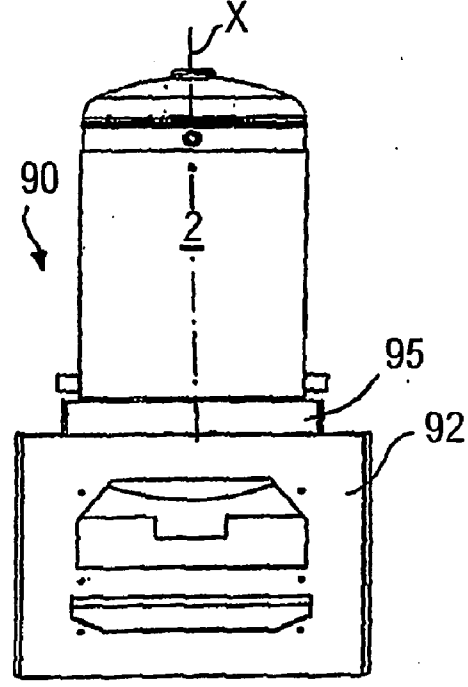

Fig. 12

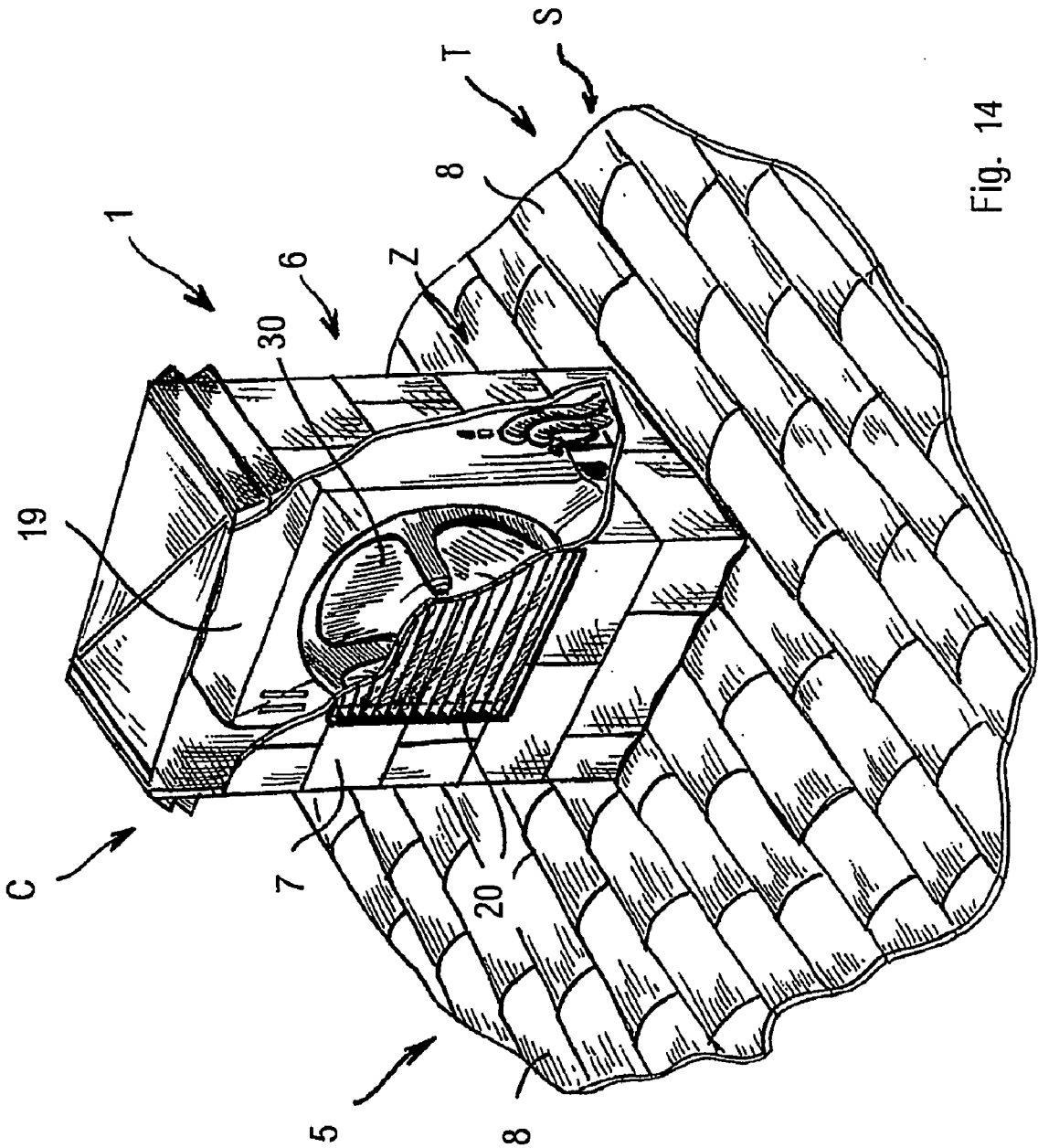

Fig. 14

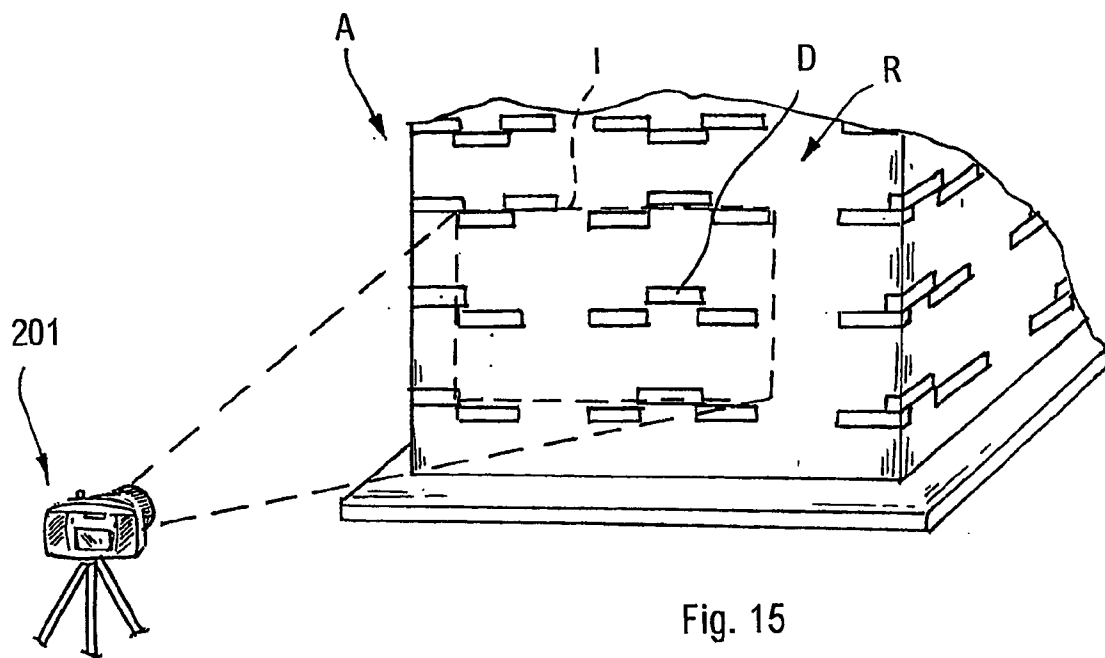

Fig. 15

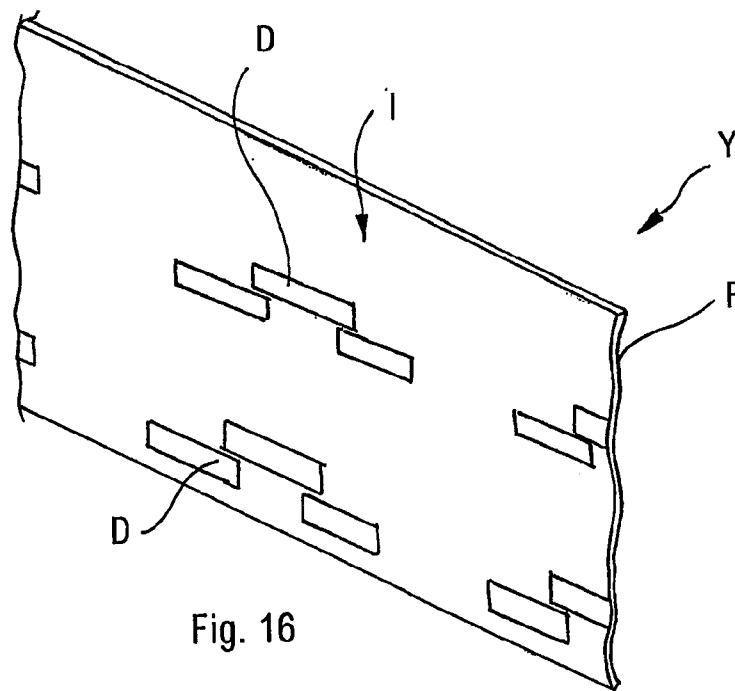

Fig. 16

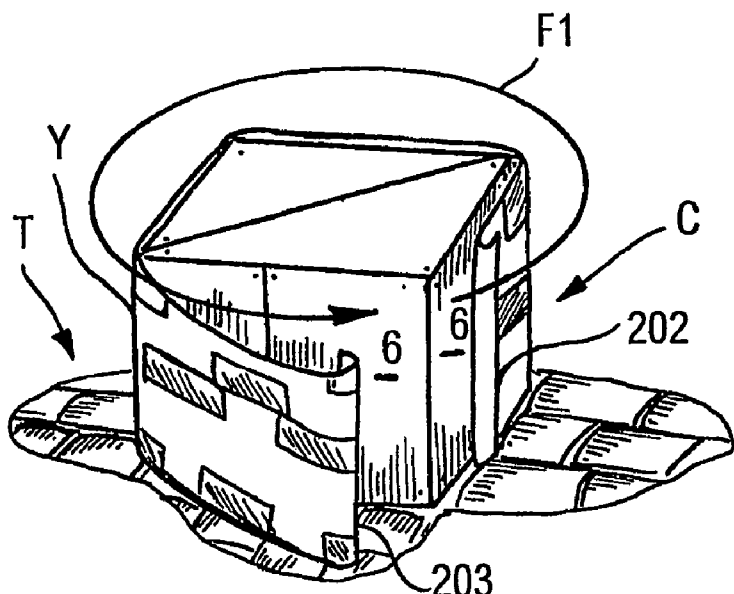

Fig. 17

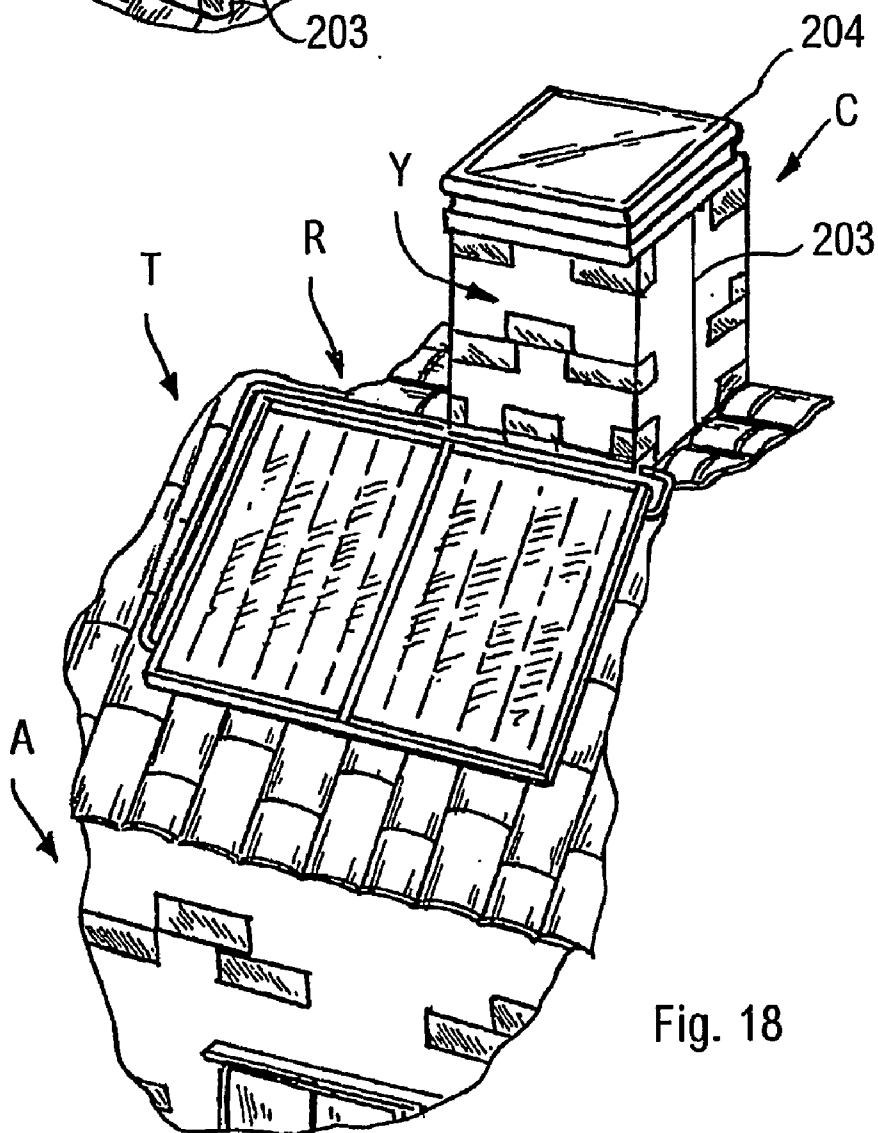

Fig. 18

**APPARATUS AND METHOD FOR INSTALLING  
FUNCTIONAL NON-ARCHITECTURAL  
ELEMENTS**

[0001] This invention concerns an apparatus for mounting and covering functional non-architectural elements on buildings, and in particular for mounting and covering an external water tank of a prior-art solar panel system to produce domestic hot water. Moreover, the invention concerns a method for aesthetically harmonising covering means of functional non-architectural elements with the buildings in which the latter are comprised. Solar panels are heat collectors suitable for transforming the solar electromagnetic energy directly in thermal energy and are mounted on the roofs of buildings or on other external portions of the latter wherein exposure to the solar radiation is at its maximum.

[0002] Each heat collector comprises an exchange circuit that extends as far as a tank containing water to be heated. In the exchange circuit, an exchange fluid (for example glycol) circulates that heats up in the heat collector due to the heat received from the solar radiation and cools around the walls of the tank, thus transferring heat to the water contained therein. Heat collectors also exist in the prior art wherein the water to be heated rather than the exchange fluid circulates directly.

[0003] To reduce the length of the connecting pipes placed between the heat collectors and the relative tanks, the latter are arranged on the roofs of the buildings as close as possible to the collectors, in a position that is immediately overhead in relation to the latter.

[0004] As a result, the tanks are installed in a position close to the ridge of the roof and are therefore rather visible, which is aesthetically unacceptable.

[0005] For this reason, the use of the solar panels of the type described above is still rare, despite the considerable advantages of such panels both in terms of protection of the CONFIRMATION COPY environment through their exploitation of solar energy and the considerable operational economy.

[0006] FR 2568990 and NL 1004031 disclose structures covering water tanks comprised in solar energy systems for producing domestic hot water. These structures are made in the shape of architectural elements, namely a prism-shaped canopy (FR 2568990) and an enlarged and modified ridge tile (NL 1004031). Both structures are only intended, and consequently shaped, for covering a water tank horizontally arranged onto a roof. Such functional elements, for example the external units of air-conditioning systems, are made aesthetically pleasing so that can increasingly be used in outer zones of residential buildings.

[0007] An object of this invention is to improve the apparatuses for mounting and covering functional elements that can be placed outside buildings.

[0008] Another object is to provide an apparatus for covering a water tank of a system producing domestic hot water by means of solar panels so as to hide the tank from view and simultaneously firmly anchor the tank to the roof of the relative building.

[0009] Another further object is to provide an apparatus for mounting on roofs functional non-architectural elements,

for example external units of air-conditioning systems, which enables the latter to be harmonised with the buildings.

[0010] A yet further object is to provide a substantially inexpensive and simple method for harmonising covering structures of functional non-architectural elements mounted on roofs of buildings with the architectural style of the buildings themselves.

[0011] According to a first aspect of the invention, there is provided apparatus, comprising covering means suitable for covering a water tank which can be mounted onto an external portion of a building, said covering means being made in the shape of an architectural component, characterized in that said apparatus further comprises angular positioning means so configured as to keep said tank in a substantially vertical position.

[0012] Owing to this aspect of the invention, it is possible to position the water tank in a substantially vertical position regardless of the slope of the portion of building onto which the tank has to be mounted. This is particularly useful when the water tank is comprised in a solar panel system for producing domestic hot water, since a vertical position of the tank ensures a more effective heat exchange, thus improving the efficiency of the solar panel system.

[0013] According to a second aspect of the invention, there is provided apparatus, comprising covering means suitable for covering a component of an air-conditioning system which can be mounted onto an external portion of a building, said covering means being made in the shape of an architectural component.

[0014] Owing to this aspect of the invention a functional element such as an external unit of an air-conditioning system can be installed outside a building in a way that is substantially harmonious with the aesthetic features of the latter.

[0015] According to a third aspect of the invention, there is provided a method, comprising:

[0016] reproducing a selected part of a building to get an image therefrom on layer means;

[0017] applying said onto support surface means surrounding a functional non-architectural element.

[0018] Owing to this aspect of the invention, it becomes possible to provide a covering structure, for example of a water tank or an external unit of an air-conditioning system, with the same architectural features of the building onto which the covering structure is mounted.

[0019] The invention may be better understood and carried into effect by referring to the enclosed drawings that show non-limiting embodiments, by way of examples, wherein:

[0020] FIG. 1 is an incomplete and fragmentary perspective view of an external arrangement of tanks of a solar-energy system for producing domestic hot water according to the prior art;

[0021] FIG. 2 is an incomplete, fragmentary and partially sectioned perspective view of an apparatus according to the invention;

[0022] FIG. 3 is an incomplete, fragmentary and partially sectioned perspective view of an apparatus according to the invention, in a further embodiment;

[0023] FIG. 4 is an incomplete, fragmentary and partially sectioned perspective view of an apparatus according to the invention, in an other further embodiment;

[0024] FIG. 5 is an incomplete, fragmentary and partially sectioned perspective view of an apparatus according to the invention, in an yet further other embodiment;

[0025] FIG. 6 is a schematic side view of the apparatus in FIG. 2, illustrating a constructional detail of the latter;

[0026] FIG. 7 is a schematic side view illustrating a further embodiment of the constructional detail of FIG. 6;

[0027] FIG. 8 is a schematic side view illustrating a further other embodiment of the constructional detail of FIG. 6;

[0028] FIG. 9 is a perspective view illustrating a yet further other embodiment of the constructional detail shown in FIG. 6;

[0029] FIG. 10 is a side view of the constructional detail shown in FIG. 9;

[0030] FIG. 11 is a front view of the constructional detail shown in FIG. 10;

[0031] FIG. 12 is a rear view of the constructional detail shown in FIG. 10;

[0032] FIG. 13 is a plan view of the constructional detail shown in FIG. 10;

[0033] FIG. 14 is an incomplete, fragmentary and partially sectioned perspective view illustrating a further other embodiment of the apparatus according to the invention;

[0034] FIG. 15 is a schematic perspective, fragmentary and incomplete view illustrating a step of a method according to the invention;

[0035] FIG. 16 is a schematic perspective view illustrating an other step of the method according to the invention;

[0036] FIG. 17 is a schematic perspective, fragmentary and incomplete view illustrating a further step of the method according to the invention;

[0037] FIG. 18 is a schematic perspective, fragmentary and incomplete view illustrating a yet further step of the method according to the invention;

[0038] In FIGS. 2 to 5, on a tiled 8 roof T of a house A a mounting and covering apparatus 1 of a tank 2 comprised in a prior-art solar panel system R producing domestic hot water to be supplied to the house A. The tank 2 is arranged to contain the water to be heated and the latter is fed by means of conduits 4 to a pair of prior-art heat collectors 3 comprising a pipe with a helical or coiled configuration that is not shown.

[0039] The apparatus 1 located on the roof T immediately above the collectors 3 may have the shape of a chimney cap C, skylight L or attic skylight M, and is defined by a plurality of walls 6. Each wall 6 consists of one or more panel elements 7, made for example of fibreglass, A.B.S., polycarbonate, polystyrene, sheet metal, or another material that resists atmospheric agents, the visible faces of which are decorated and/or shaped in such a way as to imitate prior-art building bricks. In particular, the panel elements 7 can be made in such a way as to reproduce the ornamental features

of the external walls of the house A or of the roof tiles 8. In an embodiment that is not shown, the walls 6 are also made from prior-art building bricks

[0040] By suitably making the walls 6 of the apparatus 1 in the shape of a chimney cap C the latter can be installed on a sloping part S or a ridge K of the roof T.

[0041] In the apparatus 1 made in the shape of a skylight L and/or in the shape of an attic skylight M one of the walls 6 comprises a real or simulated window F, made in harmony with the aesthetic features of the house A.

[0042] When the apparatus 1 is shaped like a chimney cap C or a skylight L, in the latter the tank 2 is kept in a vertical position by means of fixing means described below. When the apparatus 1 is shaped like an attic skylight M, the tank 2 is spread horizontally and is fixed to the roof T with prior-art fixing means that is not shown.

[0043] In FIG. 6, the tank 2, accommodated inside the apparatus 1 made in the shape of a chimney cap C, is stably positioned by angular positioning means comprising an adjustable angular positioning element 9, having a quadrilateral shape and comprising a hollow base portion 10 that is made integral with the sloping part S of the roof T by means of prior-art fixing means, that are not shown. On the base portion 10 a movable portion 10' is hinged by means of a hinge 11, said movable portion 10' having a shape and dimensions such as it can be retractably inserted inside said base portion 10. The movable portion 10' furthermore comprises a circular opening 60, arranged horizontally to receive a generally convex end portion 13 of the tank 2. Inside the movable portion 10', concave stop elements 12 are inserted that are arranged to receive the end portion 13.

[0044] In use, after fixing an anchoring base face 70 of the base portion 10 to the sloping part S, the movable portion 10' is made to rotate on the hinge 11 until it reaches a desired position P, wherein the movable portion 10' is orthogonal as regards a longitudinal axis X of the tank 2. The latter can then be inserted into the movable portion 10' with the end portion 13 resting on the stop elements 12. In this way, the longitudinal axis X of the tank 2 can be kept vertical regardless of the angle of inclination of the sloping part S. The adjustable angular positioning element 9 can also be used for the apparatus 1 made in the shape of a skylight L.

[0045] Note that the structure of the above disclosed angular positioning means enables a tank 2 to be mounted on sloping parts S that have inclinations comprised within a wide range of values.

[0046] In FIG. 7, a further adjustable angular positioning element 14 is provided that is arranged to stably position the tank 2 accommodated in the apparatus 1 in the shape of a chimney cap C, on the ridge K of the roof T. The further adjustable angular positioning element 14 comprises a pair of further movable portions 15, 15' between which a hollow support portion 16 is comprised. The support portion 16 has dimensions that enable it to be retractably housed into the further movable portions 15, 15' and furthermore comprises a circular opening 50, arranged horizontally to receive the end portion 13 of the tank 2. Inside the support portion 16 stop elements 12 are arranged that are shapingly coupled with the end portion 13.

[0047] The further movable portions 15, 15' are hinged on the support portion 16 by means of relative hinges 11, the

axes of which run parallel in an approximately middle portion of the support portion 16. In this way, the further movable portions 15, 15' are set in mutually opposite directions.

[0048] In use, after horizontally positioning the support portion 16 of the further adjustable angular positioning element 14 straddling the ridge K, the further movable portions 15, 15' are made to rotate until a further base anchoring face 80, 80' of the latter is brought into contact with the respective opposite sloping parts S, S'. In this way, the further adjustable angular positioning element 14 can be adapted to the width of an angle H of the ridge K, so as to enable the support portion 16 to take up a horizontal position and thus keeping the longitudinal axis X of the tank 2 in a vertical position.

[0049] The further adjustable portions 15, 15' are then made integral with the sloping parts S, S' by prior-art fixing means that are not shown and the tank 2 is inserted into the support portion 16, with the end portion 13 resting on the stop elements 12.

[0050] FIGS. 9 to 13 show a yet further adjustable angular positioning element 90, that is arranged to stably position the tank 2 accommodated in the apparatus 1 in the shape of a chimney cap (not shown). The further adjustable angular positioning element 90 comprises a substantially rectangle-shaped anchoring plate 91 whose further anchoring base face 92 can be fixed to the sloping part S, shown by means of a broken line.

[0051] A further base portion 93 leads away from an approximately central portion of the anchoring plate 91, said further base portion 93 having a longitudinal section that is substantially shaped as a circular sector. In two opposite side faces 98 of the further base portion 93 a curved plate 94 is provided, in which a plurality of holes 97 is obtained. A yet further movable portion 95 is hinged to the further base portion 93 by means of a hinge 11, said yet further movable portion 95 having a shape and dimensions that enable it, when rotating along the hinge 11, to partially cover the further base portion 93. In two opposite further side faces 100 of the yet further movable portion 95 further holes 99 are obtained, which are level with the holes 97 of the further base portion 93. The yet further movable portion 95 furthermore comprises a square opening 96, arranged horizontally to receive an end portion, not shown, of the tank 2. Inside the yet further movable portion 95, concave stop elements 12 are inserted that are arranged to receive the end portion.

[0052] In use, after fixing the further anchoring base face 92 of the anchoring plate 91 to the sloping part S by means of prior art fixing means, that is not shown, the yet further movable portion 95 is made to rotate on the hinge 11 until it reaches a desired position Q, wherein the yet further movable portion 95 is at right angles to the longitudinal axis X of the tank 2. The position Q, once reached, can be kept by inserting prior art fixing means, that is not shown, through the further holes 99 and the corresponding holes 97.

[0053] The tank 2 can then be inserted into the yet further movable portion 95 with the end portion resting on the stop elements 12. In this way, the longitudinal axis X of the tank 2 can be kept vertical regardless of the angle of inclination of the sloping part S.

[0054] In FIG. 8 a fixed angular positioning element 17 is provided, usable to stably position on the sloping part S the

tank 2 accommodated in the apparatus 1 made in the shape of a chimney cap C or a skylight L. The fixed angular positioning element 17 is made in the shape of a quadrilateral having a triangular longitudinal section and a circular opening 40 arranged horizontally to accommodate the end portion 13. In use, a base face 18 of the fixed angular positioning element 17 opposite the circular opening is made integral with the sloping part S by prior-art fixing means that are not shown. The end portion 13 is then inserted in the circular opening 40 and is rotated in the latter until the tank 2 reaches a position wherein the longitudinal axis X of the latter is arranged vertically.

[0055] It is pointed out that the vertical attitude of the tank 2 which is obtainable through the angular positioning elements (9; 14; 17; 90) shown in FIGS. 6-13 enables a more effective heat exchange to be achieved.

[0056] As shown in FIG. 14, also a non-architectural functional element other than the tank 2, for example an external unit 19 of an air-conditioning system Z, can be housed inside the apparatus 1. The external unit 19, made integral with the sloping part S by means of prior-art fixing means, that is not shown, is accommodated inside the apparatus 1 made for example in the shape of a chimney cap C. In the latter, walls 6 that are opposite one another and are situated near a fan 30 of the external unit 19 each comprise a grille 20 for enabling air to be taken from the external environment. In an alternative embodiment, that is not shown, intended for external units of air-conditioning systems provided with fans having a vertically arranged axis, the apparatus 1 can be made in the shape of a chimney cap C having an open top end, which may be provided with a grille. In this way it is for example possible to provide an air-conditioning system for buildings subject to artistic protective constraints and which cannot therefore accommodate external structures that are aesthetically disturbing.

[0057] The apparatus 1 may furthermore be made, in addition to the described forms of chimney cap C, skylight L and attic skylight M, also in the form of further architectural components, for example verandas or balconies, that are not shown or disclosed in detail, that are selected on the basis of the dimensions and contour of the non-architectural functional elements to be installed on the outside of buildings.

[0058] FIGS. 15 and 16 show a well-known device, for example a camera 201, by means of which a picture I, shown by means of a broken line, is obtained from a front portion R of a house A. The picture I can be taken so as to portray, for example, a decorative pattern D comprised in the house A. Once obtained, the picture I can be transferred, by means of prior art techniques that are not disclosed in detail, onto a supporting film F, for example made from plastics, thus forming a covering layer Y.

[0059] FIGS. 17 and 18 show a procedure for fitting the covering layer Y onto a covering structure installed on a roof T, said covering structure housing a water tank (not shown) comprised in a solar panel system R for producing domestic hot water. The covering structure, for example, is the above disclosed apparatus 1 made in the shape of the chimney cap C.

[0060] The covering layer Y, whose shape and dimensions are selected so as to fully wrap the walls 6 of the chimney

cap C, is wound around the latter according a rotatory verse shown by the arrow F1, so as to enable two curved edges 202, 203, obtained in opposite ends of the covering layer Y, to mutually come into contact. Once the edges 202, 203 have been made to reciprocally engage, a prior art top element 204 is applied onto the chimney cap C, thus ensuring the covering layer Y to be firmly blocked thereon. In a further embodiment, not shown, the face of the covering layer Y opposite the picture I is provided with an adhesive layer, which can be fixed to the walls of a covering structure.

[0061] The disclosed method becomes very useful when the house A is an ancient one, which makes significantly difficult and/or expensive manufacturing covering structures according to the architectural style and/or the aged appearance of the house.

[0062] The above disclosures show that the apparatus 1 provided by the invention in all its possible architectural embodiments is always includable in a building and is therefore suitable for housing a non-architectural functional element, such as for example a water tank or an external unit of an air-conditioning system, making the latter aesthetically harmonised with the building for which it is intended. This enables the significant aesthetic damage to be avoided that is for example produced by the water tanks of solar panels systems mounted on the roofs of buildings provided for by the state of the art illustrated in FIG. 1.

[0063] Moreover, according to the method provided by the invention, it becomes possible to harmonise any kind of covering means of non-architectural elements with the building onto which the elements, and the respective covering means, are mounted. This result can be achieved by reproducing onto the covering means, in a substantially inexpensive manner, the architectural style occurring in the respective building.

1-34. (canceled)

35. Apparatus, comprising a covering arrangement suitable for covering a water tank which can be mounted onto an external portion of a building, said covering arrangement being made in the shape of an architectural component, wherein said apparatus further comprises an angular positioning device so configured as to keep said tank in a substantially vertical position.

36. Apparatus according to claim 35, wherein said water container is a component of a solar panel system.

37. Apparatus according to claim 35, wherein said angular positioning device comprises a seat arranged for housing said tank therein, and an anchoring element for anchoring to said external portion.

38. Apparatus according to claim 37, wherein said seat and said anchoring element are obtained in opposite portions of a positioning shell element.

39. Apparatus according to claim 38, wherein said seat is obtained in a first positioning shell element.

40. Apparatus according to claim 39, wherein said anchoring element is obtained in a second positioning shell element hinged on said first positioning shell element.

41. Apparatus according to claim 40, wherein said seat is shaped in such a way that a longitudinal axis of said tank can be arranged vertically by rotating said first positioning shell element in relation to said second positioning shell element.

42. Apparatus, comprising a covering arrangement suitable for covering a component of an air-conditioning system

which can be mounted onto an external portion of a building, said covering arrangement being made in the shape of an architectural component.

43. Apparatus according to claim 42, further comprising an angular positioning device such as to keep said component in a substantially vertical position.

44. Apparatus according to claim 43, wherein said angular positioning device comprises a seat arranged for housing said component therein, and an anchoring element for anchoring to said external portion of said building.

45. Apparatus according to claim 44, wherein said seat and said anchoring element are obtained in opposite portions of a positioning shell element.

46. Apparatus according to claim 45, wherein said seat is obtained in first positioning shell element.

47. Apparatus according to claim 46, wherein said anchoring element is obtained in a second positioning shell element hinged on said first positioning shell element.

48. Apparatus according to claims 47, wherein said seat is shaped in such a way that a longitudinal axis of said tank can be arranged vertically by rotating said first positioning shell element in relation to said second positioning shell element.

49. Apparatus according to claim 35, wherein said external portion comprises a roof.

50. Apparatus according to claim 35, wherein said architectural component has a shape selected from a group comprising: chimney cap, skylight, attic skylight, veranda, balcony, column, arch.

51. Apparatus according to claim 35, wherein said covering arrangement comprises a wall arrangement.

52. Apparatus according to claim 51, wherein said wall arrangement furthermore comprises a window.

53. Apparatus according to claim 51, wherein said wall arrangement furthermore comprises a grille.

54. Apparatus according to claim 51, wherein said wall arrangement is made of building bricks.

55. Apparatus according to claim 51, wherein said wall arrangement is made of panel elements.

56. Apparatus according to claim 55, wherein said panel elements are made of a material that resists atmospheric agents.

57. Apparatus according to claim 56, wherein said material that resists atmospheric agents is selected from a group comprising: glass fibre, A.B.S., polycarbonate, polystyrene, sheet metal.

58. Method, comprising: reproducing a selected part of a building to get an image therefrom on a layer element; applying said layer element onto a supporting surface element surrounding a functional non-architectural element.

59. Method according to claim 58, wherein said supporting surface element is part of a covering arrangement enclosing said functional non-architectural element.

60. Method according to claim 58, wherein said supporting surface element is comprised in an external surface of said functional non-architectural element.

61. Method according to claim 58, wherein said image is obtained by using a photographic device.

62. Method according to claim 58, wherein said image is transferred onto a supporting film, so as to form a covering layer.

63. Method according to claim 58, wherein said applying comprises winding said layer element around a covering arrangement housing said functional non-architectural element.

64. Method according to claim 63, wherein said applying comprises mutually engaging opposite curved edges of said layer element.

65. Method according to claim 58, wherein said covering arrangement takes part of an apparatus according to claim 50.

66. Method according to claim 58, wherein said functional non-architectural element comprises a water tank.

67. Method according to claim 66, wherein said water tank is comprised in a solar panel system.

68. Method according to claim 58, wherein said functional non-architectural element comprises a component of an air-conditioning system.

\* \* \* \* \*