



US 20060191546A1

(19) **United States**

(12) **Patent Application Publication** (10) **Pub. No.: US 2006/0191546 A1**

Takano et al. (43) **Pub. Date: Aug. 31, 2006**

(54) **NICOTINE SUCTION PIPE AND NICOTINE HOLDER** Sep. 26, 2003 (JP) 2003-335906
Feb. 20, 2004 (JP) 2004-044225

(76) Inventors: **Shusei Takano**, Toyama-shi (JP); **Daiju Takano**, Toyama-shi (JP)

Publication Classification

(51) **Int. Cl.**
A24F 47/00 (2006.01)
(52) **U.S. Cl.** 131/270

Correspondence Address:
BIRCH STEWART KOLASCH & BIRCH
PO BOX 747
FALLS CHURCH, VA 22040-0747 (US)

(57) **ABSTRACT**

A nicotine inhalation pipe includes a rodlike nicotine holder (1) and a mouthpiece (2) attached to one end of the holder (1). The holder (1) includes a transparent outer tube (3) having a plurality of openings (36) at both ends thereof, liquid absorbent granules (34) filled in the outer tube (3), and a nicotine inhalation path formed by gaps between the liquid absorbent granules (34) and gaps between the inner peripheral surface of the outer tube (3) and the liquid absorbent granules (34). The liquid absorbent granules (34), which are made of porous silica gel and in which a nicotine solution is absorbed, permit nicotine to be vaporized from the nicotine solution.

(21) Appl. No.: **10/551,644**

(22) PCT Filed: **Mar. 30, 2004**

(86) PCT No.: **PCT/JP04/04528**

(30) **Foreign Application Priority Data**

Apr. 1, 2003 (JP) 2003-097603
Jul. 14, 2003 (JP) 2003-196457

FIG. 1

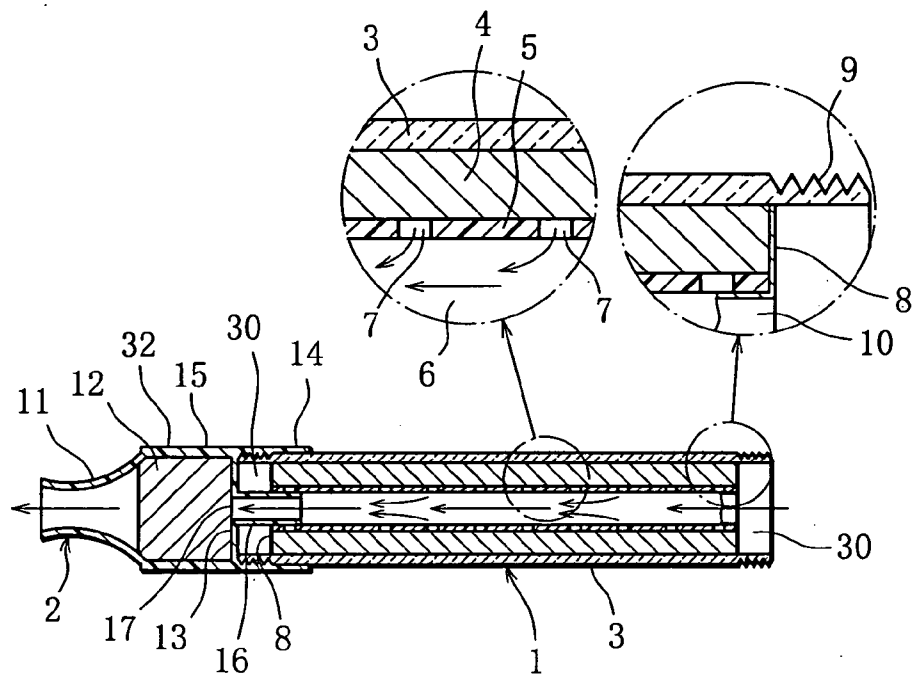

FIG. 2

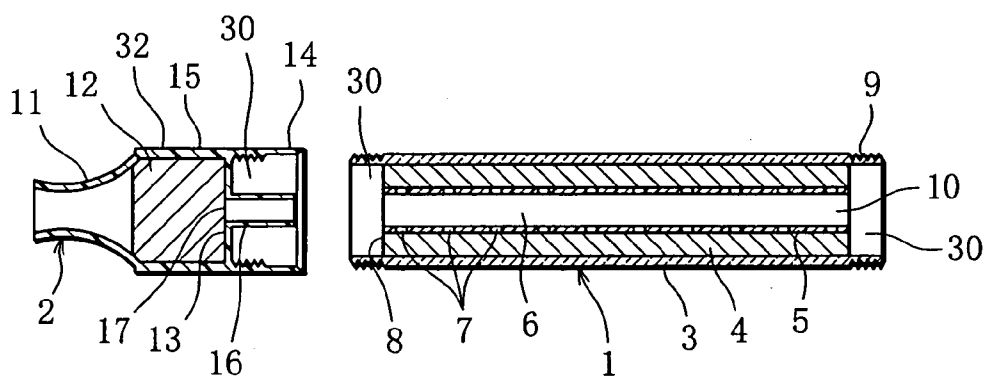

FIG. 3

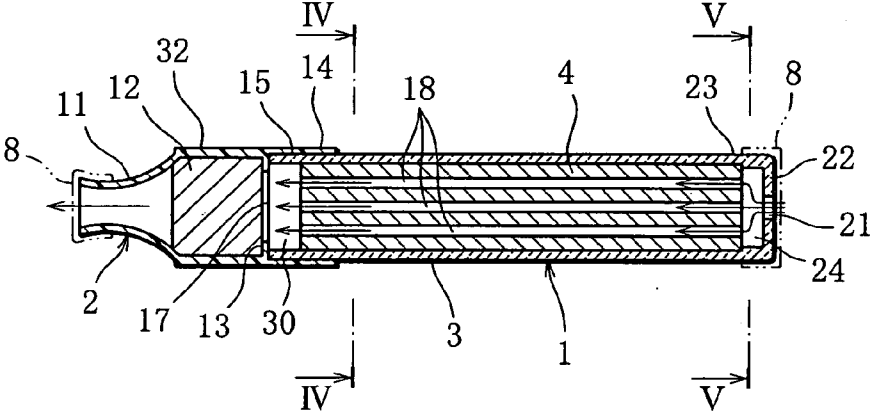

FIG. 4

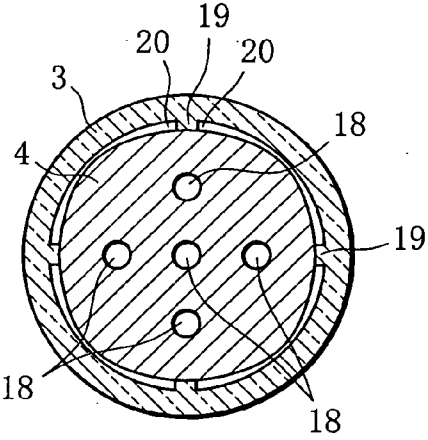

FIG. 5

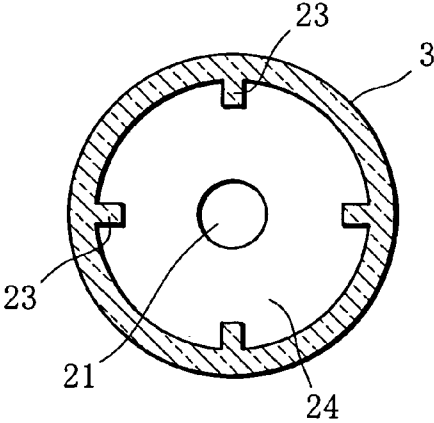

FIG. 6

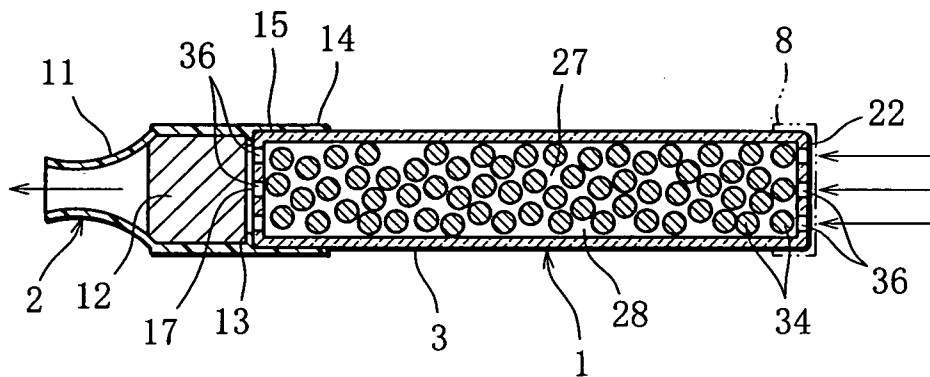
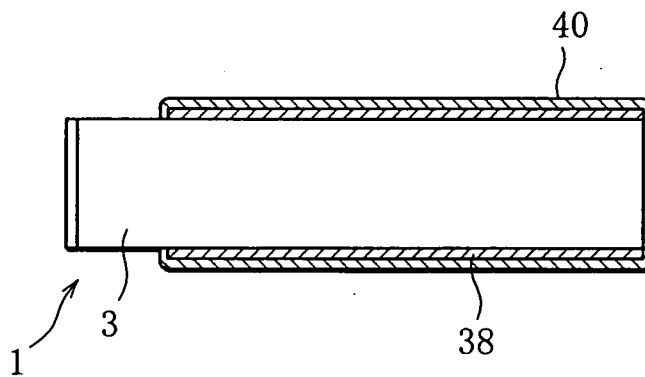

FIG. 7



NICOTINE SUCTION PIPE AND NICOTINE HOLDER

TECHNICAL FIELD

[0001] The present invention relates to a nicotine inhalation pipe and a nicotine holder containing a nicotine solution. More particularly, the present invention relates to a pipe which allows nicotine vaporized from a nicotine solution to be inhaled together with air and a holder containing a nicotine solution.

BACKGROUND ART

[0002] Smoking articles such as cigarettes and cigars produce smoke containing nicotine, namely, main-stream smoke, when tobacco therein is burned. Smokers inhale the main-stream smoke and thereby take in nicotine contained in the main-stream smoke. Apart from such smoking articles smoked in an ordinary way, there are known articles which allow nicotine to be taken in without producing smoke, such as chewing gum containing nicotine and sheetlike adhesive plaster applied with a nicotine-containing substance.

[0003] However, such chewing gum and adhesive plaster need not be puffed, unlike cigarettes and cigars, and thus are unable to give consumers a feeling of release or satisfaction that is created by the act of puffing.

[0004] Accordingly, there has been a demand for a nicotine inhalation pipe which allows nicotine to be taken in by being puffed, like smoking articles such as cigarettes and cigars, but without producing smoke.

[0005] An inhalation pipe disclosed in Unexamined Japanese Patent Publication No. H06-114105, for example, has a hollow shank capable of receiving a cigarette or a filter cigarette and having a mouthpiece at one end thereof. A bowl with a cap is connected to the other end of the shank and the cap has a ventilation hole therein. Further, an electric heater and hydrophilic fibers containing water are arranged inside the bowl.

[0006] As the air in the inhalation pipe is sucked by a consumer through the mouthpiece, the outside air is introduced into the bowl through the ventilation hole in the cap. The introduced air is humidified when passing through the hydrophilic fibers and then is heated by the electric heater. When passing through the filter cigarette thereafter, the high-temperature moist air heats the filter cigarette. Consequently, nicotine and aromatics vaporize from the shredded tobacco in the filter cigarette, and the vaporized nicotine and aromatics are inhaled by the consumer together with the moist air.

[0007] When the consumer sucks in air from the inhalation pipe, the outside air passes through the hydrophilic fibers containing water and the moist air produced in the bowl then passes through the filter cigarette. Accordingly, the inhalation resistance of the inhalation pipe is extremely large, compared with filter cigarettes, and the consumer cannot inhale nicotine and aromatics with ease.

[0008] Also, because of the bowl, the inhalation pipe has an external form significantly different from those of rodlike smoking articles such as cigarettes and cigars. Compared with rodlike smoking articles, therefore, the inhalation pipe is too cumbersome to carry or to keep and is not easy to handle.

DISCLOSURE OF THE INVENTION

[0009] An object of the present invention is to provide a smokeless nicotine inhalation pipe with small inhalation resistance which allows nicotine to be taken in by being puffed, like rodlike smoking articles such as cigarettes and cigars, and which also has a rodlike external form similar to those of the smoking articles, and a nicotine holder for the nicotine inhalation pipe.

[0010] To achieve the object, a nicotine inhalation pipe according to the present invention comprises: a rodlike outer tube opening at both ends; a nicotine generator arranged inside the outer tube, the nicotine generator including a liquid absorbent in which a nicotine solution is absorbed and which permits nicotine to be vaporized from the nicotine solution, and a nicotine inhalation path extending substantially through the nicotine generator in an axial direction of the outer tube and distinctly separated from the liquid absorbent; and a mouthpiece attached to one end of the outer tube.

[0011] When the nicotine inhalation pipe is puffed, a negative pressure is created within the outer tube and air is introduced into the outer tube from outside. The negative pressure created in the outer tube promotes vaporization of nicotine from the nicotine solution in the liquid absorbent and the vaporized nicotine flows into a consumer's mouth together with the introduced air.

[0012] Thus, the consumer takes in nicotine by inhaling through the inhalation pipe, that is, by puffing, and therefore can enjoy a feeling of satisfaction similar to that experienced when smoking a filter cigarette or a cigar.

[0013] Also, the nicotine inhalation path in the inhalation pipe is distinctly separated from the liquid absorbent, and thus the inhalation resistance of the inhalation pipe is small. Moreover, the inhalation pipe itself is in the form of a rod, so that the consumer can experience a feeling as if he/she were smoking a filter cigarette or a cigar.

[0014] Further, the inhalation pipe does not produce smoke and thus is free from inconveniences caused by smoke, making it possible for the consumer to take in nicotine even in a non-smoking area.

[0015] The mouthpiece may either be detachable from the nicotine holder or be integrally coupled with the nicotine holder.

[0016] The nicotine solution may be either a solution prepared by dissolving only nicotine in a solvent or a solution containing nicotine as well as other additives.

[0017] Specifically, the nicotine generator may further include an inner tube arranged inside the outer tube coaxially therewith such that the liquid absorbent is held between the inner and outer tubes, the inner tube having an interior forming the nicotine inhalation path; and a large number of small holes formed in the inner tube and allowing nicotine to vaporize from the nicotine solution of the liquid absorbent into the interior of the inner tube. The vaporized nicotine flows into the consumer's mouth together with the air introduced into the inner tube.

[0018] The liquid absorbent may have a cylindrical form extending through the outer tube and having an outside diameter nearly equal to the inside diameter of the outer

tube. In this case, the nicotine inhalation path may include a plurality of axial passages extending through the liquid absorbent in the axial direction of the outer tube. Nicotine vaporizes from the nicotine solution of the liquid absorbent into the axial passages, and the vaporized nicotine flows into the consumer's mouth together with the air introduced into the axial passages.

[0019] The inhalation pipe may further comprise an outer axial passage defined between the inner peripheral surface of the outer tube and the outer peripheral surface of the cylindrical liquid absorbent. The outer axial passage is secured by a rib or a groove formed on one of the inner peripheral surface of the outer tube and the outer peripheral surface of the liquid absorbent and extending in the axial direction of the outer tube. In this case, nicotine vaporized from the outer peripheral surface of the liquid absorbent flows into the consumer's mouth through the outer axial passage together with the air introduced therein.

[0020] Further, the outer tube of the inhalation pipe may have end walls at respective opposite ends thereof, each end wall having an opening. In this case, the liquid absorbent comprises porous granules filled in the outer tube and having a diameter larger than that of the openings, and the nicotine inhalation path is formed by gaps between the granules and gaps between the inner peripheral surface of the outer tube and the granules.

[0021] With this inhalation pipe, the outer tube can be easily filled with the porous granules, and also the nicotine inhalation path can be easily formed inside the outer tube.

[0022] As the porous granules, granules of silica gel are preferably used. Silica gel granules can absorb a large quantity of nicotine solution, thus prolonging the service life of the inhalation pipe.

[0023] Also, the outer tube may be made of transparent synthetic resin or semitransparently colored synthetic resin. In this case, the consumer can visually confirm through the outer tube that the color of the silica gel granules becomes pale as the vaporization of nicotine from the nicotine solution progresses, thus permitting the consumer to easily check the remaining amount of the nicotine solution, that is, the limit of use of the inhalation pipe.

[0024] The above object can also be achieved by a nicotine holder of the present invention which is applied to the nicotine inhalation pipe. The nicotine holder is constituted by the outer tube and the nicotine generator, both mentioned above.

[0025] Before use of the nicotine inhalation pipe or the nicotine holder, the outer tube is sealed at both ends or is wrapped in its entirety in a film, in order to prevent natural vaporization of nicotine.

BRIEF DESCRIPTION OF THE DRAWINGS

[0026] FIG. 1 is a longitudinal sectional view of a nicotine inhalation pipe according to a first embodiment;

[0027] FIG. 2 is a sectional view of the inhalation pipe of FIG. 1, with a nicotine holder and a mouthpiece detached from each other;

[0028] FIG. 3 is a longitudinal sectional view of a nicotine inhalation pipe according to a second embodiment;

[0029] FIG. 4 is a cross-sectional view taken along line IV-IV in FIG. 3;

[0030] FIG. 5 is a cross-sectional view taken along line V-V in FIG. 3;

[0031] FIG. 6 is a longitudinal sectional view of a nicotine inhalation pipe according to a third embodiment; and

[0032] FIG. 7 illustrates a nicotine inhalation pipe according to a fourth embodiment.

BEST MODE OF CARRYING OUT THE INVENTION

[0033] Referring to FIGS. 1 and 2, there is shown a nicotine inhalation pipe according to a first embodiment which comprises a rodlike nicotine holder 1 and a mouthpiece 2 attachable to the nicotine holder 1. The mouthpiece 2 has a connection end for the nicotine holder 1, and the connection end has a cylindrical shape with an outside diameter substantially equal to that of the nicotine holder 1. Thus, when the inhalation pipe is assembled, the mouthpiece 2 and the nicotine holder 1 form a smooth continuous outer peripheral surface of the inhalation pipe.

[0034] The nicotine holder 1 includes a transparent outer tube 3 and an inner tube 5 arranged inside the outer tube 3 coaxially therewith. The tubes 3 and 5 are both made of synthetic resin. A liquid absorbent 4 is filled in the space between the outer tube 3 and the inner tube 5 and is soaked with a nicotine solution.

[0035] As the nicotine solution, a solution prepared by dissolving chemically synthesized nicotine in a solvent such as aqueous liquid or alcohol or a solution prepared by dissolving nicotine extracted from tobacco leaves in a solvent may be used. To obtain the original aroma and flavor of tobacco, the tobacco extract solution is preferred. Also, such extract solution is advantageous in that it is not subject to any special legal controls, unlike medicines which need to be prescribed under the supervision of a doctor and a pharmacist.

[0036] Specifically, the extract solution signifies a solution prepared by soaking powder of tobacco leaves in a solvent and then obtaining a filtrate by filtering out the powder from the solvent, a solution prepared by thickening and then resolving the filtrate a solvent, or a solution prepared by subjecting tobacco leaves to dry distillation to extract a tar-like substance and then dissolving the tar-like substance in a solvent.

[0037] The extract solution has a low concentration of nicotine, and therefore, to obtain a nicotine solution having a nicotine content equivalent to that contained in one cigarette, presumably 500 to 1500 mg of the extract solution is required. Moreover, the nicotine holder 1 should desirably have a size approximately equal to that of an ordinary cigarette.

[0038] Accordingly, the liquid absorbent 4 is required to have an excellent absorption capacity for the extract solution and also to have the property of allowing the extract solution to be easily vaporized. A suitable material meeting these requirements is therefore selected as the liquid absorbent 4. Specifically, the liquid absorbent 4 is a granular material obtained by finely cutting, for example, nonwoven fabric, filter for cigarettes, absorbent cotton, etc. Such granular

material can be easily filled in the space between the outer tube 3 and the inner tube 5 and makes it possible to easily obtain the liquid absorbent 4.

[0039] The outer tube 3 has an inside diameter of 6 mm to 7 mm and a length of 50 mm to 70 mm, and the inner tube 5 has an outside diameter of 2 mm to 3 mm and a length of 45 mm to 65 mm. Accordingly, the nicotine holder 1 has a capacity of about 1.00 cc to about 2.50 cc for containing the liquid absorbent 4.

[0040] The nicotine solution, that is, the extract solution may be admixed with various additives, taking consumers' likings into consideration. As such additives, tobacco, mint, coffee, orange, tea, wine, etc. may be used. Also, the nicotine holder 1, that is, the outer tube 3 may be colored blue, brown, orange, green, wine-red or the like so as to indicate the kind of the additive used. Coloring the nicotine holder 1 in this manner not only permits a consumer to identify the taste that the nicotine holder 1 provides from its color but also visually pleases the consumer as well as people around him/her.

[0041] As shown in FIG. 1, the inner tube 5 has a large number of small holes 7 formed therein, and the small holes 7 are distributed over an entire area of the inner tube 5. The small holes 7 permit the liquid absorbent 4 to be partly exposed to the interior of the inner tube 5, that is, an internal flow passage 6. Accordingly, nicotine can vaporize through the small holes 7 from the nicotine solution absorbed in the liquid absorbent 4 and the vaporized nicotine flows into the internal flow passage 6.

[0042] To prevent the nicotine solution from vaporizing to an undesired extent, the opposite annular end faces of the liquid absorbent 4 and the opposite ends of the inner tube 5 are covered with film-like seals 8, respectively, as shown in FIG. 2. Specifically, each seal 8 is made of aluminum foil which can be torn with ease.

[0043] A plug (not shown) may be used in place of the seal 8. The plug is detachably fitted into each end of the inner tube 5 and has a flange covering the corresponding annular end face of the liquid absorbent 4.

[0044] As is clear from FIGS. 1 and 2, the opposite ends of the outer tube 3 project from the respective ends of the inner tube 5, that is, the liquid absorbent 4, thus forming recesses 30 at opposite ends of the nicotine holder 1.

[0045] Alternatively, the outer tube 3 and the inner tube 5 may have the same length. In this case, the opposite ends of the liquid absorbent 4 are positioned flush with the corresponding ends of the outer and inner tubes 3 and 5, and the seals 8 cover the respective annular end faces of the liquid absorbent 4 as well as the respective open ends of the inner tube 5 so as to wrap the corresponding end portions of the outer tube 3.

[0046] The outer tube 3 has an external thread 9 cut in the outer peripheral surface of each of the opposite end portions thereof. The external thread 9 is used to attach the aforementioned mouthpiece 2 to the nicotine holder 1.

[0047] More specifically, the mouthpiece 2 has a body 32 made of synthetic resin. The body 32 has a flattened tip 11 at one end and a cylindrical portion at the other end. The mouthpiece 2 may alternatively have a mere cylindrical overall shape.

[0048] The cylindrical portion has an inside diameter slightly larger than the outside diameter of the nicotine holder 1 and can slidably receive an end portion of the nicotine holder 1 therein. An internal thread 15 is cut in part of the inner peripheral surface of the cylindrical portion at a predetermined distance from the other end of the body 32.

[0049] Accordingly, an end portion of the nicotine holder 1 can be inserted into the cylindrical portion of the body 32 by the predetermined distance. Then, the nicotine holder 1 is rotated about its axis relative to the body 32, whereby the external thread 9 of the outer tube 3 becomes engaged with the internal thread 15 and thus the mouthpiece 2 is attached to the nicotine holder 1. Namely, the other end of the cylindrical portion constitutes the aforementioned connection end and also serves as a guide for guiding the insertion of the end portion of the nicotine holder 1.

[0050] A circular partition wall 13 is fixed inside the cylindrical portion approximately in the middle thereof and is located closer to the tip 11 than the internal thread 15. A filter 12 made of fibrous material is contained in the body 32 at a location between the partition wall 13 and the tip 11. The partition wall 13 serves as a stopper for preventing the filter 12 from coming off the mouthpiece 2. For the filter 12, a filter for cigarettes may be used.

[0051] Further, a through hole 17 is formed in the center of the partition wall 13 in communication with a hollow push-in pin 16. The push-in pin 16 is formed as an integral part of the partition wall 13 and extends toward the other end of the body 32 along the axis of same. The push-in pin 16 has an inside diameter slightly smaller than the inside diameter of the inner tube 5 of the nicotine holder 1 and can be inserted into the inner tube 5.

[0052] Where the nicotine holder 1 and the mouthpiece 2 are put to use, the nicotine holder 1, that is, the seals 8 are unsealed before the mouthpiece 2 is attached to the nicotine holder 1.

[0053] More specifically, one end of the nicotine holder 1 is inserted into the mouthpiece 2. As the nicotine holder 1 is inserted, the push-in pin 16 of the mouthpiece 2 fits into the one end of the inner tube 5 while breaking the seal 8 open. As a result, an intake opening 10 is formed at the one end (right-hand end) of the inner tube 5, as shown in FIG. 1.

[0054] Subsequently, the mouthpiece 2 is pulled off from the one end of the nicotine holder 1, and the other end of the nicotine holder 1 is inserted into the mouthpiece 2, whereby the seal 8 at the other end of the inner tube 5 is similarly broken open by the push-in pin 16. At this point, the nicotine holder 1 is open at both ends.

[0055] Then, the nicotine holder 1 is rotated about its axis relative to the mouthpiece 2. Consequently, the outer tube 3 and the mouthpiece 2 are connected together through the engagement between the external thread 9 and the internal thread 15, as mentioned above, thus obtaining the nicotine inhalation pipe shown in FIG. 1.

[0056] The mouthpiece 2 can be used to unseal the seals 8, as stated above, and therefore, no separate unsealing member is required.

[0057] Also, as is clear from FIG. 1, when the nicotine inhalation pipe is assembled by attaching the mouthpiece 2 to the nicotine holder 1, the hollow push-in pin 16 of the

mouthpiece 2 remains inserted into the inner tube 5, whereby a nicotine inhalation path extending from the one end of the nicotine holder 1 to the internal space of the tip 11 of the mouthpiece 2 is formed inside the nicotine inhalation pipe through the push-in pin 16. Namely, the nicotine inhalation path is constituted by the intake opening 10, the internal flow passage of the inner tube 5, the internal flow passage of the push-in pin 16, the through hole 17, and the filter 12.

[0058] When the consumer inhales through the inhalation pipe, a negative pressure is created within the nicotine holder 1, that is, the inner tube 5. Consequently, the outside air is introduced from the one end of the nicotine holder 1 into the inner tube 5, thus promoting vaporization of nicotine from the nicotine solution in the liquid absorbent 4 into the interior of the inner tube 5.

[0059] The vaporized nicotine is mixed with the air introduced into the inner tube 5 and then is sucked, together with the introduced air, into the consumer's mouth through the nicotine inhalation path.

[0060] Only the filter 12 exists in the nicotine inhalation path of the inhalation pipe, and therefore, the inhalation pipe has very small inhalation resistance.

[0061] Also, even if the nicotine solution leaks out into the inner tube 5, the nicotine solution is absorbed by the filter 12 in the mouthpiece 2 and does not flow into the consumer's mouth.

[0062] The outer and inner tubes 3 and 5 of the nicotine holder 1 and the body 32 of the mouthpiece 2 are all made of synthetic resin. As the synthetic resin, a biodegradable resin such as polylactic resin is preferably used.

[0063] FIG. 3 shows a nicotine holder 1 according to a second embodiment of the present invention, and this nicotine holder does not have the inner tube 5 and includes a cylindrical liquid absorbent 4. The liquid absorbent 4 has an outside diameter nearly equal to the inside diameter of the outer tube 3. A plurality of axial passages 18 are formed in the liquid absorbent 4 so as to extend therethrough. As shown in FIG. 4, a plurality of ribs 19 are formed on the inner peripheral surface of the outer tube 3. The ribs 19 are arranged at regular intervals in the circumferential direction of the outer tube 3 and extend in the axial direction of the outer tube 3. When the liquid absorbent 4 is press-fitted into the outer tube 3, the outer peripheral surface of the liquid absorbent 4 is partly deformed by the ribs 19. Accordingly, a gap is defined between the outer tube 3 and the liquid absorbent 4 on both sides of each rib 19, as viewed in the circumferential direction of the outer tube 3. These gaps respectively form outer axial passages 20 extending along the outer periphery of the liquid absorbent 4.

[0064] A mouthpiece 2 shown in FIG. 3 does not include the hollow push-in pin 16, and the partition wall 13 has a through hole 17 with a diameter larger than that of the through hole 17 shown in FIGS. 1 and 2. Also, the mouthpiece 2 is not a screw type but a plug type and thus is detachably fitted on one end of the nicotine holder 1.

[0065] Further, the nicotine holder 1, that is, the outer tube 3 has an end wall 22 at the other end thereof, and an inlet 21 is formed in the center of the end wall 22. The end wall 22

serves to increase the area of adhesion with the seal 8, thus improving the sealability of the end wall side of the nicotine holder.

[0066] As shown in FIG. 5, the other end portion of the outer tube 3 has a plurality of projections, that is, spacers 23 formed on the inner peripheral surface thereof. The spacers 23 are arranged at regular intervals in the circumferential direction of the outer tube 3 and serve to prevent the liquid absorbent 4 from moving toward the end wall 22. Accordingly, a chamber 24 with a given capacity is defined between the end wall 22 and the liquid absorbent 4 without fail.

[0067] The inhalation pipe shown in FIG. 3 is assembled by first removing the seals 8 from the opposite ends of the nicotine holder 1 and then attaching the mouthpiece 2 to the one end of the nicotine holder 1.

[0068] When air is inhaled through the inhalation pipe of FIG. 3, a negative pressure is created in the axial passages 18 within the liquid absorbent 4 as well as in the outer axial passages 20 of the absorbent 4, thus promoting vaporization of nicotine from the nicotine solution in the liquid absorbent 4 into the axial passages 18 and 20.

[0069] Also, because of the negative pressure created in the axial passages 18 and 20, the outside air is introduced from the inlet 21 into the chamber 24 and flows through the axial passages 18 and 20, the recess 30 located at the one end of the outer tube 3, and the mouthpiece 2, that is, the filter 12 in the mouthpiece. Consequently, the vaporized nicotine is sucked into the consumer's mouth together with the introduced air.

[0070] FIG. 6 shows a nicotine holder 1 according to a third embodiment of the present invention, and this nicotine holder contains a large number of liquid absorbent granules 34 in place of the liquid absorbent 4. The liquid absorbent granules 34 are filled in a transparent outer tube 3. The gaps between the liquid absorbent granules 34 and the gaps between the inner peripheral surface of the outer tube 3 and the liquid absorbent granules 34 form nicotine inhalation paths 27 and 28 inside the outer tube 3.

[0071] The outer tube 3 has end walls 22 at both ends, and a plurality of openings 36 are formed in each end wall 22. The openings 36 have a diameter significantly smaller than that of the liquid absorbent granules 34, and accordingly, the liquid absorbent granules 34 do not pass through the openings 36 to the outside of the outer tube 3.

[0072] The liquid absorbent granules 34 are porous spherical granules each having a large number of fine pores filled with the nicotine solution. The diameter of the liquid absorbent granules 34 is not particularly limited and may preferably be 0.5 to 2 mm, for example. Also, the liquid absorbent granules 34 may comprise either granules having an identical diameter or a mixture of granules with different diameters.

[0073] Specifically, the liquid absorbent granules 34 are made of silica gel (e.g., CARiACT® manufactured and sold by Fuji Silysia Chemical Ltd.), activated carbon, zeolite, porous ceramic containing silica gel as a main component, or a porous high polymer. In order for the liquid absorbent granules 34 to have fine pores of desired size, however, silica gel is preferably used to form the liquid absorbent granules 34. In this case, if the liquid absorbent granules 34 have fine

pores with an average diameter of 0.1 μm or more, in other words, if the total opening area of fine pores per 1 g of the liquid absorbent granules **34** is approximately 30 m^2 or more, the liquid absorbent granules **34** can retain a sufficient quantity of the nicotine solution. Moreover, sufficient nicotine can be vaporized from the nicotine solution (extract solution).

[0074] Further, the nicotine solution absorbed in the liquid absorbent granules **34** is preferably colored using a colorant. As the colorant, a food additive which is vaporizable like nicotine is used.

[0075] The nicotine holder **1** shown in **FIG. 6** also has the seals **8** covering the openings **36** at both ends thereof. The seals **8** are removed before the nicotine holder **1** is put to use. The mouthpiece **2** is then attached to one end of the nicotine holder **1**, whereby the inhalation pipe is assembled.

[0076] When air is inhaled through the inhalation pipe, a negative pressure is created in the nicotine inhalation paths **27** and **28** in the outer tube **3**, promoting vaporization of nicotine from the nicotine solution in the liquid absorbent granules **34** into the nicotine inhalation paths **27** and **28**. The vaporized nicotine flows through the nicotine inhalation paths **27** and **28**, together with the air introduced from the openings **36** at the other end of the outer tube **3**, and is sucked into the consumer's mouth through the filter **12** in the mouthpiece **2**.

[0077] As the inhalation pipe is repeatedly puffed and thus the nicotine in the nicotine solution is consumed, the liquid absorbent granules **34** gradually become white. The outer tube **3** is transparent or is semitransparently colored; therefore, the consumer can visually check the change in color of the liquid absorbent granules **34** through the outer tube **3**, permitting him/her to confirm with ease the remaining amount of the nicotine in the nicotine solution, that is, the consumption limit of the nicotine holder **1**.

[0078] Specifically, after the inhalation pipe is puffed 30 to 50 times, the liquid absorbent granules **34** in the outer tube **3**, that is, the colored granules of silica gel begin to turn pale from those granules located at the other end of the outer tube **3**, that is, the air inlet side of the nicotine holder, and the color of the granules finally changes to white, which is the original color of silica gel. Namely, those liquid absorbent granules **34** located at the air inlet side are exposed to fresh air at all times, and therefore, vaporization of nicotine from the nicotine solution progresses faster at the air inlet side than at the mouthpiece side of the inhalation pipe. Consequently, the liquid absorbent granules **34**, that is, the outer tube **3** whitens gradually from the air inlet side toward the mouthpiece **2**.

[0079] **FIG. 7** shows a nicotine holder **1** according to a fourth embodiment of the present invention, and this nicotine holder is provided with a heating sheet **38**. The heating sheet **38** is wrapped around the outer peripheral surface of the outer tube **3** except the end portion which is to be inserted into the mouthpiece **2**. The heating sheet **38** generates heat by the action of oxidation, for example, and before the nicotine holder **1** is put to use, the outer surface of the heating sheet **38** is covered with an outside air shutoff film **40**.

[0080] With this nicotine holder **1**, as the air shutoff film **40** is peeled from the heating sheet **38**, the heating sheet **38**

generates heat and the generated heat promotes the vaporization of nicotine inside the outer tube **3**, making it possible to increase the amount of nicotine taken in by the consumer per unit time.

[0081] When the aforementioned nicotine holders **1** shown in **FIGS. 1 through 7** are put to use, the nicotine holder is combined with the mouthpiece **2** to constitute the nicotine inhalation pipe. The nicotine holder **1** and the mouthpiece **2** may, however, be combined together in advance as a one-piece inhalation pipe. In this case, to prevent vaporization of nicotine from the nicotine holder **1**, the tip opening of the mouthpiece **2** and the outer end of the nicotine holder **1** are respectively covered with seals **8**, as indicated by the two-dot chain lines in **FIG. 3**.

[0082] The inhalation pipe or the nicotine holder may in its entirety be wrapped in film, and in this case the seals **8** are unnecessary.

1. A nicotine inhalation pipe comprising:

a rodlike outer tube opening at both ends;

a nicotine generator arranged inside the outer tube, said nicotine generator including a liquid absorbent in which a nicotine solution is absorbed and which permits nicotine to be vaporized from the nicotine solution, and a nicotine inhalation path extending substantially through said nicotine generator in an axial direction of said outer tube and distinctly separated from the liquid absorbent; and

a mouthpiece attached to one end of said outer tube.

2. The nicotine inhalation pipe according to claim 1, wherein said nicotine generator further includes:

an inner tube arranged inside said outer tube coaxially therewith such that said liquid absorbent is held between said inner and outer tubes, said inner tube having an interior forming the nicotine inhalation path; and

a large number of small holes formed in said inner tube and allowing nicotine to vaporize from the nicotine solution of said liquid absorbent into the interior of said inner tube.

3. The nicotine inhalation pipe according to claim 1, wherein said liquid absorbent has a cylindrical form extending through said outer tube, and

the nicotine inhalation path includes a plurality of axial passages extending through said liquid absorbent in the axial direction of said outer tube.

4. The nicotine inhalation pipe according to claim 3, wherein said nicotine generator further includes an outer axial passage defined between an outer peripheral surface of said liquid absorbent and an inner peripheral surface of said outer tube.

5. The nicotine inhalation pipe according to claim 1, wherein said outer tube has end walls at the respective opposite ends thereof, each of the end walls having an opening,

said liquid absorbent comprises porous granules filled in said outer tube and having a diameter larger than that of the openings, and

the nicotine inhalation path is formed by gaps between the granules and gaps between an inner peripheral surface of said outer tube and said granules.

6. The nicotine inhalation pipe according to claim 5, wherein said granules are made of silica gel.

7. The nicotine inhalation pipe according to claim 6, wherein said outer tube is made of transparent synthetic resin or semitransparently colored synthetic resin.

8. A nicotine holder comprising:

a rodlike outer tube opening at both ends; and

a nicotine generator arranged inside said outer tube, said nicotine generator including a liquid absorbent in which a nicotine solution is absorbed and which permits nicotine to be vaporized from the nicotine solution, and a nicotine inhalation path extending substantially through said nicotine generator in an axial direction of said outer tube and distinctly separated from said liquid absorbent.

9. The nicotine holder according to claim 8, wherein said outer tube has end walls at the respective opposite ends thereof, each of the end walls having an opening,

said liquid absorbent comprises porous granules filled in said outer tube and having a diameter larger than that of the openings, and

the nicotine inhalation path is formed by gaps between said granules and gaps between an inner peripheral surface of said outer tube and said granules.

10. The nicotine holder according to claim 9, wherein said granules are made of silica gel.

11. The nicotine holder according to claim 10, wherein said outer tube is made of transparent synthetic resin or semitransparently colored synthetic resin.

* * * * *