

(19) World Intellectual Property Organization  
International Bureau



(43) International Publication Date  
30 November 2000 (30.11.2000)

PCT

(10) International Publication Number  
WO 00/72491 A2

- (51) International Patent Classification<sup>7</sup>: H04J 14/02
- (21) International Application Number: PCT/US00/14567
- (22) International Filing Date: 25 May 2000 (25.05.2000)
- (25) Filing Language: English
- (26) Publication Language: English
- (30) Priority Data:  
60/135,909 25 May 1999 (25.05.1999) US
- (71) Applicant: CIRREX CORP. [US/US]; Suite N-205, 430 Tenth Street, N.W., Atlanta, GA 30318 (US).
- (72) Inventors: MEDIN, Michael, W.; 8585 Steeplechase Drive, Roswell, GA 30076 (US). WACH, Michael, L.; 914 Collier Road, N.W. #6005, Atlanta, GA 30318 (US).
- (74) Agent: WIGMORE, Steven, P.; King & Spalding, 191 Peachtree Street, Atlanta, GA 30303-1763 (US).
- (81) Designated States (*national*): AE, AG, AL, AM, AT, AU, AZ, BA, BB, BG, BR, BY, CA, CH, CN, CR, CU, CZ, DE, DK, DM, DZ, EE, ES, FI, GB, GD, GE, GH, GM, HR, HU, ID, IL, IN, IS, JP, KE, KG, KP, KR, KZ, LC, LK, LR, LS, LT, LU, LV, MA, MD, MG, MK, MN, MW, MX, MZ, NO, NZ, PL, PT, RO, RU, SD, SE, SG, SI, SK, SL, TJ, TM, TR, TT, UA, UG, UZ, VN, YU, ZA, ZW.
- (84) Designated States (*regional*): ARIPO patent (GH, GM, KE, LS, MW, MZ, SD, SL, SZ, TZ, UG, ZW), Eurasian patent (AM, AZ, BY, KG, KZ, MD, RU, TJ, TM), European patent (AT, BE, CH, CY, DE, DK, ES, FI, FR, GB, GR, IE, IT, LU, MC, NL, PT, SE), OAPI patent (BF, BJ, CF, CG, CI, CM, GA, GN, GW, ML, MR, NE, SN, TD, TG).

**Published:**  
— Without international search report and to be republished upon receipt of that report.

For two-letter codes and other abbreviations, refer to the "Guidance Notes on Codes and Abbreviations" appearing at the beginning of each regular issue of the PCT Gazette.

(54) Title: METHOD AND SYSTEM FOR INCREASING A NUMBER OF INFORMATION CHANNELS CARRIED BY OPTICAL WAVEGUIDES

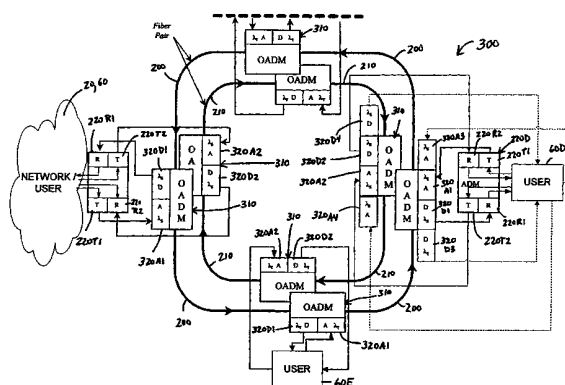

(57) Abstract: An optical add/drop multiplexing (OADM) device can increase the number of information channels carried by an optical waveguide by utilizing different wavelength regions of light. In other words, each information channel can be assigned a specific wavelength region of light. The OADM device can add additional virtual optical waveguides equal to the number of wavelength regions of light that can be efficiently propagated along a single optical waveguide. The OADM device can utilize conventional diode laser technology for adding information channels at predefined wavelength regions into an optical network. The OADM device can stabilize the output wavelength region of a conventional laser diode to any specific wavelength region with minimal hardware or structural modifications. By utilizing off the shelf hardware, the OADM device can lower manufacturing costs while providing an ample supply of spare parts. Further, the OADM device can be used to amplify optical signals that propagate along the improved optical networks of the present invention. The OADM device can be easily interfaced with terminals designed for Synchronous Optical NETWORKS (SONETs). Also, the OADM device permits functionality of a conventional optical network to remain the same or constant. The OADM device employs cascading and planar light guide circuits to minimize hardware and to reduce signal losses.

WO 00/72491 A2



METHOD AND SYSTEM FOR INCREASING A NUMBER OF INFORMATION  
CHANNELS CARRIED BY OPTICAL WAVEGUIDES

STATEMENT REGARDING RELATED APPLICATIONS

5           This application is related to U.S. Application Serial Number,  
\_\_\_\_\_, entitled, "Optical Feedback Assembly," filed May 25, 2000, and  
claims benefit of priority to U.S. Provisional Application Number, 60/135,909,  
entitled, "System For Wavelength Division Multiplexing In Fiber Optic Access  
Networks," filed May 25, 1999.

10

TECHNICAL FIELD

          This invention relates generally to optical networks. More particularly, the  
present invention relates to increasing a number of information channels carried by  
optical waveguides within an optical network.

15

BACKGROUND OF THE INVENTION

          In recent years, the use of optical fibers has become increasingly widespread  
in a variety of applications. Optical fibers have been found to be especially useful for  
many industries such as telecommunications, computer-based communications, and  
20 other like applications.

          For example, in the conventional art as illustrated in Fig. 1, a long-haul  
network 10 connects central offices or points of presence (PoPs) 20 of one city to  
another. The long-haul network 10 typically utilizes optical waveguides, such as fiber  
optic cables, that carry information propagating in the 1550 nanometer wavelength  
25 region. The long-haul network 10 can interconnect major population areas together.  
For example, if the central office 20 that connects to the long-haul network 10 was  
part of a regional hub such as Atlanta, then the central office 20 would have long-haul  
fiber optic cable routes to Dallas, Chicago, New York, and other major population  
areas. The long-haul network 10 can be maintained by interexchange carriers (IXCs),  
30 such as AT&T, MCI, Sprint, and other like new companies that handle long distance  
communications.

Each central office or point of presence (PoP) 20 is interconnected to an adjacent central office 20 by optical waveguides 30 that form an interoffice network 40. An interoffice network 40 can be maintained by a local exchange carrier (LEC) such as Bell South, Bell Atlantic, and other companies that handle local communications. Each central office 20 of the interoffice network 40 can also be  
5 connected to optical waveguides 50 that form an access network or ring 70. Within an access network or ring 70, each central office 20 can be connected to one or more users 60. A user 60 can comprise local area networks (LANs) that provide services to individual personal computers or voice communications. Each access network 70  
10 may extend across a geographic region on the order of 10 miles (more or less) in circumference, while the interoffice networks 40 may span a geographic region that is in the order of 50 to 100 miles (more or less) in circumference.

Because of the relative size of the access networks 70, communication providers typically employ synchronous optical network (SONET) standards for  
15 multiplexing and transporting data streams through the optical waveguides 50. The SONET standard is based upon a time division multiplexing (TDM) technique. However, despite the use of the time division multiplexing technique, conventional access networks 70 are approaching bandwidth exhaustion due to the demand created by the public Internet and/or virtual private intranets. Conventional access networks  
20 70 are typically designed as optical carrier 3 (OC3) SONET rings meaning that the maximum capacity at any point in the optical waveguides 50 that form the access networks 70 have a capacity of 155 megabits per second. OC3 SONET rings can carry only three DS3 signals or eighty four DS1 signals on a entire ring. DS stands for a classification of transmitting one or more communications in a digital data  
25 stream. A DS1 level means that data is transmitted at 1.544 megabits per second while DS3 signals transmit data at 45 megabits per second. Users 60 are pressuring access network providers to support data transmitted at DS3 or higher rates as opposed to DS1 rates because current LANs operate much faster than DS1 streams.

To increase capacity of conventional optical networks, such as to  
30 accommodate eighty five DS1 signals or a fourth DS3 service, an entire OC3 SONET ring or access network 70 would require an upgrade to the optical carrier 12 (OC12) level that permits a maximum transmission capacity of 622 megabits per second at

any point in an optical fiber. Such an upgrade would require complete replacement of add/drop multiplexers (ADMs) **220** (See Fig. 2) in the ring with larger capacity units.

Adding to the complexity of an upgrade to the SONET ring **70A** is the current reliance by the industry on the unidirectional path switched ring (UPSR), as illustrated in Fig. 2. The UPSR **70A** is a SONET architecture that is particularly well-suited for access networks **70** in which traffic from multiple users **60** is hubbed into a network provider's central office or a point of presence (PoP) **20**. The UPSR **70A** includes fiber pairs **200, 210** that link multiple SONET add/drop multiplexers (ADMs) **220B-220E** located at central offices/PoPs **20** and at remote locations accessible to users **60**. Traffic, in the form of DS1 or DS3 serial data bit streams originating from each user **60**, is multiplexed into the UPSR aggregate bit stream along optical waveguides **200, 210** at OC-3 or OC-12 data rates for transport to the central office or point of presence (PoP) **20**. For example, a user **60D** typically "adds" an information signal to the aggregate data bit stream propagating along the outside optical waveguide **200** via the transmitter **220T1**. Similarly, the user **60D** "drops" an information signal from the aggregate data bit stream propagating along the outside optical waveguides **200** via the receiver **220R1**.

Information traffic normally flows in one direction around the SONET ring **70A**, using the working fiber **200** as indicated by the arrows denoting counter-clockwise flow. In the event of a single fiber or ADM transceiver failure, the information traffic is automatically redirected around the SONET ring **70A**, using a protection fiber **210** in accordance with the UPSR automatic protection switching (APS) feature. For example, if two optical waveguides between two ADMs **220** simultaneously fail at points **240**, such as optical waveguides **200** and **210** between user **60D** and user **60E**, then the UPSR APS feature will cross-connect the remaining working and protection fibers **200, 210** to bypass the failed sections in order to maintain continuity of information flow at each user's connection. Therefore, instead of user **60D** "adding" and "dropping" information signals from the working optical waveguide **200**, the user **60D** would "add" signals to the working optical waveguide **200** via transmitter **220T1** and "drop" information signals from the protection optical waveguide **210** via the backup receiver **220R2** as illustrated in Fig. 2.

The robust protection switching capabilities of the UPSR make this SONET architecture preferable to other conventional topologies, such as star and tree-branch topologies for high availability fiberoptic access networks. With this protection scheme, a central office or point of presence (PoP) 20 would "receive" or "drop" information signals with the primary receiver 220R1 and transmit or "add" information signals to the SONET network 70A via the backup or secondary transmitter 220T2. It is noted that the "working" fiber 200 and "protection" fiber 210 may not be dedicated lines. In other words, the APS feature of an USPR may comprise complex switching techniques where a "working" or "protection" fiber is merely an optical path within an optical fiber that is a result of the complex switching techniques. The working fibers 200 and protection fibers 210 have been denoted as such in Fig. 2 for illustrative purposes only. That is, protection fibers 210 of Fig. 2 may carry information continuously while only an optical path generated by a switching technique is dedicated within the protection fiber 210 for the APS feature.

While the automatic protection switching feature of a unidirectional path switched ring makes a SONET architecture very desirable and dependable, such an optical architecture still suffers from signal losses that are present in any optical architecture. In order to compensate for such signal losses, amplifiers may be needed within each respective optical network 70A. However, conventional optical amplifiers, such as Erbium Doped Fiber Amplifiers (EDFAs), only operate in the 1530-1560 nanometer wavelength range. That is, conventional optical amplifiers are not designed to function within the 1310 nanometer wavelength range of interoffice networks 40 and access networks 70.

Accordingly, a need in the art exists for a method and system that can amplify optical signals propagating at various wavelength regions. More specifically, there is a need in the art for an optical amplifier that can be utilized in interoffice networks, access networks, and well as long haul networks. An additional need in the art exists for a method and system for increasing a number of information channels that can be carried by an optical waveguide. There is a further need in the art for a method and system for increasing a number of information channels carried by an optical waveguide that can be readily adapted or configured to work with existing optical network architectures. That is, there is a need in the art for a method and system that

can increase a number of information channels carried by an optical waveguide but where an existing SONET architectures or SONET protocol is not affected by the increase in information channels. Specifically, there is a need in the art for a method and system that can substantially increase information traffic carried by an optical waveguide but can still retain the benefits of an automatic protection switching feature of a unidirectional path switched ring. Another need exists in the art for a method and system that can increase information traffic carried by an optical waveguide at relatively low cost with out replacing existing optical equipment and in a way where spare parts can be easily manufactured.

10

### SUMMARY OF THE INVENTION

The present invention solves the problems of conventional optical networks by providing an optical add/drop multiplexing (OADM) device that can increase the number of information channels carried by an optical waveguide. The OADM device can increase the number of information channels within an optical waveguide by utilizing different wavelength regions of light. In other words, each information channel can be assigned a specific wavelength region of light. It is noted that a "wavelength region" can be defined as a span of wavelengths that is adjacent or approximate to a specific wavelength. In other words, a wavelength region of  $\lambda_1$  can include neighboring wavelengths of a desired threshold. For example, if it is desirable to have a threshold of one-fourth, a wavelength region of  $\lambda_1$  could encompass wavelengths that are 0.25 below and above the central wavelength of  $\lambda_1$ . The threshold can be adjusted depending upon the application of the present invention.

By carrying information on multiple wavelength regions of light, the present invention can add virtual optical waveguides to existing physical optical waveguides. Stated differently, the present invention can carry information along information channels equivalent to separate dedicated physical optical waveguides that could be added to existing optical network systems. The OADM device can add additional virtual optical waveguides equal to the number of wavelength regions of light that can be efficiently propagated along a single optical waveguide. This means that if an optical waveguide can propagate twelve different wavelength regions of light, then an

optical waveguide propagating light energy in this fashion would be equivalent to twelve separate conventional waveguides that could each carry a single wavelength region.

5 The present invention has an architecture such that it can be overlaid on conventional optical networks with minimal hardware or retrofitting or both. The invention can create additional optically transparent paths that permit the use of conventional optical network terminals. For example, the present invention can be easily interfaced with terminals designed for Synchronous Optical NETWORKS (SONETs). Further, the OADM device permits functionality of a conventional  
10 optical network to remain the same or constant.

In other words, if a conventional optical network, such as a SONET ring, has a protective switch capability where a protection optical waveguide is used if a working optical waveguide is broken or incapable of handling its information traffic, then such a protective switch capability would operate similarly as if the OADM device was not  
15 present. Stated simply, the present invention can be overlaid on conventional optical network systems such that an information channel operating according to a conventional network protocol is unaffected. Meanwhile, the present invention provides additional channels that do not need to be dependent on the conventional optical network protocol.

20 In addition to providing multiple channels that can be independent of a conventional network protocol, the present invention can utilize conventional protection optical waveguides for regular information traffic to increase the number of optical paths that lead to a central office or optical network service provider. That is, by utilizing conventional protection optical waveguides that exist in conventional  
25 optical network structures, such as SONET rings, the number of paths that lead to a central office can be doubled. For example, if a user is assigned a non-SONET information channel of a particular wavelength region and if two conventional optical waveguides of a SONET UPSR are utilized for information traffic, then the assigned non-SONET information channel for the user can have two bi-directional information  
30 routes that lead back to a central office.

With the present invention, information channels that propagate at predefined wavelength regions and that are unassigned at a particular terminal can be passed

through a terminal with little or no energy loss. That is, the OADM device uses cascading technology that lets unwanted or unassigned information channels to pass through a terminal with minimal hardware. Conversely, conventional multiplexing technology typically requires a plurality of separate optical waveguides that are later recombined into a single optical device. Unlike the conventional multiplexing technology, the present invention has less hardware which, in turn, decreases the potential for any insertion losses.

The OADM device can utilize conventional diode laser technology for adding information channels at predefined wavelength regions into an optical network. In other words, the OADM device can stabilize the output wavelength region of a conventional laser diode to any specific wavelength region with minimal hardware or structural modifications. By utilizing off the shelf hardware, the OADM device can lower manufacturing costs while providing an ample supply of spare parts. Further, the same technology of the OADM device that increases the operating wavelength spectrum of conventional laser diodes can be used to amplify optical signals that propagate along the improved optical networks of the present invention. This dual functionality of the OADM device can further decrease its manufacturing costs.

The structure and functionality of the OADM device contribute to an efficient electronic packaging design. Each OADM device yields to an efficient field configurable unit that can be easily installed or replaced or both at a particular terminal. For example, each OADM device can be designed to add or drop (or add and drop) only one channel of a specific wavelength region. A terminal can include two OADM devices, one for each fiber of a two fiber network ring. Each OADM device may be configured with one or more wavelength adapter modules (discussed below) depending upon the number of information channels that will be handled by a particular terminal. That is, if a terminal is designed to operate on four wavelength regions, then four wavelength adapter modules can be installed within each OADM device for that terminal.

Each OADM device can comprise a wavelength adapter module and a filter module. Each wavelength adapter module can comprise a photodetector, a laser diode, and a Bragg grating. The Bragg grating can be combined with an optical waveguide. That is, the Bragg grating can be disposed within or adjacent to the



optical waveguide. Each wavelength adapter module can be connected to a respective filter module that includes a planar light guide circuit and one or more optical waveguides and thin film interference filters. Each wavelength adapter module can be designed to modulate an incoming optical signal at a predefined wavelength region.

In one exemplary embodiment, the OADM device can drop one or more specific information channels operating at predefined wavelength regions at a terminal. In such an embodiment, the output ports of a filter module can be connected to input ports of a telecommunication device or computing device.

In another exemplary embodiment, the OADM device can amplify one or more specific information channels operating at predefined wavelength regions. In this embodiment, the output ports of a filter module can be redirected to the input ports of respective wavelength adapter modules. The wavelength adapter modules can, in turn, amplify the optical energy present at their input ports.

15

#### BRIEF DESCRIPTION OF THE DRAWINGS

Fig. 1 is a diagram illustrating a conventional long-haul network that connects conventional central offices or points of presence of one city to another.

Fig. 2 is a diagram illustrating a conventional SONET access network.

Fig. 3 illustrates an exemplary optical network that includes a SONET network overlaid with optical add/drop multiplexing (OADM) devices of the present invention.

Fig. 4 is a diagram that illustrates an OADM device according to an exemplary embodiment of the present invention.

Fig. 5 is a diagram that illustrates an amplifying configuration of the OADM device according to an alternate exemplary embodiment of the present invention.

Fig. 6 is a diagram that illustrates a filter module of an OADM device according to an exemplary embodiment of the present invention.

Fig. 7 is a logic flow diagram illustrating a process for increasing a number of information channels carried by an optical waveguide in accordance with an exemplary embodiment of the present invention.

Fig. 8 is a logic flow diagram illustrating an exemplary routine corresponding to Fig. 7 for transforming unstabilized non-monochromatic or monochromatic light energy into stabilized monochromatic light energy in accordance with an exemplary embodiment of the present invention.

5 Fig. 9 is a logic flow diagram of an exemplary routine of Fig. 7 for separating light energy in to distinct information channels in accordance with an exemplary embodiment of the present invention

Fig. 10 is a logic flow diagram of an exemplary routine of Fig. 7 for amplifying light energy in accordance with an exemplary embodiment of the present  
10 invention

#### DETAILED DESCRIPTION OF EXEMPLARY EMBODIMENTS

With the present invention, additional virtual optical waveguides equal to the number of wavelength regions of light that can be efficiently propagated along a  
15 single waveguide can be added to existing optical network architectures. That is, the OADM device of the present invention can increase the number of information channels carried by an optical waveguide by utilizing different wavelength regions of light to propagate information signals. Each information channel generated by the present invention can be assigned a specific wavelength region of light so that  
20 multiple channels can be propagated simultaneously along a single optical waveguide. As noted above, a "wavelength region" can be defined as a span of wavelengths that are adjacent or approximate to a specific wavelength. In other words, a wavelength region of  $\lambda_1$  can include neighboring wavelengths of a desired threshold. For example, if it is desirable to have a threshold of one-fourth, a wavelength region of  $\lambda_1$   
25 could encompass wavelengths that are 0.25 below and above the central wavelength of  $\lambda_1$ . The threshold can be adjusted depending upon the application of the present invention.

The present invention can be overlaid on conventional optical networks with minimal hardware or retrofitting. The present invention can be overlaid on  
30 conventional optical network systems such that information channels operating according to conventional network protocols are unaffected. Meanwhile, the present

invention provides additional channels that do not need to be dependent on the conventional optical network protocols therein.

The present invention can utilize conventional laser diode technology for adding information channels at predefined wavelength regions into an optical network. The present invention can stabilize the output wavelength region of a conventional laser diode to any specific wavelength region with minimal hardware or structural modifications. By utilizing off the shelf hardware, the present invention can lower the manufacturing costs of an optical network while providing an ample supply of spare parts. Further, the present invention can be used to amplify optical signals in addition to increasing the operating wavelength spectrum of a conventional laser diode.

Referring now to the drawings, in which like numerals represent like elements throughout the several figures, aspects of the present invention in the preferred operating environment will be described.

Fig. 3 illustrates an exemplary optical network **300** that includes a SONET network overlaid with optical add/drop multiplexing (OADM) devices **310** of the present invention. Each OADM device **310** of user **60D** and network/user **20,60** is connected to a respective transmitter/receiver pair of an ADM terminal **220** in addition to a respective pair of fibers. For example, the add/drop multiplexer **220B** connected to the central office or point of presence (PoP) **20** has two sets or pairs of transmitters and receivers **220T1**, **220R1**, **220T2**, and **220R2**. A first or primary receiver **220R1** of the ADM **220B** is connected to a drop channel **320D1** of an OADM device **310**. Similarly, a first or primary transmitter **220T1** of the ADM **220B** is connected to an add channel **320A1** of the OADM **310**. The second or secondary transmitter **220T2** of ADM **220B** is connected to an add channel **320A2** of an OADM device **310** that is also connected to an optical waveguide **210** that forms an inner ring of the optical network **300**. The second or secondary receiver **220R2** of the ADM **220B** is connected to a drop channel **320D2** of the OADM device **310** that is connected to the optical waveguides **210** that form the inner ring of the network **300**. The remaining users, such as user **60C**, can have OADM devices **310** according the present invention connected to SONET terminals or the OADM devices **310** directly connected to the respective optical waveguides **200**, **210**. In another exemplary

embodiment, user **60D** can also be directly connected to OADM devices **310** via add channels **320A3**, **320A4** and drop channels **320D3**, **320D4** in addition to the channels connected to the OADM devices **310** via the ADM terminal **220D**. The user **60D** can send non-SONET information to the network **300** via add channels **320A3**, **320A4** and receive non-SONET information via drop channels **320D3**, **320D4**.

With the optical network **300** illustrated in Fig. 3, ADM terminals **220B** and **220D** can support conventional network protocols without any interference or interaction from the OADM devices **310** of the present invention. In other words, the present invention can be overlaid on conventional optical network systems such that an information channel operating according to a conventional network protocol is unaffected. This means that the automatic protection switching (APS) feature of unidirectional path switched rings for SONET networks can be utilized with the present invention. Such automatic protecting switching features operate seamlessly as if the OADM devices **310** were not present within the optical network **300**.

In addition to permitting conventional network protocols to be propagated therein, the present invention can create additional virtual optical waveguides equal to the number of wavelength regions of light that can be efficiently propagated along a single waveguide. Further, in addition to the extra information channels that are made available for each respective optical waveguide within the network **300**, the present invention can increase the number of optical paths that lead to a central office or point of presence (PoP) within an optical network **300**. That is, by utilizing all of the optical waveguides available to each OADM device **310** of the present invention, the number of paths that lead to a central office or point of presence (PoP) can be doubled. For example, a user **60E** that is connected directly to OADM devices **310**, without any interface with a SONET ADM terminal, can utilize both sets of add/drop channels **320A1**, **320A2**, **320D1**, and **320D2** to propagate information to the central office or point of presence (PoP) **20**. That is, the user **60E** can propagate non-SONET information channels along optical waveguides **200** of the outer ring in counter clockwise direction.

The user **60E** can propagate non-SONET information channels along the optical waveguides **210** of the inner ring in a clockwise direction. Similarly, the user **60D**, who is also connected directly to the OADM devices **310** via add channels

320A3, 320A4 and drop channels 320D3, 320D4, can propagate non-SONET information channels along optical waveguides 200 and 210. The term, "non-SONET information channel" is defined as an information channel which does not operate according to any SONET protocol. With the present invention, both SONET protocol and non-SONET information channels can be propagated simultaneously on the same access network, thus expanding the network's information carrying capacity. Typically, for propagating non-SONET information channels, a user will be directly connected to a respective set of OADM devices 310.

Further to increasing the number of information routes that lead back to a central office or point of presence (PoP) 20, the present invention permits information channels that propagate at predefined wavelength regions and that are unassigned at a particular terminal to be passed through such a terminal with little or no energy loss. That is, the OADM devices 310 that are disposed between the user 60D and central office or point of presence (PoP) 20 may use cascading technology to let unwanted or unassigned information channels to pass through a respective OADM device 310 with minimal hardware and signal losses. In other words, a single optical channel operating at a predefined wavelength region can be assigned to the user 60 and central office or point of presence (PoP) 20. In this way, the OADM devices 310 between the users 60D and each central office or point of presence (PoP) 20 can permit unwanted or unassigned information channels to pass through a respective terminal 220 with minimal hardware or signal losses or degradation.

For example, optical or light energy operating according to a SONET protocol and at a wavelength region of  $\lambda_s$  would be manipulated (dropped or added or both) by a respective OADM devices 310 operating at an assigned wavelength region of  $\lambda_s$ . Conversely, those OADM devices 310 that are assigned some arbitrary information channel operating according to a non-SONET protocol and at a wavelength  $\lambda_T$  would permit information operating according to a SONET protocol and at the wavelength region  $\lambda_s$  to pass therethrough without any further signal losses or manipulation of data content.

As noted above, if a user is assigned a non-SONET information channel of a particular wavelength region, such as  $\lambda_T$ , and if two conventional optical waveguides of the SONET ring 300 are utilized for regular information traffic, then the assigned

non-SONET wavelength region  $\lambda_T$  of light for a user can have two bi-directional information routes that lead back to the central office or point of presence (PoP) 20. More specifically, a user 60E can transmit non-SONET information with add channel 320A1 of the OADM device 310. The add channel 320A1 feeds optical energy into optical waveguide 200. Similarly, the user 60E can also transmit non-SONET information with add channel 320A2 that is connected to the secondary optical waveguide 210. The user 60E can receive information from drop channel 320D2 which is connected to secondary optical waveguide 210. The user 60E can also receive information via drop channel 320D1 that is connected to the primary optical waveguide 200.

In summary, each adjacent respective pair of add and drop channels, such as add channel combination 320A1 and 320A2, and drop channel combination 320D1 and 320D2 form bi-directional information routes that link a user 60E to a central office or point of presence (PoP) 20. These bi-directional information routes are available for the information channels that propagate at wavelength regions outside of the information channel that propagates according to SONET protocol and the automatic protection switching features. In other words, such bi-directional information routes are usually only available for non-SONET information channels.

Fig. 4 is a diagram that illustrates an OADM device 310 according to an exemplary embodiment of the present invention. Each OADM device 310 may include one or more wavelength adapter modules 400 that are connected to a filter module 410. The filter module 410 can incorporate a number of fiber optic light manipulation and management methods that are described in U.S. Patent No. 5,953,477 issued to Wach et al., and are marketed by the assignee of the present application, Cirrex, Inc. of Atlanta, Georgia. The content of U.S. Patent No. 5,953,477 is hereby incorporated by reference.

Each wavelength adapter module 400 includes a light detecting device 420, an optical feedback assembly 430, and a laser device 440. Each light detecting device 420 can comprise a photo detector. An optical feedback assembly 430 can comprise a filtering device in combination with a partial reflecting device or a wavelength selective reflector positioned proximate to the laser device 440 for propagating a predefined wavelength region back into the laser device 440. The signal of the optical

feedback assembly **430** fed back into the laser device **440** causes the laser device to become substantially stabilized within the wavelength region of the reflected optical energy. The laser device **440** can be a Fabry-Perot semiconductor laser. Other types of lasers are not beyond the scope of the present invention.

5           The laser device **440** may have an output which is modulated so as to produce a dense wavelength division multiplexing (DWDM) channel. It is noted that dense wavelength division multiplexing refers to a process where multiple channels of information are propagated at different wavelength regions that can be spaced spectrally at a set wavelength or frequency distance apart from one another. On the  
10 other hand, wavelength division multiplexing (WDM) may refer to a process where information channels are propagated at different wavelength regions that are hundreds of nanometers apart. For example, in WDM, an information channel may propagate at the 1310 wavelength region of the optical spectrum while another information channel may propagate at the 1550 nanometer wavelength region of the optical  
15 spectrum. For DWDM, information channels can propagate at industry standard spacings that may be on the order of one or two wavelengths (or a fraction thereof), such as one or two nanometers, apart from one another.

The optical feedback assembly **430** can be a Bragg grating that is a form of external feedback control which can maintain the laser output wavelength region to  
20 within one nanometer of the Bragg wavelength. In one exemplary embodiment, the optical waveguide for the Bragg grating supports single mode light propagation. Alternatively, optical feedback assembly **430** can employ thin-film interference filters in combination with a partial reflector or mirror within an optical waveguide stub (not shown) to achieve similar feedback control. Details of the optical feedback assembly  
25 have been developed and are marketed by the assignee of the present application, Cirrex, Inc. of Atlanta, Georgia. Additional details for the optical feedback assembly **430** are described in commonly assigned, U.S. Patent Application Serial No.

, filed May 25, 2000, entitled "Optical Feedback Assembly", the content of which is hereby incorporated by reference.

30           The optical feedback assembly **430** can be designed so that the laser device **440** "locks" on to a the predetermined wavelength region produced by the optical feedback assembly **430**. The predetermined wavelength region can support a single

information channel. Multiple predetermined wavelength regions can be generated by separate laser devices 440 such that multiple information channels can be generated. The multiple predetermined wavelength regions can form a spectral grid that includes the 1310 nm or 1550 nm wavelength regions. The 1310 nm wavelength region is typically the operating wavelength regions for access networks, while the 1550 nm wavelength region is typically the operating wavelength region for long-haul networks.

Unstabilized non-monochromatic or monochromatic light energy can be received at input port 460 which feeds into the filter module 410. The filter module 410 can drop one or more information channels propagating at predefined wavelength regions via drop ports 465, 470, and 475. The filter module 410 employs cascading technology that can permit unwanted or unassigned information channels to pass through the OADM device 310 with minimal hardware. In other words, unassigned information channels can flow through the filter module 410 of a respective OADM device 410 without significant manipulation. Alternatively, as illustrated in Fig. 4, the filter module 410 can be designed to drop channels propagating at predefined wavelength regions such as  $\lambda_1$ ,  $\lambda_2$ , and  $\lambda_N$ . Further details of the filter module will be described with respect to Fig. 5.

In addition to performing a dropping function, the filter module 410 can also add and recombine one or more channels of information via add ports 480, 485, and 490. Each add port 480, 485, and 490 can receive unstabilized non-monochromatic or monochromatic light energy. This light energy is then fed into a respective wavelength adapter module 400 which can transform unstabilized non-monochromatic or monochromatic light energy into one channel of stabilized monochromatic light energy having a predefined wavelength region.

For example, add port 480 could receive conventional unstabilized monochromatic light energy that is being propagated according to a SONET protocol. This light energy is then fed into the photo detector 420 of the wavelength adapter module 400. The photo detector 420 then modulates the output of the laser device 440. The optical feedback assembly 430 can then output stabilized monochromatic light energy having a predefined wavelength region, such as  $\lambda_1$ . This stabilized monochromatic light energy having the predefined wavelength region of  $\lambda_1$  can then



be fed into the filter module **410** where it is recombined with the light energy propagating through the filter module **410**.

After dropping, adding, and recombining one or more channels of stabilized monochromatic light energy, the filter module **410** then can output a wavelength division multiplexed light signal at Output port **495**. Since the wavelength adapter modules **400** are required only when a signal from external equipment is to be added to the wavelength-multiplexed optical signal or amplified (as discussed below), the OADM device **310** can be flexibly configured with one or more wavelength adapter modules **400**. The wavelength adapter modules **400** can installed in the field when a new information channel is desired or when existing information channels are reallocated or shifted from their existing operating wavelength regions. For each of the information channels in which a wavelength adapter module **400** is not installed, the drop port of the filter module can be looped back (not shown in Fig. 4 but shown in Fig. 5, discussed below) to a corresponding input port so that these information channels are passed through the filter module **410** without any significant signal loss and with minimal hardware.

Fig. 5 is a diagram that illustrates an amplifying configuration according to an alternate exemplary embodiment of the present invention. In Fig. 5, an OADM device **500** is configured to amplify stabilized monochromatic light energy that may have one or more information channels propagating at one or more predefined wavelength regions. In the exemplary embodiment illustrated in Fig. 5, the OADM device **500** is designed to amplify an information channel propagating at a predefined wavelength region of  $\lambda_2$ . When wavelength division multiplexed light energy enters into the Input port **460**, it is then fed into a filter module **410** where multiple information channels can be dropped and passed through the filter module **410**.

For the information channel propagating at the predefined wavelength region of  $\lambda_2$ , this information channel is dropped and then fed into add port **485**. The light energy is then manipulated by the wavelength adapter module **400B**. Because the light energy fed into the wavelength adapter module **400B** is remodulated, the light energy is also amplified. This amplified light energy or information channel propagating at the predefined wavelength region of  $\lambda_2$  is then fed back into the filter module **410** where it is recombined with the light energy propagating through the

filter module **410**. With the embodiment of the OADM device **500** illustrated in Fig. 5, light energy can be amplified so that it can propagate through large-circumference access rings.

Fig. 6 is a diagram that illustrates a filter module **410** according to an exemplary embodiment of the present invention. In this exemplary embodiment, light energy having information channels propagating at predefined wavelength regions of  $\lambda_1$  through  $\lambda_N$  can be introduced into a planar light guide circuit (PLC) **600** via an input waveguide **610I**. The PLC **600** can have multiple optical paths **620** for propagating light energy in a single mode format. More specifically, the optical paths **620** can be properly dimensioned to only support single mode propagation of light energy. While the optical paths **620** have been illustrated as arrows in the drawings, it is noted that these optical paths typically have a cylindrical cross section, where the optical paths **620** are surrounded by another material or materials that do not support light propagation. The PLC **600** can be designed to channel or propagate optical energy to filtering devices A-D so that the light energy is separated into a plurality of discrete information channels.

The filtering devices A-D can be attached directly to the PLC **600** or they can be attached to respective optical waveguides **610** that can be also connected to the PLC **600**. The zig zagging of optical paths **620** disposed within the PLC **600** and the flow direction of light energy passing through PLC **600** is often referred to as "cascading". The first reflection of stabilized monochromatic light energy at filter A in waveguide **610D1** drops an information channel propagating at a wavelength region of  $\lambda_1$ . During a second reflection of stabilized monochromatic light energy at filter A, waveguide **610A1** can add an information channel propagating at a predefined wavelength region of  $\lambda_1$ .

The filters **A-D** are preferably thin film interference filters that are centered on predefined wavelength regions. However, other filters are not beyond the scope of the present invention. The exemplary filter module **410** provides an efficient mechanism where information channels can be dropped or added or both with minimal signal loss and with minimal hardware. The optical waveguide **610** can be a collimating type waveguide, however, other waveguides are not beyond the scope of the present invention. The number and types of the optical waveguide **610** and filters

**A-D** are not limited to those illustrated in the drawings. Additional or fewer filters and optical waveguides may be employed depending upon the number of information channels that need to be manipulated.

Fig. 7 is a logic flow diagram illustrating a process for increasing a number of information channels carried by an optical waveguide in accordance with an exemplary embodiment of the present invention. Process **700** begins in step **710** in which an OADM device **310** is connected to a SONET network or ADM terminal **220** as illustrated in Fig. 3. However, step **710** may not be necessary if the OADM device **310** is not being combined with a conventional network. In other words, in new optical networks, each OADM device **310** can be connected directly to optical waveguides with out any additional hardware other than a user device such as a computer or LAN, such as user **60E** illustrated in Fig. 3. In such a new optical network embodiment, light energy from a user **60E** would still be stabilized by respective OADM devices **310**.

In step **720**, each OADM device **310** is connected to respective optical waveguides of an optical network such as the optical network **300** as illustrated in Fig. 3. Next, in routine **730**, unstabilized non-monochromatic or monochromatic light energy is transformed into stabilized monochromatic light energy having multiple channels of distinct wavelength regions. The transformation of the light energy into the stabilized monochromatic light energy occurs within the wavelength adapter module **400** as illustrated in Fig. 4.

Subsequently, in routine **740**, multiple information channels propagating at predefined wavelength regions can be dropped, added, or recombined. The dropping, adding, and recombining of information channels typically occurs within the filter module **410** as illustrated in Fig. 4.

In decision step **750**, it is determined whether an information channel needs amplification. If the inquiry to decision step **750** is negative, then the "No" branch is followed to step **770** in which the stabilized monochromatic light energy is propagated between the terminals within the optical network **300** as illustrated in Fig. 3. If the inquiry to decision step **750** is positive, then the "Yes" branch is followed to routine **760** in which one or more information channels are amplified.

Fig. 8 is a logic flow diagram illustrating a routine of Fig. 7 for transforming unstabilized non-monochromatic or monochromatic light energy into stabilized monochromatic light energy in accordance with an exemplary embodiment of the present invention. Routine 730 begins with step 810 in which unstabilized non-monochromatic or monochromatic light energy is fed into a light detecting device 420, such as a photo detector, as illustrated in Fig. 4. Next, in Step 820, the light energy is converted by the light detecting device 420 from optical energy into electrical energy. In step 830, laser device 440 is modulated by the output of the light detecting device 420.

Subsequently, in step 840, the light energy outputted by the laser device 440 is filtered and reflected back into the laser device 440. In other words, for optical feedback assemblies 430 comprising wavelength selective devices such as Bragg gratings, light energy of a predetermined wavelength region is reflected back into the laser device 440. For optical feedback assemblies comprising thin-film interference filters in combination with partial reflecting devices, light energy of a predetermined wavelength is filtered and then reflected back into the laser device 440. Next, in step 850, stabilized monochromatic light energy having a predefined wavelength region is outputted from the laser device 440 through the filtering device 450. The process then returns to routine 740 of Fig. 7.

Fig. 9 is a logic flow diagram of routine 740 of Fig. 7. Routine 740 begins with step 910 in which light energy from the wavelength adapter module 400 is fed into the filter module 410. In step 920, information channels of stabilized monochromatic light energy having predefined wavelength can be dropped by cascading the light energy between one or more filtering devices A-D disposed in PLC 600 as illustrated in Fig. 6. Next, in step 930, information channels of light energy having predefined wavelength regions can be added by cascading light energy between the one or more filtering devices A-D. It is noted that the drop or add steps 920 or 930 are not necessary for every application. These steps can be eliminated depending on the design of a particular wavelength adapter 400. In step 940, the light energy flowing through the planar light guide circuit 600 can be combined. The process then returns to decision step 750 in Fig. 7.

Fig. 10 is a logic flow diagram of routine 760 of Fig. 7. Routine 760 begins with step 1010 in which unstabilized non-monochromatic or monochromatic light energy having one or more channels of light energy of predefined wavelength regions is fed into a filter module as illustrated in Fig. 5. Alternatively, stabilized monochromatic light energy having one or more channels of light energy of predefined wavelength regions can be fed into the filter module 410. In other words, the amplification routine 760 can be applied to unstabilized non-monochromatic or monochromatic light energy as well as stabilized monochromatic light energy. This means that the OADM device 500 as illustrated in Fig. 5 can be used to amplify conventional light signals such as optical signals travelling in accordance with a SONET protocol in addition to light energy that has undergone wavelength division multiplexing.

In step 1020, information channels of monochromatic light energy having predefined wavelength regions needing amplification can be dropped by cascading the light energy between one or more filtering devices within the filter module 410 as illustrated in Fig. 5. The dropped monochromatic light energy channels can then be fed into a light detecting device 420 of a wavelength adapter module 400. In step 1040, the light detecting device 420 converts the dropped monochromatic channels of light energy into electrical energy. Next, in Step 1050, a laser device 440 is modulated with the electrical energy output of the light detecting device 420.

In Step 1060, the initial laser output is filtered and then reflected back into the laser device 440. Subsequently, in Step 1070, amplified and stabilized monochromatic light energy having a predefined wavelength region is outputted. The monochromatic light energy output is then fed into the filter module 410 as set forth in Step 1080. In Step 1090, the filter 410 outputs the amplified, stabilized, combined monochromatic light energy having one or more information channels of predefined wavelength regions. The process then returns to Step 770 of Fig. 7.

While the present invention can be typically employed in interoffice networks 40 and access networks 300, as set forth in the aforementioned illustrated embodiments, the invention is not limited to these applications and can be used in other areas that require increased information traffic handling in an optical fiber environment. For example, the present invention may be employed in the cable TV

environment, which employs optical fibers. Alternatively, the present invention could be employed in smaller local area networks (LANs).

With the present invention, the number of information channels carried by an optical waveguide is substantially increased. The OADM device of the present invention increases the number of information channels within an optical waveguide by utilizing different wavelength regions of light. Further, the present invention is easily overlaid on existing optical network architectures. Stated simply, the present invention is overlaid on conventional optical network systems such that an information channel operating according to a conventional network protocol is unaffected. Meanwhile, the present invention provides additional channels that do not need to be dependent on the conventional optical network protocol. Additionally, the invention can utilize conventional diode laser technology while improving the output thereof. The OADM device stabilizes the output wavelength region of a conventional diode laser to any specific wavelength region with minimal hardware or structural modifications. And lastly, the present invention is able to amplify one or more specific information channels operating at predefined wavelength regions.

It should be understood that the foregoing relates only to illustrated embodiments of the present invention, and that numerous changes may be made therein without departing from the spirit and scope the invention as defined by the following claims.

## CLAIMS

What is claimed is:

1. An optical add-drop multiplexing (OADM) device comprising:
  - 5 a wavelength adapter module for transforming unstabilized non-monochromatic or monochromatic light energy into one or more channels of stabilized monochromatic light energy having one or more predefined wavelength regions; and
  - 10 a filter module for at least one of dropping, adding, and recombining one or more channels of stabilized monochromatic light energy having one or more predefined wavelength regions, whereby information traffic carried by an optical waveguide is substantially increased.
2. The OADM device of claim 1, wherein the wavelength adapter module further  
15 comprises:
  - a light detector for converting light energy into electrical energy; and
  - a laser device for outputting modulated light energy in accordance with said electrical energy.
- 20 3. The OADM device of claim 1, wherein the wavelength adapter module further comprises an optical feedback assembly coupled to an optical waveguide.
4. The OADM device of claim 3, wherein the optical feedback assembly comprises a  
25 Bragg grating.
5. The OADM device of claim 2, wherein laser device comprises a laser diode initially producing unstabilized non-monochromatic or monochromatic light energy at approximately 1310 or 1550 nm wavelength region prior to stabilization.

6. The OADM device of claim 1, wherein the filter module comprises:  
a planar light guide circuit;  
a plurality of filters disposed adjacent to said planar light guide circuit; and  
a plurality of optical waveguides connected to said planar light guide circuit.
- 5
7. The OADM device of claim 6, wherein each filter comprises a thin film interference filter.
8. The OADM device of claim 1, wherein the OADM device is part of a SONET
- 10 optical network.



9. An optical amplifier comprising:  
a light detector for converting light energy into electrical energy; and  
a laser device for outputting modulated light energy in accordance with said electrical energy.
- 5
10. The optical amplifier of claim 9, further comprising a optical feedback assembly coupled to an optical waveguide.
11. The optical amplifier of claim 10, wherein the optical feedback assembly
- 10 comprises a Bragg grating.

12. An optical network comprising:  
a SONET network; and  
a plurality of optical add-drop multiplexing (OADM) devices connected to a plurality of SONET network terminals;  
5 each OADM device comprising:  
a wavelength adapter module for transforming unstabilized non-monochromatic or monochromatic light energy into one or more channels of stabilized monochromatic light energy having one or more predefined wavelength regions; and  
10 a filter module for at least one of dropping, adding, and recombining one or more channels of stabilized monochromatic light energy having one or more predefined wavelength regions.
13. The optical network of claim 12, wherein the SONET network comprises a protection switching scheme that operates irrespective of the plurality of OADM devices.  
15
14. The optical network of claim 12, wherein each OADM balances information flow by propagating light energy containing information channels through respective optical waveguides connected to each OADM device, whereby a number of information routes between at least one of users and central offices are increased.  
20
15. The optical network of claim 12, wherein the unstabilized non-monochromatic or monochromatic light energy is light energy propagating according to a predefined network protocol.  
25
16. The optical network of claim 15, wherein the unstabilized non-monochromatic or monochromatic light energy is light energy propagating according to a synchronous optical network (SONET) protocol.

17. The optical network of claim 12, wherein the wavelength adapter module further comprises:
- a light detector for converting light energy into electrical energy; and
  - a laser device for outputting modulated light energy in accordance with said
- 5 electrical energy.
18. The optical network of claim 12, wherein the wavelength adapter module further comprises a optical feedback assembly coupled to an optical waveguide.
- 10 19. The optical network of claim 18, wherein the optical feedback assembly comprises a Bragg grating.
20. The optical network of claim 17, wherein laser device comprises a laser diode initially producing unstabilized non-monochromatic or monochromatic light energy at
- 15 approximately 1310 or 1550 nm wavelength region prior to stabilization.
21. The optical network of claim 17, wherein laser device comprises a Fabry-Perot laser initially producing unstabilized non-monochromatic or monochromatic light energy at approximately 1310 or 1550 nm wavelength region prior to stabilization,
- 20 said Fabry-Perot laser producing stabilized light energy at a predefined wavelength region within a spectral grid, said grid comprises a portion of either said 1310 or 1550 nm wavelength region.
22. The optical network of claim 12, wherein the filter module comprises:
- 25 a planar light guide circuit;
  - a plurality of filters disposed adjacent to said planar light guide circuit; and
  - a plurality of optical waveguides connected to said planar light guide circuit.
23. The optical network of claim 22, wherein each filter comprises a thin film
- 30 interference filter.

24. The optical network of claim 12, wherein the wavelength adapter module comprises a semiconductor laser in communication with a wavelength-specific reflector for stabilizing output of said laser, said reflector being part of a single mode optical circuit that propagates light energy between said reflector and an exit port of  
5 said laser, and said wavelength adapter module and said filter module form a unitary structure.

25. The optical network of claim 12, wherein said single mode optical circuit comprises a fiber optic cable.

26. A method for increasing a number of information channels carried by an optical waveguide, comprising the steps of:
- transforming unstabilized non-monochromatic or monochromatic light energy into a plurality of channels of monochromatic light energy having one or more predefined wavelength regions with an optical add-drop multiplexing (OADM) device;
  - dropping one or more channels of stabilized monochromatic light energy having one or more predefined wavelength regions with the OADM device;
  - adding one or more channels of stabilized monochromatic light energy having one or more predefined wavelength regions with the OADM device; and
  - recombining one or more channels of stabilized monochromatic light energy having predefined wavelength regions with the OADM device, whereby information traffic carried by an optical waveguide is substantially increased.
27. The method of 26, further comprising the step of connecting the OADM device between a terminal and an optical network.
28. The method of claim 26, wherein the transforming step further comprises the steps of:
- converting the light energy into electrical energy;
  - modulating a laser device with the electrical energy; and
  - outputting light energy from the laser device.
29. The method of claim 28, wherein the converting step comprises channeling the light energy into the input of a light detector.
30. The method of claim 28, wherein the converting step comprises channeling the light energy into the input of a photodetector.
31. The method of claim 28, wherein the modulating step comprises modulating a laser diode.

32. The method of claim 31, wherein the laser diode initially produces unstabilized non-monochromatic or monochromatic light energy at approximately 1310 or 1550 nm wavelength region before being stabilized.
- 5 33. The method of claim 28, further comprising the steps of:  
filtering the light energy generated by the laser device;  
reflecting filtered light energy of a predefined wavelength region back into the laser device;  
stabilizing the laser device with the filtered light energy; and  
10 outputting stabilized monochromatic light energy of the predefined wavelength region from the laser device matching the wavelength region of the reflected filtered light energy.
- 15 34. The method of claim 33, wherein the filtering and reflecting steps comprise filtering and reflecting the light energy with a grating.
35. The method of claim 34, wherein the grating filter comprises a Bragg grating.
- 20 36. The method of claim 26, wherein the dropping and adding steps further comprise the step of transmitting at least one of non-monochromatic and monochromatic light energy through a planar light guide circuit.

37. The method of claim 36, wherein the transmitting step includes cascading the light energy through a planar light guide circuit, said cascading comprising the steps of:

- 5 filtering at least one of the non-monochromatic and monochromatic light energy within the planar light guide circuit;
- propagating filtered stabilized monochromatic light energy away from the planar light guide circuit;
- propagating stabilized monochromatic light energy to the planar light guide circuit; and
- 10 reflecting the stabilized monochromatic light energy between one or more filters disposed within the planar light guide circuit.

38. The method of claim 37, wherein the filtering step further comprises filtering the stabilized monochromatic light energy with one or more thin film interference filters.

15

39. The method of claim 37, wherein the step of propagating filtered stabilized monochromatic light energy away from the planar light guide circuit further comprises channeling the filtered stabilized monochromatic light energy within an optical waveguide.

20

40. The method of claim 37, wherein the step of propagating stabilized monochromatic light energy to the planar light guide circuit further comprises channeling the stabilized monochromatic light energy within an optical waveguide.

25 41. The method of claim 26, further comprising the step of overlaying a plurality OADM devices on an optical network to increase the number channels carried by the optical network.

42. The method of claim 26, further comprising the step of overlaying a plurality  
30 OADM devices on a synchronous optical network (SONET) to increase the number channels carried by the optical network.

43. The method of claim 42, wherein the SONET network comprises a protection switching scheme that operates irrespective of the plurality of OADM devices.

44. The method of claim 32, wherein each OADM balances information flow by  
5 propagating light energy containing information channels through respective optical waveguides connected to each OADM device, whereby a number of information routes between at least one of users and central offices are increased.

45. The method of claim 26, wherein the unstabilized non-monochromatic or  
10 monochromatic light energy is light energy propagating according to a network protocol.

46. The method of claim 45, wherein the unstabilized non-monochromatic or  
15 monochromatic light energy is light energy propagating according to a synchronous optical network protocol.



47. A method for amplifying light energy comprising the steps of:  
converting unstabilized or stabilized light energy into electrical energy;  
modulating a laser device with the electrical energy; and  
outputting light energy from the laser device.

5

48. The method of claim 47, further comprising the steps of:  
filtering the light energy generated by the laser device;  
reflecting the filtered light energy of a predefined wavelength region back into  
the laser device;

10

stabilizing the laser device with the reflected light energy; and  
outputting stabilized monochromatic light energy of the predefined  
wavelength region from the laser device matching the wavelength region of the  
reflected filtered light energy.

15

49. The method of claim 47, wherein the converting step comprises channeling the  
light energy into the input of a light detector.

50. The method of claim 47, wherein the converting step comprises channeling the  
light energy into the input of a photodetector.

20

51. The method of claim 47, wherein the modulating step comprises modulating a  
laser diode.

52. The method of claim 47, wherein the laser diode initially produces unstabilized  
non-monochromatic or monochromatic light energy at approximately 1310 or 1550  
nm wavelength region before being stabilized.

25

53. The method of claim 47, further comprising the step of propagating single mode  
light energy outputted by said laser device within a planar lightguide circuit.

30

54. The method of claim 48, further comprising the steps of:  
outputting the light energy from a facet of a semiconductor gain medium; and  
propagating the light energy through a single mode waveguided pathway  
before and after the reflecting step.
- 5 55. A method for amplifying monochromatic light energy of an optical network,  
comprising:  
propagating monochromatic light energy having a plurality of predefined  
wavelength regions into a filter module;  
filtering the monochromatic light energy into separate wavelength regions  
10 with the filter module;  
feeding the separated light energy into a semiconductor device;  
amplifying the separated light energy with the semiconductor device; and  
feeding the amplified light energy back into the filter module.
- 15 56. The method of claim 55, wherein the semiconductor device comprises an active  
gain medium that undergoes stimulated emissions.
57. The method of claim 55, wherein the semiconductor device comprises a laser  
diode, the amplifying step further comprises the steps of:  
20 converting light energy into electrical energy; and  
outputting light energy from the laser diode.
58. The method of claim 55, further comprising the steps of:  
filtering the light energy generated by the laser diode;  
25 reflecting some filtered light energy of one of the plurality of predefined  
wavelength regions back into the laser diode;  
stabilizing the laser diode with the filtered light energy; and  
outputting monochromatic light energy at the one of the plurality of  
predefined wavelength regions from the laser diode matching the wavelength region  
30 of the reflected filtered light energy.

59. The method of claim 55, further comprising the step of propagating at least some portion of the light energy through a segment of a single mode optical pathway of a planar lightguide circuit.

5

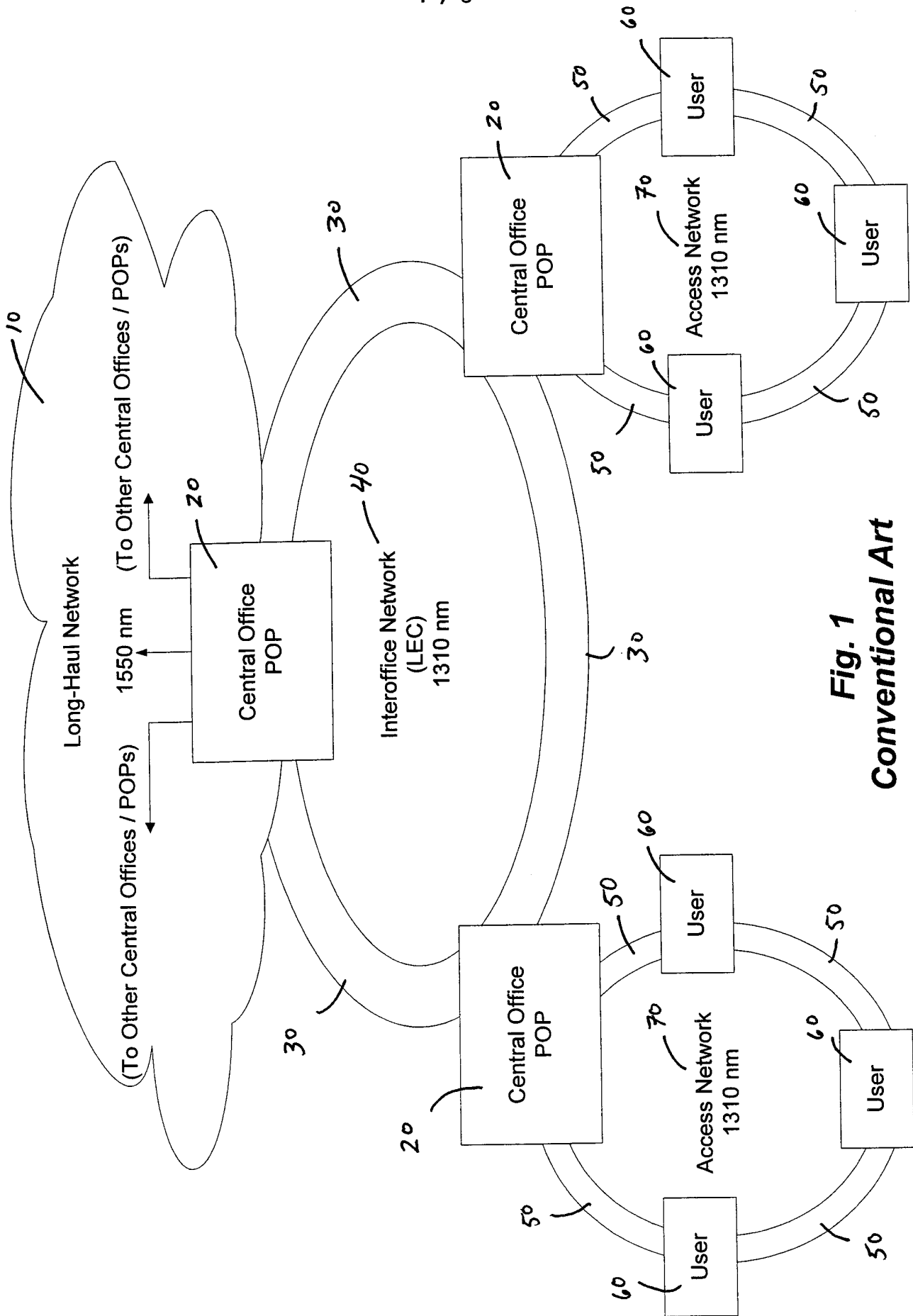

**Fig. 1**  
**Conventional Art**

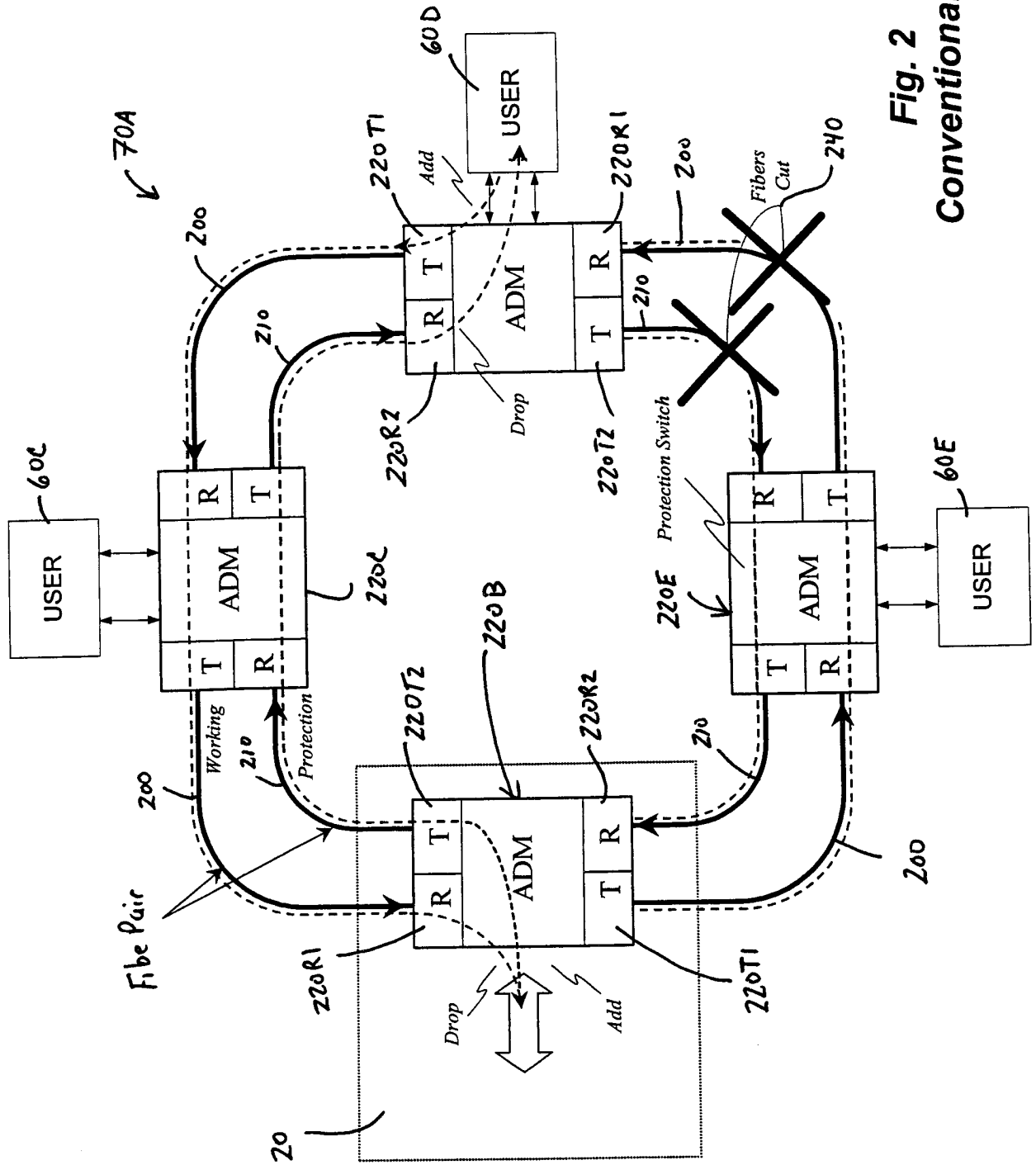

Fig. 2  
Conventional Art

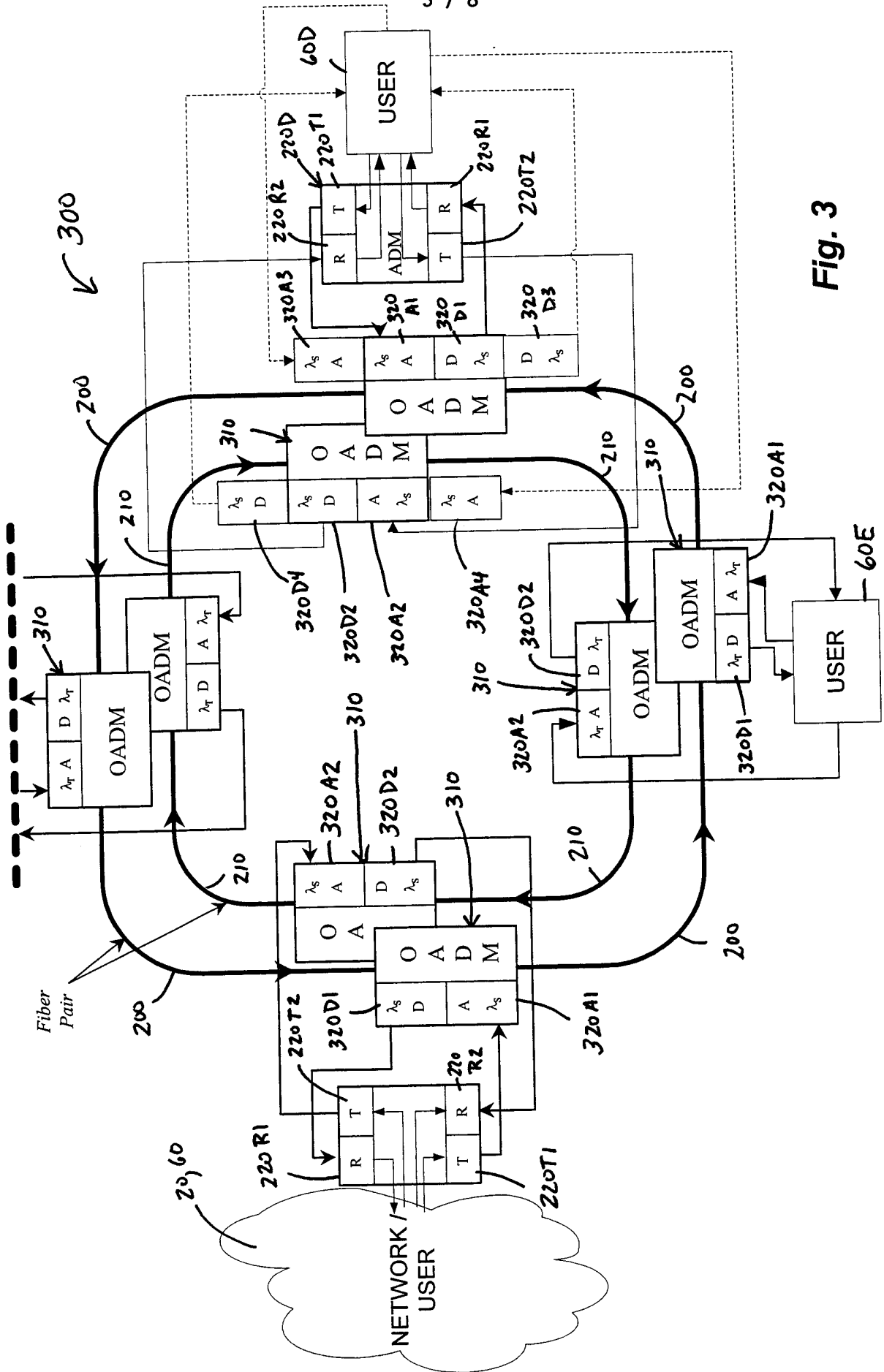

Fig. 3

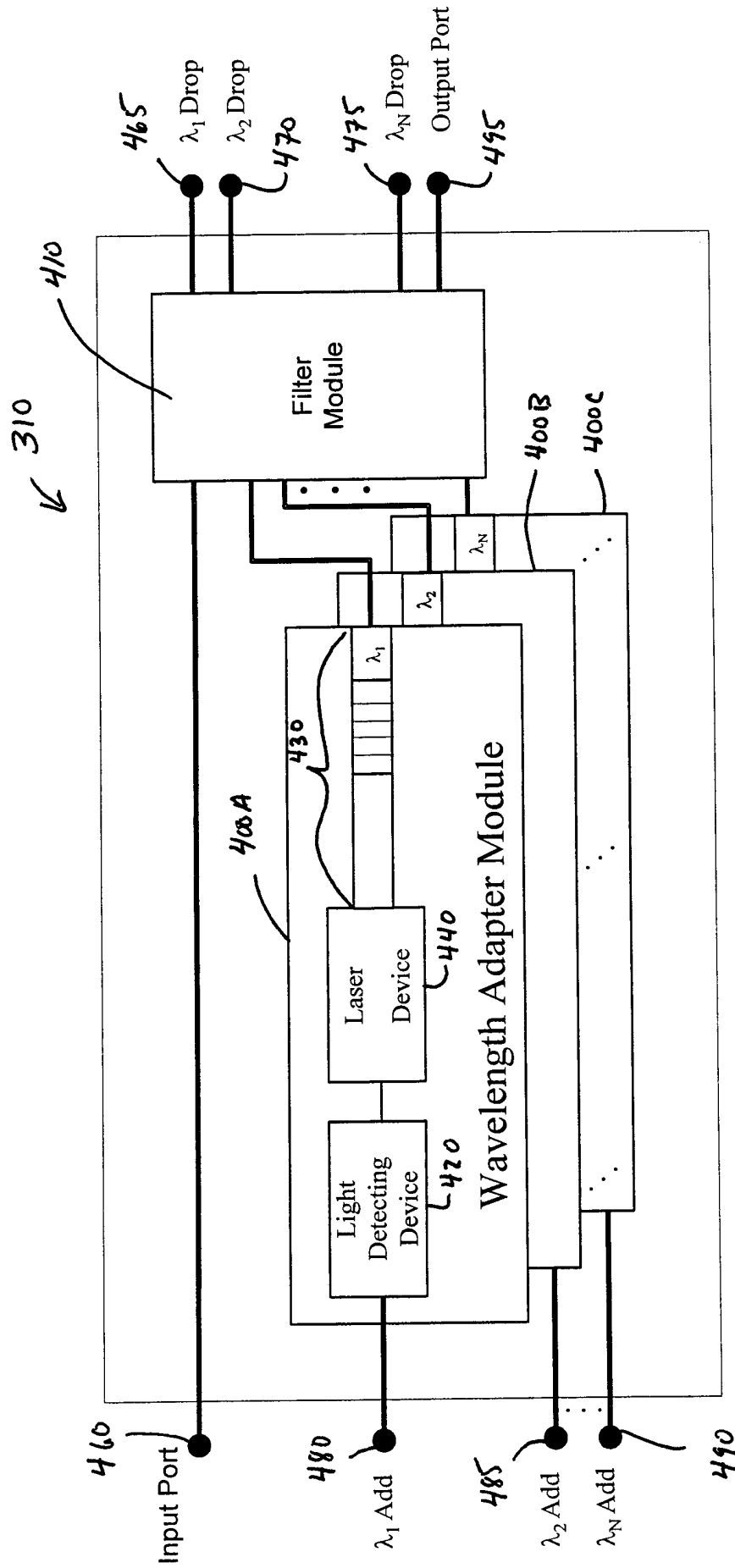

Fig. 4

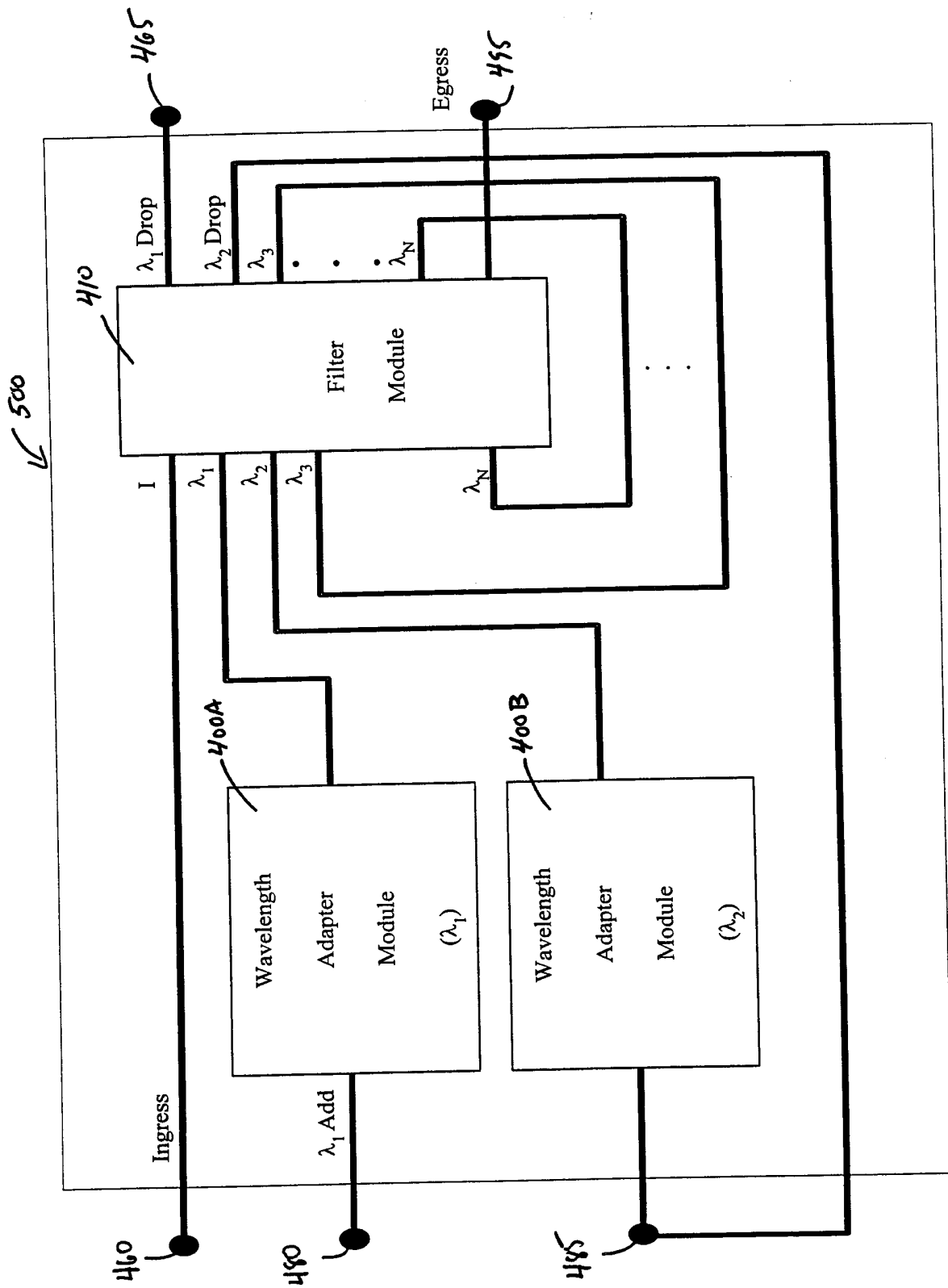

Fig. 5



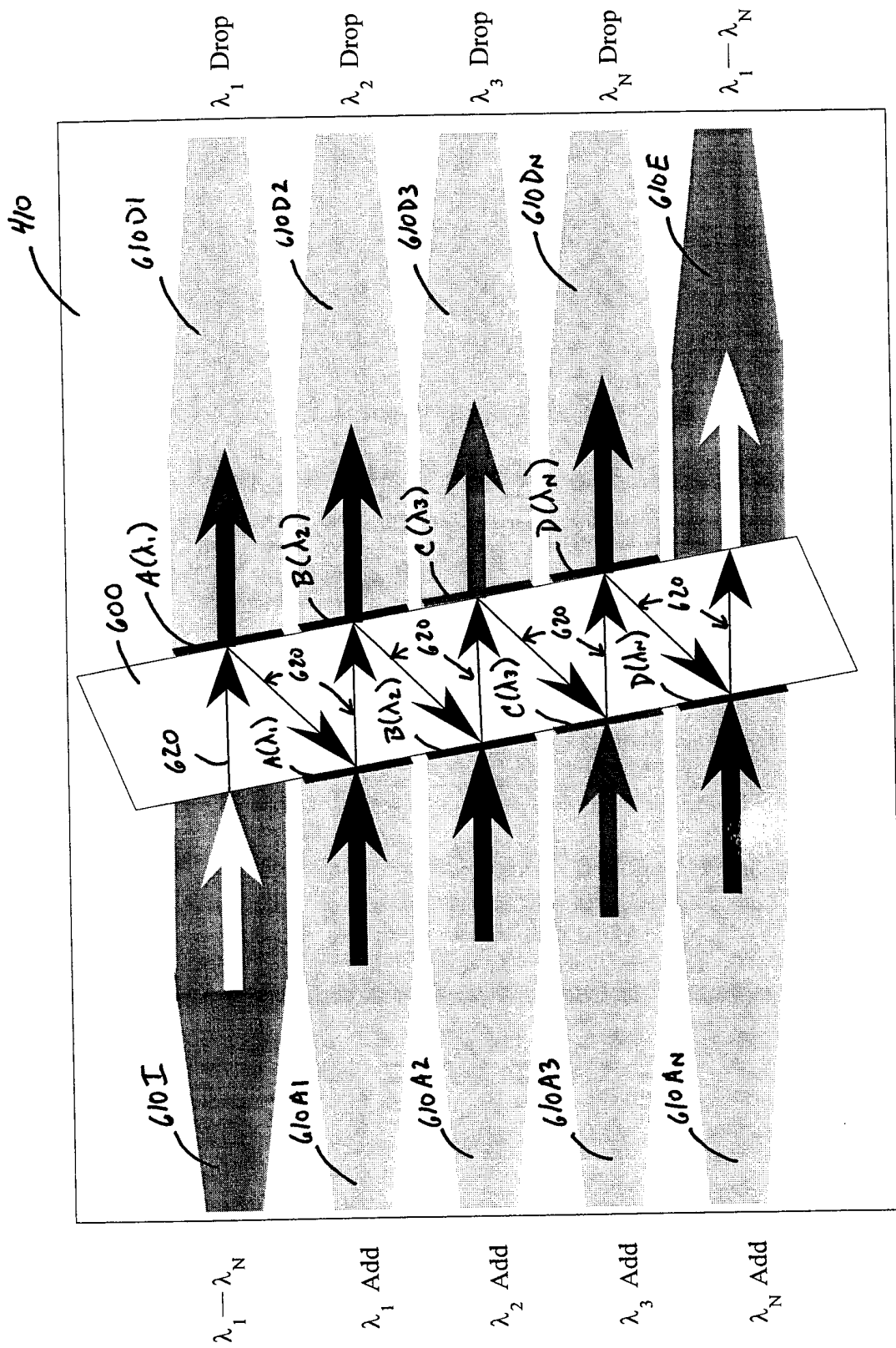

Fig. 6

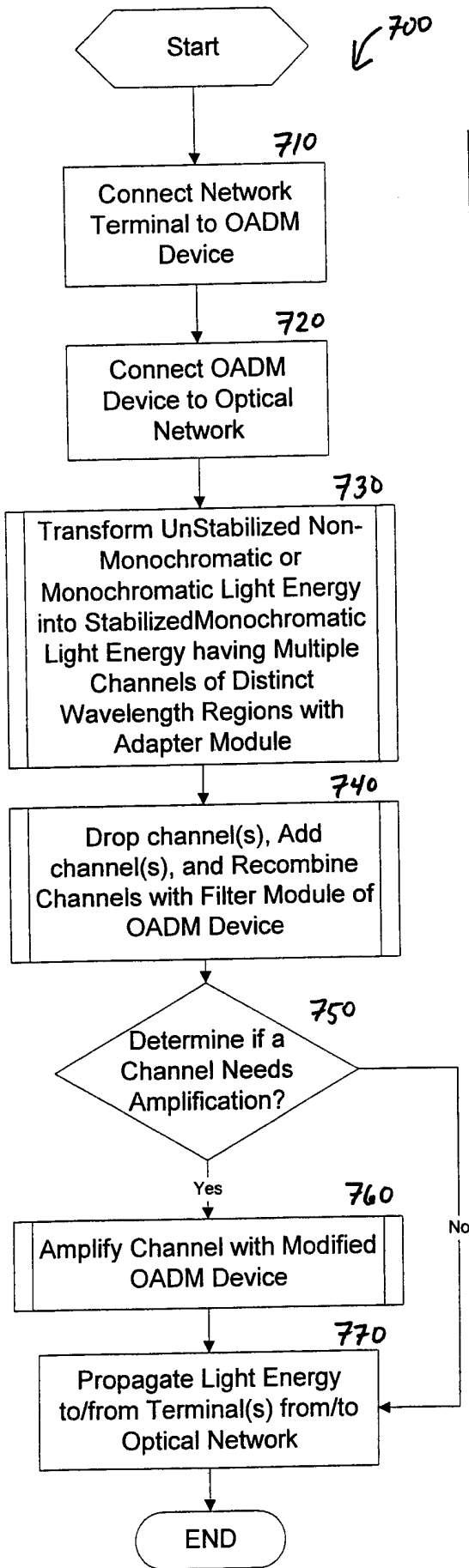

Fig. 7

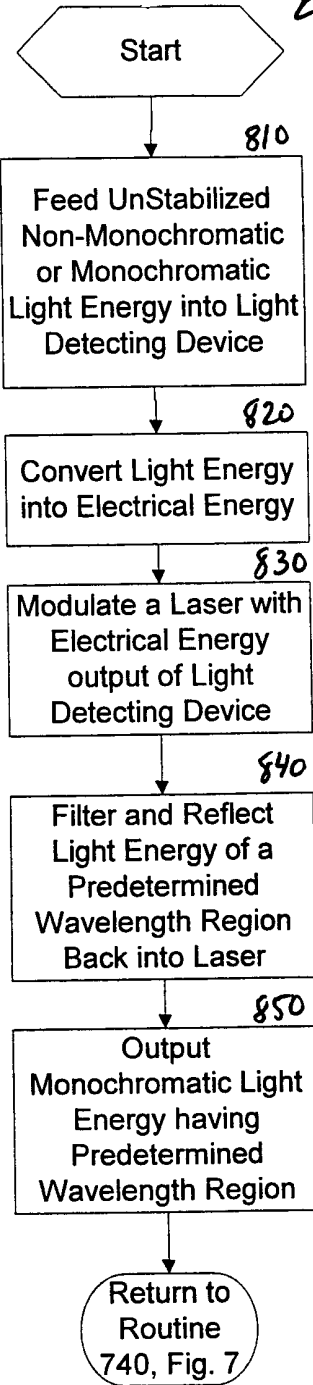

Fig. 8

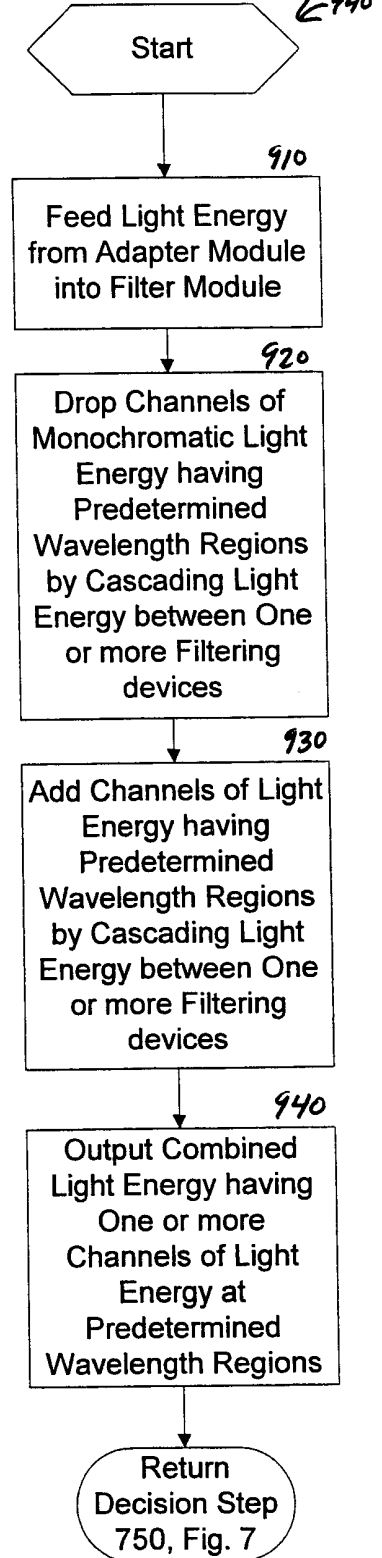

Fig. 9

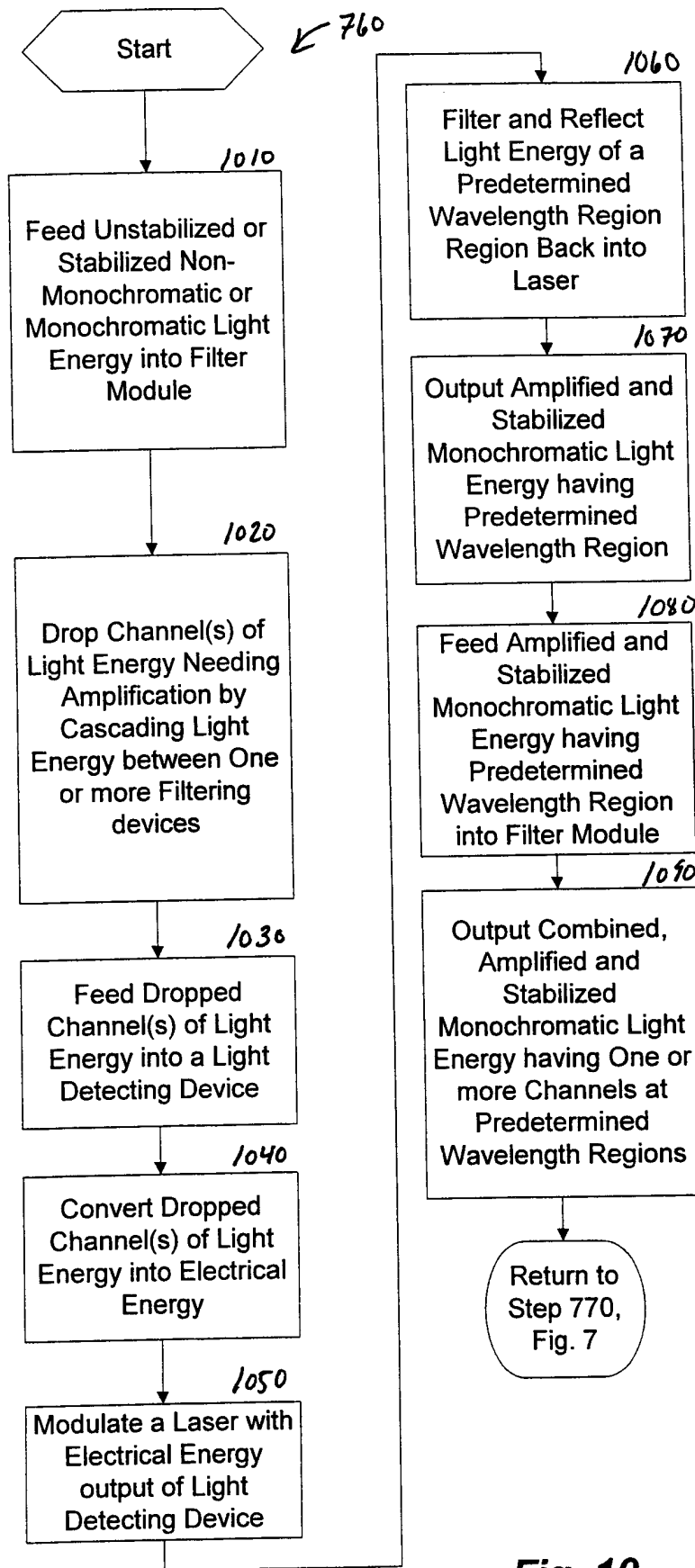

Fig. 10