

(19)
(12)

(KR)
(A)

(51) 。 Int. Cl.⁷
B65D 19/34

(11)
(43)

2003-0057504
2003 07 04

(21) 10-2003-0038973
(22) 2003 06 17

(71) 105-703

(72) 105-703

(74)

:

(54)

가

가 , 가

가

2

, , , EPS,

1

2

가

3

, 가 가

, .
, , ,

, 가

, 가

, 가

, ,

1

1
nner)

(11) ,

(12)(ru

, (11)
(honey pad)

(normal stress)

, 가 가 가 ,

, (12)

, 가

EPS(Expandable Polystyrene resin),

, EPS,

(11)

(12)

(14)

1

, 1

1

2

(21)가

2

, (12)

3

, 가

(21)

, (22)가
(22)

26) ,
ss)

, 3

(27)

, 가
, 가

1

(25),

2 ((shere stre

(21) (25)(26)(27) ,
 (shere stress) 가 ,
 (25)(26)(27) (22)
 (21) (22) ,
 가 ,
 (21) (23)가 ,
 2 , 2 ,
 3 (21) .
 3 (21) (31) , (31)
 (32) , (33)가 2 ,
 (21) (31)가 ,
 (11) , 가 .
 , , 가 가 .
 4 EPS가 .
 4 , 1 (43) EP
 S 가 2 (44) , EPS
 S(42) 가 , (43) (41) , 2 (44) EP
 가 , EPS(42) (41)
 , (22) (22)가
 2 2 .
 EPS(42)가 , (41)가 가 ,
 , (41)가 , EPS(42) 가
 , 가 (12)
 (12) (41) EPS(42) , 가 25 ± 4
 (41) , 가 32 ± 4 EPS(42)
 , 가
 , 가
 , 가 EPS(42) , 가 , 1 가 (43)
 (41) .
 , , EPS(42)
 , 가 가 가

1

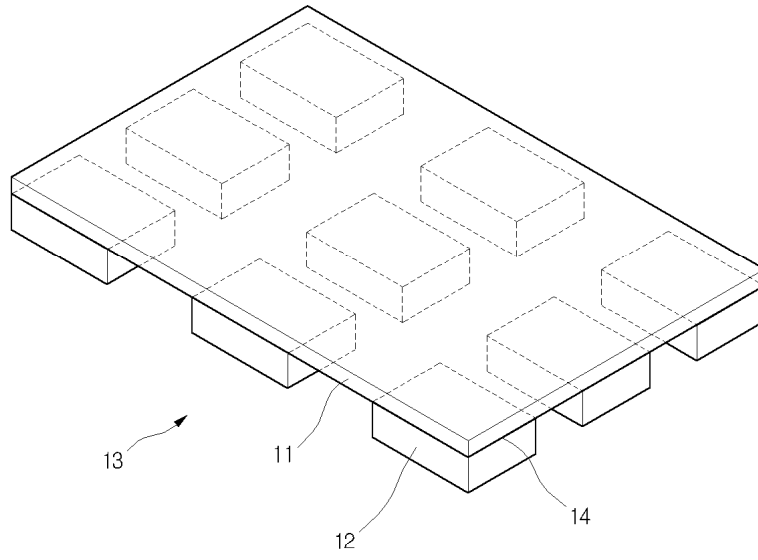

2

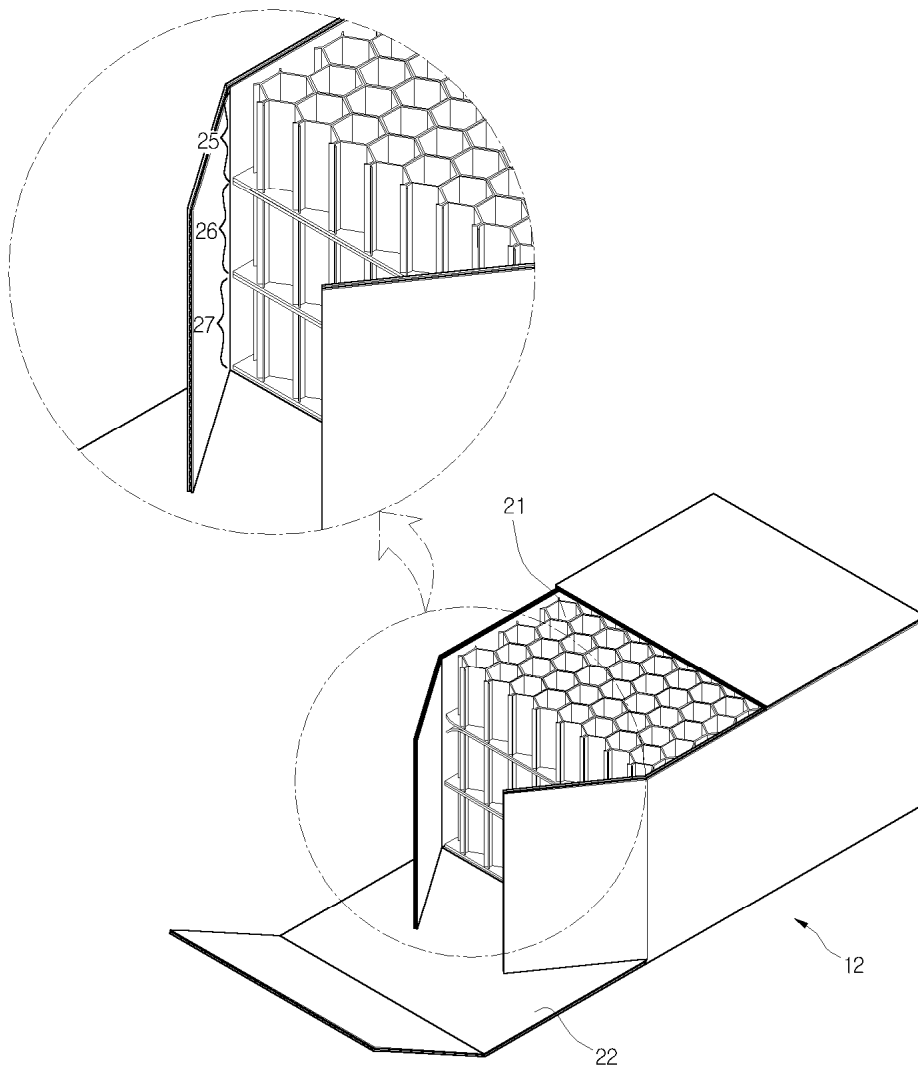

3

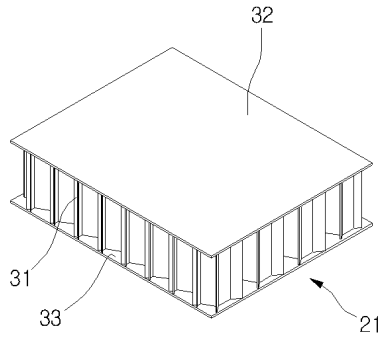

4

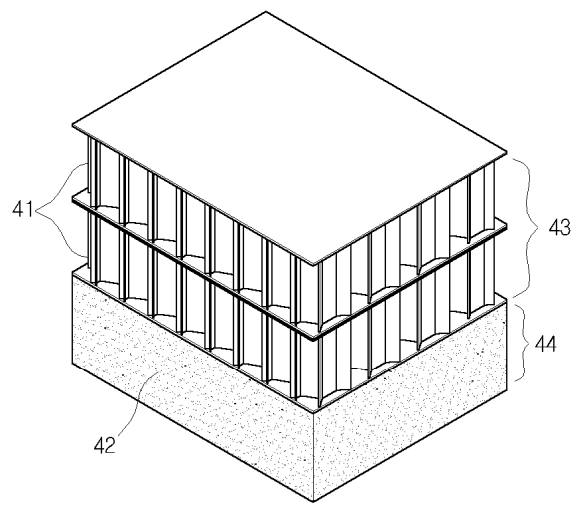

5

