

(No Model.)

2 Sheets—Sheet 1.

G. B. BOOMER.

FILTER PRESS.

No. 301,794.

Patented July 8, 1884.

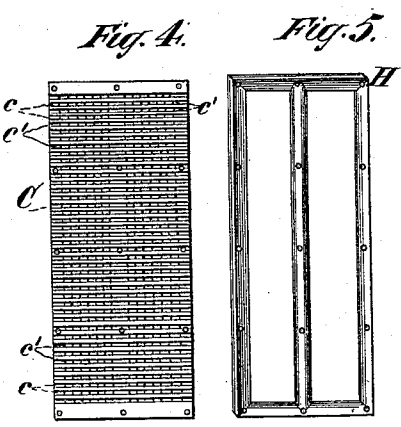
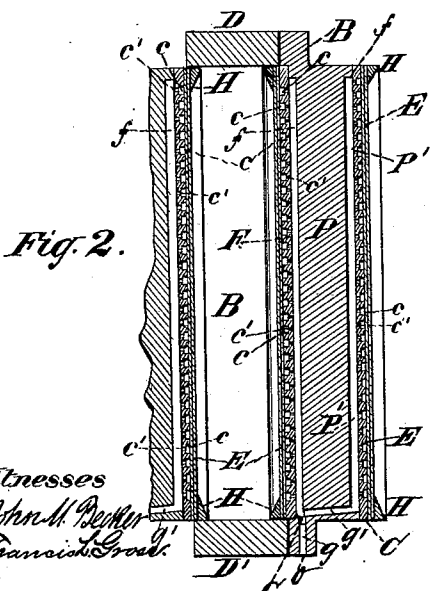
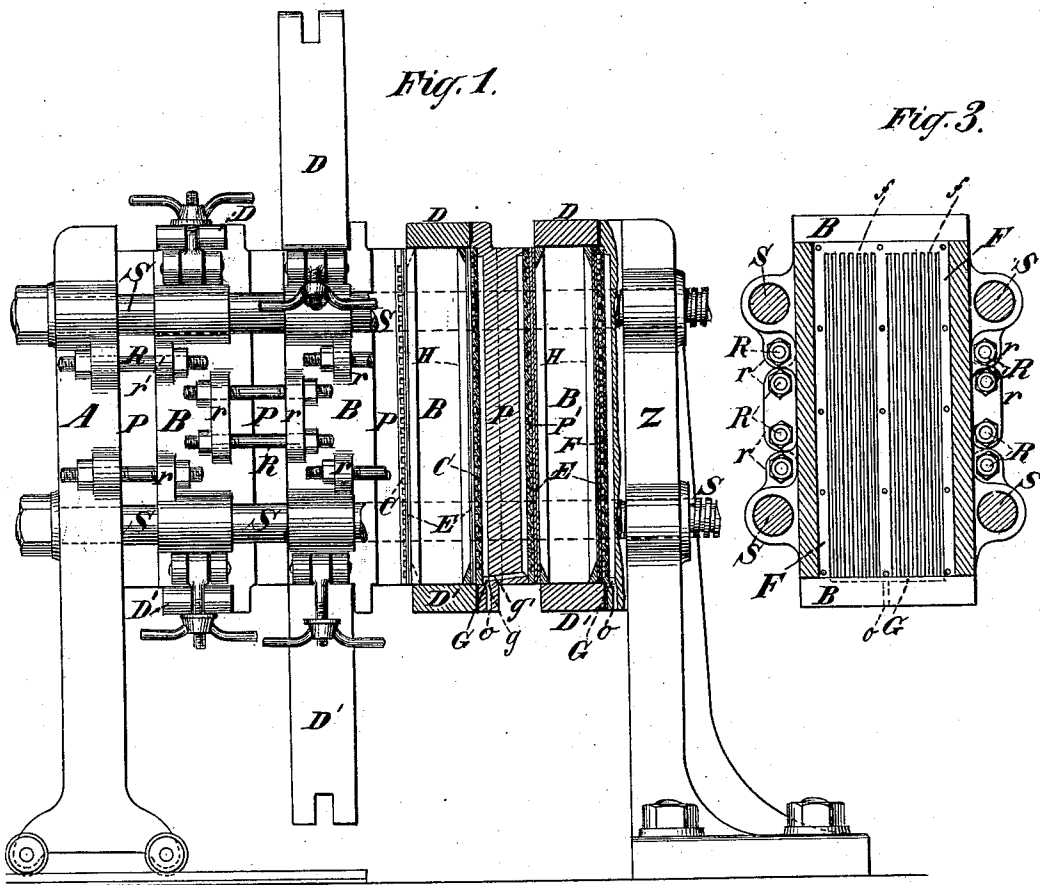

Witnesses
 E. J. M. Decker
 Francis D. ...

George B. Boomer
 per [Signature]
 Attorneys.

(No Model.)

2 Sheets—Sheet 2.

G. B. BOOMER.
FILTER PRESS.

No. 301,794.

Patented July 8, 1884.

Fig. 1

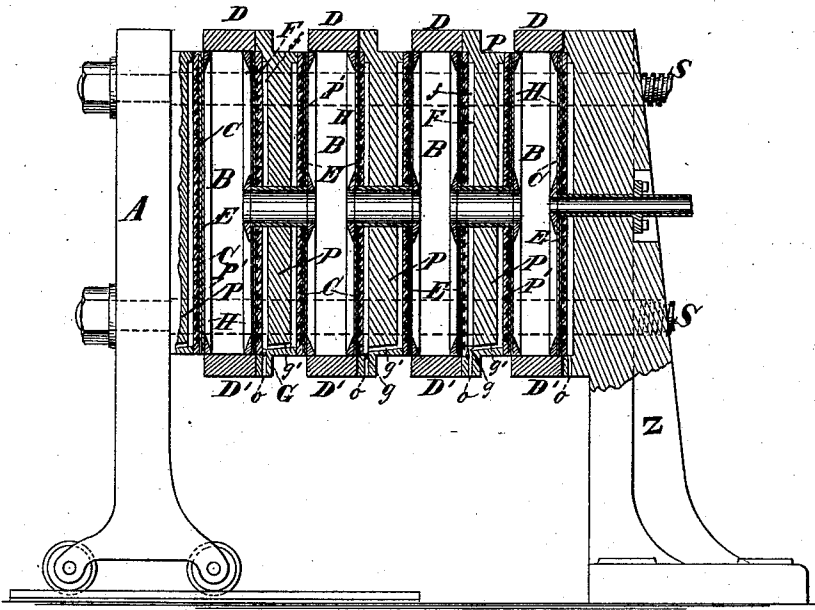
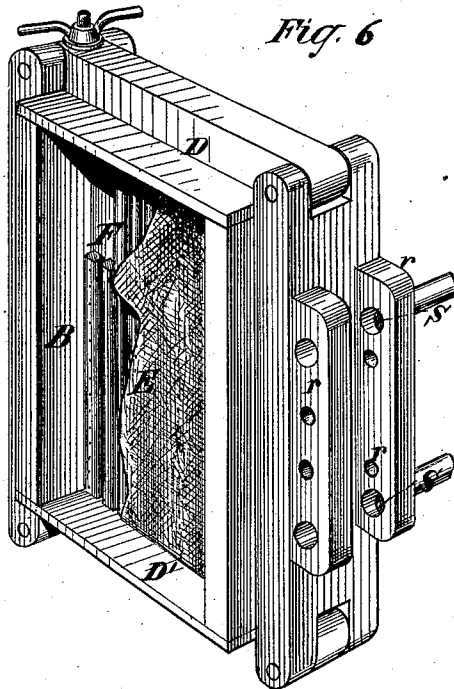

Fig. 6



Witnesses
E. John M. Beckler
Francis S. Gross.

Inventor
George B. Boomer
 per *W. J. Saw*
 Attorneys

UNITED STATES PATENT OFFICE.

GEORGE B. BOOMER, OF MOUNT PLEASANT, NEW YORK.

FILTER-PRESS.

SPECIFICATION forming part of Letters Patent No. 301,794, dated July 8, 1884.

Application filed May 3, 1884. (No model.)

To all whom it may concern:

Be it known that I, GEORGE B. BOOMER, of Tarrytown Heights, in the town of Mount Pleasant, county of Westchester, State of New York, have invented a new and useful Improvement in Filter-Presses, of which the following is a full, clear, and exact description, reference being had to the accompanying drawings, making a part of this specification.

My invention relates to improvements in presses for separating liquids from solids, and is designed to produce a press which can be instantly filled with material, quickly and easily discharged, and in which the material is closely confined while pressing. It also applies to presses usually denominated "filter-presses," where the material is of so soft or liquid a nature that the press can be filled with a pump.

In the drawings illustrating my improvements, in which like letters indicate like parts, Figure 1 is a side view of a press containing my improvement, showing two boxes in section, and the upper and lower doors of one of the boxes opened. Fig. 2 is an enlarged sectional view of a box and its plunger, showing the plate, cloth, and frame, arranged on the inner face of the box, and on the plunger when ready for use. Fig. 3 is a view of the inner face of the box, showing the grooves on the same. Fig. 4 is a view of the grooved plate fitting over the face of the box. Fig. 5 is a view of the frame for holding the cloth in position. Fig. 6 is a view of the inner face of the box in perspective, showing the arrangement of the same with wooden slats. Fig. 7 is a sectional side view of a press adapted to be filled by means of a pump, and containing my improvements.

My invention consists of a novel arrangement and construction of the telescoping boxes in a horizontal position, with doors on the upper and lower sides through which the boxes are charged and discharged, and of the arrangement of the cloth on the face of the box and on the plunger, so that it will remain in place when the box is emptied, and yet can easily be removed to be cleaned or renewed, and in the arrangement, with the ordinary filter-press filled by means of a pump, of the telescoping boxes to more completely extract the liquid. The boxes B are preferably rect-

angular in shape, having the greatest length in a perpendicular direction; but the shape of the box may be varied, and the top and bottom may be arched, if desired; but in all cases the vertical sides of the box should be straight to allow the cake or the material, after having been pressed, to drop out through the bottom, and to facilitate the discharge of the box it may be a little wider at the bottom than at the top. The upper and lower sides of the box, or the top and bottom, are formed by doors D D', shown open and closed in Fig. 1, which open outward, and are capable of being securely and tightly closed to resist the pressure when the press is in operation. These doors are generally hinged to one of the vertical sides of the box, and are secured by any suitable fastening to the opposite side. On the back of each box is the plunger P adapted to slide into the succeeding box on the press. The face of the plunger and the inner face of the box against which the material is pressed may be constructed in a variety of ways to adapt the press to different kinds of work; but for general use I prefer the following mode of construction.

On the inner face, F, of each box are a number of narrow vertical grooves, *f*, extending from near the upper edge of the face across or through the lower edge, as shown in Fig. 3. Similar vertical grooves are provided on the face P' of the plunger; but instead of extending across the lower edge they terminate in a channel or ridge on the bottom of the face, from which a groove, *g'*, conducts the liquid to the common outlet *o*. Against this grooved face F of the box is placed a thin metallic plate, C, Fig. 4. As will be seen from the drawings, this plate C has a series of grooves, *c*, running horizontally across the same, or at right angles to those on the face F. This plate C is perforated by a number of small holes, *c'*, corresponding in position with the vertical grooves on the face F, and opening into the horizontal grooves *c*. The grooves *c* in the plate are made very narrow or fine, and the edges rounded so as not to cut or injure the cloth.

Over the grooved side of the plate C is placed the filter-cloth E, which is held in position and against the plate by the frame H, Fig. 5, screwed or otherwise attached to the same. The frame H tightly secures the cloth

at the edges, and, if necessary, in the middle, and prevents the cloth from being disturbed or withdrawn when the press is run back and the cake is dropped out of the box.

5 In the arrangement described above, the plate C, cloth E, and frame H are attached together, the grooved side of the plate being next to the cloth, and then by means of grooves in the sides of the box slid through the bottom
10 door into their place in front of and against the inner face, F, of the box, as shown in Fig. 2. By this method of construction the cloth may readily be removed from the box when it is necessary to cleanse or renew it; but the
15 plate C may be fastened directly to the face of the box, and the several parts attached together in any convenient manner, so as to be easily removed. The outside bars of the frame H, as shown in the drawings, are beveled or
20 made thick on their outer edges, so that the pressure in pressing will tend to force them out against the sides of the box, preventing the material from being forced between the plunger and the sides of the box. For the same
25 reason the frame is made to accurately fit the box. This frame not only holds the cloth in place, but also presses the material toward the center away from the sides of the box, and makes the cake thinner on its edges, thereby
30 squeezing the edges of the cake dry, and also greatly reducing the strain on the sides and doors of the boxes.

To the face of the plunger, as is shown in Fig. 2, are secured a metallic plate, filter-cloth, and frame, similar in all respects to those on
35 the inner face of the box, so that the construction of the pressing-surface of the plunger and of the box is the same.

When the material is of a more pliant nature, like the pomace from apples, fish-refuse, and refuse from slaughter-houses, the metal plate C and frame H may be dispensed with, and the face of the box and of the plunger constructed with narrow ribs of wood, as
40 shown in Fig. 6, to which the cloth is directly attached by nailing or otherwise. The arrangement of the box and the plunger thus constructed on the press will be best understood from the drawings, Fig. 1 of which
45 shows a number of boxes in position. As shown in this figure, on the head-piece A is placed the plunger which engages with the first box, and on the back of each box is the plunger for the succeeding box, the last box being
50 secured to the fixed end piece, Z. As will be seen from Fig. 2, the face of the plunger is introduced just within the open edge of the box, so as to inclose the space within and to confine the material or charge in the box. The
55 plunger is held in this position and prevented from separating from the box by means of the bolts or rods R, Fig. 1, which pass through ears r on the sides of the box, and are provided on each end with nuts, which can be ad-
60 justed as desired. As these rods rest loosely in the ears, they readily slide back and forth in the same, and offer no obstruction to the

free movement of the plunger within the box; but by the contact of the nuts on their ends with the ears they prevent the plunger with-
70 drawing entirely from the box. The open end of the box is thus perpetually closed by the plunger, and communication is had with the interior only at the top and bottom by means of the doors. The boxes and plungers
75 thus constructed and arranged in connection with each other are hung or supported on the rods S of the press, as shown in Fig. 1, so that they will readily slide back and forth on the same. These rods in the press illustrated in
80 the drawings are secured at one end to a movable head-piece, A, which rests upon rollers, as shown, and pass at the other end through a fixed end piece, Z, beyond which they are connected with the pinions and
85 wheels from which the power to work the press is derived.

The arrangement of the rods and of the head and end pieces may be varied, and I do not wish to confine myself to the screw-press
90 shown, as the hydraulic or any other kind of power may be employed, if desired.

The boxes having been put together, as shown and described, the operation of the press is as follows: The press being extended,
95 as is seen in Fig. 1, so that each plunger is just within the open edge of its box, as shown in section in Fig. 2, the door in the top or upper side is opened and the box filled with the material to be pressed. The door is then closed
100 and securely fastened, and the press run together. As the liquid is pressed from the material it is forced through the filter-cloths on the box and on the plunger, and collects in the horizontal grooves c on the plates C, from
105 whence it passes by means of the holes c' through the plates into the vertical grooves on the inner face of the box and on the plunger. In the former case the liquid flows down the grooves f into a channel, G, formed in the
110 frame of the box below the face F, and escapes by means of the groove g through the outlet o into a trough placed below the press. The liquid in the grooves on the plunger flows into the channel or ridge on the face of the plunger,
115 before described, and passes out by means of a groove, g', through the common outlet o. After all the liquid is extracted the press is run back, the doors at the top and bottom of the box are opened, and the dry cake is
120 dropped out through the bottom, and may be received in a car or other receptacle run under the press for the purpose. The lower door is then closed, the box refilled through the top, and the process of pressing repeated.
125

As will be seen from the above description the process of charging and discharging the boxes is a very easy and rapid one.

By a simple arrangement the doors of all the boxes may be opened and closed at one
130 operation, and the boxes may be filled simultaneously. As in pressing the same pressure is exerted in all the boxes alike it follows that the liquid is extracted in all in the same time,

and when the press is run back the cakes in all the boxes are ready to be discharged.

When the press is to be used as a filter-press, with material of so soft or liquid a nature that it can be pumped into the boxes, a hole or passage is made through the back of the boxes and through the plungers, as shown in Fig. 7, so as to connect the interior of the boxes with one another. This hole or passage extends through the plates C and through the filter-cloths, and is provided with a thimble or other device, so as to prevent the liquid from passing back of the filter-cloths or anywhere but into the boxes. In this construction the frame H should be so made as to hold the cloth tightly around the hole or passage.

The first or stationary box being connected with the pump by means of a supply-pipe, the operation is as follows: The plungers being drawn out to their full extent, and the top and bottom doors of the boxes closed and secured, the semi-liquid material is pumped in until the boxes become filled with the solid portion, the liquid portion having been forced through the filtering-cloths and passed off. When sufficient material has been forced into the boxes, a valve in the supply-pipe is closed and the press put in operation. When the material is thoroughly pressed, it is discharged as before described. Thus with my system of telescoping boxes when applied to a filter-press, after the power of the pump to extract the liquid has been exhausted, I am enabled to continue the process of pressing or filtering, and still further separate the liquid from the material in the boxes.

What I claim is—

1. In a press for separating liquids from solids, telescoping boxes arranged in a horizontal position, and provided with doors at the top and bottom, constructed substantially as described, and for the purposes set forth. 40

2. In combination with horizontally-arranged telescoping boxes having doors at the top and bottom, the plates C, grooved on their faces and perforated with holes in the grooves, the filter-cloths S, and frames H, substantially as described, and for the purposes set forth. 45

3. In combination with the telescoping boxes arranged in a horizontal position, the plates C, cloths S, and frames H, connected together and arranged to slide in grooves or their equivalents in the box, substantially as set forth. 50

4. In combination with the horizontally-arranged telescoping boxes having doors at the top and bottom, the filter-cloths attached to the face of the box and to the plunger, substantially as and for the purposes set forth. 55

5. In a filter-press, the telescoping boxes connected by a passage through which the material can be forced into all the boxes by a pump, as and for the purposes set forth. 60

6. In combination with the horizontally-arranged telescoping boxes provided with connecting-passages, so as to be filled by means of a pump and having doors at the top and bottom, the plates C, cloths S, and frames H, constructed substantially as described and for the purposes set forth. 65 70

GEO. B. BOOMER.

Witnesses:

FRANCIS L. GROSS,
E. JOHN M. BECKER.