

D. F. MAGEE.
CLOCK CONTROLLED BELL STRIKING MECHANISM.
APPLICATION FILED JUNE 24, 1910.

993,453.

Patented May 30, 1911.

2 SHEETS—SHEET 1.

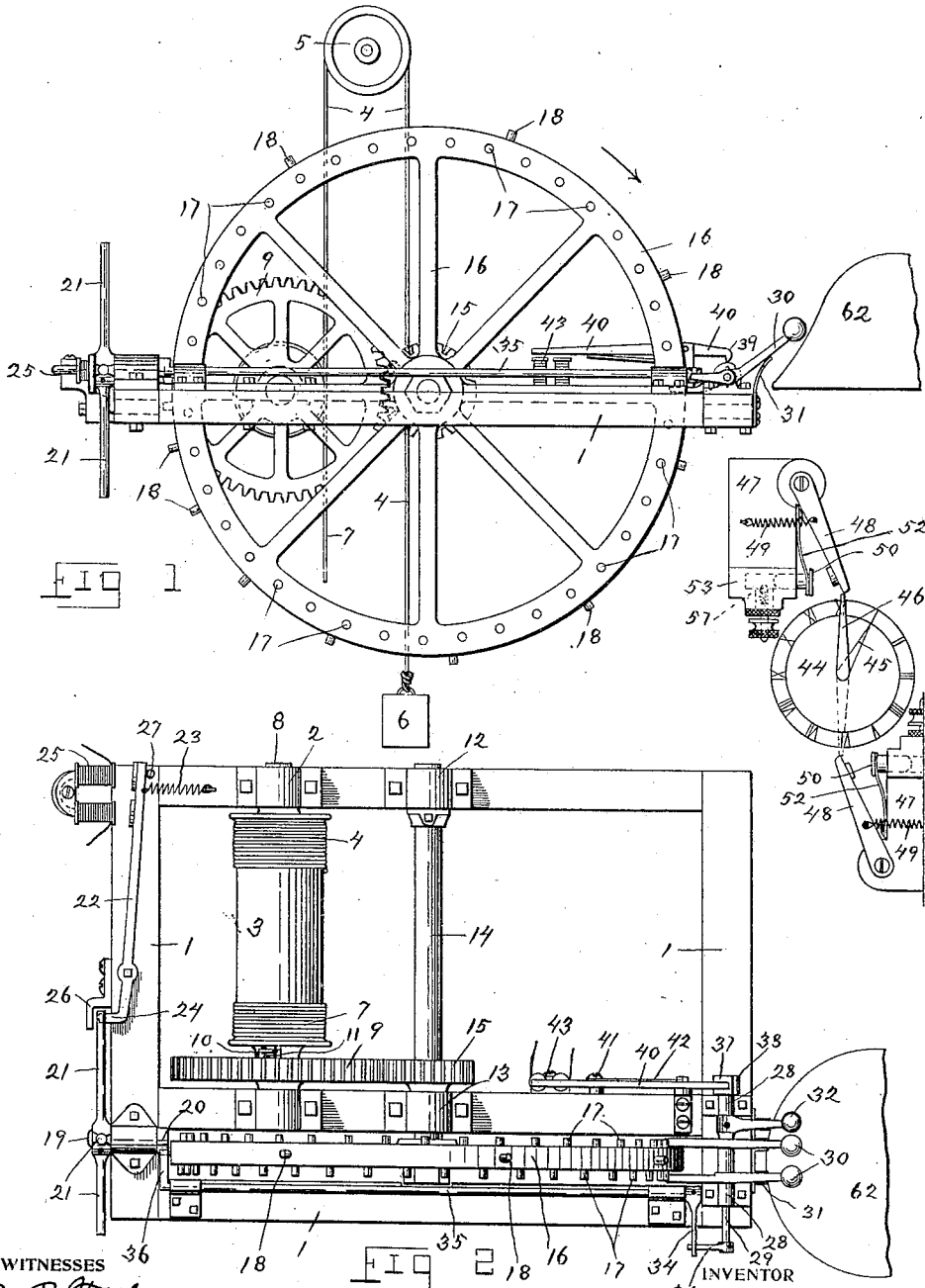

WITNESSES
B. P. Galtin
M. L. Lefevre

INVENTOR
BY *David F. Magee*

John Thompson
ATTORNEY

D. F. MAGEE.
 CLOCK CONTROLLED BELL STRIKING MECHANISM.
 APPLICATION FILED JUNE 24, 1910.

993,453.

Patented May 30, 1911.

2 SHEETS—SHEET 2.

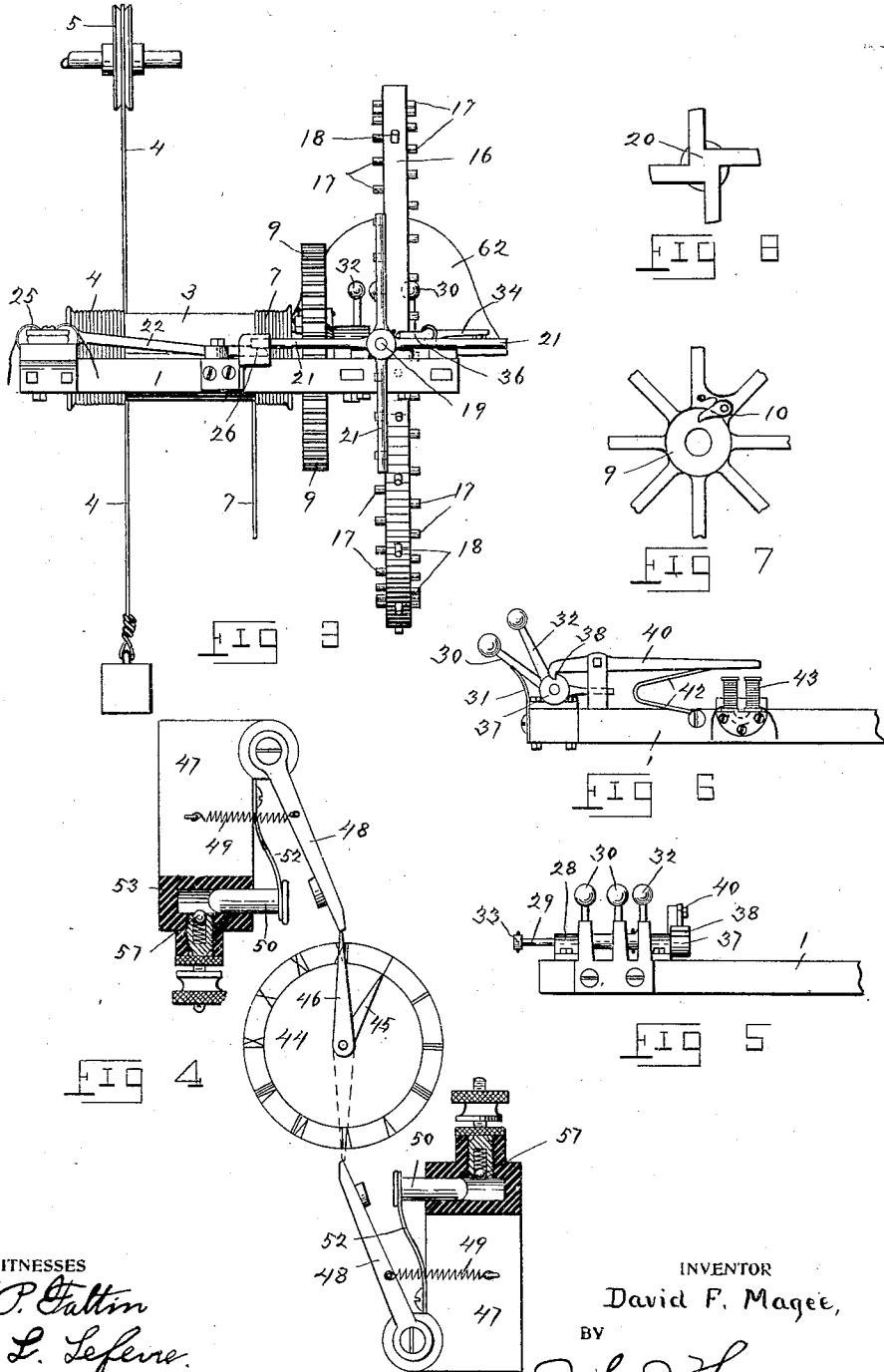

WITNESSES
B. P. Galtin
M. L. Lefevre.

INVENTOR
 David F. Magee,
 BY
John Thompson
 ATTORNEY

UNITED STATES PATENT OFFICE.

DAVID F. MAGEE, OF LANCASTER, PENNSYLVANIA.

CLOCK-CONTROLLED BELL-STRIKING MECHANISM.

993,453.

Specification of Letters Patent. Patented May 30, 1911.

Application filed June 24, 1910. Serial No. 568,608.

To all whom it may concern:

Be it known that I, DAVID F. MAGEE, a citizen of the United States, residing at Lancaster, in the county of Lancaster and State of Pennsylvania, have invented certain new and useful Improvements in Clock-Controlled Bell-Striking Mechanism, of which the following is a specification, reference being had therein to the accompanying drawing.

This invention relates to a bell-striking mechanism and more particularly to that class which is controlled and electrically operated by a clock actuated mechanism which may be situated at a distant point and connected to the striking mechanism by electric wires.

The objects of the invention are to provide a simple, durable and cheap mechanism, that may be mounted in adjacent relation to a bell of the usual type, such as used in churches, schools, etc.; the device being run by a cord and weight and so arranged as to be tripped at prearranged intervals by electric magnets which in turn are operated by a clock-work mechanism which may be situated at a distance from the striking mechanism in another building, if desired.

Another object of the invention is to provide a device of this class which shall be automatic in operation, striking both the hours and the half-hours, or any time as prearranged, and thus be adapted in schools for marking the periods.

With these and other objects in view my invention consists in certain construction and combination of parts as will hereinafter be fully described and claimed in the following specification and illustrated in the accompanying drawings, which form a part of this application and in which like figures of reference refer to corresponding parts in all of the views; but it is fully understood that while I have here described my invention as shown, that I do not confine myself to the exact design as shown, as slight changes may be made in the construction and arrangement of the several parts without departing from the spirit of the invention.

In the drawings:—Figure 1, is a side elevation of the bell-striking mechanism, and the controlling clock mechanism. Fig. 2, is a top plan view of the bell-striking mechanism. Fig. 3, is an end elevation of the

same. Fig. 4, is an enlarged detail view of the electrical switch operating clock mechanism. Fig. 5, is a partial detail end view of the striking hammers. Fig. 6, is a partial detail side view of the same. Fig. 7, is a partial detail view of the inner side of the hub of the spur gear showing the ratchet dog. Fig. 8, is a detail view of the escapement or trip star-wheel.

Referring to the drawings, 1, indicates a frame which is placed in an adjacent position to the bell 2. Upon said frame 1, in the bearings 2, is rotatably mounted a shaft 8, and upon said shaft is rotatably mounted a drum 3, upon one end of which is secured one end of an operating weight cord 4, which is wound thereon and carried over a pulley 5, and has attached to its free end the weight 6; while secured upon the other end of said drum 3, and wound thereon in an opposite direction to that of the cord 4, is the winding cord 7; and it may here be stated that as the cord 4, is unwound from the drum 3, the cord 7, is wound thereon and in this manner when the cord 7, is pulled downward the drum 3, is revolved and the cord 4, is wound thereon and the weight 6, raised. Mounted upon said shaft 8, and adjacent to one end of said drum 3, is rotatably mounted a spur gear 9; the inner face of the hub of which is supplied with a ratchet dog 10, which engages a ratchet 11, on the end of the drum 3, so that in winding up the weight cord 4, the drum 3, will freely revolve, but will not turn in the opposite direction without operating the spur gear 9.

Parallel to the shaft 8, and rotatably mounted in the bearings 12, and 13, secured upon the frame 1, is a main shaft 14, upon which, and in mesh with the spur gear 9, is secured a pinion 15; while upon the end of said shaft 14, is secured the timing wheel 16. Said timing wheel 16, is provided upon the opposite sides of its rim with the hammer pins 17, which are placed at equal distances apart, and the pins 17, upon one side of said rim are directly opposite the center of the space between the pins 17, upon the opposite side; while upon the face of said timing wheel 16, are placed the trip or escapement pins 18, which are so arranged that there is an increasing distance between each succeeding pin from one to twelve.

The escapement mechanism comprises a

short shaft 19, which stands at right angles to the axis of the timing wheel 16, and is journaled on the end of the frame 1; and upon the inner end of said shaft 19, is secured the star-wheel 20, the teeth of which engage the pins 18, on the face of the timing wheel 16; while upon the outer end of said shaft 19, is secured the star-wheel 21, the arms of which are engaged and its rotation controlled by a magnet lever 22, which is pivoted upon said frame 1, in such a manner that when held in a normal position by the spring 23, its hooked end 24, will engage one of the arms of the star-wheel 21, and prevent the same from turning; while if an electrical current is sent through the magnet 25, the lever 22, will be attracted thereto and the star-wheel 21, released for a quarter turn. The guard 26, serves to protect the end of the arm of the star-wheel 21, and the stop pin 27, limits the action of the lever 22. Upon the opposite end of the frame 1, and parallel with the axis of the wheel 16, is mounted in the bearings 28, a rocker-shaft 29, upon which is freely mounted a pair of bell hammers 30, for striking the hours, the rearward ends of which are engaged by the hammer pins 17, in such a manner that by the travel of said wheel 16, the hammers 30, are alternately raised and allowed to drop, striking the bell, and are instantly slightly raised from contact therewith by the springs 31.

For striking the half-hour I have provided a separate bell hammer 32, which is secured upon the rocker-shaft 29; while upon the outer end of said shaft 29, is secured an arm 33, which engages an arm 34, at right angles thereto which is secured upon a rocker-shaft 35, mounted upon the frame 1, at right angles to the axis of the timing wheel 16, and extending nearly the entire length of said frame, and having secured upon its other end an arm 36, for engagement with the star-wheel 20; while upon the opposite end of the rocker-shaft 29, from that upon which the arm 33, is placed, is secured a head 37, formed with a notch 38, for engagement by the hooked nose 39, of a magnet lever 40, which is pivoted upon the bracket 41, attached to the frame 1; and normally held in engagement with said notch 38, by the spring 42, and actuated by the magnet 43, as hereinafter described.

The clock actuated controlling mechanism for actuating the magnets at predetermined intervals, comprises a clock, having the face 44, the hour hand 45, and the minute hand 46, the end of which projects beyond the face of the clock.

Mounted upon a suitable frame or support, (not shown) adjacent to the clock, are the electric contact switches; one to be operated when the minute hand 46, is at twelve for operating the hour hammers 30, and the

other to be operated by the minute hand 46, when the same is at six for setting the half-hour hammer 32. Said switches comprise an insulating base 47, upon which is pivoted a striking hammer 48, which, when carried out by the minute hand 46, against the action of the spring 49, and released thereby strikes the plunger 50, and forces the same in the orifice in the insulation 53, to make an instantaneous contact with the terminal ball 57, attached to the positive conductor; the plunger 50, instantly being brought out of contact by the spring 52; which is also attached to the negative conductor.

The operation of the device as a whole is as follows:—The weight cord 4, having been wound upon the drum 3, by revolving said drum by the winding cord 7, as allowed by the ratchet 11, as the minute hand 46, of the clock approaches the hour, its point engages the end of the hammer 48, and carries it outward, releasing it upon the hour, allowing it to fly back, striking the plunger 50, and making an electrical contact, which in turn sends an instantaneous current through the magnet 25, which will attract the lever 22, and release the star-wheel 21, allowing it to make a quarter turn, and the timing wheel 16, to travel the distance between the pins 18; the pins 17, striking the hammer 30, causing them to strike the bell once for each pin 17; the number of strokes depending upon the number of pins 17, between two of the pins 18. For operating the half-hour hammer 32, each time that the star-wheel 20, makes a quarter turn the rocker-arm 35, is operated which, by the action of the arms 33, and 36, raises the half-hour hammer 32, and cocks it by the lever 40, engaging the notched head 37, of the shaft 29; and as the minute hand 46, approaches the half-hour the other switch is operated and the magnet 43, operates to attract the lever 40, and release the half-hour hammer 32, for one stroke. It will thus be seen that the clock and switches can be located at a distance from the striking mechanism.

Having thus described my invention what I claim as new and desire to secure by Letters Patent is:—

A clock governed bell-striking mechanism, comprising a frame, a main shaft and a parallel drum shaft journaled in said frame, a spur gear secured upon said drum shaft, a pinion secured upon said main shaft and driven by said spur gear, a drum rotatably mounted on said drum shaft, a ratchet and pawl for connecting said drum to said spur gear, a weight cord attached to said drum for revolving the same, a winding cord attached to said drum for revolving the same in an opposite direction, a timing wheel mounted upon said main shaft, hammer pins secured upon the sides of said wheel, a set of hammers mounted adjacent to said wheel

and adapted to be actuated by said pins, escapement pins secured to the face of said wheel, an escapement wheel mounted adjacent to said timing wheel and engaging said escapement pins, a trip-lever pivoted upon said frame and engaging said escapement wheel, an electric magnet mounted adjacent to said trip-lever for actuating the same, and

a clock controlled switch for actuating said magnet.

In testimony whereof I affix my signature in presence of two witnesses.

DAVID F. MAGEE.

Witnesses:

MABEL L. LEFEVRE,
JOHN J. THOMPSON.

10

Copies of this patent may be obtained for five cents each, by addressing the "Commissioner of Patents, Washington, D. C."
