

July 15, 1969

P. S. EVANS 3RD

3,455,059

VAULT OR MANHOLE COVER ASSEMBLY

Filed Feb. 1, 1968

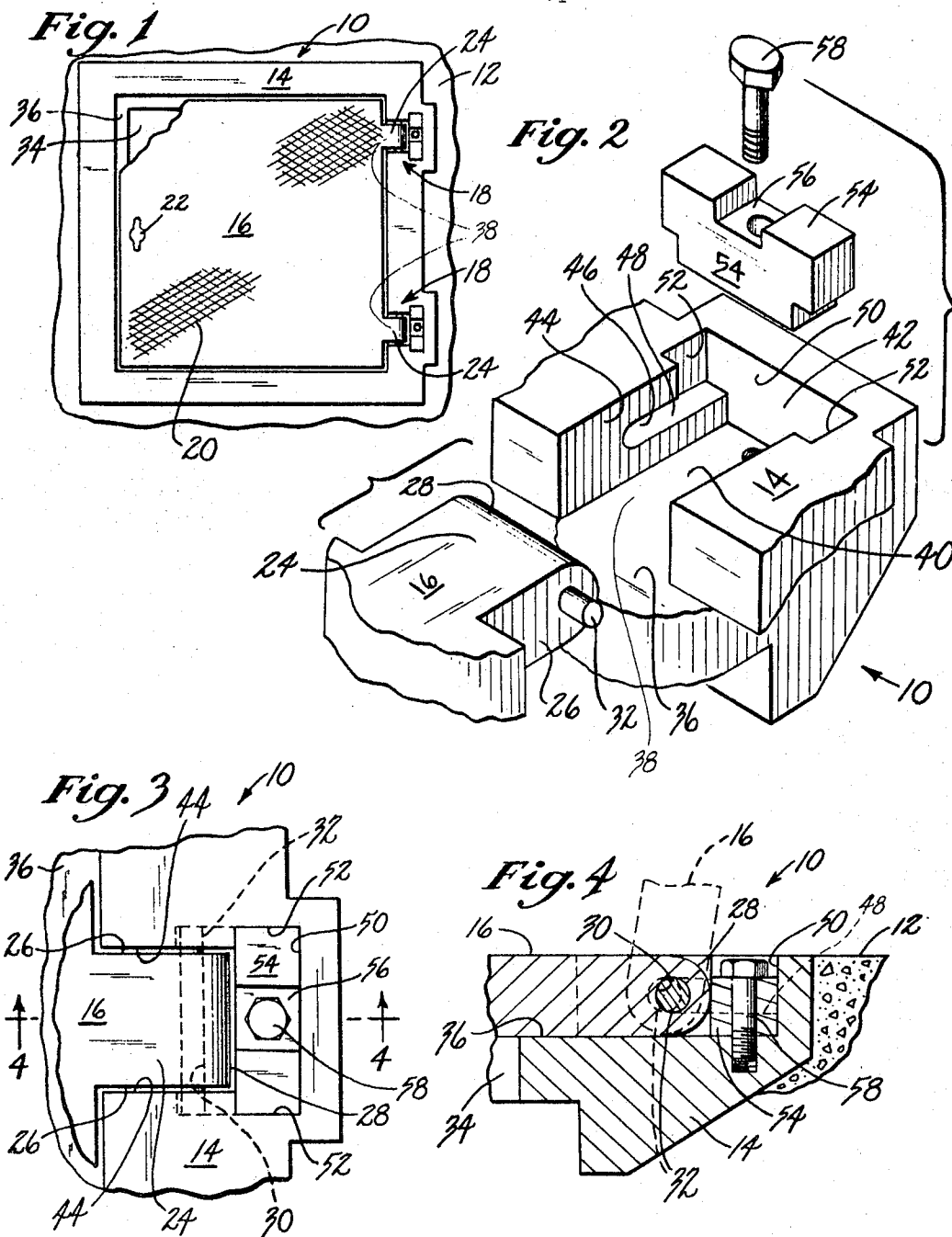

INVENTOR.

Philip S. Evans III

BY

*McCormick, Paulding & Huber*  
ATTORNEYS

1

2

3,455,059

**VAULT OR MANHOLE COVER ASSEMBLY**  
 Philip S. Evans 3rd, Woodbury, Conn., assignor to The  
 Waterbury Foundry Company, Waterbury, Conn., a  
 corporation of Connecticut

Filed Feb. 1, 1968, Ser. No. 702,225

Int. Cl. E04b 1/32

U.S. Cl. 49—397

11 Claims

## ABSTRACT OF THE DISCLOSURE

A vault or manhole cover assembly has a detachable cover secured to a supporting frame by separable hinge connections comprising tongues projecting from the cover and fulcrumed in recesses in the frame. Each tongue is releasably retained in an associated recess by a block secured in the recess and removable therefrom when the cover is in either its open or closed position.

### Background of invention

This invention relates in general to vault or manhole cover assemblies, and deals more particularly with an improved assembly of this type adapted to be embedded in pavement and including a cover detachably secured to a frame by separable hinge connections.

Cover assemblies of the afordescribed type embedded in pavement, as in a roadbed or the like, are generally adapted to bear heavy traffic, but are also subject to be damaged thereby. Removal of the cover and associated hinge part of such an assembly for repair or replacement is generally a troublesome and time-consuming operation.

Accordingly, it is the general aim of this invention to provide an improved durable cover assembly of the afordescribed type having a detachable cover secured to a frame by separable hinges and readily removable therefrom for convenience in the repair or replacement of assembly parts.

Other objects and advantages of the invention will be apparent from the following description and from the drawings forming a part thereof.

### Summary of invention

In accordance with the present invention a vault or manhole cover assembly is provided which includes a frame and a cover detachably hinged thereto. Hinged connection is provided by a tongue projecting from the cover and received in an associated recess in the frame. The tongue carries a removable pivot pin fulcrumed in the recess and retained therein by a block positioned in the recess after assembly of the cover with the frame. The block is immediately accessible for removal from the recess when the cover is in either its open or closed position.

### Brief description of the drawing

FIG. 1 is a plan view of a vault or manhole cover assembly embodying the present invention and embedded in pavement.

FIG. 2 is a somewhat enlarged exploded fragmentary perspective view of the cover assembly of FIG. 1.

FIG. 3 is a somewhat enlarged fragmentary plan view of the cover assembly of FIG. 1.

FIG. 4 is a sectional view taken generally along the line 4—4 of FIG. 3.

### Detailed description of the preferred embodiment

Turning now to the drawing a vault or manhole cover assembly embodying the invention, and indicated generally at 10, is shown embedded in pavement 12 and includes a base or frame 14 and a cover 16. The cover is detachably secured to the frame by separable hinge

connections indicated generally at 18, 18 and is pivotally moveable relative thereto between closed and open positions respectively indicated in full and broken lines in FIG. 4. The shape of both the cover and its supporting frame, the arrangement of the hinge connection therebetween, and the material from which these parts are made may vary. When the assembly is made with a round cover a single hinge connection may be provided. However, the illustrated cover assembly 10 has a generally square cover and frame preferably cast from iron or steel and joined by a pair of hinge connections.

The cover 16 comprises a plate of generally uniform thickness which has a pattern 20 cast or otherwise formed on its upper surface to impart a non-skid quality thereto. Preferably, a suitable locking means (not shown) is provided to retain the cover in its closed position and for this purpose a key hole 22 is provided near the forward or left marginal edge of the cover as it appears in FIG. 1. A pair of laterally spaced tongues 24, 24 integrally formed on the cover project rearwardly therefrom to form parts of the separable hinge connections 18, 18. Considering one of the tongues 24, 24 it will be noted that the tongue includes generally parallel sidewalls 26, 26 and a rounded free end portion 28 which has a radius of curvature substantially equal to one-half the thickness of the cover. A generally cylindrical bore 30 extends through the tongue 24 concentric with its rounded end portion 28 and receives a pivot pin 32 therethrough. The pin 32 is preferably loosely received in the bore 30 and has end portions which project laterally in opposite directions from the tongue. A durable nonferrous material such as bronze is preferably used to make the pin 32 so that it may be removed from its associated tongue with relative ease even after long exposure to the elements.

The frame 14 surrounds the cover, has an access opening 34 therethrough, and is provided with a seating surface 36 which surrounds the opening 34 and upon which the margin of the cover rests when the cover is in its closed position. Forwardly and upwardly opening recesses 38, 38 formed in the rear part of the frame 14 receive and retain the tongues 24, 24 and provide fulcrums for the pins 32, 32.

Considering now one of the recesses in further detail and referring particularly to FIG. 2, it will be seen that the illustrated recess 38 has a generally T-shaped horizontal cross section and includes a forward portion 40 and a laterally enlarged rear portion 42. The bottom wall of the recess 38 is formed by the rearward extension of the seating surface 36. Laterally spaced sidewalls 44, 44, adapted to receive an associated tongue 24 therebetween further define the forward portion 40 and the lower part of the rear portion 42. Each sidewall 44 has a rearwardly extending channel 46 therein which opens into the rear portion 42 and includes a generally horizontally disposed bottom wall 48 which extends into the rear portion 42 for a purpose hereinafter evident. The rear portion has a generally T-shaped vertical cross section, a forwardly facing rear wall 50, and upper side wall portions 52, 52 which extend upwardly from the walls 48, 48. The side wall portions 52, 52 are laterally spaced apart a distance at least equal the lateral dimension of the pin 32.

Assembly of the cover 16 with the frame 14 is effected by inserting each tongue 24 and its associated pin 32 in a recess 38. The projecting ends of the pin 32 engage the bottom walls 48, 48 which serve to guide said end portions into the channels 46, 46 as the tongue 24 is moved forwardly in the recess 38. After each tongue 24 has been positioned in an associated forward portion 40, 40 the cover 16 is preferably moved to its closed position and a block 54 positioned in each rear portion to retain the cover 16 in assembly with the frame 14.

Each block 54 has a generally T-shaped vertical cross

3

section, as best shown in FIG. 2, and complements the associated recess rear portion 42. Thus, each rear portion 42, is substantially filled by its associated block 54 so that sand or other foreign matter which might be detrimental to cover movement cannot enter. An upwardly opening recess 56 in the block 54 receives the head of a cap screw 58 which passes through the block and threadably engages the frame 14 to releasably retain the block in assembly therewith. It will be evident that the cap screw 58 and the block 54 are immediately accessible and may be removed when the cover 16 is in either its open or closed position. The pin 32, the channels 46, 46 and the block 54 are arranged to cooperate with the cover 12 so that in its open position the cover is inclined rearwardly from its pivot axis, as indicated in broken lines in FIG. 4, in which position it tends to remain until it is pivoted toward its closed position. The cover 16 cooperates with the frame 14 and with the blocks 54, 54 in the closed position to provide a substantially flat upwardly facing surface in the plane of the pavement 12.

The drawing shows a preferred embodiment of the invention and such embodiment has been described, but it will be understood that various changes may be made from the construction disclosed and that the drawing and description are not to be construed as defining or limiting the scope of the invention, the claims forming a part of this specification being relied upon for that purpose.

I claim:

1. A vault or manhole cover assembly comprising a cover having a rearwardly projecting tongue, pin means laterally projecting in opposite directions from said tongue, and a base supporting said cover for pivotal movement between open and closed positions and having a forwardly and upwardly opening recess therein, said recess including a forward portion into which said tongue extends when said cover is in a closed position and a rear portion, said forward portion including laterally spaced side walls receiving said tongue therebetween, said side walls defining opposing generally rearwardly extending channels opening to said rear portion, said channels receiving and retaining said pin means and providing a fulcrum therefor, said rear portion including opposing side walls laterally spaced apart a distance at least equal to the lateral dimension of said pin means to permit insertion of said tongue and its associated pin means therein whereby said pin means are received in said channels, and means for retaining said pin means in said channels.

2. A vault or manhole cover assembly as set forth in claim 1 wherein said rear portion is partially defined by rearward extensions of the bottom walls of said channels.

4

3. A vault or manhole cover assembly as set forth in claim 1 further characterized by said tongue having a laterally extending bore therethrough, said pin means comprising an elongated pin received in said bore and extending therethrough.

4. A vault or manhole cover assembly as set forth in claim 3 wherein said tongue is made from a ferrous material and said pin is made from a nonferrous material.

5. A vault or manhole cover assembly as set forth in claim 1 further characterized by said recess having a generally T-shaped horizontal cross section.

6. A vault or manhole cover assembly as set forth in claim 1 wherein said means for retaining said pin means comprises a block received in said rear position.

7. A vault or manhole cover assembly as set forth in claim 6 further characterized by said recess having a generally T-shaped horizontal cross section, said rear portion having a substantially T-shaped vertical cross section.

8. A vault or manhole cover assembly as set forth in claim 6 wherein said base is a frame having an opening therethrough and including a seating surface supporting an associated marginal portion of said cover in its closed position, said frame generally surrounding the peripheral edge of said cover in its closed position and cooperating therewith and with said block to provide a substantially flat upwardly facing surface.

9. A vault or manhole cover assembly as set forth in claim 6 including means for releasably retaining said block in said rear portion.

10. A vault or manhole cover assembly as set forth in claim 9 wherein said means for releasably retaining said block comprises a fastener accessible from above said recess in all positions of said cover.

11. A vault or manhole cover assembly as set forth in claim 10 wherein said fastener is a single screw passing through said block and threadably engaging said base.

#### References Cited

##### UNITED STATES PATENTS

1,105,826	8/1914	Norton	94—36
1,576,614	3/1926	Knell	49—397
2,365,378	12/1944	Benson	16—128 XR
3,130,651	4/1964	Werner	94—36

KENNETH DOWNEY, Primary Examiner

U. S. CI. X.R.

16—171, 174; 94—36; 52—20; 49—402