

**(12) PATENT**  
**(19) AUSTRALIAN PATENT OFFICE**

**(11) Application No. AU 200065660 B2**  
**(10) Patent No. 779472**

(54) Title  
**In vitro repair of bone and/or cartilage defects**

(51)<sup>7</sup> International Patent Classification(s)  
**A61F 002/30                      A61K 038/39**  
**A61F 002/28                      A61L 027/24**  
**A61K 038/18                      A61L 027/54**

(21) Application No: **200065660**

(22) Application Date: **2000.07.25**

(87) WIPO No: **WO01/06949**

(30) Priority Data

(31) Number	(32) Date	(33) Country
<b>9902807</b>	<b>1999.07.28</b>	<b>SE</b>
<b>9902808</b>	<b>1999.07.28</b>	<b>SE</b>

(43) Publication Date : **2001.02.13**

(43) Publication Journal Date : **2001.04.26**

(44) Accepted Journal Date : **2005.01.27**

(71) Applicant(s)  
**Interface Biotech A/S**

(72) Inventor(s)  
**Kurt Osther; Peter Storgaard**

(74) Agent/Attorney  
**F B Rice and Co,605 Darling Street,BALMAIN NSW 2041**

(56) Related Art  
**WO 1996/024310**  
**WO 1998/030234**

(19) World Intellectual Property Organization  
International Bureau



(43) International Publication Date  
1 February 2001 (01.02.2001)

PCT

(10) International Publication Number  
**WO 01/06949 A2**

- (51) International Patent Classification<sup>7</sup>: **A61F**
- (21) International Application Number: **PCT/EP00/07111**
- (22) International Filing Date: **25 July 2000 (25.07.2000)**
- (25) Filing Language: **English**
- (26) Publication Language: **English**
- (30) Priority Data:  
9902807-8 28 July 1999 (28.07.1999) SE  
9902808-6 28 July 1999 (28.07.1999) SE
- (71) Applicant (for all designated States except US): **INTERFACE BIOTECH A/S [DK/DK]; c/o KAS Glostrup EB4, Nordre Ringvej 59, DK-2600 Glostrup (DK).**
- (72) Inventors; and  
(75) Inventors/Applicants (for US only): **OSTHER, Kurt [DK/US]; 10715 North 117th Way, Scottsdale, AZ 85259 (US). STORGAARD, Peter [DK/DK]; Vestervang 6A, DK-2500 Valby (DK).**
- (74) Agent: **ÅKERNAM, Mårten, L.; C/O Albihns Patentbyrå Malmö AB, P.O. Box 4289, S-203 14 Malmö (SE).**
- (81) Designated States (national): **AE, AG, AL, AM, AT, AU, AZ, BA, BB, BG, BR, BY, BZ, CA, CH, CN, CR, CU, CZ, DE, DK, DM, DZ, EE, ES, FI, GB, GD, GE, GH, GM, HR, HU, ID, IL, IN, IS, JP, KE, KG, KP, KR, KZ, LC, LK, LR, LS, LT, LU, LV, MA, MD, MG, MK, MN, MW, MX, MZ, NO, NZ, PL, PT, RO, RU, SD, SE, SG, SI, SK, SL, TJ, TM, TR, TT, TZ, UA, UG, US, UZ, VN, YU, ZA, ZW.**
- (84) Designated States (regional): **ARIPO patent (GH, GM, KE, LS, MW, MZ, SD, SL, SZ, TZ, UG, ZW), Eurasian patent (AM, AZ, BY, KG, KZ, MD, RU, TJ, TM), European patent (AT, BE, CH, CY, DE, DK, ES, FI, FR, GB, GR, IE, IT, LU, MC, NL, PT, SE), OAPI patent (BF, BJ, CF, CG, CI, CM, GA, GN, GW, ML, MR, NE, SN, TD, TG).**
- Published:**  
Without international search report and to be republished upon receipt of that report.
- For two-letter codes and other abbreviations, refer to the "Guidance Notes on Codes and Abbreviations" appearing at the beginning of each regular issue of the PCT Gazette.

(54) Title: ***IN VITRO* REPAIR OF BONE AND/OR CARTILAGE DEFECTS**

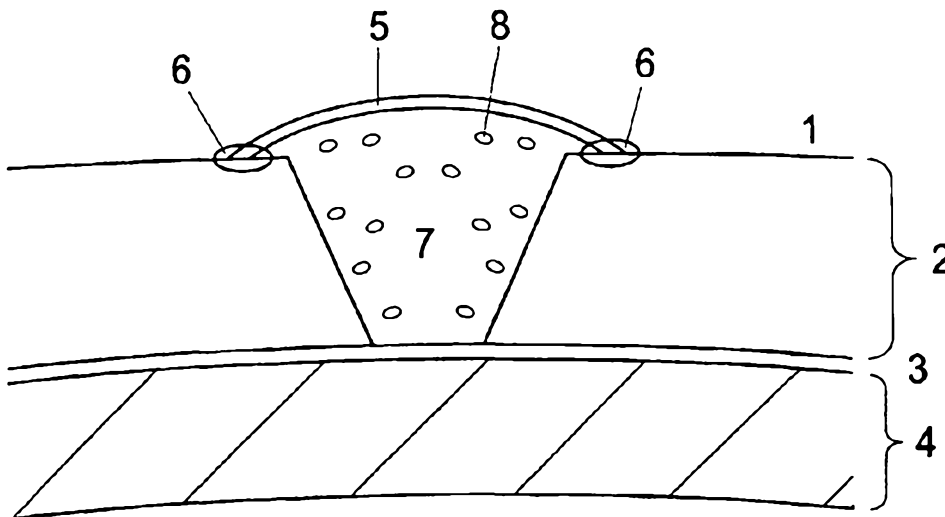

(57) Abstract: The present invention relates to methods and materials for in vivo repair of cartilage or bone and cartilage defects in mammals. The invention relates to membranes carrying a composition comprising at least one stimulation molecule, which is capable of inducing signal transduction in chondroblasts/chondrocytes and/or osteoblasts/osteocytes. Furthermore the invention relates to a method for the preparation of chondroblasts/chondrocytes and/or osteoblasts/osteocytes suspensions.



**WO 01/06949 A2**

## *IN VITRO* REPAIR OF BONE AND/OR CARTILAGE DEFECTS

### Field of invention

The present invention relates to method and materials for in vivo repair of  
5 cartilage defects or bone and cartilage defects in joints in mammals, such as human  
and horses.

### Background of invention

More than one million human arthroscopic procedures and total joint re-  
10 placements are performed each year in the U.S. and Europe together. Included in  
these numbers are in the U.S., about 90,000 total knee replacements, and around  
50,000 procedures for repairing defects in the knee alone per year (In: Praemer, A.,  
Furner, S., Rice, D.P., Musculoskeletal Conditions in the United States, Park Ridge,  
Ill.: American Academy of Orthopaedic Surgeons, 1992, 125).

15 Among different breeds of horses in U.S. and in Europe there are around five  
million registered "expensive" Thoroughbred Racehorses used in horse races,  
whereof an estimated 60% is directly or indirectly owned by U.S. horse-owners. Of  
all breeds Thoroughbreds is the most frequent sufferer of degenerative joint disease,  
mostly in the form of osteochondritis dissecans (OCD). The most often joint  
20 affected is the so-called stifle joint (femoropatellar joint, hind leg). The most  
common age for horses and especially racehorses to develop OCD is between 1 and  
6 years old. The earlier, the training of thoroughbreds is started (1 year old or less)  
the more frequent the disorder will appear.

In general surgery including arthroscopic intervention is used in most of the  
25 cases with clinical symptoms. Around 64% of the horses treated return to their  
previous use (racing, etc.). Approximately 35 % of the horses cannot return to their  
previous use within racing or with less possibilities of obtaining previous levels of  
racing.

A second condition that can be observed, described as OCD is fragmentation  
30 at the back of the fetlock off the proximal or plantar aspect of the first phalanx or  
long pastern bone. A third, often trauma related condition of racehorses is cartilage  
damage to the cannon bone condyles, which actually is not a true OCD. OCD in  
shoulder joints often affects large areas of the joint surface and secondary osteo-  
arthritis is common.

35 Conservative or medicinal treatment has only a limited effect and is mainly  
targeted at keeping the horse free from pains. The drugs are typically non-steroidal  
anti-inflammatory drugs (NSAID). Surgery of the shoulder is difficult due to the  
depth of the joint below the muscles in the area.

**CONFIRMATION COPY**

The effect on equine articular cartilage repair in joints medicated with polysulfated glycosaminoglycan (PSGAG) or sodium hyaluronate (SH) has been tested at Ohio State University, College of Veterinary Medicine, Columbus, Ohio. Results of this study indicated that no beneficial effect on clinical parameters, the  
5 gross appearance, or the microscopic appearance of defects when compared to saline controls. Some evidence from this study suggests that intraarticular PSGAG may have a detrimental effect on the healing of articular cartilage.

Occurrence of subchondral cystic lesions, also called bone cysts or osseous cyst-like lesions is commonly recognised abnormalities of bones and joints that may  
10 or may not cause lameness. The most troublesome cysts are articular cysts. Controversy exists as to whether these lesions are a manifestation osteochondritis secondary to a joint trauma, or a combination of stress and trauma.

Human articular cartilage is incapable of undergoing self-repair since chondrocytes lose their mitotic ability during the first year of life. Defects in  
15 articular cartilage, especially in weight-bearing joints, will predictably deteriorate toward osteoarthritis. No conventional method may prevent this deterioration.

Drilling of the subchondral bone can lead to fibrocartilage formation, which is non-resilient and can only be considered a temporary repair that slowly degrades. Animal studies have indicated that introducing proliferating chondrocytes such as  
20 articular chondrocytes may reliably reconstruct joint defects (Robinson D., et al., *Isr. Med. Assoc.J.*, 2000, 2:290).

Autologous chondrocyte implantation (ACI) has proven clinically effective in restoring hyaline-like cartilage to isolated pathological full thickness chondral lesions of the human knee. Several authors have performed chondrocyte implan-  
25 tation in humans with excellent results (Brittberg et al., 1994 *New Engl. J. Med.*; Minas, T., *Am. J. Orthop.* 1998, 11:739).

A method for regeneration treatment of cartilage would be an advantage and could be performed at an earlier stage of a joint damage reducing the number of humans needing artificial joint replacement surgery. Previously, cleaning or resur-  
30 facing the cartilage structure have been attempted using subchondral drilling, abrasion, etc. whereby diseased cartilage and even subchondral bone is excised (Insall, J., *Clin. Orthop.* 1974, 101:61; Ficat, R.P., et al., *Clin Orthop.* 1979, 144:74; Johnson, L.L., In: (McGinty, J.B., Ed.) *Operative Arthroscopy*, New York, Raven Press, 1991, 341).

35 Other methods such as suturing a periosteal flap (for instance removed from tibia) over the defect has been used either as a treatment procedure in itself, or has been used in combination with implantation of cultured (e.g., autologous) chondrocytes. The methods using this combination have in principal been developed by Brittberg et al., (Brittberg, M., et al., *New Engl. J. Med.*, 1994, 331:889).

Cells cultured using the methods described by Brittberg et al., Engl. J. Med., 1994, 331:889 are used for autologous implantation into knee joints of patients. Kurt Osther et al. have described in U.S. patent No. 5,759,190, the use of a barrier towards bone that may be useable in osteoarthritis type of lesions in theory, in order to prevent  
 5 bleeding and proliferation of stem cells from the underlying denuded cancellous bone. The barrier is made of collagen type I.

The major role in the success of an autologous chondrocyte implantation is profoundly dependent on the condition of the chondrocytes to be implanted. It is of major importance that the chondrocyte culture is viable and inducible for both  
 10 proliferation and when implanted capable of providing a sufficient matrix production (Mayhew, T.A., Tissue Engl. 1998, 4:325). It is important that the chondrocytes to be implanted are cultured under the most gentle and strictest culture methods avoiding unnecessary enzymatic damage of the cell membrane, and at the same time obtaining the most optimal chondrocyte culture as possible to produce a healthy hyaline articular  
 15 cartilage. The use of cell culturing method, most gentle to the chondrocyte is of utmost importance in order to obtain a sufficiently healthy implant cartilage, capable of interacting with the surrounding cartilage *in situ*. Even equally important is to create an optimal cartilage structure as part of the repair of osteoarthritic defects.

The invention provides improved membranes to be used for the treatment of  
 20 cartilage or cartilage and bone defects in mammals. The invention further provides improved methods for the preparation of chondroblasts/chondrocytes and osteoblast/osteocytes to be used for the treatment of cartilage or bone and cartilage defects in mammals. The invention also provide new methods for the treatment of cartilage or bone and cartilage defects in mammals.

Any discussion of documents, acts, materials, devices, articles or the like which  
 25 has been included in the present specification is solely for the purpose of providing a context for the present invention. It is not to be taken as an admission that any or all of these matters form part of the prior art base or were common general knowledge in the field relevant to the present invention as it existed before the priority date of each claim  
 30 of this application.

#### Summary of the Invention

Throughout this specification the word "comprise", or variations such as "comprises" or "comprising", will be understood to imply the inclusion of a stated  
 35 element, integer or step, or group of elements, integers or steps, but not the exclusion of any other element, integer or step, or group of elements, integers or steps.

This application discloses method and material for *in vivo* repair of cartilage defects and bone and cartilage defects in joints in mammals, such as human and horses.

Accordingly, in a first aspect the invention relates to a cartilage membrane having at least one surface part carrying a composition comprising at least one  
5 stimulation molecule which is capable of inducing a signal transduction in chondroblasts/chondrocytes resulting in the chondroblasts/chondrocytes producing and secreting matrix components which form hyalin cartilage or more specifically hyaline articular cartilage.

In another aspect the invention relates to an interface membrane with a first  
10 surface part and a second surface part both carrying a composition comprising at

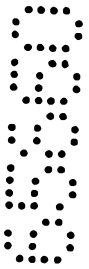

least one stimulation molecule which is capable of inducing a signal transduction in chondroblasts/chondrocytes and osteoblasts/osteocytes.

In yet another aspect the invention relates to a method for in vivo repair of cartilage defects in joints in mammals, comprising applying, over a cartilage free cavity of a joint, a cartilage membrane with a first surface part of which facing the  
5 cavity of a joint, the first surface part of the cartilage membrane carrying a composition comprising at least one stimulation molecule which is capable of inducing a signal transduction in chondroblasts/chondrocytes, introducing, in the cartilage free cavity between the cartilage membrane, the cartilage and the interface,  
10 a chondroblast/chondrocyte suspension, and;  
joining a portion part of the first surface part of the cartilage membrane to the surrounding articular surface so as to sealingly entrap the chondroblast/chondrocyte suspension in the cartilage free cavity using a sealing portion, thereby allowing the chondroblast/chondrocyte suspension to produce and secrete matrix components  
15 characteristic for hyalin.

Additionally, the invention relates to a method for in vivo repair of bone and cartilage defects in joints in mammals, such as in osteoarthritic joints, comprising applying, over a bone free cavity and under a cartilage free cavity of a joint, an interface membrane with a first surface part facing the bone free cavity, the inter-  
20 face membrane first surface part carrying a composition comprising at least one stimulation molecule which is capable of inducing a signal transduction in osteoblast/osteocyte, and the second surface part carrying a composition comprising at least one stimulation molecule which is capable of inducing a signal transduction in chondroblasts/chondrocytes,  
25 introducing, in the interstice between the interface membrane first surface part and the bone, an osteoblast/osteocyte suspension,  
joining a portion part of the first surface part of the interface membrane to the surrounding interface surface so as to sealingly entrap the osteoblast/osteocyte suspension in the bone free cavity using a sealing portion, thereby allowing the  
30 osteoblast/osteocyte suspension to produce and secrete matrix components characteristic for bone tissue;  
applying, over the cartilage free cavity, a cartilage membrane with a first surface part facing the second surface part of the interface membrane, the first surface part of the cartilage membrane carries a composition comprising at least one stimulation  
35 molecule which is capable of inducing a signal transduction in chondroblasts/chondrocytes resulting in the chondroblasts/chondrocytes producing and secreting matrix components which form hyalin cartilage,  
introducing, in the cartilage free cavity between the interface membrane, the cartilage membrane and the cartilage, a chondroblast/chondrocyte suspension,

joining a portion part of the cartilage membrane to the surrounding articular surface so as to sealingly entrap the chondroblast/chondrocyte suspension in the cartilage free cavity, thereby allowing the chondroblast/chondrocyte suspension to produce and secrete matrix components which form hyalin.

- 5 Furthermore the invention relates to a method for in vivo repair of bone and cartilage defects in joints in mammals using arthroscopy, such as in osteoarthritic joints, comprising treating an interface membrane with a first sealing portion component, applying, over a bone free cavity and under a cartilage free cavity of a joint, an interface membrane with a first surface part facing the bone free cavity, the  
10 interface membrane first surface part carrying a composition comprising at least one stimulation molecule which is capable of inducing a signal transduction in osteoblast/osteocyte, and the second surface part, which carries a composition comprising at least one stimulation molecule which is capable of inducing a signal transduction in chondroblasts/chondrocytes,  
15 introducing, in the interstice between the interface membrane first surface part and the bone, an osteoblast/osteocyte suspension, joining a portion part of the first surface part of the interface membrane to the surrounding interface surface so as to sealingly entrap the osteoblast/osteocyte suspension in the bone free cavity using a second sealing portion component,  
20 thereby allowing the osteoblast/osteocyte suspension to produce and secrete components characteristic for bone tissue; introducing, in the cartilage free cavity between the interface membrane, and the articular surface, a chondroblast/chondrocyte suspension, thereby allowing the chondroblast/chondrocyte suspension to produce and secrete components  
25 characteristic for hyalin.

- Additionally the invention relates to a method for preparation of chondroblast/chondrocyte or osteocyte/osteoblast suspensions comprising harvesting mesenchymal and/ or mesenchymal precursor cells from a source such as bone marrow, perichondrium, periosteum, blood, blood vessels or muscle; adding the  
30 harvested cells to a cell culture flask comprising at least one growth medium; growing the harvested cells until colony forming units with a cell number size in the ranging order of 10-20.000 cells /clone are formed with fibroblastic phenotype (CFU-f); transferring the CFU-f cells into a new cell culture flask comprising at least one selection medium for differentiation of the CFU-f's into chondro-  
35 blasts/chondrocytes, osteocytes/osteoblasts or myoblasts/myotubes; and harvesting of the differentiated cells.

### Brief description of the drawings

The present invention is further illustrated with reference to the drawings, wherein

Figure 1 shows one embodiment of the present invention applicable for treatment of cartilage defects. The figure shows the anatomy of normal cartilage and a cartilage defect.

Figure 2 shows another embodiment of the present invention applicable for the treatment of cartilage and bone defects. The figure shows the anatomy of normal cartilage and bone and defects of the cartilage and the bone.

### Detailed description of the invention

The invention relates to a method and materials for in vivo repair of cartilage or bone and cartilage defects in joints in mammals, such as human and horses. The chondroblast/chondrocytes cells and the osteoblast/osteocytes cells used in present invention are cells obtained from a mammal, such as human, horse, pig or calves, preferably autologous cells.

In the present invention, amino acid names are used as defined by the Protein DataBank (PDB) which is based on the IUPAC nomenclature ( IUPAC Nomenclature and Symbolism or Amino Acids and Peptides (residue names), Eur. J. Biochem., 138, 9-37 (1984) together with the corrections in Eur. J. Biochem., 152, 1 (1985). The term "amino acid residue " is intended to indicate an amino acid residue contained in the group of arginine (Arg or R), glycine(Gly or G), aspartic acid (Asp or D), proline(Pro or P), histidine (His or H), serine (Ser or S) and asparagine(Asn or N).

### Definitions

The term "chondroblast/chondrocyte suspension" is intended to mean a suspension containing progenitor cells to chondroblasts/chondrocytes or chondroblasts/chondrocytes, which after application to a defect stimulates by a stimulation molecule as defined hereinafter to differentiate and adhere, resulting in the production and secretion of matrix components characteristic for cartilage tissue. Matrix components such as fibrils of type II collagen, and sulfated proteoglycans, chondroitin-6-sulfate and keratan sulfate for the production of hyalin or hyalin articular cartilage.

The term "osteoblast/osteocyte suspension" is intended to mean a suspension containing progenitor cells to osteoblast/osteocyte or osteoblast/osteocyte which after application to a defect stimulates by a stimulation molecule as defined hereinafter to differentiate and adhere, resulting in the production and secretion of components characteristic for bone tissue.

The term "cartilage membrane" is intended to mean a membrane with the ability to bind chondroblasts/chondrocytes to at least one surface part of the membrane. Preferably, the cartilage membrane is capable of binding a stimulation molecule as defined hereinafter and optionally of a structure allowing the chondroblasts/chondrocytes in the chondroblast/chondrocyte suspension to adhere and invade the entire membrane, but not to pass through the membrane. Examples of suitable membranes are collagen I/III membranes purchased from Geistlich Biomaterials, Wollhusen, Switzerland or from Baxter, Denmark.

The term "interface membrane" is intended to mean a membrane with an ability to bind osteoblasts/osteocytes to a first surface part of the interface membrane and chondroblasts/chondrocytes to the second surface part of the interface membrane. Preferably, the interface membrane is capable of binding a stimulation molecule as defined hereinafter to both the first and the second surface part of the interface membrane. Optionally, the interface membrane has a structure allowing an osteoblast/osteocyte suspension to adhere and invade the first surface part of the interface membrane, but not pass through the interface membrane. Furthermore the interface membrane has a structure allowing a chondroblast/chondrocyte suspension to adhere and invade the second surface part of the interface membrane, but not to pass through the membrane. Examples of suitable membranes are collagen I/III membranes purchased from Geistlich Biomaterials, Wollhusen, Switzerland or from Baxter, Denmark.

The term "stimulation molecule" is intended to mean a peptide and/or protein or a fusion thereof, natural or synthetic or a mixture thereof, capable of inducing a signal transduction in chondroblasts/chondrocytes and osteoblasts/osteocytes. Preferably the stimulation molecule, comprising at least the amino acid residues, Arg-Gly-Asp, also named RGD motif. It will be understood that any motif or amino acid residue sequence, which has the same or substantially the same induction capability as a stimulation molecule comprising a RGD motif could also be used according to the invention.

The term "sealing portion" is intended to mean a glue capable to bind or seal the membrane and a surface located outside a defect cartilage and/or defect bone area and entrap a chondroblast/chondrocyte and/or a osteoblast/osteocyte suspension into a cartilage free cavity and/or bone free cavity.

The term "growth medium" is intended to mean a growth medium responsible for transferring the mesenchymal stem cells and /or mesenchymal precursor cells obtained from a mammal into colony forming units with fibroblastic phenotype (CFU-f).

The term "selection medium" is intended to mean a selection medium responsible for transferring the CFU-f into more defined cells such as chondroblasts/chondrocytes, osteoblasts/osteocytes or myoblasts/myocubes.

#### 5 Cartilage membrane carrying a stimulation molecule

In one aspect, the invention relates to a cartilage membrane carrying a stimulation molecule for use in treatments of cartilage defects in mammals, such as such as chondral lesions or osteochondral lesions, osteochondritis dissecans (OCD), chondromalacia and osteoarthritis. Example of such a cartilage membrane is shown in figure 1 reference 5 and 2 reference 50, respectively. However, the embodiments of the membranes found in figure 1 and 2 are examples of membranes and the invention should not be limited thereto.

The invention relates to a cartilage membrane, having at least one surface part, carrying a composition comprising at least one stimulation molecule, which is capable of inducing a signal transduction in chondroblasts/chondrocytes. Preferably, the cartilage membrane is a non-immunogenic, non-toxic, biodegradable membrane, more preferably, the cartilage membrane is porous or substantially porous, even more preferably, the cartilage membrane has a structure allowing chondroblasts/chondrocytes in a chondroblast/chondrocyte suspension to adhere and invade the entire membrane and most preferably the cartilage membrane is a natural collagen type I and/or III membrane or a synthetic membrane or part thereof. Example of a cartilage membrane is a periosteal flap excised from the patient's bone such as for instance proximal part of the tibia.

The cartilage membrane may be impregnated with the stimulation molecule prior to or directly after application of the membrane to a surface to be treated, such as the cartilage free cavity found in figure 1, reference 7. Preferably the cartilage membrane is impregnated using conventional techniques, such as spraying, painting or immersion or any other conventional technique.

In a preferred embodiment, the stimulation molecule comprises at least one RGD motif. Preferably, the stimulation molecule is a natural or synthetic protein or peptide or a fusion or a mixture thereof, more preferably the stimulation molecule is selected from the group consisting of collagen proteins such as collagen types II, VI, IX, and XI, proteoglycans such as aggrecans, decorin, fibromodulin and biglycan, and non collagenous proteins such as cryoprecipitate, fibronectin, vitronectin, fibronogen, fibrillin, kistrin, echistatin, von Willebrand factor, tenascin and anchorin CII, and even more preferably, the stimulation molecule is selected from the group consisting of collagen type II and fibronectin. Additionally, the stimulation molecule is attached to a support.

The final concentration of the stimulation molecule is not critical and is dependent on the degree of the cartilage defect to be treated. The stimulation molecule may be added to a final concentration within the range of nM to mM, preferably between, 1nM to 100 mM and more preferably 10mM.

5 In another embodiment of the invention the above described cartilage membrane is used for the preparation of a kit containing a cartilage membrane alone or in combination with at least one interface membrane as defined hereinafter for the treatment of cartilage defects or bone and cartilage defects. Furthermore, the kit may comprise other components useful for the treatment of cartilage or bone and  
10 cartilage defects in mammals, such as chondral lesions or osteochondral lesions, osteochondritis dissecans (OCD), chondromalacia and osteoarthritis.

#### Interface membrane carrying a stimulation molecule

In another embodiment, the invention relates to an interface membrane as  
15 defined above carrying a stimulation molecule for the treatment of a mammal having a cartilage and bone defect, such as chondral lesions or osteochondral lesions, osteochondritis dissecans (OCD), chondromalacia and osteoarthritis. Example of such an interface membrane is shown in figure 2, reference 21. However, the embodiment of the membrane 21 found in figure 2 is only an example  
20 and the invention should not be limited thereto.

The invention relates to an interface membrane with at least two different surface parts, a first and a second surface part, carrying at least one stimulation molecule capable of inducing a signal transduction in chondroblasts/chondrocytes and osteoblasts/osteocytes. The first surface part of the interface membrane has the  
25 ability to bind osteoblasts/osteocytes, for example figure 2, reference 22 and the second surface part of the interface membrane has the ability to bind chondroblasts/chondrocytes, for example figure 2, reference 26. Preferably, the interface membrane is a non-immunogenic, non-toxic, biodegradable membrane, more preferably the interface membrane is porous or substantially porous even more  
30 preferably the interface membrane has a structure allowing the chondroblasts/chondrocytes in the chondroblast/chondrocyte suspension to adhere and invade one side of the the interface membrane, but not to pass through the interface membrane and osteoblasts/osteocytes in the osteoblast/osteocyte suspension to the other side of the interface membrane but not to pass through the interface membrane  
35 and even more preferably the interface membrane is a natural or synthetic collagen type I and/or III membrane or part thereof. Example of an interface membrane is a periosteal flap excised from the patient's bone such as for instance proximal part of the tibia.

The interface membrane may be impregnated with the stimulation molecule prior to or after application of the interface membrane to a surface to be treated, such as for example the bone free cavity found in figure 2, reference 23. Preferably the interface membrane is impregnated using conventional techniques, such as  
5 spraying, painting or immersion or any other conventional technique.

In a preferred embodiment, the stimulation molecule comprises at least one RGD motif, preferably, the stimulation molecule is a natural or synthetic protein or peptide or a fusion or a mixture thereof, more preferably the stimulation molecule is selected from the group consisting of collagen proteins such as types II, VI, IX, and  
10 XI, proteoglycans such as aggrecans, decorin, fibromodulin and biglycan, and non-collagenous proteins such as cryoprecipitate, fibronectin, vitronectin, fibronogen, fibrillin, kistrin, echistatin, von Willebrand factor, tenascin and anchorin CII, and even more preferably, the stimulation molecule is selected from the group consisting of collagen type II and fibronectin. Additionally, the stimulation molecule is  
15 attached to a support.

The final concentration of the stimulation molecule is not critical and is dependent on the degree of the defect to be treated. The stimulation molecule may be added to a final concentration within the range of nM to mM, preferably between, 1nM to 100 mM and more preferably 10 mM

20 According to another embodiment of the invention, the interface membrane may be used for the treatment of bone and cartilage defects using arthroscopy. The interface membrane used for arthroscopy comprising of at least one first sealing portion component as defined hereinafter.

Further characteristics of the interface membrane for use in arthroscopy is as  
25 defined above for the interface membrane used for treatment of bone and cartilage defects, such as chondral lesions or osteochondral lesions, osteochondritis dissecans (OCD), chondromalacia and osteoarthritis

In another embodiment of the present invention the interface membrane is used for the preparation of a kit containing an interface membrane alone or in  
30 combination with at least one cartilage membrane for the treatment of bone defects or bone and cartilage defects. Furthermore, the kit may comprise other components useful for the treatment of cartilage defects or bone and cartilage defects in mammals, such as chondral lesions or osteochondral lesions, osteochondritis dissecans (OCD), chondromalacia and osteoarthritis.

35

Method for the propagation of multipotent mesenchymal mammal stem cells to be used for the treatment of cartilage or cartilage and bone defects in mammals.

In another aspect, the invention relates to a method for the propagation of multipotent mesenchymal mammal cells and/or precursor cells and their differen-

tiation into chondroblasts/chondrocytes, osteoblasts/osteocytes, fibroblasts, myoblasts/myocytes and adipoblasts/adipocytes without the use of enzymes, such as collagenase. The differentiated cells may be used for the treatment of cartilage and/or bone and cartilage defects in mammals.

- 5           The method comprises harvesting mesenchymal and/or precursor cells from a source such as bone marrow, perichondrium, periosteum, blood, blood vessels or muscle; adding the harvested cells to a cell culture flask comprising at least one growth medium as defined above under the term "growth medium";  
growing the harvested cells until colony forming units with a cell number size in the  
10 ranging order of 10-20 000 cells /clones are formed with fibroblastic phenotype (CFU-f); transferring the CFU-f cells into a new cell culture flask comprising at least one selection medium as defined above for further differentiation into chondroblasts/chondrocytes, osteocytes/osteoblasts or myoblasts/myotubes;  
harvesting of the differentiated cells and preparation of chondroblast/chondrocyte or  
15 osteocyte/osteoblast suspensions.

- Preferably, the chondroblast/chondrocyte or osteocyte/osteoblast suspensions may be used for the treatment of cartilage and/or bone and cartilage defects in mammals. The period of cultivation is dependent on the stage and conditions of the harvested mesenchymal and/or precursor cells from mammals and it is therefore  
20 difficult to define the time period used for the propagation of the mesenchymal and/or precursor cells in the growth and selection medium to be differentiated into chondroblast/chondrocytes or osteoblasts/osteocytes. The immature cells are primed by selection medium, in which the composition of amino acids, hormonal, growth- and differentiation factors are more specific for selection than for growth. It could  
25 be a certain batch of fetal calf serum at a higher concentration than conventionally used (over 10%), up to 30% v/v., which has been tested for its ability to differentiate cells into chondroblasts/chondrocytes, or tested for its ability to differentiate cells into osteoblasts/osteocytes. We have internally identified said batches of fetal calf serum that exhibits these selection patterns. Until further a new batch or new  
30 batches of fetal calf serum has to be tested for the differentiation of cells. The cells are identified by quantitative PCR of the mRNA (Lane Smith, R., et al., J. Rehab. Research and Development March/April 2000, vol 37), and in case of chondrocyte lines, the cells are tested using monoclonal antibodies such as collagen type II Ab-1 (Clone 5B2.5) mouse monoclonal antibody (Lab. Vision Corp, Fremont,  
35 California).

          The use of medium with fetal calf serum identified as sufficient "selection quality" leads to certain differentiations of the precursor cells. Other factors such as physical factors, e.g. adhesion to certain plastic materials or adhesion to cellular or non-cellular adhesion factors are also aiding to the differentiation of the cells.

Preferably the chondroblast/chondrocyte and the osteoblast/osteocyte suspensions contain conventional culture medium such as for example DMEM/F12, serum such as fetal calf serum or autologous serum, preferably a serum, which is non-immunogenic and more preferably the chondroblast/chondrocyte and the  
5 osteoblast/osteocyte suspensions comprise chondroblast/chondrocyte respectively osteoblast/osteocyte cells within the range of 100.000 to 10 million cells/ml of the total cell suspensions.

Another embodiment according to the invention relates to a cell cultivating system built on the concept of using the cartilage matrix as the "binding and de-  
10 livery" (or reservoir) system of growth and differentiation factors to the various cells present in the extracellular matrix, without using enzymatic treated and dissected cartilage pieces. This means, by adding growth factors and differentiation factors though fetal calf serum or separately, cartilage explants are capable of binding these factors via natural binding proteins present in the matrix. Such a  
15 binding and delivery system might increase the half life time of the various growth and differentiation factors present in the culture medium with fetal calf serum meaning that growth and differentiation factors are much more protected from proteolysis when first bound to natural intermediate matrix molecules the delivery "vehicles" to the various cell receptors. Additionally, a higher stimulation of the  
20 cells by growth and differentiation factors, could be speculated, because of a higher local accumulation (higher concentration) of the growth and differentiation factors around the pericellular rim, in the territorial as well as in the interterritorial compartments, compared to the growth and differentiation factors present in conventional medium. A higher local concentration of the growth and differentiation  
25 factors, bound to its natural intermediates in the matrix and later "delivered" to the binding receptors (IGF-R, TGF-R, bFGF-R etc.), induce receptors to cluster formation on the plasma membrane and further signal transduction - growth stimulation. For the growth of the various stimulated cells in the matrix, it is a much more gentle process for the cells to start their propagation and maturation in the  
30 natural extracellular matrix, instead of "stripping" off the chondroblast/chondrocytes from its natural matrix components (the cells "history") by the conventional collagenase digestions method. The ability of the chondroblast/chondrocytes to remain viable in cartilage explants in the absence of fetal calf serum or other added growth factors further suggests that the chondrocytes are protected by the extra-  
35 cellular matrix. A tissue culture system with cartilage explants as the starting material for cell propagating, has a number of other advantages over general chondrocyte culture methods. As earlier mentioned, cartilage derived cells in the explants maintain their differentiated state in the matrix while cell stimulation and cell propagation proceed. Second, the cells are not exposed to high concentration of

proteolytic activity used for instance by collagenase digestion of cartilage matrix. This means that the extracellular matrix in the process of propagating the cartilage derived cells is conserved and close to *in vivo* conditions.

#### 5 Sealing portion

The sealing portion may be used to entrap a chondroblast/chondrocyte suspension into a cartilage free cavity and/or an osteoblast/osteocyte suspension into a bone free cavity. Examples of the sealing portions are found in figure 1, reference 6 entrapping the chondroblast/chondrocyte suspension (8) into the  
10 cartilage free cavity (7), and the sealing portion in figure 2, reference (25) entrapping the osteoblast/osteocyte suspension (24) into the bone free cavity (23). Example of a sealing portion is Tisseel™ (Baxter Immuno Austria, a lyophilised virus-inactivated substance that consist of fibrinogen, plasmafibrinectin, factor VIII and plasminogen), which during application is mixed with aprotinin solution,  
15 thrombin 4, thrombin 500 and calcium chloride solution, using a dual syringe system connected to one blunt injection needle. Additionally, the "sealing portion" may comprise a chondroblast/chondrocyte or an osteoblast/osteocyte suspension with or without a stimulation molecule as defined above under the definitions. Another example of a sealing agent is a CoSeal (Cohesion Technologies, Palo Alto,  
20 California, U.S.A), which also is a two-component biological glue, resembling Tisseel, can be used instead of Tisseel.

Furthermore, when the sealing portion is glue comprising two different components, two components that together form glue. One of the components comprising at least one stimulation molecule as defined above may be applied to  
25 cover the complete area of at least one side of the membrane. The other component is added between the sealing portion part of the membrane and the edge of the defected cartilage or bone defect after the membrane is placed onto the cartilage or bone defect.

#### 30 Treatment of cartilage defects.

In another aspect, the invention relates to method and materials for *in vivo* repair of cartilage defects in mammals, such as such as chondral lesions or osteochondral lesions, osteochondritis dissecans (OCD), chondromalacia and osteo-  
arthritis.

35 Reference is now made to Figure 1.

The cartilage-defect part is normally a surface part where the original cartilage has been torn apart. As a preparation for the repair, the defect is debrided so that the cartilage defect surface part appears as a cartilage free cavity 7, which often

extending down to the interface 3, the interface in between the cartilage 2 and the bone 4, the cartilage-free cavity 7 being surrounded by healthy cartilage 2.

Thereafter, the cartilage membrane 5 as defined above is applied over the cartilage free cavity 7. The cartilage membrane 5 is normally adapted in size so that the portion part of the membrane can be sutured to the surrounding articular surface 1. After application and suturing of the cartilage membrane 5, the edge of the membrane is normally sealed to the surrounding articular surface 1 by means of suitable sealing portions 6. The sealing is not completed; a small part of the circumference is left unsealed to allow the implantation of a chondroblast/chondrocyte suspension 8. Thereafter the cartilage membrane 5 is completely sealed by means of a suitable sealing portion 6.

The cartilage membrane 5, having at least one surface part, carrying a composition comprising at least one stimulation molecule which is capable of inducing a signal transduction in chondroblasts/chondrocytes resulting in the chondroblasts/chondrocytes producing and secreting matrix components which form hyalin or hyalin articular cartilage. The surface part of the cartilage membrane 5 carrying the stimulation molecule is localised against the articular surface 1 and covering the cartilage free cavity 7 comprising the chondroblast/chondrocyte suspension 8 as defined above. Further characteristics of the "cartilage membrane" as defined above under Cartilage membrane carrying a stimulation molecule.

In another embodiment according to the invention a composition is applied on the cartilage defect surface forming the walls surrounding the cartilage free cavity 7 prior to application of the cartilage membrane 5. The composition comprise at least one stimulation molecule as defined above to increase the exposure of the implanted chondroblasts/chondrocytes in the chondroblast/chondrocyte suspension 8 to the stimulation molecule, as well as the capability of the implanted chondroblasts/chondrocytes cells to bind to the surrounding cartilage 2.

Additionally, the chondroblast/chondrocyte suspension 8 is applied simultaneously with or without a suspension comprising the stimulation molecule as defined above. Preferably, the chondroblast/chondrocyte suspension is a suspension of autologous chondrocytes/chondroblasts.

In another embodiment according to the invention the chondroblasts/chondrocytes is included in a composition carried by the cartilage membrane 5 and optionally applied directly onto the cartilage free cavity 7 in order to obtain a lining of cells resulting in a normal cartilage surface layer and transitional layer.

Preferably the chondroblast/chondrocyte suspension" contain conventional culture medium such as for example DMEM/F12, serum such as fetal calf serum or autologous serum, preferably a serum, which is non-immunogenic and more preferably the chondroblast/chondrocyte suspension comprise

chondroblast/chondrocyte cells within the range of 100.000 to 10 millions of cells/ml of the total chondroblast/chondrocyte suspension.

Examples of conditions resulting in cartilage defects, which may be treated according to the invention are chondreal lesions or osteochondral lesions, osteo-  
5 chondritis dissecans (OCD), chondromalacia and osteoarthritis.

#### Treatment of bone and cartilage defects.

A particular embodiment of the invention relates to method and materials for *in vivo* repair of both bone and cartilage defects in mammals, such as such as chon-  
10 dral lesions or osteochondral lesions, osteochondritis dissecans (OCD), chondromalacia and osteoarthritis using two membranes.

Reference is now made to figure 2.

As a preparation for the repair, the bone and cartilage defect parts is debrided so that the bone and cartilage defect parts appears as bone and cartilage free cavities  
15 23, 70 extending all way through the cartilage 20, interface 30 and down to the bone 40. The bone and cartilage free cavities 23, 70 being surrounded by healthy cartilage 20, interface 30 and bone 40. The interface membrane 21 is applied over the bone free cavity 23 at the level of the interface 30 for the ability to separate the cartilage 70 and the bone 23 free cavities. The interface membrane 21 is applied so  
20 that the first surface part 22 of the interface membrane 21, facing the bone free cavity 23 and the second surface part 26 facing the cartilage free cavity 70. The interface membrane 21 is normally adapted in size so that the portion part of the membrane can be sutured to the surrounding area of the interface 30. After application and suturing of the interface membrane 21, the edge of the membrane is  
25 normally sealed to the surrounding interface 30 by means of suitable sealing portions 25. The sealing is not completed a small part of the circumference is left unsealed to allow the implantation of an osteoblast/osteocyte suspension 24. After implantation of the osteoblast/osteocyte suspension 24 the interface membrane is completely sealed to the surrounding interface 30 by means of a suitable sealing  
30 portion 25.

The interface membrane 21 having at least two different surface parts, a first 22 and a second 26 surface part, which carries at least one stimulation molecule capable of inducing a signal transduction. The first surface part 22 of the interface membrane 21 has the ability to bind osteoblasts/osteocytes and the second surface  
35 part 26, of the interface membrane 21 has the ability to bind chondroblasts/chondrocytes.

Further characteristics of the interface membrane as defined above under Interface membrane carrying a stimulation molecule.

Additionally, the osteoblast/osteocyte suspension is applied simultaneously with or without a suspension comprising the stimulation molecule as defined above. Preferably the osteoblast/osteocyte suspension is a suspension of autologous osteoblasts/osteocytes.

5 Preferably the osteoblast/osteocyte suspension contain conventional culture medium such as for example DMEM/F12, serum such as fetal calf serum or auto-  
10 logous serum, preferably a serum, which is non-immunogenic and more preferably the osteoblast/osteocyte suspension comprise osteoblast/osteocyte cells within the range of 100.000 to 10 millions of cells/ml of the total osteoblast/osteocyte  
10 suspension.

In another embodiment of the invention the osteoblasts/osteocytes in the osteoblast/osteocyte suspension 24 is included in the composition carried by the surface part 22 of the interface membrane 21 and optionally applied directly on the bone free cavity 23 in order to obtain a lining of cells resulting in a normal bone  
15 surface layer and transitional layer.

Thereafter, the cartilage membrane 50 as defined above is applied over the cartilage free cavity 70. The cartilage membrane 50 is normally adapted in size so that the portion part of the membrane can be sutured to the surrounding articular surface 10. After application and suturing of the cartilage membrane 50, the edge of  
20 the membrane is normally sealed to the surrounding articular surface 10 by means of suitable sealing portions 60. The sealing is not completed a small part of the circumference is left unsealed to allow the implantation of a chondro-  
blast/chondrocyte suspension 80. Thereafter the implantation is completely sealed to the surrounding articular surface 10 by means of a suitable sealing portion 60.

25 The cartilage membrane 50, having at least one surface part, carrying a composition comprising at least one stimulation molecule which is capable of inducing a signal transduction in chondroblasts/chondrocytes resulting in the chondroblasts/chondrocytes producing and secreting matrix components which form hyalin or hyalin articular cartilage. The surface part of the cartilage membrane  
30 50 carrying the stimulation molecule is localised against the articular surface 10 and covering the cartilage free cavity 70 comprising the chondroblast/chondrocyte suspension 80 as defined above. Further characteristics of the cartilage membrane as defined above under Cartilage membrane carrying a stimulation molecule.

The chondroblast/chondrocyte suspension may be applied simultaneously  
35 with or without a suspension comprising of the stimulation molecule as defined above.

In another embodiment according to the invention the chondro-  
blasts/chondrocytes in the chondroblast/chondrocyte suspension 80 included in a composition carried by the cartilage membrane 50 and optionally applied directly

on the cartilage free cavity 70 in order to obtain a lining of cells resulting in a normal cartilage surface layer and transitional layer.

Preferably the chondroblast/chondrocyte suspension contain conventional culture medium such as for example DMEM/F12, serum such as fetal calf serum or autologous serum, preferably a serum, which is non-immunogenic and more preferably the chondroblast/chondrocyte suspension comprise chondroblasts/chondrocytes within the range of 100.000 to 10 millions of cells/ml of the total chondroblast/chondrocyte suspension.

Examples of conditions resulting in bone and cartilage defects, which may be treated according to the invention are chondral lesions or osteochondral lesions, osteochondritis dissecans (OCD), chondromalacia and osteoarthritis.

According to another embodiment of the invention the bone and cartilage defect is treated using arthroscopy using a two component sealing portion, component 1 and 2. Example of a two component sealing portion is Tisseel Duo Quick (Baxter). The interface membrane 21 is pretreated with a sealing portion component 1, for example a thrombin solution which contains: 500 IU thrombin, 50 mg mammal plasma protein, 40 mol calcium chloride, 10 mg sodium chloride, 3 mg glycine, and water for injection to 1 ml, such as Tisseel Duo Quick (Baxter). Additionally the sealing portion may comprise a stimulation molecule.

As a preparation for the repair, the bone and cartilage defect parts is debrided so that the bone and cartilage defect parts appears as a bone and cartilage free cavity 23, 70 extending all way through the cartilage, interface and down to the bone. The bone and cartilage free cavity being surrounded by healthy cartilage 20, interface 30 and bone 40. A sealing portion component 2 is applied to the surrounding edges of the interface area 30. The interface membrane 21 is applied using arthroscopy over the bone free cavity 23 at the level of the interface 30 for the ability to separate the cartilage 70 and the bone 23 free cavities. The interface membrane 21 is applied so that the first surface part 22 of the interface membrane 21, facing the bone free cavity part 23 and the second surface part 26 facing the cartilage free cavity 70. The interface membrane 21 is normally adapted in size so that the portion part of the membrane can be glued to the surrounding area of the interface 30. After application of the interface membrane 21, the sealing portion component 1 and 2 react with each other and from a glue sealing the interface membrane 21 to the surrounding interface area 30. The sealing is not completed a small part of the circumference is left unsealed to allow the implantation of an osteoblast/osteocyte suspension 24. After implantation of the osteoblast/osteocyte suspension 24 the interface membrane is completely sealed to the surrounding interface 30 by means of a suitable portion 25. Thereafter the chondroblast/chondrocyte suspension 80 is implanted and the articular surface sealed by means of a suitable portion 60.

The principles of the invention are further illustrated in the appended drawings.

The subsections below describe the components to be used in the methods of this invention.

5

#### Materials and Methods

Growth medium; DMEM/F12 containing 20 % fetal calf serum. DMEM/F12 obtained from Life Technologies Inc., Rockville, MD, USA and fetal calf serum from Life Technologies Inc., Rockville, MD, USA.

10

#### EXAMPLE 1

##### Chondrocyte suspension used for the treatment of cartilage defects.

Biopsy of healthy looking cartilage (200–500 mg) is obtained through an arthroscope from a minor load bearing area of the joint under aseptic conditions and placed in a sterile flask containing “Transport medium” (DMEM/F12 with 20% fetal calf serum). The Flask containing Transport medium is delivered within 48 hours to the Cell Culturing Laboratory for further processing into cell culture. The method described in example 3 was used for the propagation of the chondrocytes. The chondrocytes were expanded in tissue culture flasks in a CO<sub>2</sub> incubator (5% CO<sub>2</sub>) at 37°C in growth medium for 3 to 6 weeks, and later on maintained in DMEM/F12 with the patient’s (mammal) own heat inactivated serum (range 10-20%) for 3 to 10 days. When the chondrocyte culture has been expanded to the amount of cells needed for the repair of a cartilage lesion(s) of a given patient (mammal), the cells are harvested by trypsinization in 0.25% trypsin in 1mM EDTA, washed in medium containing fetal calf serum (10 20%) and centrifuged at 900 x g for 10 minutes at room temperature, and resuspended to cell numbers between 0.5 to 2 x 10<sup>6</sup> cells per 0.1 ml growth medium (5 to 20 x 10<sup>6</sup> cells per 1 ml growth medium). The optimum cell count per 0.1 ml growth medium for implantation is around 1 million cells. In general, a cartilage defect has room for 0.1 ml cell suspension per 1 cm<sup>2</sup> defect.

The chondrocytes are delivered to the orthopedic surgeon, who, within 24 hours implants the chondrocytes into a cartilage defect. Prior to the implantation the surgeon has either placed a periosteal flap or a suitable biodegradable cover over the defect, sutured and sealed the flap, except for the injection site. The cells are then injected under the cover, and the injection site is sealed using Tisseel Duo Quick (Baxter).

35

## EXAMPLE 2

Stimulation molecule

Collagen II was purified from large scale culturing of porcine chondrocytes as well as proteoglycans derived from the same porcine cartilage source. Collagen II  
5 was obtained from large scale culturing of mammalian chondrocytes (preferably species specific to the recipient of the cells), cultured as explants whereby the adequate amount of Collagen II is present.

## EXAMPLE 3

10 Protocol for cultivating cartilage explants to a monolayer culture:

A cartilage biopsy is harvested from the patients knee and immediately transferred into aseptic growth medium, supplemented with L-ascorbic acid [50  $\mu\text{g/ml}$  (300  $\mu\text{mol/l}$ )] and gentamicin sulfate [50  $\mu\text{g/ml}$  (10  $\text{mmol/l}$ )], Fungizone [2  $\mu\text{g/ml}$  (2.2  $\mu\text{mol/l}$ )] in tissue culture flasks. The cartilage biopsy is then washed  
15 carefully with new growth medium and dissected in growth medium into 2-4 mm cartilage pieces (explants). When initially placed in the culture, it takes the cartilage explants approximately several days depending on donor material, to reach a constant metabolic state. Having reached such a steady state (steady state is a balance between synthesis and catabolism), the pre chondroblasts/ chondroblasts are now  
20 stimulated by growth factors present in the growth medium, which diffundate through the cartilage matrix and bind to various binding proteins present in the matrix as well as binding directly to the selective cell receptors

The stimulated and proliferating cells remain in the explants usually for one to two weeks (depending on the donor material) and then "leave" the explants, via  
25 cell migration, into the culture medium for further attachment to the culture dish (monolayer culture).

Before reaching cell confluence, the cartilage explants are transferred to separate culture dishes with new growth medium, and the first established monolayer culture is split by conventional trypsination method, described earlier. This  
30 step is important in the process of propagating the cell culture to a high cell number. After each trypsination process, the monolayer cells new growth medium is added to the monolayer cells as described above.

After 3-5 weeks of final cell cultivating, all cartilage explants are discarded and the monolayer cultures are washed several times with phosphate buffered saline  
35 (PBS). Autologous growth medium containing 10% mammal serum is added to the cell culture for further 2-3 days cell cultivating before the cells are delivered to the clinic or hospital.

## EXAMPLE 4

Membrane to be used for the treatment and use of the membrane

During open knee surgery, a membrane collagen type I/(III) is used, purchased from Geistlich Biomaterials, Wolhusen, Switzerland or from Baxter (Denmark). The membrane is cut into a size, which is somewhat larger than the cartilage defect, so that the membrane can cover the cartilage defect and extend around ½ cm beyond the rim of the defect. The membrane is sutured together with the cartilage rim. The border between the membrane and the cartilage is sealed using Tisseel Due Quick (Baxter). The collagen type I membrane is pretreated with a 1-5 ml collagen type II solution (3-10 mg collagen II/ml (Dep. Matrcial Engineering, Drexel University, Philadelphia, Pennsylvania) for 5-15 minutes at room temperature prior to use for implantation.

a) When performing arthroscopic surgery, the surface of the collagen I/(III) membrane, which is facing the cartilage defect is pretreated with component II a thrombin solution which contains: 500 IU thrombin, 50 mg mammal plasma protein, 40 mol calcium chloride, 10 mg sodium chloride, 3 mg glycine, and water for injection to 1 ml, as for instance one part of the Tisseel Duo Quick (Baxter).

b) Under arthroscopy using distention of the joint with gases such as for instance CO<sub>2</sub> instead of distention with solutions such as for instance 0.9% sodium chloride solution, the healthy cartilage creating the rim around the defect is coated with component I which is composed of clottable protein, 75-115 mg thereof 70-110 mg fibrinogen, 2-9 mg fibronectin, 10-50 IU factor XIII, 40-120 g, 3000 KIU aprotinin (bovine), 10-20 mg mammal albumin, 15-35 mg glycine, 2-4 mg sodium chloride, 4-8 mg sodium citrate, 0.2-0.4 mg polysorbate 80, 15 mg creatine monohydrate, and water for injection to 1 ml for instance the other composition of Tisseel.

The above described thin layer membrane coated as described with "II" is then inserted over the defect (the size of the membrane is somewhat larger in diameter than the defect) is placed with the coat facing the defect. When the membrane gets into contact with the coated cartilage rim of the defect described as coated with "II", the two types of coating (coating "I" and coating "II", which is the components in Tisseel) will result in a biological glue and thereby attaching the membrane to the defect. The membrane is held in place by inserting small absorbable pins into the periphery of the defect anchoring the "sealed" membrane to the cartilage in a more solid manner. The chondrocyte suspension is then injected via a needle in one area of the membrane near the rim into the defect, and the membrane hole is sealed, when pulling the needle, with the two component biological glue such as for instance Tisseel Duo Quick as shown below.

In order to perform the above described arthroscopic procedure, we have in this example used a 2 component biological glue, where component "II" is used as coat on the membrane facing the defect and where component "I" is used as coat on the cartilage rim surrounding the defect. Component "II" will react with component "I", but will not react as glue with medium containing the autologous serum component, but as RGD coat towards the medium, and thereby induce adherence and matrix production of the injected chondrocytes.

The Tisseel 2 component glue can also be used as coat on the membrane part facing the defect, but will be more difficult to handle when inserted. Another alternative is to coat the cartilage rim surrounding the defect with the two component glue. In this case it will also be difficult to handle the placement of the membrane over the defect.

Tisseel Duo Quick consists of

- I: clottable protein, 75-115 mg thereof 70-110 mg fibrinogen, 2-9 mg fibronectin, 10-50 IU factor XIII, 40-120 g, 3000 KIU aprotinin (bovine), 10-20 mg mammal albumin, 15-35 mg glycine, 2-4 mg sodium chloride, 4-8 mg sodium citrate, 0.2-0.4 mg polysorbate 80, 15 mg creatine monohydrate, and water for injection to 1 ml.
- II: The thrombin solution contains: 500 IU thrombin, 50 mg mammal plasma protein, 40 mol calcium chloride, 10 mg sodium chloride, 3 mg glycine, and water for injection to 1 ml.

#### EXAMPLE 5

##### Chondrogenesis of cells in Cambium by proteins containing RGD motifs

Two samples of a periosteal flap from pigs were examined with two different culture medium approaches, one being the growth medium, and a so-called "Conditioned Medium", consisting of the growth medium and 1-20% v/v collagen II. This conditioned medium was used as capable of performing transduction. After conditioning of the medium was completed, this Condition Medium was frozen to -20°C until use.

The growth medium was used as the control medium incapable of inducing chondrocyte formation in the cambium layer of a periosteal flap.

Two samples of a periosteal flap, ½ x ½ cm in size obtained from the medial part of tibia of a pig were placed in two tissue culture dishes. The conditioned medium was thawed, centrifuged at 3000 rpm for 20 minutes and sterile filtered through a 0.8 µm filter and subsequently applied to one of the samples of periosteum. Incubated at 37°C, in a CO<sub>2</sub> incubator for a period of 4 weeks.

A periosteal flap, ½ x ½ cm in size obtained from the medial part of tibia of the same animal was used for the control experiment. These samples were incubated at 37°C, in a CO<sub>2</sub> incubator for a period of 4 weeks.

The two samples of periosteal flap was fixated by conventional fixating  
5 technique in formaldehyde and stained with various routine staining including Safranin and submitted to microscopic examination.

#### EXAMPLE 6

##### Differentiation of stem and/or precursor cells

10 First, aspirate from spongiosa of femur containing both hematopoietic precursor cells and marrow stromal stem and/or precursor cells were plated into cell culture tissue bottles at approximate dilutions. Single and colony forming marrow cells were stimulated 24 hours (primary incubation) with growth medium. After  
15 primary incubation, non-adherent cells such as hematopoietic as well as non-hematopoietic cells were gently removed by replacing supernatant with new media. Adherent cells was further stimulated 1 week with above growth medium which induced several colony forming units with cell number sizes ranging in the order of 10-20.000 cells/clone and with fibroblastic phenotype (CFU-f).

After proliferation of these cells in growth medium for another week or more  
20 (depending on donor material) some cell cultures were transferred the selection media, are more specific for selection than for growth. It could be a certain batch of fetal calf serum at a higher concentration than conventionally used (over 10%), up to 30% v/v., which has been tested for its ability to differentiate cells into chondroblasts/chondrocytes, or tested for its ability to differentiate cells into osteo-  
25 blasts/osteocytes. We have internally identified said batches of fetal calf serum that exhibits these selection patterns. Until further a new batch or new batches of fetal calf serum has to be tested for the differentiation of cells. The cells are identified by quantitative PCR of the mRNA (Lane Smith, R., et al., J. Rehab. Research and Development March/April 2000, vol 37), and in case of chondrocyte lines, the cells  
30 are tested using monoclonal antibodies such as collagen type II Ab-1 (Clone 5B2.5) mouse monoclonal antibody (Lab. Vision Corp, Fremont, California) for further differentiation and "cell maturation" (2-4 weeks in selection media).

Additionally, developed bone cells were shown to produce mineralized matrix, chondroblast/chondrocytes to form characteristic lacunas where matrix was  
35 stained metachromatic with dye such as Safranin-O.

## THE CLAIMS DEFINING THE INVENTION ARE AS FOLLOWS:

1. A cartilage membrane having at least one surface part carrying a composition comprising at least one stimulation molecule selected from the group consisting of collagen proteins, proteoglycans, and non-collageneous proteins.
- 5 2. A cartilage membrane according to claim 1, wherein the stimulation molecule is a collagen protein selected from the group consisting of collagen II, VI, IX and XI.
3. A cartilage membrane according to claim 1, wherein the stimulation molecule is a proteoglycan selected from the group consisting of aggrecans, decorin, fibromodulin and biglycan.
- 10 4. A cartilage membrane according to claim 1, wherein the stimulation molecule is a non-collageneous protein selected from the group consisting of cryoprecipitate, fibronectin, vitronectin, fibrinogen, fibrillin, kistrin, echistatin, von Willebrand factor, tenascin and anchorin CII.
5. A cartilage membrane according to any one of claims 1-4, which is a non-  
15 immunogenic, non-toxic, biodegradable membrane.
6. A cartilage membrane according to claims 1 or 5, wherein the membrane material is porous or substantially porous.
7. A cartilage membrane according to claim 6, wherein the membrane is a natural or synthetic collagen type I membrane or part thereof.
- 20 8. An interface membrane with a first surface part and a second surface part both carrying a composition comprising at least one stimulation molecule which is selected from the group consisting of collagen proteins, proteoglycans, and non-collageneous proteins.
9. A membrane according to claim 8, wherein the stimulation molecule is a  
25 collagen protein selected from the group consisting of collagen II, VI, IX and XI.
10. A membrane according to claim 8, wherein the stimulation molecule is a proteoglycan selected from the group consisting of aggrecans, decorin, fibromodulin and biglycan.
11. A membrane according to claim 8, wherein the stimulation molecule is a non-  
30 collageneous protein selected from the group consisting of cryoprecipitate, fibronectin, vitronectin, fibrinogen, fibrillin, kistrin, echistatin, von Willebrand factor, tenascin and anchorin CII.
12. An interface membrane according to any one of claims 8-11, which is a non-immunogenic, non-toxic, biodegradable membrane.
- 35 13. An interface membrane according to claims 8 or 12, wherein the membrane material is porous or substantially porous.

14. An interface membrane according to claim 13, wherein the membrane is a natural or synthetic collagen type 1 membrane or part thereof.
15. A membrane according to any one of the claims 1-14, wherein the stimulation-molecule comprising at least one RGD motif.
- 5 16. A membrane according to claim 15, wherein the stimulation molecule is a natural or synthetic protein or peptide or a fusion or a mixture thereof.
17. A membrane according to claim 16, wherein the stimulation molecule is selected from the group consisting of collagen type II and fibronectin.
18. A membrane according to claim 17, wherein the stimulation molecule is  
10 attached to a support.
19. A kit for cartilage repair comprising at least one cartilage membrane according to any one of claims 1-7 and at least one stimulation molecule according to any one of claims 1-4, 9-11, 15-18.
20. A kit according to claim 19 comprising at least one interface membrane  
15 according to any one of claims 8-14.
21. Use of at least one membrane according to any one of claims 1-18 for the preparation of a kit according to any one of claims 19 or 20 for the treatment of a mammal having cartilage defects or bone and cartilage defects.

20

Dated this nineteenth day of November 2004

Interface Biotech A/S  
Patent Attorneys for the Applicant:

F B RICE & CO

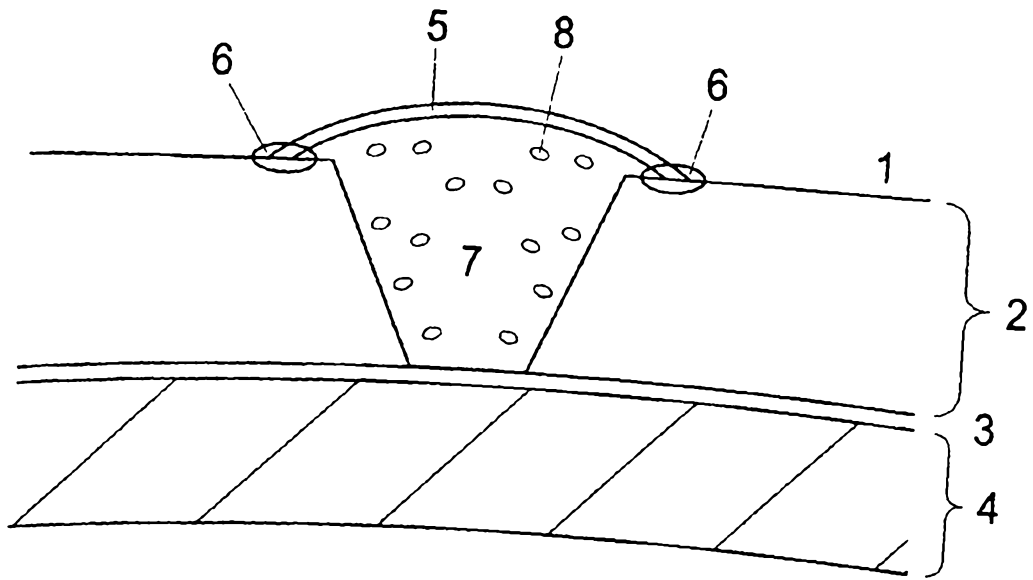

Fig. 1

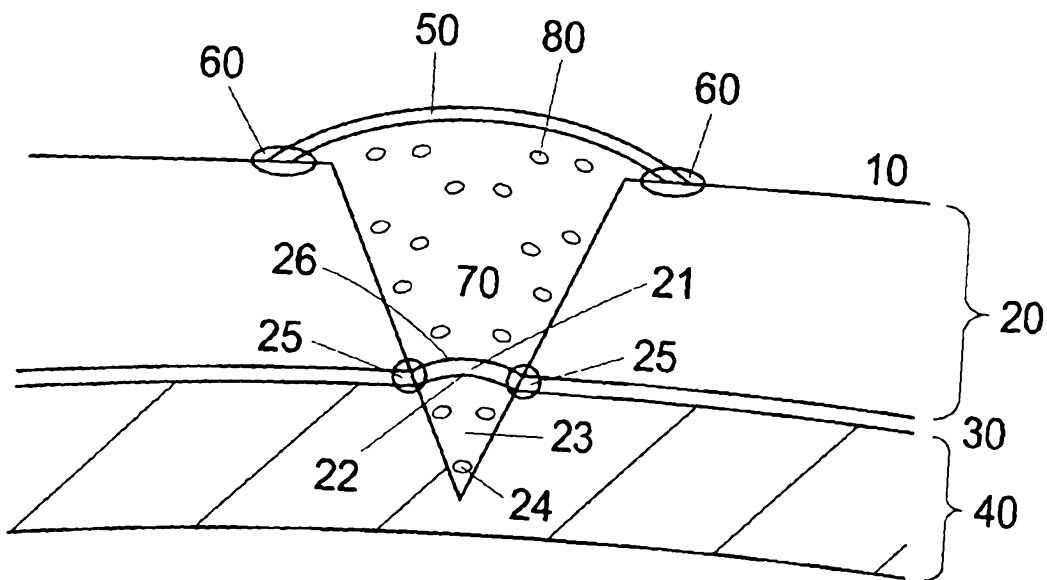

Fig. 2