

May 30, 1961

R. H. MONROE ET AL

2,986,439

KNOCKDOWN ARTICLE OF FURNITURE

Filed Feb. 16, 1959

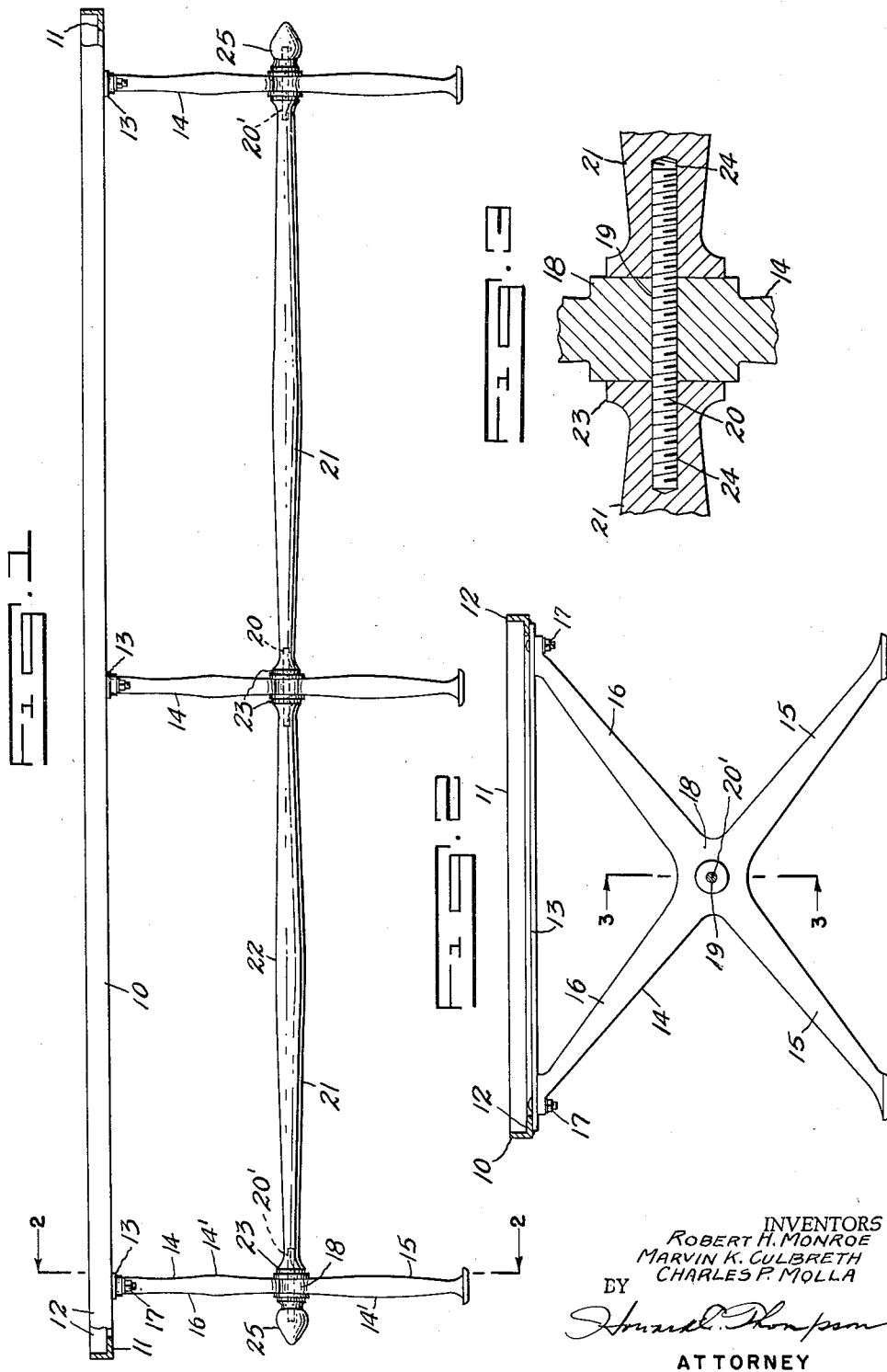

INVENTORS
ROBERT H. MONROE
MARVIN K. CULBRETH
CHARLES P. MOLLA
BY
Howard Thompson
ATTORNEY

1

2,986,439

KNOCKDOWN ARTICLE OF FURNITURE

Robert H. Monroe, East Orange, N.J., Marvin K. Culbreth, Wilton, Conn., and Charles P. Molla, Old Westbury, N.Y., assignors to Molla Incorporated, Westbury, N.Y., a corporation of New York

Filed Feb. 16, 1959, Ser. No. 793,624

3 Claims. (Cl. 311—35)

This invention relates to a knockdown article of furniture, comprising a metal frame, wherein the same can be utilized as a table, seat, bench or the like. More particularly, the invention deals with a structure of the character described, wherein two or more crossed cast leg frames are employed and coupled with a rectangular top or supporting frame, in conjunction with a cast spacer and bracing rod engaging and spacing the leg frames in providing a sturdy article of furniture of the character described.

The novel features of the invention will be best understood from the following description, when taken together with the accompanying drawing, in which certain embodiments of the invention are disclosed and, in which, the separate parts are designated by suitable reference characters in each of the views and, in which:

Fig. 1 is a side view of an article of furniture made according to our invention, with parts of the construction broken away and in section.

Fig. 2 is a section substantially on the line 2—2 of Fig. 1; and

Fig. 3 is an enlarged partial section on the line 3—3 of Fig. 2 of the central leg unit of the furniture.

In practice, we provide an oblong, rectangular sheet metal frame 10, preferably of angle iron cross-sectional form, as noted at the ends 11, Fig. 1, and the sides 12 of Fig. 2. Welded or otherwise secured to the lower portions of the side members 12 of the frame 10 are cross-straps 13, three of which are shown in Fig. 1 of the drawing. It will be noted that the end straps are spaced with respect to the end frame members 11, so as to maintain the entire supporting structure of the frame 10 within the environment of the ends 11, as noted in Fig. 1 of the drawing.

It is pointed out, at this time, that, while in the present showing of Fig. 1 illustrating one adaptation and use of our invention we have shown a relatively long frame 10, the device can be made up with shorter frames, in other words, frames which include only two supporting leg units, instead of the three, as shown in Fig. 1, but, at all times, the ends 11 of the frame 10 will be spaced beyond the end strips 13. At this time, it is also pointed out that any type and kind of a top can be arranged within the ends and sides 11 and 12 of the frame 10. In other words, when tables are to be constructed, glass, Formica or other panels can be arranged in the frame; whereas, when seats, benches or the like are to be constructed, cushioned tops will be employed.

Now considering Figs. 1 and 2 of the drawing, it will appear that leg units 14, preferably of die cast aluminum, are employed, these units having crossed downwardly flaring leg ends 15 terminating in upwardly flaring supporting ends 16, which are bolted or otherwise secured, as at 17, to end portions of the strips 13, as clearly illustrated in Fig. 2 of the drawing, this providing the detachable mounting of the units 14.

The cross-legs provide, centrally thereof, large bearing portions 18, having a threaded aperture 19, note Fig. 3

2

of the drawing, for reception of a coupling screw 20. At 21, in Figs. 1 and 2 of the drawing, are shown two cast aluminum brace coupling and spacing members having relatively wide central portions 22 and contracted ends terminating in disc-type heads 23 and the heads 23 having threaded apertures 24, note Fig. 3 of the drawing, for reception of the screw or screws 20.

Fig. 3 actually discloses part of the central leg unit 14 illustrated in Fig. 1 and portions of the adjacent members 21. It will here be noted that a single screw 20 can be utilized to couple both members 21 with the leg unit 14.

Now, considering Fig. 1 of the drawing, it will appear that at 20' we have indicated, in dotted lines, screws mounted in opposed ends of the members 21 to operatively engage the end leg units 14 and also to receive characterized knobs 25, forming finished ends for the screws 20' and an attractive appearance at the end of the furniture, the knobs 25 being disposed within end limits of the end members 11 of the frame 10.

It will be apparent that the members 21 are detachably coupled with the leg units 14, thus the entire furniture is composed of three basic parts, namely the frame 10, at least two leg units 14 and at least one member 21, which, when detached, can be compactly packaged in a relatively thin package, the length and width of which would be defined by the length and width of the frame 10 employed.

By reason of the simple construction employed, the table, seat or bench of two distinct lengths can be produced economically and, by reason of the cast aluminum structure of the units 14 and members 21, the weight can be maintained at a minimum to facilitate handling and movement of the furniture when in set-up condition.

Considering Fig. 2 of the drawing, it will appear that the ends 15 and 16 of the units 14 are relatively wide at the bearing portion 18 and contract in the direction of the ends thereof. However, noting Fig. 1 of the drawing, it will appear that the central portions of the ends 15 and 16 are transversely enlarged, as indicated at 14' to reinforce and strengthen these ends.

Having fully described our invention, what we claim as new and desire to secure by Letters Patent is:

1. An article of furniture, comprising a rectangular top supporting frame, defined by sides and ends of angle iron cross-sectional form, means adjacent and spaced from the frame ends and permanently fixed to the frame sides for joining said frame sides, crossed one-piece leg units detachably coupled with said means adjacent the frame sides, the crossed units having, centrally thereof, a large bearing portion, including a threaded aperture, a coupling, spacing and bracing member arranged between two of said leg units, said member having, at ends thereof, threaded apertures for reception of screws projecting beyond said member for engagement with the threaded apertures of said units, and means engaging the screws, outwardly of said units, for retaining the units in firm coupling engagement with ends of said member.

2. An article of furniture, comprising a rectangular top supporting frame, defined by sides and ends of angle iron cross-sectional form, means adjacent and spaced from the frame ends and permanently fixed to the frame sides for joining said frame sides, crossed one-piece leg units detachably coupled with said means adjacent the frame sides, the crossed units having, centrally thereof, a large bearing portion, including a threaded aperture, a coupling, spacing and bracing member arranged between two of said leg units, said member having, at ends thereof, threaded apertures for reception of screws projecting beyond said member for engagement with the threaded apertures of said units, means engaging the screws, outwardly of said units, for retaining the units in firm coupling engagement with ends of said member, and one

3

of said last named means comprising a second member similar to the first member and extending to and engaging a third leg unit.

3. An article of furniture, comprising a rectangular top supporting frame, defined by sides and ends of angle iron cross-sectional form, means adjacent and spaced from the frame ends and permanently fixed to the frame sides for joining said frame sides, crossed one-piece leg units detachably coupled with said means adjacent the frame sides, the crossed units having, centrally thereof, a large bearing portion, including a threaded aperture, a coupling, spacing and bracing member arranged between two of said leg units, said member having an enlarged central portion and contracted ends terminating in disc heads, said heads having threaded apertures, screws mounted in said last named apertures and projecting be-

4

yond said heads for engagement with the threaded apertures of said units, and means engaging the screws, outwardly of said units, for retaining the units in firm coupling engagement with ends of said member.

References Cited in the file of this patent

UNITED STATES PATENTS

960,314	Guttman -----	June 7, 1910
1,104,103	Carpenter -----	July 21, 1914
1,357,050	Hathorne -----	Oct. 26, 1920
1,473,817	Corsline -----	Nov. 13, 1923
1,924,989	Hallowell -----	Aug. 29, 1933
2,616,773	Sanford -----	Nov. 4, 1952
2,622,952	Wilhide -----	Dec. 23, 1952
2,635,023	Frye -----	Apr. 14, 1953