

Nov. 18, 1924.

1,516,036

E. B. BINFORD

METHOD AND MEANS FOR FORCING STAIN AND THE LIKE INTO SHINGLES IN BUNDLES

Filed March 14, 1924

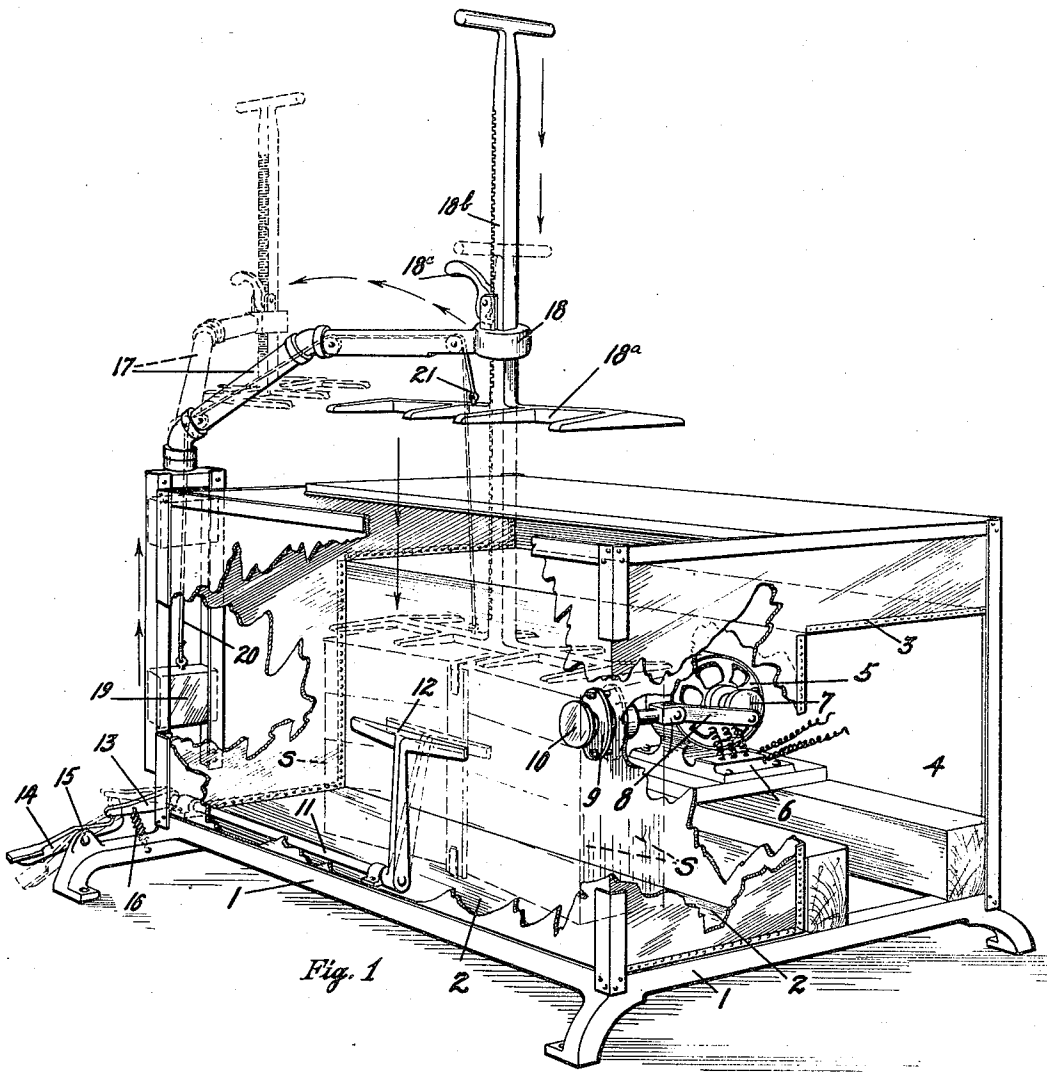

INVENTOR.  
*Edwin B. Binford*  
BY *A. Ditzberg*  
ATTORNEY.

# UNITED STATES PATENT OFFICE.

EDWIN B. BINFORD, OF PASADENA, CALIFORNIA.

## METHOD AND MEANS FOR FORCING STAIN AND THE LIKE INTO SHINGLES IN BUNDLES.

Application filed March 14, 1924. Serial No. 699,199.

*To all whom it may concern:*

Be it known that I, EDWIN B. BINFORD, a citizen of the United States, residing in the city of Pasadena, county of Los Angeles, and State of California, have invented certain new and useful Methods and Means for Forcing Stain and the like into Shingles in Bundles, of which the following is a specification.

In staining shingles with creosote, or other liquid, it is customary to dip a bundle of shingles bodily down into the liquid in order to stain or coat the same and then to subject the bundle of shingles to a whirling motion or other action in order to properly distribute the stain or liquid and to throw off any surplus liquid. This is fully described in my application, filed September 24, 1923, Serial No. 664,414.

I have invented a new method of forcing the stain into the bundle of shingles when it is dipped into the liquid and while it is submerged therein, whereby I am able to thoroughly saturate the shingles in the bundle and work the liquid or stain into the innermost portions of the shingles making up the bundle. I accomplish this by causing a vibration of the bundle of shingles in the liquid, the vibration under power tending to cause a sort of bellows action in the bundle of shingles, that is, the shingles are intermittently compressed and released, the compression forcing the air from between the shingles and the release allowing the liquid to be sucked or forced into the spaces between the shingles.

In order to fully explain my invention, I have illustrated one practical means for accomplishing the desired result, it being understood, however, that many different forms of mechanism, or instrumentalities can be used to carry out the new method constituting my invention.

In the drawings, the figure is a perspective view of one type of machine capable of performing my new method of forcing stain into a bundle of shingles.

Referring now in detail to the drawings, I will describe this particular form of the invention. A suitable base, 1, is provided for supporting a vat or container 2, for the liquid, the back wall of said vat or container being connected to a horizontal floor, 3, thus leaving a space thereunder, designated 4, in which is mounted a motor, 5, on a suitable

base or support, 6, as illustrated. The motor drives a crank, or eccentric, 7, to which is attached an arm, 8, extended through a suitable box or packing at 9, and has a head, as 10. This is hereinafter referred to as a vibrator adapted to bear against the side of a bundle of shingles, S, when placed down in the vat or container, edgewise, as illustrated.

Pivotaly mounted in said vat or container, 2, on a shaft 11, is a holding member or arm, 12, its shaft, 11, being provided at its opposite end with an arm, 13, the free end of which is attached for operation to a foot pedal, 14, pivotaly mounted on the foot of the frame, as at 15. A spring, 16, normally holds the arm 13 down, and arm 12 back against the outer wall of the vat, in a manner which will be easily understood from the drawings.

Adjustably mounted at one end of the frame, is a swinging arm, 17, carrying an adjustable depressor, 18, having the shingle-engaging frame, 18<sup>a</sup>, the rack bar, 18<sup>b</sup>, adapted to be engaged by the latch, 18<sup>c</sup>, for holding said depressor down on top of the bundle of shingles to keep said bundle of shingles immersed, or to be raised to the position shown in full lines and swung out of the way, as indicated. A weight may be provided, as at 19, sliding in a suitable guide-way, with a cable, 20, attached to the depressor, as at 21, for automatically raising the depressor when the latch 18<sup>c</sup> is released.

The operation of the mechanism above described may be briefly described as follows:

The bundle of shingles is placed edgewise down into the vat or container, 2, as indicated. The operator places his foot on the foot pedal, 14, which operates through its connections to move the arm 12, against the bundle of shingles and to press said bundle of shingles against the vibrator, 10, as will be clear. The motor 4, is then started and the vibrator is operated rapidly, causing a rapid vibration transversely through the bundle of shingles and causing the shingles to be compressed and released in such a way as to actually force, or suck, the liquid or stain into the innermost part of the bundle without releasing the binder of said bundle.

Thus I have provided a new and useful method of forcing stain or liquid into a bundle of shingles without taking the same apart, making possible a better job of staining shingles in bundles and doing it faster.

The bundle can then be subjected to a whirling motion to throw off the surplus liquid, or can be allowed to drain, as may be desired.

5 I do not limit my invention to the showing here made, except as I may be limited by the hereto appended claims.

I claim:

10 1. The method of forcing a liquid into a bundle of shingles which consists in submerging the bundle in the liquid and in compressing and releasing the same flatwise, whereby to cause the liquid to enter the spaces between the shingles.

15 2. The method of forcing a staining liquid into a bundle of shingles which consists in submerging the bundle into the liquid and then applying to said bundle of shingles, flatwise thereof, a compressing and releasing action in a vibratory manner, substantially as described.

20 3. The herein described method for forcing stain and the like into shingles in bundles which consists in submerging the bundles of shingles in the stain, and applying thereto a vibratory action flatwise thereof, whereby to compress and release alternately the shingles in each bundle, for the purpose described.

30 4. The herein described method for forc-

ing stain and the like into a bundle of shingles which consists in submerging the bundles of shingles into the stain, and causing the rapid vibration thereof while submerged in a direction through said bundle 35 of shingles flatwise thereof.

5. Means for forcing stain and the like into a bundle of articles including a container for the liquid and said bundle, a motor, and operative connections from the 40 motor to said bundle for causing an alternate compression and releasing action in said bundle, whereby to cause said liquid to penetrate between and into said articles.

6. In combination, a vat to receive liquid 45 stain and the like, said vat being large enough to receive a bundle of shingles therein, a vibrator in said vat to bear against said bundle of shingles flatwise thereof, means for holding said bundle of shingles 50 against said vibrator, and means for power operating said vibrator, substantially as described.

Signed at Pasadena, Los Angeles County, California, this 8th day of March, 1924.

EDWIN B. BINFORD.

Witnesses:

IRA J. H. SYKES,  
W. R. LITZENBERG.