

(19) World Intellectual Property
Organization
International Bureau



(43) International Publication Date
10 June 2004 (10.06.2004)

PCT

(10) International Publication Number
WO 2004/048755 A1

- (51) International Patent Classification⁷: F01D 17/10, 17/14
- (21) International Application Number: PCT/GB2003/004961
- (22) International Filing Date: 14 November 2003 (14.11.2003)
- (25) Filing Language: English
- (26) Publication Language: English
- (30) Priority Data: 0227473.6 25 November 2002 (25.11.2002) GB
- (71) Applicant and
(72) Inventor: LEAVESLEY, Malcolm, George [GB/GB]; 54 Heylyn Square, Malmesbury Road, Bow, London E3 2DW (GB).
- (74) Agent: JONES, Graham, Henry; Graham Jones & Company, 77 Beaconsfield Road, Blackheath, London SE3 7LG (GB).
- (81) Designated States (*national*): AE, AG, AL, AM, AT, AU, AZ, BA, BB, BG, BR, BW, BY, BZ, CA, CH, CN, CO, CR, CU, CZ, DE, DK, DM, DZ, EC, EE, EG, ES, FI, GB, GD, GE, GH, GM, HR, HU, ID, IL, IN, IS, JP, KE, KG, KP, KR, KZ, LC, LK, LR, LS, LT, LU, LV, MA, MD, MG, MK, MN, MW, MX, MZ, NI, NO, NZ, OM, PG, PH, PL, PT, RO, RU, SC, SD, SE, SG, SK, SL, SY, TJ, TM, TN, TR, TT, TZ, UA, UG, US, UZ, VC, VN, YU, ZA, ZM, ZW.
- (84) Designated States (*regional*): ARIPO patent (BW, GH, GM, KE, LS, MW, MZ, SD, SL, SZ, TZ, UG, ZM, ZW), Eurasian patent (AM, AZ, BY, KG, KZ, MD, RU, TJ, TM), European patent (AT, BE, BG, CH, CY, CZ, DE, DK, EE, ES, FI, FR, GB, GR, HU, IE, IT, LU, MC, NL, PT, RO, SE, SI, SK, TR), OAPI patent (BF, BJ, CF, CG, CI, CM, GA, GN, GQ, GW, ML, MR, NE, SN, TD, TG).
- Declaration under Rule 4.17:**
— of inventorship (Rule 4.17(iv)) for US only
- Published:**
— with international search report
- For two-letter codes and other abbreviations, refer to the "Guidance Notes on Codes and Abbreviations" appearing at the beginning of each regular issue of the PCT Gazette.

(54) Title: VARIABLE TURBOCHARGER APPARATUS WITH BYPASS

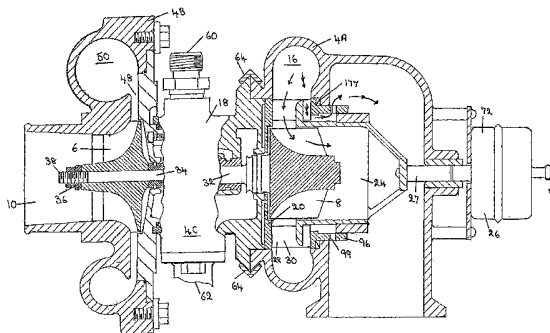

(57) Abstract: Variable turbocharger apparatus (2) comprising a housing (4), a compressor (6) mounted for rotation in the housing (4), a turbine (8) mounted for rotation in the housing (4), a first inlet (10) for enabling air to be conducted to the compressor, an outlet (12) for enabling air from the compressor to be conducted to an engine, a second inlet (14) for enabling exhaust gases from the engine to be conducted to the turbine (8) in order to rotate the turbine (8), a chamber (16) which surrounds the turbine (8) and which receives the exhaust gases from the second inlet (14) before the exhaust gases are conducted to the turbine (8), and a bearing assembly (18) for permitting the rotation of the turbine (8), the variable turbocharger apparatus (2) comprising vanes (22) which are mounted in the chamber (16) and which are for accurately directing exhaust gases on to the turbine (8), a piston (24) which is slidable and which is positioned between the housing and the turbine (8), and control means (26) which is connected to the piston (24) and which is for controlling the sliding movement of the piston (24), the piston (24) having an end (28) which is nearest the bearing assembly (18) and which defines a gap (30), the size of the gap (30) being variable in dependence upon the sliding of the piston (24) under the control of the control means (26), the size of the gap (30) being effective to control the amount of the exhaust gases that act on the turbine (8) thereby accurately controlling the speed of rotation of the turbine (8) and thereby the amount of air conducted by the compressor through the outlet (12) to the engine, and the variable turbocharger apparatus (2) having at least one bypass aperture (99) which is closed when the size of the gap (30) is at a minimum and which opens when the gap (30) reaches a predetermined size, the opening of the bypass aperture (99) being such as to allow exhaust gases that are not required for acting on the turbine (8) to bypass the turbine (8).

WO 2004/048755 A1

VARIABLE TURBOCHARGER WITH BYPASS

This invention relates to turbocharger apparatus and, more especially, this invention relates to variable turbocharger apparatus.

Variable turbocharger apparatus is known comprising a housing, a compressor mounted for rotation in the housing, a turbine mounted for rotation in the housing, a first inlet for enabling air to be conducted to the compressor, an outlet for enabling air from the compressor to be conducted to an engine, a second inlet for enabling exhaust gases from the engine to be conducted to the turbine in order to rotate the turbine, a chamber which extends around the turbine and which receives the exhaust gases from the second inlet before the exhaust gases are conducted to the turbine, a bearing assembly for permitting the rotation of the turbine, a heat shield for shielding the bearing assembly from the exhaust gases, and a control system to control the speed of the turbine. One of the problems with such known variable turbocharger apparatus is the overall range limit, whereby if all of the gases are passed through the turbine, and if the variable turbocharger apparatus is designed to operate over a large flow volume, there is a point where the low down efficiency of the variable turbocharger apparatus starts to depreciate.

It is an aim of the present invention to obviate or reduce the above mentioned problems.

Accordingly, in one non-limiting embodiment of the present invention there is provided variable turbocharger apparatus comprising a housing, a compressor mounted for rotation in the housing, a turbine mounted for rotation in the housing, a first inlet for enabling air to be conducted to the compressor, an outlet for enabling air from the compressor to be conducted to an engine, a second inlet for enabling exhaust gases from the engine to be conducted to the turbine in order to rotate the turbine, a chamber which surrounds the turbine and which receives the exhaust gases from the second inlet before the exhaust gases are conducted to the turbine, and a bearing assembly for permitting the rotation of the turbine, the variable turbocharger apparatus comprising vanes which are mounted in the chamber and which are for accurately directing exhaust gases on to the turbine, a piston which is slidable and which is positioned between the housing and the turbine, and control means which is connected to the piston and which is for controlling the sliding movement of the piston, the piston having an end which is nearest the bearing assembly and which defines a gap, the size of the gap being variable in dependence upon the sliding of the piston under the control of the control means, the size of the gap being effective to control the amount of the exhaust gases that act on the turbine thereby accurately controlling the speed of rotation of the turbine and thereby the amount of air conducted by the compressor through the outlet to

the engine, and the variable turbocharger apparatus having at least one bypass aperture which is closed when the size of the gap is at a minimum and which opens when the gap reaches a predetermined size, the opening of the bypass aperture being such as to allow exhaust gases that are not required for acting on the turbine to bypass the turbine.

The variable turbocharger apparatus of the present invention is able to operate over a larger operating range, and allows for better low down efficiency of the variable turbocharger apparatus because a smaller flow area turbine housing may be used. Also the gases are able to be guided accurately on to the turbine, even when gases are being bypassed. This design allows for a larger operating range of the variable turbocharger apparatus and a high operating efficiency.

The variable turbocharger apparatus of the present invention may be such that the end of the piston has a flange which extends radially outwardly. The flange may have slots for receiving the vanes. The slots may be open slots which extend inwardly from the periphery of the flange, or closed slots in the flange. With the slots, the flange on the end of the piston then forms a control ring that operates over the vanes.

The variable turbocharger apparatus may be one in which the flange is such as to allow gases to bypass a back face of the flange whilst still allowing accurate gas flow onto the turbine.

By using the flange, the exhaust gases are able to be guided more accurately through the vanes onto the turbine. Thus the flange enables the

performance of the variable turbocharger apparatus to be enhanced. The flange also allows gases to bypass the back face of the flange, so gases may enter into the bypass system. It should be noted that when gases are being bypassed, the flange allows the gases to be accurately guided onto the turbine, so the flow to the turbine is always operating at high efficiency. Pressure on the back face of the flange helps to keep the piston in a closed position, so that a smaller sized control means may be used. When the flange has the slots, gas leakage through the slots where the vanes are located is not a problem with the variable turbocharger apparatus of the present invention because gas pressure is the same both sides of the flange. During use of the variable turbocharger apparatus, if a carbon deposit builds up on the vanes, then this is cleaned off as the flange of the piston moves backwards and forwards over the vanes. Gas leakage is prevented when the piston is in its closed position. When the piston is in its closed position, this is the most vulnerable time for gas leakage. However, with the variable turbocharger apparatus of the present invention, all the gases are guided accurately through the vanes and the flange as required.

The variable turbocharger apparatus may include a heat shield for shielding the bearing assembly from heat from the exhaust gases. The heat shield may be a ring-shaped heat shield. Alternatively, the heat shield may be a disc-shaped heat shield having an outer ring portion, an inner wall portion, and an aperture through the inner wall portion. The heat shield may also be of a design so to allow the heat shield to float and be held in position

by spring means in order to prevent gas leakage. This design also allows for an air cooling system to be used behind the heat shield.

The vanes may be mounted on the heat shield.

The variable turbocharger apparatus may be one in which the slots are of a V-shape in order that gases are able to bypass in a controlled manner in order to prevent turbine surging.

The variable turbocharger apparatus of the present invention may be one in which the bypass aperture is in an insert. Usually, there will be a plurality of the bypass apertures. The vanes may be mounted on the insert. When the variable turbocharger apparatus includes the insert, then the flange may or may not be present as may be desired.

The insert may be a removable insert which is removable from the housing, the removable insert being such that it facilitates assembly of the variable turbocharger apparatus. The removable insert may be a sliding insert.

The removable insert may be held in position by spring means. The spring means may be such that it forms a seal for preventing gas leakage from the chamber which surrounds the turbine. The spring means may be advantageous for manufacture and assembly of the variable turbocharger apparatus in that it reduces tolerance requirements. The spring means may be formed as a heat shield. Alternatively, the spring means may be formed as a disc-shaped spring.

If desired, the insert may be a non-removable insert which is not removable from the housing.

The variable turbocharger apparatus may be one in which the piston passes through a bore in the insert.

Advantageously, the piston has a first abutment for forming a seal against a mating surface thereby to prevent loss of the exhaust gases between the abutment and the mating surface. The mating surface may be a mating surface on a part of the housing. Alternatively, the mating surface may be a mating surface on the insert. The mating surface may also be used to set the start gap of the turbocharger apparatus.

The variable turbocharger apparatus may be one in which the piston has a second abutment for engaging against the end of the vanes, thereby setting the gap when the piston is in its closed position.

The variable turbocharger apparatus may include a sealing ring for forming an auxiliary seal for preventing loss of any of the exhaust gases that pass between the first abutment and the mating surface.

The variable turbocharger apparatus may be one which includes a ring on the piston for setting the size of the gap at a start condition, the ring also being such that it acts as an abutment for preventing gas leakage.

The control means may include a fork member which is connected to the piston on two opposed sides. Alternatively, the control means may include a U-shaped member which is connected to the piston on a face of the piston.

The control means will be an electronic control means which operates as part of an engine management control system. The control system may also use an air or oil operated actuator control means in conjunction with the engine management system.

The variable turbocharger may be one in which the chamber is a volute. Various types of chamber may be employed, for example of various cross sectional shapes.

Embodiments of the invention will now be described solely by way of example and with reference to the accompanying drawings in which:

Figure 1 is a section through first variable turbocharger apparatus with a piston in a closed position;

Figure 2 is a section like Figure 1 but with a piston in a position just before the gases are allowed to bypass;

Figure 3 is a section like Figure 1 but with a piston in a fully open bypass position:

Figure 4 is a section like Figure 3 but shows bypass apertures in side view rather than in section;

Figures 5, 6 and 7 show side and end views of an insert having bypass apertures and vanes, and a bypass area in a bore of the insert;

Figures 8 and 9 are side and end views of a piston with a flange and slots in the flange;

Figure 10 is a side view of a ring member for going over the right hand end of the piston as shown in Figure 8;

Figure 11 is a side view of a piston and shows the mounting of a flange on the end of the piston;

Figure 12 is an end view of a flange part of the piston shown in Figure 11, the flange having slots for vanes;

Figure 13 is an end view of a flange part of the piston shown in Figure 11, flange being an alternative to that shown in Figure 12 and the flange having slots extending inwardly from a periphery of the flange;

Figure 14 is a section through second variable turbocharger apparatus of the present invention;

Figure 15 is a section through part of the third variable turbocharger apparatus of the invention;

Figure 16 is a section through part of fourth variable turbocharger apparatus of the present invention;

Figure 17 is a section through part of fifth variable turbocharger apparatus of the present invention;

Figure 18 is a section through part of sixth variable turbocharger apparatus of the present invention;

Figure 19 is a side section through seventh variable turbocharger apparatus of the present invention;

Figure 20 is a side of variable turbocharger apparatus of the present invention and shows control means; and

Figure 21 is a section through part of eighth variable turbocharger apparatus of the invention.

Referring to Figures 1 - 4, there is shown variable turbocharger apparatus 2 comprising a housing 4 a compressor 6 mounted for rotation in the housing 4, and a turbine 8 which is also mounted for rotation in the housing 4. The variable turbocharger apparatus 2 also comprises a first inlet 10 for enabling air to be conducted to the compressor 6, and an outlet 12 for enabling air from the compressor 6 to be conducted to an engine (not shown).

The variable turbocharger apparatus 2 has a second inlet 14 for enabling exhaust gases from the engine to be conducted to the turbine 8 in order to rotate the turbine 8. A chamber 16 extends around the turbine 8 and receives the exhaust gases from the second inlet 14 before the exhaust gases are conducted to the turbine 8.

A bearing assembly 18 permits the rotation of the turbine 8. A heat shield 20 is provided for shielding the bearing assembly 18 from heat from the exhaust gases.

The variable turbocharger apparatus 2 comprises vanes 22 which are mounted in the chamber 16 and which are for accurately directing the exhaust gases on to the turbine 8. A piston 24 is positioned between the vanes 22 and the turbine 8. The piston 24 is a slideable piston. Control means 26 control the sliding movement of the piston 24.

The piston 24 has an end 28 which is adjacent the heat shield 20. This end 28 is spaced apart from the heat shield by a gap 30. Figure 1 shows the piston 24 in a closed position in which the gap 30 is at its smallest

condition. The size of the gap 30 is variable in dependence upon the sliding of the piston 24, as can be appreciated from Figures 2, 3 and 4. The sliding of the piston 24 is under the general control of the control means 26. The size of the gap 30 is effective to control the amount of the exhaust gases that acts on the turbine 8, thereby accurately controlling the rotational speed of the turbine 8 and thereby the amount of air conducted by the compressor through the outlet 12 to the engine.

The variable turbocharger apparatus 2 also comprises a shaft 32 on which the turbine 8 and the compressor 6 are mounted. The compressor 6 is secured to a reduced diameter end portion 34 of the shaft 32 by a nut 36 which screws on to a screw threaded portion 38 on the end portion 34 of the shaft 32.

The turbine 8 has a central body portion 40 and vanes 42. The compressor 6 has a central body portion 44 and vanes 46.

Compressed air from the compressor 6 passes along a diffuser passage 48 into a chamber 50 in the form of a volute as shown. The chamber 16 feeding the exhaust gases to the turbine 8 is also in the form of a volute as shown.

Bolts 52 bearing on washers 54 secure a back plate 56 to a part of the housing 4 that is for the compressor 6. Bolts 58 go into the bearing assembly 18 to hold the back plate 56 in position.

The bearing assembly 18 has an oil intake 60 for providing oil for the bearing assembly 18. Also provided is an oil drain 62.

Clamp 64 acts on the housing 4 and the bearing assembly 18 to clamp the bearing assembly 18 to the part of the housing 4 that is for the turbine 8.

The piston 24 slides against an insert 96 as shown. The insert can be made of a corrosion resistant material depending upon the material used for the housing 4. The housing 4 can basically be regarded as being a three part housing comprising a turbine housing 4A, a compressor housing 4B, and a bearing housing 4C.

Referring to Figures 1 – 4, the control means 26 has an air intake 70 for controlling an actuator member 72. A diaphragm (not shown) in the actuator member 72 is acted upon by air or a vacuum. The air intake or vacuum is controlled by an electronic control device (not shown). Movement of the diaphragm causes movement of rod 27, and movement of piston 24 that is connected to the rod 27 by arms 29 of the piston 24.

An alternative control means is shown in Figures 19 and 20. The control means 26 has an air intake 70 for controlling an actuator 72. A diaphragm (not shown) in the actuator member 72 is acted upon by air or a vacuum. The air intake is controlled by an electronic control device (not shown). Movement of the diaphragm causes movement of an arm 74. The arm 74 pivots a rod 76 (see Figure 20). The rod 76 as best shown in Figure 20, is connected to a fork device 78 having a pair of arms 80, 82. Each arm 80, 82 has a locator member 84. Each location member 84 locates in a recess 86 as shown in Figure 19.

As can be seen from Figures 1 - 4, the vanes 22 are mounted on the insert 96. In an alternative embodiment of the invention, the vanes 22 may be mounted on the heat shield 20.

The piston 24 has an abutment 88 for forming a seal against a mating abutment 105, thereby to prevent loss of the exhaust gases between the abutment 88 and the abutment 105. The abutment 105 is formed as a part of the insert 96.

The provision of the abutment 88 and the mating surface 105 may be sufficient to prevent the loss of the exhaust gases between the abutment 88 and the mating surface 105. As an extra precaution against the loss of the exhaust gases, a seal 94 is provided. In Figure 14, the seal 94 is provided in a piston 24 in a part of the housing 4. The seal 94 is in the form of a sealing ring and it thus acts to form an auxiliary seal for preventing loss of any of the exhaust gases that might pass between the abutment 88 and the mating surface 105.

The end 28 of the piston 24 has a flange 109. The flange 109 extends radially outwardly as shown. The flange 109 is provided with slots (not shown in Figure 1) for receiving the vanes 22.

The heat shield 20 shown in Figure 1 is a disc-shaped heat shield which is of a floating type of design, and which has an outer ring portion 93 and an inner wall portion 95. The inner wall portion 95 has an aperture 97 through which the turbine 8 passes.

Figure 1 shows the heat shield pushed against the bearing assembly 18, in order to seal the back face of the heat shield so that an air cooling system may be used, or to seal between the heat shield and bearing assembly as shown in Figure 21.

Figure 1 shows the variable turbocharger apparatus 2 with the gap 30 at a minimum. In this position, bypass apertures 99 in the insert 96 are closed by a ring member 101 which is secured over the piston 24 as shown such that it abuts against an abutment 103 and becomes part of piston 24. The ring member 101 abuts against an abutment 105 on the insert 96. This effectively limits the movement of the piston 24 to the left as shown in Figure 1 and thus sets the minimum size of the gap 30.

Figure 2 shows the piston 24 having moved towards the right as shown in Figure 2 in order to increase the size of the gap 30. In the position of the piston 24 shown in Figure 2, the bypass apertures 99 are still closed by the ring member 101.

Figure 3 shows the piston 24 having moved further still to the right as shown in Figure 2. In the position of the piston 24 shown in Figure 3, the bypass apertures 99 have been uncovered by the ring member 101. Figure 4 shows the bypass apertures 99 from the outside rather than in cross section as in Figure 3. During operation of the turbocharger apparatus 2, the bypass apertures 99 open when the gap 30 reaches a predetermined size. The opening of the bypass apertures 99 is such as to allow exhaust gases that are not required for acting on the turbine 8 to bypass the turbine

8. In Figures 1 – 4, the gases that act on the turbine 8 are shown by directional lines having a single arrowhead. In Figures 3 and 4, the gases that bypass the turbine 8 are shown by directional arrows with two arrowheads. As can be seen from Figures 3 and 4, the exhaust gases in the chamber 16 around the turbine 8 flow in two directions at the same time. Thus exhaust gases are able to act at the required pressure on the turbine 8, and exhaust gases that are not required are able to bypass the turbine 8. This avoids the situation where otherwise, all the gases in the chamber 16 would act on the turbine 8 at too greater pressure and would cause the turbine 8 to revolve too fast and destroy the turbocharger apparatus 2 when a smaller turbine housing was used to improve low down response. The use of the bypass apertures 99 also avoids the alternative which is currently employed of having two separate exhaust gas control systems, one being for controlling the gases onto the turbine, and the other being for controlling the gases through a waste gate system when the pressure is too high. Self-evidently, two separate control systems double costs, in addition to providing more components for potential wear and failure.

Figures 5, 6 and 7 show the insert 96. In particular, Figures 5, 6 and 7 show the position of the vanes 22 on the insert 96, and also the shape of the bypass apertures 99. The bypass apertures 99 are triangularly shaped as shown. The bypass apertures are progressively opened to increase their volume. This provides a controlled opening of the bypass apertures 99 and avoids fluctuations in operation of the turbocharger apparatus 2 which might

otherwise occur due to a too sudden opening of the bypass apertures 99 and a consequent too sudden loss of exhaust gas pressure in the chamber 16.

Figure 8, 9 and 10 illustrate how the piston 24 is provided with three arms 29 for connecting the piston 24 to a shaft 27 which connects to an actuator member 72 forming part of control means for the variable turbocharger apparatus 2.

Figures 11 and 12 show a piston 107 having a flange 109. Slots 111 are provided in the flange 109 and the slots 111 are closed ended slots. Also shown in Figure 11 is how the flange 109 may be fixed to the end of the piston 107.

Figure 13 shows the flange 109 provided with alternative slots 118 which are open at the periphery of the flange 109 as shown in Figure 13.

Figure 14 shows second variable turbocharger apparatus 115 which is like the variable turbocharger apparatus 2 but which has an insert 117 which screws into a part of the housing 4 by screw threads 119. In Figure 14, the vanes 22 are short vanes and they are mounted on the heat shield 20. The flange 91 of the piston 24 does not have any slots for the vanes.

Figure 15 is a section through part of third variable turbocharger apparatus 115A and shows vanes going across a volute entry passage. The vanes do not go through slots in the flange.

Figure 16 shows part of fourth variable turbocharger apparatus 121 in which a disc spring 123 is used to push the insert 96 to the right as shown in

Figure 16 in order to seal the insert 96 in the turbine housing 4. The disc spring 123 is also able to be used as a heat shield.

Figure 17 shows part of variable turbocharger apparatus 125 utilising a disc spring 127 and a heat shield 129. The heat shield 129 is pushed over by the disc spring 127. The heat shield 129 pushes the vanes 22 over to seal in the insert 96 in the housing 4, and also to prevent rotation of the insert 96. With the disc spring 127 between the heat shield 129 and the bearing housing 18, the disc spring 127 may be used to seal the back of the heat shield 129, and the heat shield 129 helps to prevent heat adversely affecting the disc spring 127. The turbocharger 125 as shown in Figure 17 is of a design that also allows for a good flow of the exhaust gases, because the heat shield 129 is flush against ends of the vanes 22.

Figure 18 shows part of variable turbocharger apparatus 131 in which a heat shield 133 is used as a spring to push the insert 96 to the right as shown in Figure 18 in order to seal in the turbine housing 4. The heat shield 133 is fixed at its outer periphery 135 as shown, and at its inner periphery 137 as shown. The inner periphery 137 of the heat shield 133 forms an inner ring that may be used to seat against the bearing housing as shown in Figure 18, in order to push the heat shield 133 over against the vanes 22.

Figure 19 is a section through seventh variable turbocharger apparatus 139. Figure 19 shows a control system using a fork to move and control the movement of the piston 24.

Figure 20 shows an end view of the turbocharger apparatus of the present invention, for example as shown in Figure 19, and illustrates in more detail the location of the fork member 78.

Figure 21 shows variable turbocharger apparatus having a floating heat shield 150 that seals under spring pressure from a spring 177. Also shown in Figure 21 is a cooling system 152 which is formed between the heat shield 150 and the bearing housing 18.

The variable turbocharger apparatus of the present invention and shown in the accompanying drawings is able to work efficiently and to be manufactured economically. The gap 30 is able to be varied by the sliding piston 24. Where a flange on the end of the piston is employed, then the flange forms a control ring that slides over the vanes. By using the flange, the exhaust gases are guided more accurately through the vanes onto the turbine. Thus, the performance of the variable turbocharger apparatus is enhanced. Pressure on the back face of the flange helps to keep the piston in a closed position, so that a smaller sized control means may be used. Gas leakage through the slots where the vanes are located is not a problem with the variable turbocharger apparatus of the present invention because gas pressure is the same both sides of the control ring. During use of the variable turbocharger apparatus, if a carbon deposit builds up on the vanes, then this is cleaned off as the flange of the piston moves backwards and forwards over the vanes, with the vanes passing through the slots in the flange. Gas leakage is prevented when the piston is in its closed position.

When the piston is in its closed position, this is the most vulnerable time for gas leakage. However, with the variable turbocharger apparatus of the present invention, all the gases are guided accurately through the vanes, the heat shield and the flange in order to work on the turbine as required.

With the turbocharger apparatus of the present invention, the turbocharger apparatus is able to allow a smaller volume turbine housing to be used. This in turn gives a better low down response of the turbine.

The turbocharger apparatus of the present invention is able to guide the gases onto the turbine through the vanes on the insert, and the flange on the piston, this gives good performance of the turbine.

The insert may be held in place by a spring in order to seal the insert from gas leakage. The spring also prevents rotation of the vanes and the insert. This is also a quick and cheap form of production. With this design, the vanes may be pushed against the heat shield to give a good gas flow.

The bypass apertures in the insert allow the gases to bypass the turbine in order to lower the pressure in the volute area of the turbine housing when the gap opens past a predetermined position. Any suitable and appropriate predetermined position may be utilised, depending upon the type of engine to which the turbocharger apparatus is fitted.

The control of the piston 24 to control the variable part of the turbocharger apparatus, and the bypass apertures all form one control unit. This gives lower manufacturing costs than having to use two separate control units.

The bypass apertures 99 are designed triangular as shown in order to prevent a large pressure drop when the system opens up the bypass apertures 99. This prevents turbine wheel surge as mentioned above. An alternative to the bypass apertures 99 being triangularly shaped as shown is to have the slots of any other suitable and appropriate formation, for example of a radius gap shape.

The flange 91 or 109 on the piston 24 allows the gases to be guided through the turbine to give good performance. The flange 91 or 109 also allows the gases to enter past the backface of the flange so as to allow the gases to enter into an area between the piston 24 and bore where the piston 24 works, so as to allow the gases to bypass through the bypass apertures 99.

When the piston 24 is in its closed position, the piston 24 may rest against the abutment 105 in the insert 96 as shown in Figure 1, in order to prevent gas leakage and also to set the start gap of the piston 24. This design prevents all gas leakage when the piston is in its closed position. This is the most difficult part of a variable turbocharger in which to achieve good turbine performance. This is because the gas flow is at its lowest so that it is important to prevent gas leakage.

Sealing means may be used to prevent gas leakage when the variable part of the turbocharger apparatus is working if required. Different control systems for the piston may be used so that, for example, a fork system may be used.

A disc spring may be used to hold the insert 96 and to prevent gas leakage. The disc spring may also be used as a heat shield for the bearing assembly. The disc spring may be used so as to push a heat shield and thereby put pressure on the vanes of an insert in order to hold the insert in place and prevent gas leakage. The disc spring may also seal in order to prevent gas leakage between the heat shield and the bearing assembly. With this design, the vane ends are able to be held flush against the heat shield in order to give good gas flow to the turbine. Also, there are less hot gases working on the spring.

If desired, the insert 117 may be screwed into the turbine housing.

If desired, the disc spring 177 may be used to push the vanes of the insert 96 onto the heat shield, see Figure 1. The disc spring 177 may be used as a seal to prevent gas leakage. This design pushes the vanes 22 flush against the heat shield 20. Also, a small disc spring may be used because the spring works with the spring in the actuator rather than against it.

It is to be appreciated that the embodiments of the invention described above with reference to the accompanying drawings have been given by way of example only and that modifications may be effected. Thus, for example, the shape of the chambers 16 and 50 may be varied. Also, the number of vanes may vary, and the sealing rings may be used or not used as may be desired. As can be seen from the drawings, the variable turbocharger apparatus of the invention is preferably one in which the piston slides between the vanes and the turbine.

CLAIMS

1. Variable turbocharger apparatus comprising a housing, a compressor mounted for rotation in the housing, a turbine mounted for rotation in the housing, a first inlet for enabling air to be conducted to the compressor, an outlet for enabling air from the compressor to be conducted to an engine, a second inlet for enabling exhaust gases from the engine to be conducted to the turbine in order to rotate the turbine, a chamber which surrounds the turbine and which receives the exhaust gases from the second inlet before the exhaust gases are conducted to the turbine, and a bearing assembly for permitting the rotation of the turbine, the variable turbocharger apparatus comprising vanes which are mounted in the chamber and which are for accurately directing exhaust gases on to the turbine, a piston which is slidable and which is positioned between the housing and the turbine, and control means which is connected to the piston and which is for controlling the sliding movement of the piston, the piston having an end which is nearest the bearing assembly and which defines a gap, the size of the gap being variable in dependence upon the sliding of the piston under the control of the control means, the size of the gap being effective to control the amount of the exhaust gases that act on the turbine thereby accurately controlling the speed of rotation of the turbine and thereby the amount of air conducted by the compressor through the outlet to the engine, and the variable turbocharger apparatus having at least one bypass aperture which

is closed when the size of the gap is at a minimum and which opens when the gap reaches a predetermined size, the opening of the bypass aperture being such as to allow exhaust gases that are not required for acting on the turbine to bypass the turbine.

2. Variable turbocharger apparatus according to claim 1 in which the end of the piston is such that it has a flange which extends radially outwardly.

3. Variable turbocharger apparatus according to claim 2 in which the flange has slots for receiving the vanes.

4. Variable turbocharger apparatus according to claim 3 in which the slots are open slots which extend inwardly from the periphery of the flange, or closed slots in the flange.

5. Variable turbocharger apparatus according to any one of claims 2 – 4 in which the flange is such as to allow gases to bypass a back face of the flange whilst still allowing accurate gas flow onto the turbine.

6. Variable turbocharger apparatus according to any one of the preceding claims and including a heat shield for shielding the bearing assembly from heat from the exhaust gases.

7. Variable turbocharger apparatus according to claim 6 in which the heat shield is a ring-shaped heat shield.
8. Variable turbocharger apparatus according to claim 6 in which the heat shield is a disc-shaped heat shield having an outer ring portion, an inner wall portion, and an aperture through the inner wall portion.
9. Variable turbocharger apparatus according to any one of claims 6 - 8 in which the heat shield is a floating heat shield that is held in place under pressure by spring means.
10. Variable turbocharger apparatus according to any one of claims 6 - 9 in which the vanes are mounted on the heat shield.
11. Variable turbocharger apparatus according to any one of the preceding claims in which the bypass aperture is of a V-shape in order that gases are able to bypass in a controlled manner in order to prevent turbine surging.
12. Variable turbocharger apparatus according to any one of the preceding claims in which the bypass aperture is in an insert.

13. Variable turbocharger apparatus according to claim 12 in which there is a plurality of the bypass apertures.
14. Variable turbocharger apparatus according to claim 12 or claim 13 in which the vanes are mounted on the insert.
15. Variable turbocharger apparatus according to claim 14 in which the insert is a removable insert which is removable from the housing, the removable insert being such that it facilitates assembly of the variable turbocharger apparatus.
16. Variable turbocharger apparatus according to claim 15 in which the removable insert is a slidable insert.
17. Variable turbocharger apparatus according to claim 15 or claim 16 in which the insert is held in position by spring means.
18. Variable turbocharger apparatus according to claim 17 in which the spring is such that it forms a seal for preventing gas leakage from the chamber which surrounds the turbine.
19. Variable turbocharger apparatus according to claim 14 in which the insert is a non-removable insert which is not removable from the housing.

20. Variable turbocharger apparatus according to any one of claims 15 – 19 in which the piston passes through a bore in the insert.
21. Variable turbocharger apparatus according to any one of the preceding claims in which the piston has a first abutment for forming a seal against a mating surface thereby to prevent loss of the exhaust gases between the abutment and the mating surface.
22. Variable turbocharger apparatus according to claim 21 in which the mating surface is a mating surface on a part of the housing.
23. Variable turbocharger apparatus according to claims 9 and 21 in which the mating surface is a mating surface on the insert.
24. Variable turbocharger apparatus according to any one of claims 21 – 23 in which the piston has a second abutment for engaging against the end of the vanes, thereby setting the gap when the piston is in its closed position.
25. Variable turbocharger apparatus according to any one of claims 21 – 24 and including a sealing ring for forming an auxiliary seal for preventing

loss of any of the exhaust gases that pass between the first abutment and the mating surface.

26. Variable turbocharger apparatus according to any one of claims 1 – 20 and including a ring on the piston for setting the size of the gap at a start condition, the ring also being such that it acts as an abutment for preventing gas leakage.

27. Variable turbocharger apparatus according to any one of the preceding claims in which the control means includes a fork member, which is connected to the piston on two opposed sides.

28. Variable turbocharger apparatus according to any one of claims 1 - 25 which the control means includes a U-shaped member which is connected to a face of the piston.

29. Variable turbocharger apparatus according to any one of the preceding claims in which the control means is an electronic control means which operates as part of an engine management control system.

30. Variable turbocharger apparatus according to any one of the preceding claims in which the chamber is a volute.

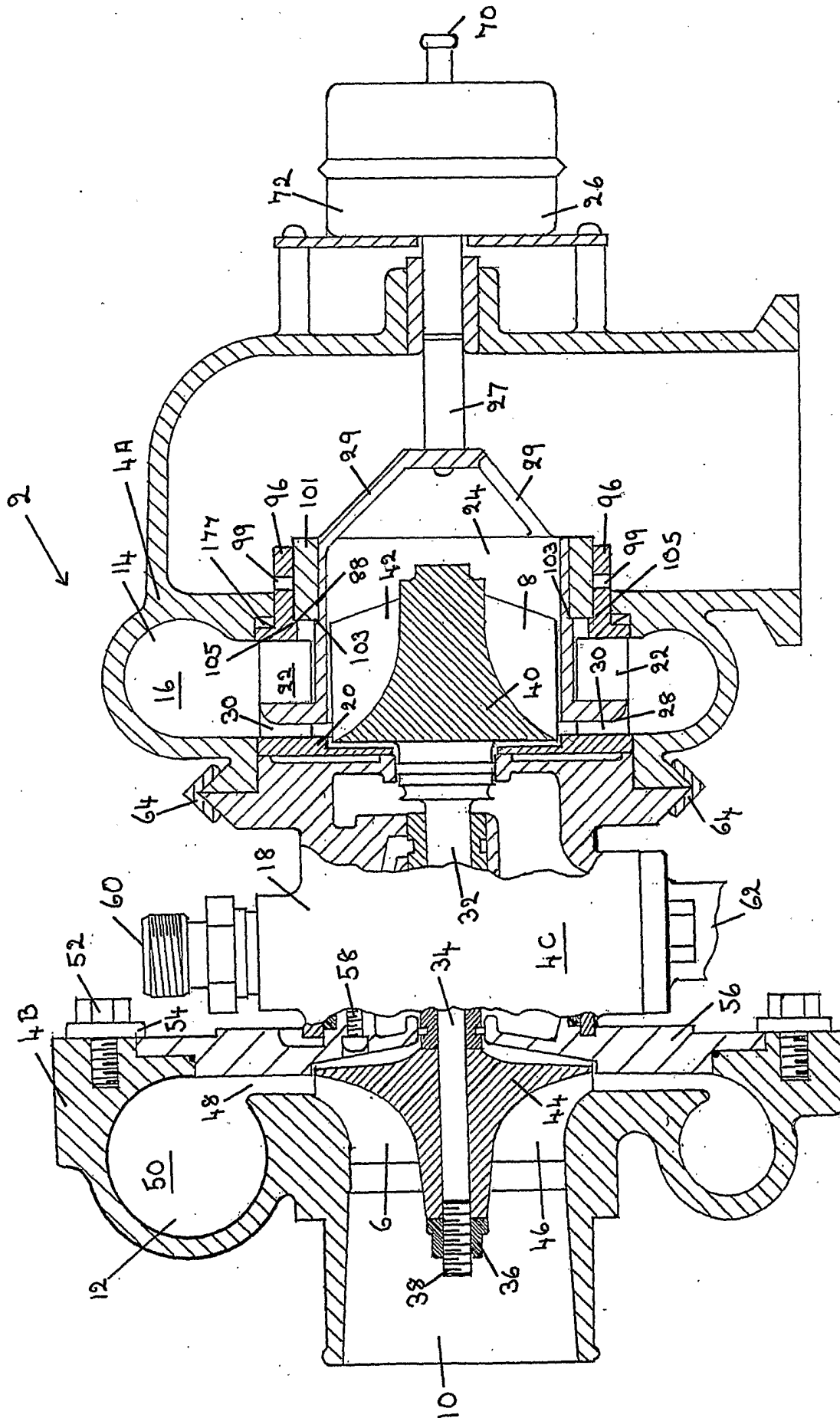

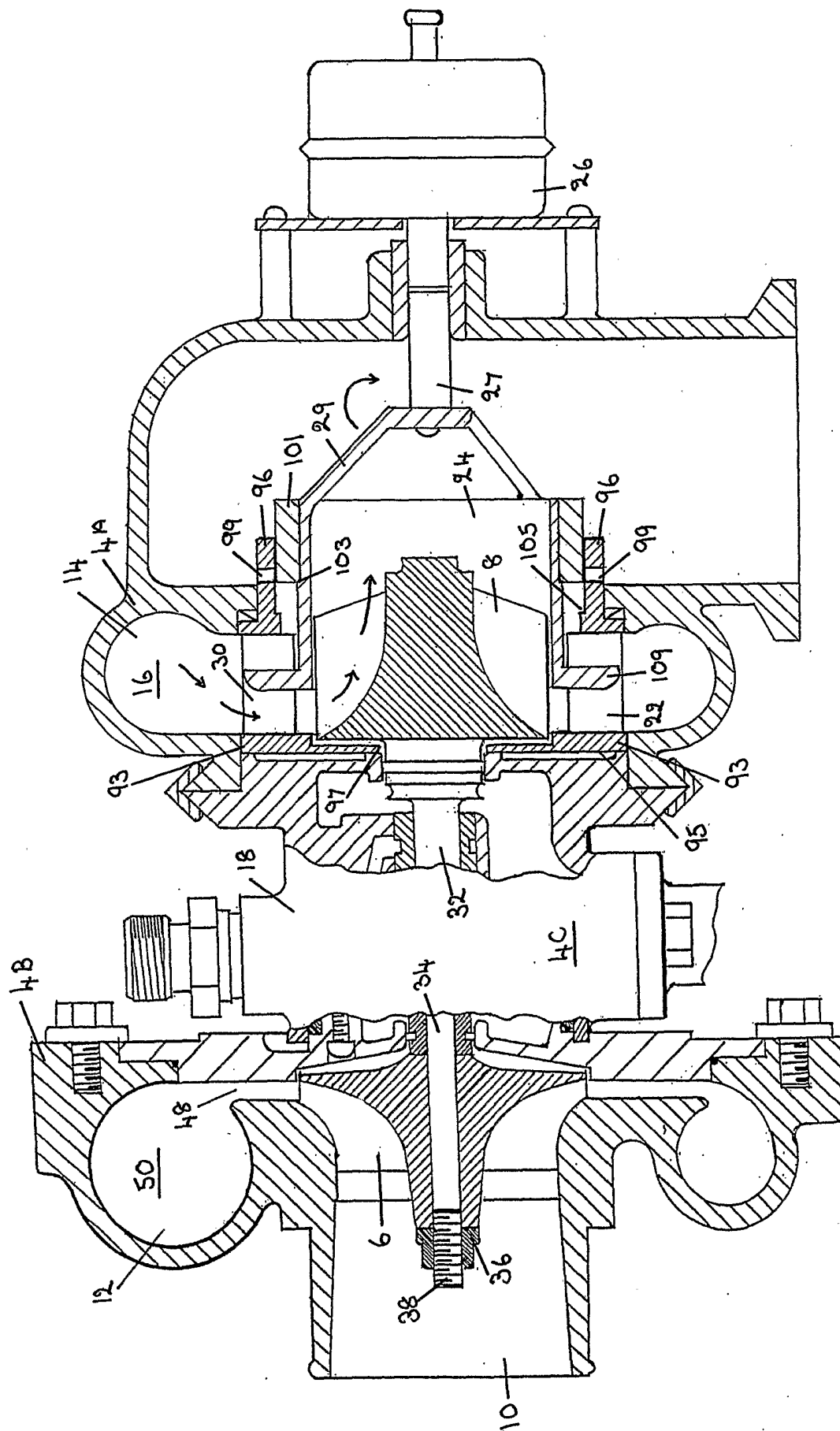

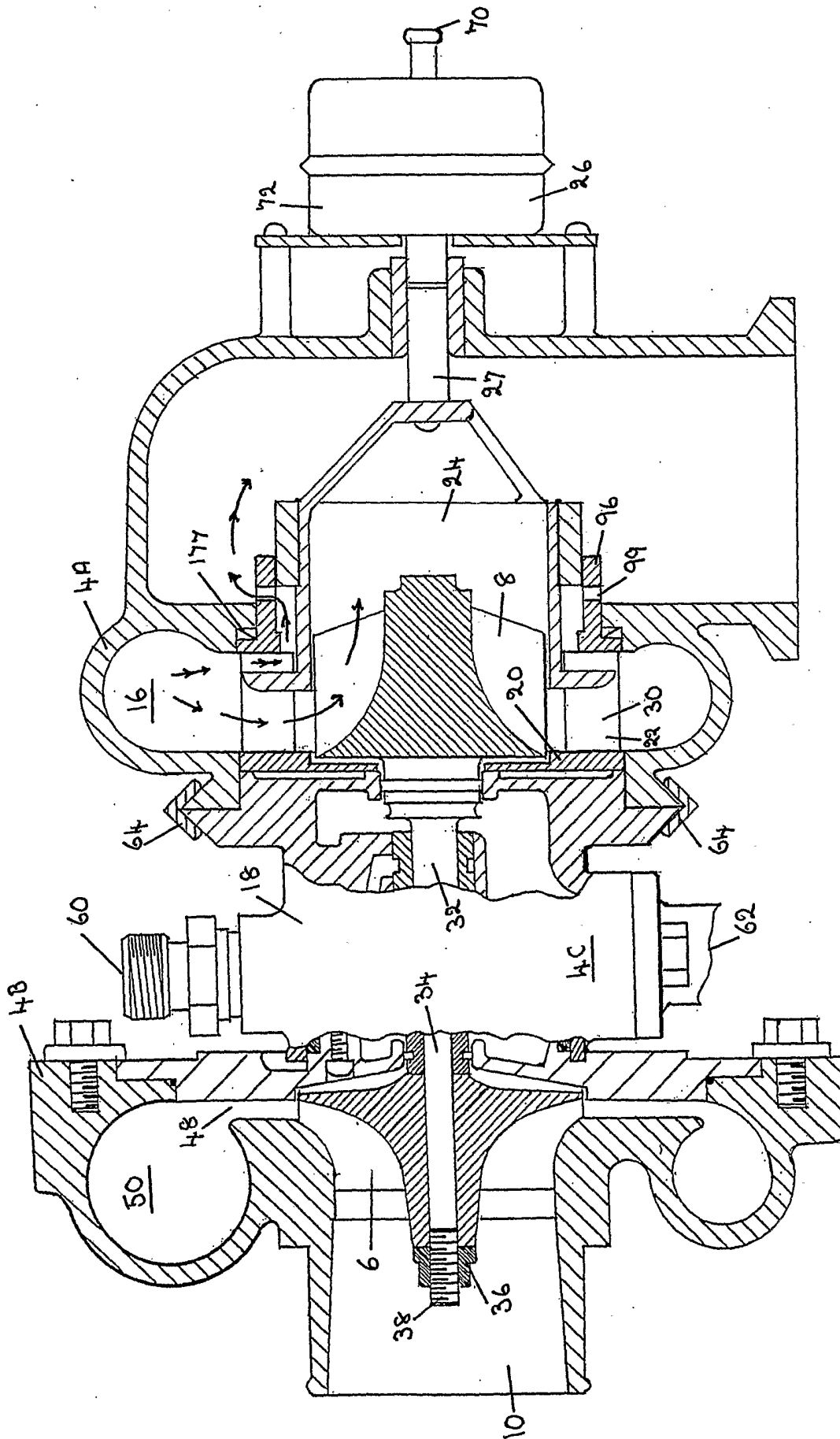

FIG 3

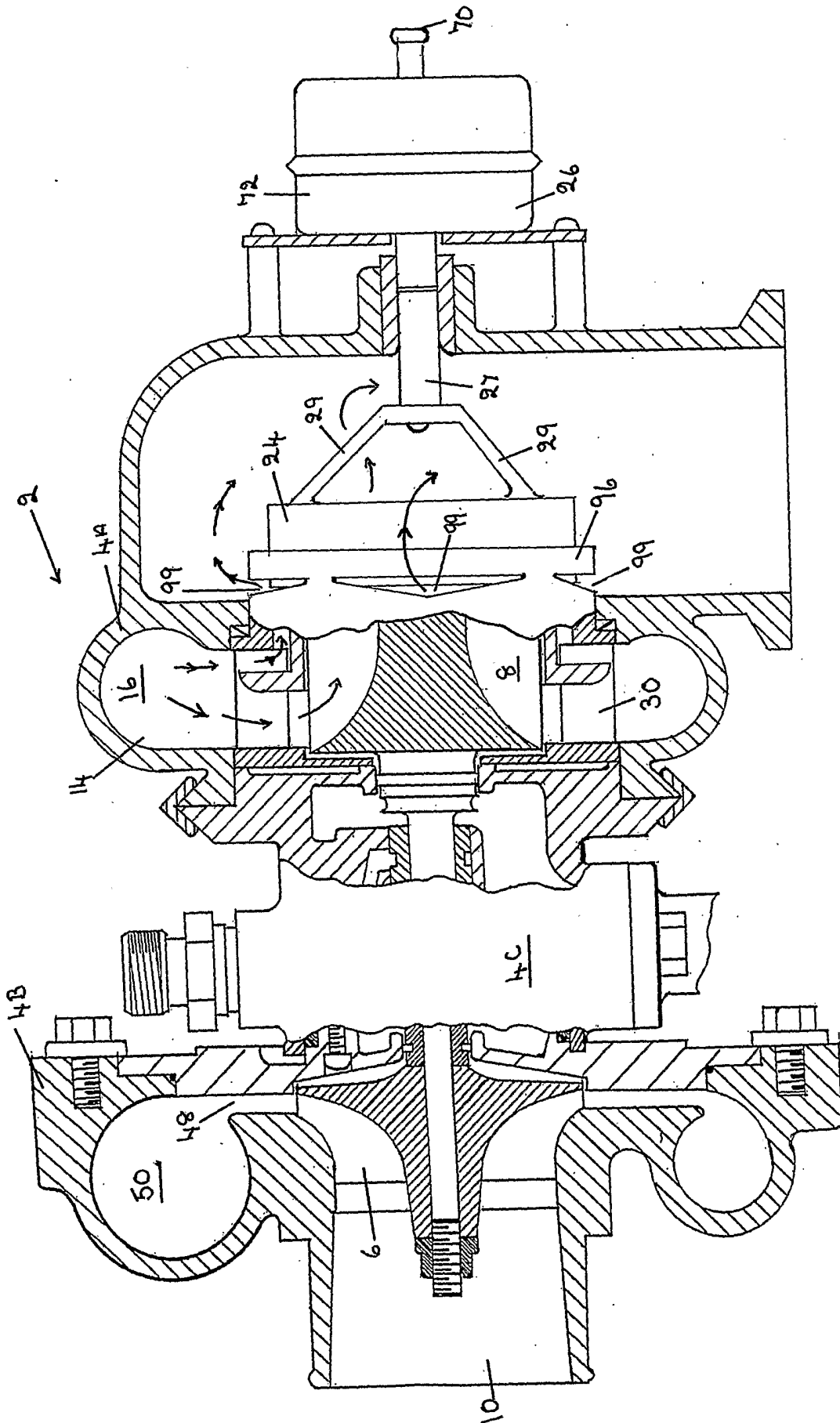

FIG 4

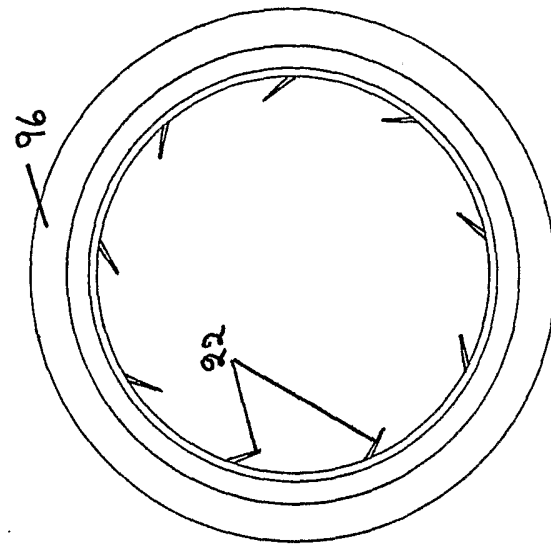

Fig 7

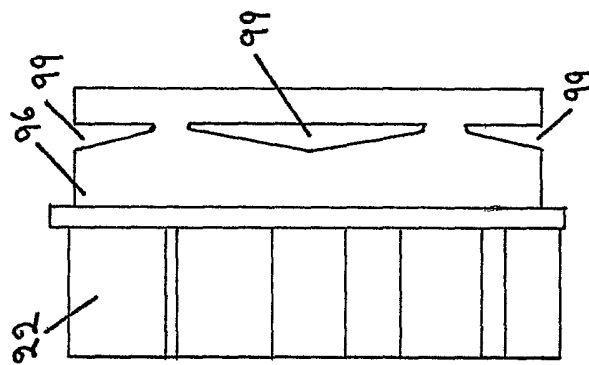

Fig 5

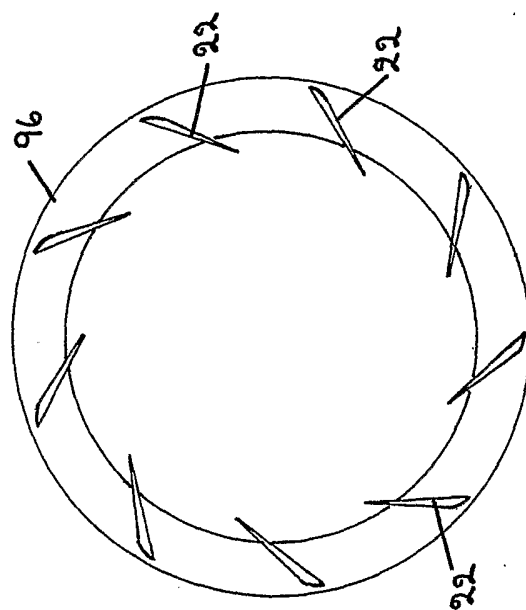

Fig 6

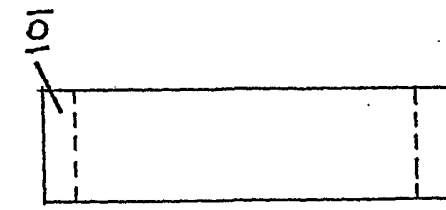

FIG 10

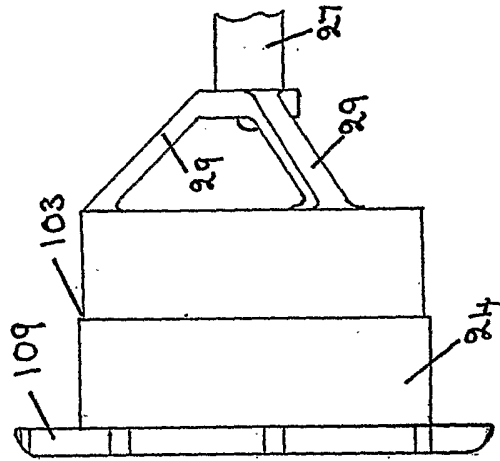

FIG 8

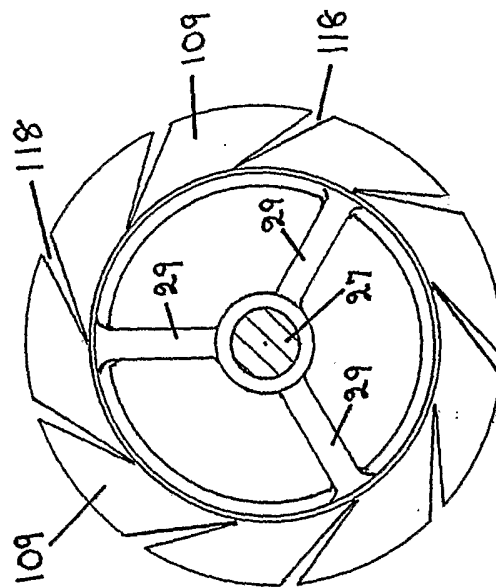

FIG 9

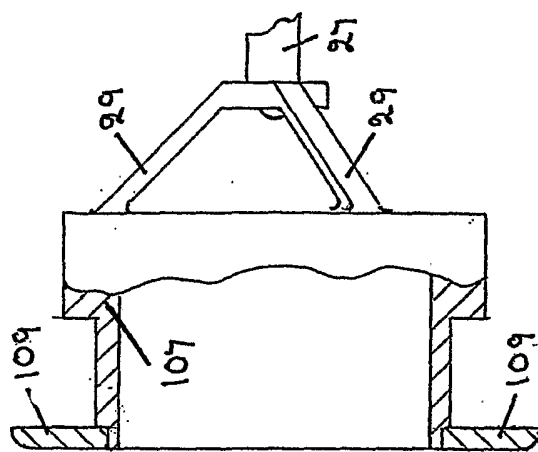

FIG 11

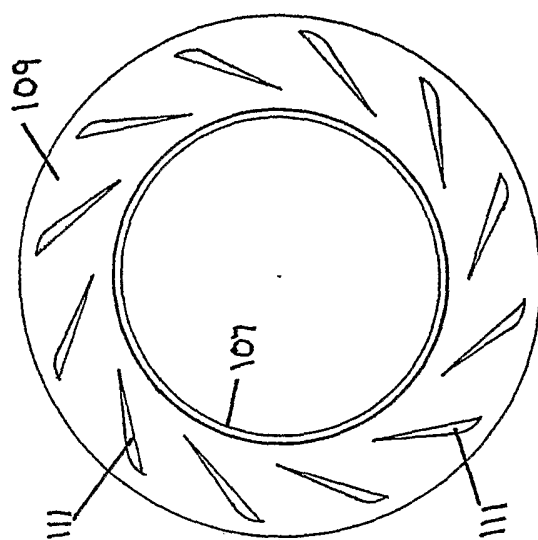

FIG 12

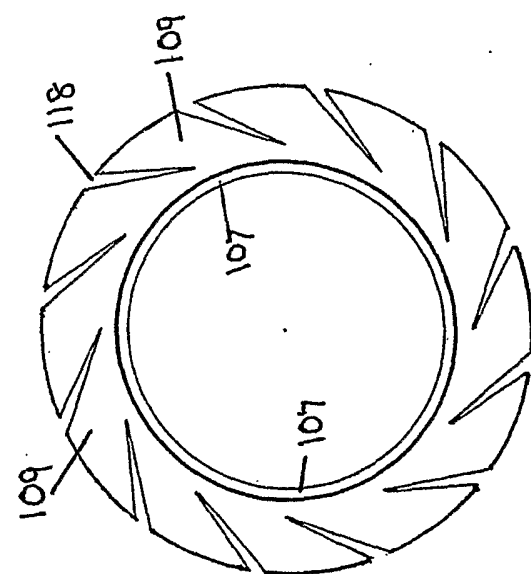

FIG 13

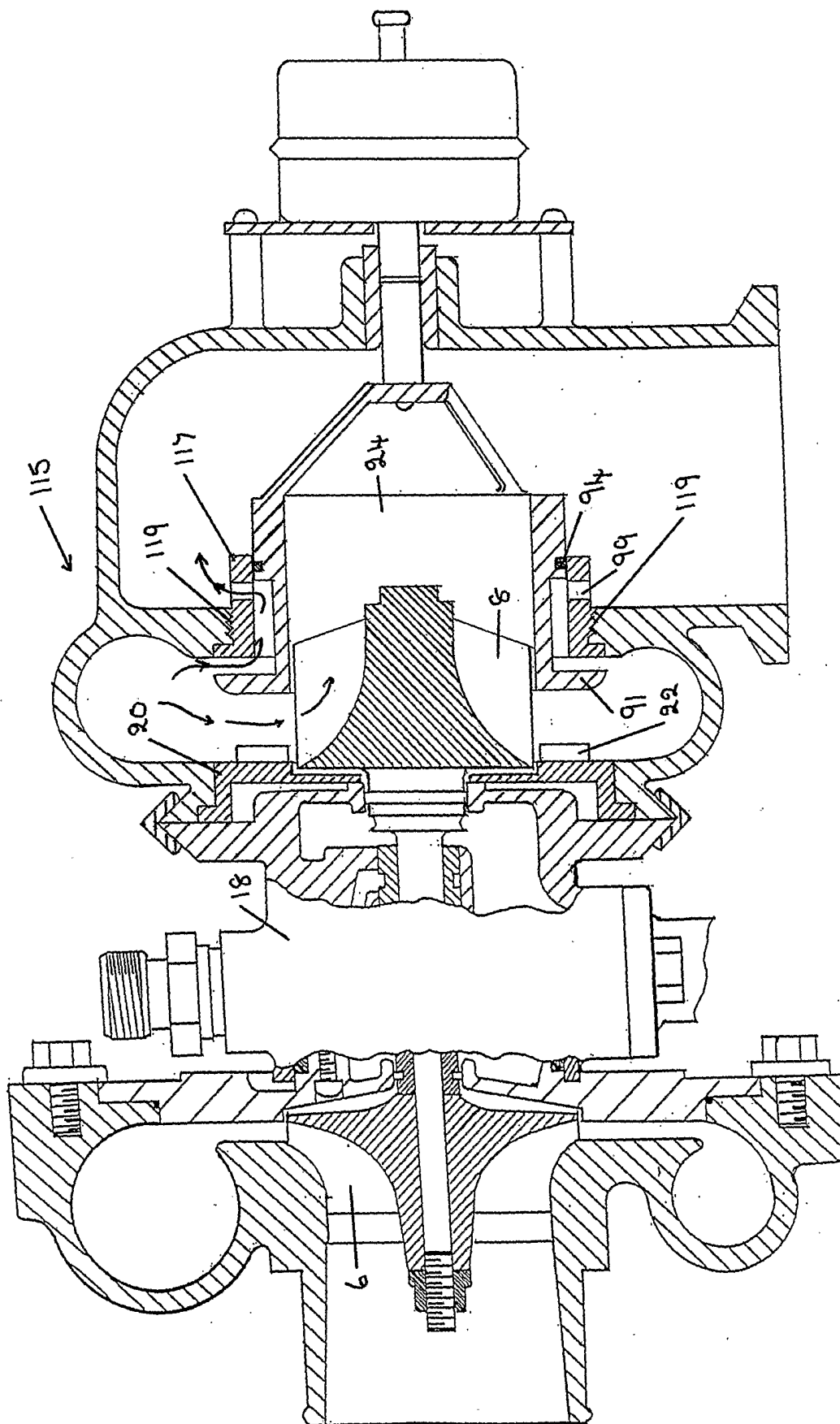

FIG 14.

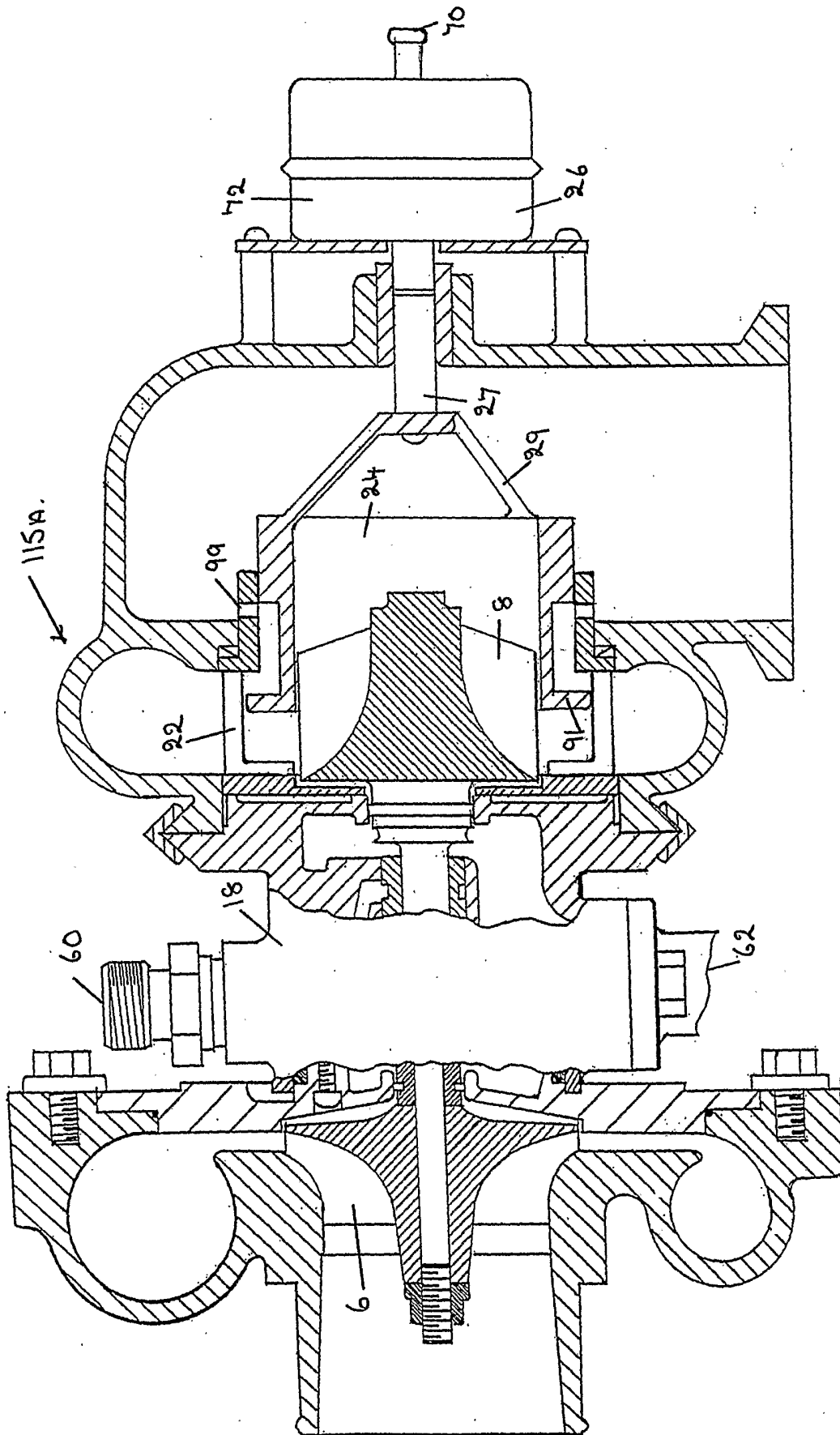

FIG 15

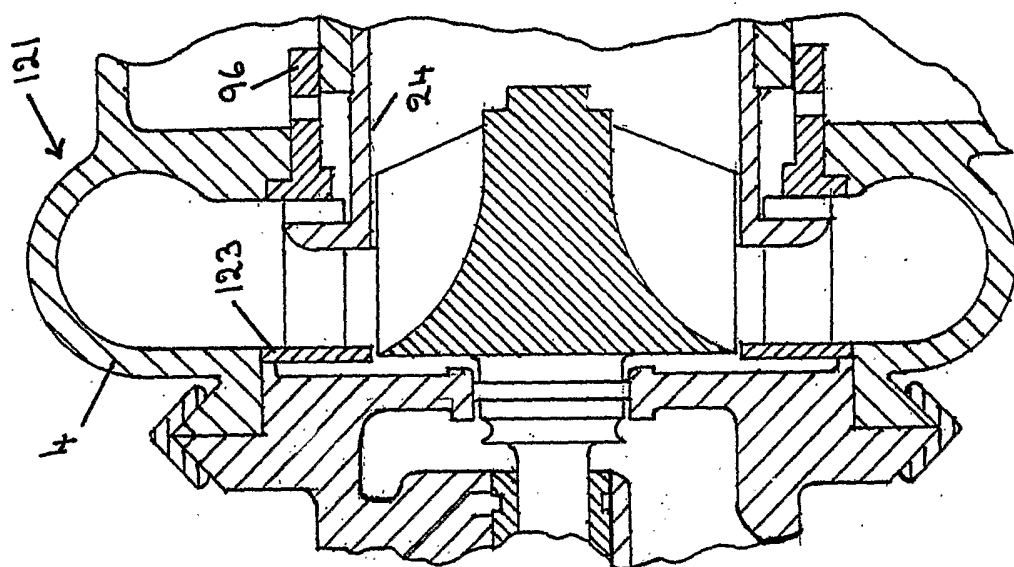

FIG 16

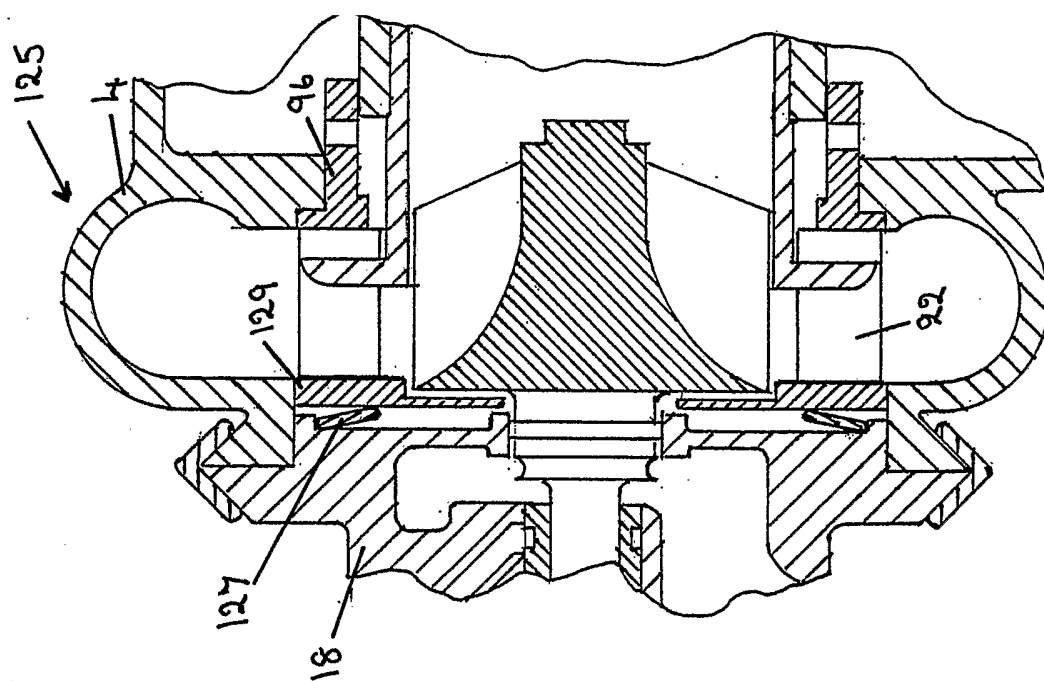

FIG 17

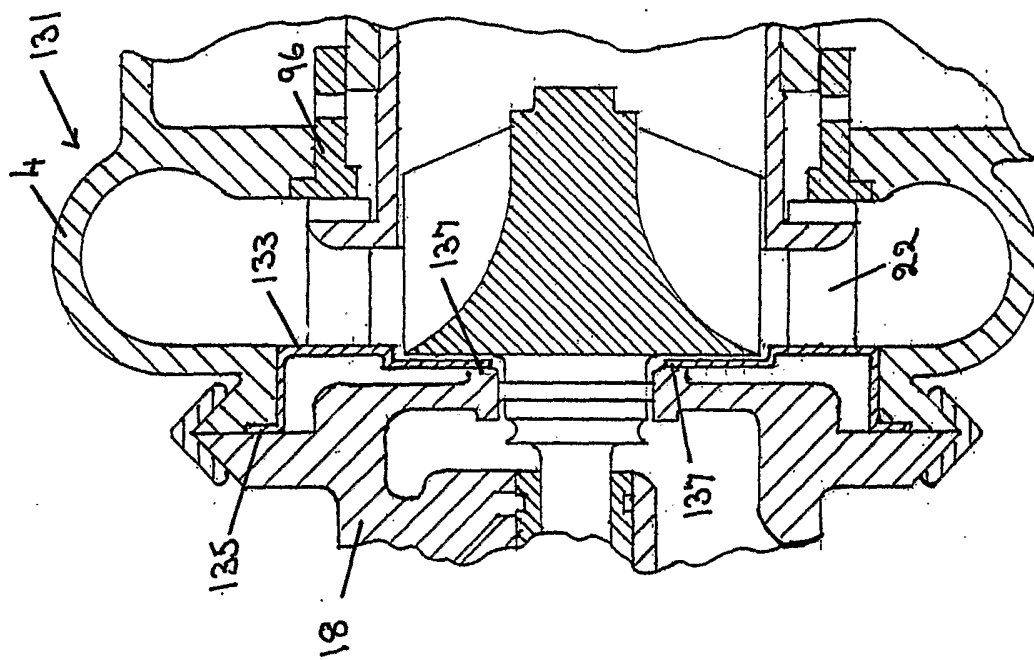

FIG 18

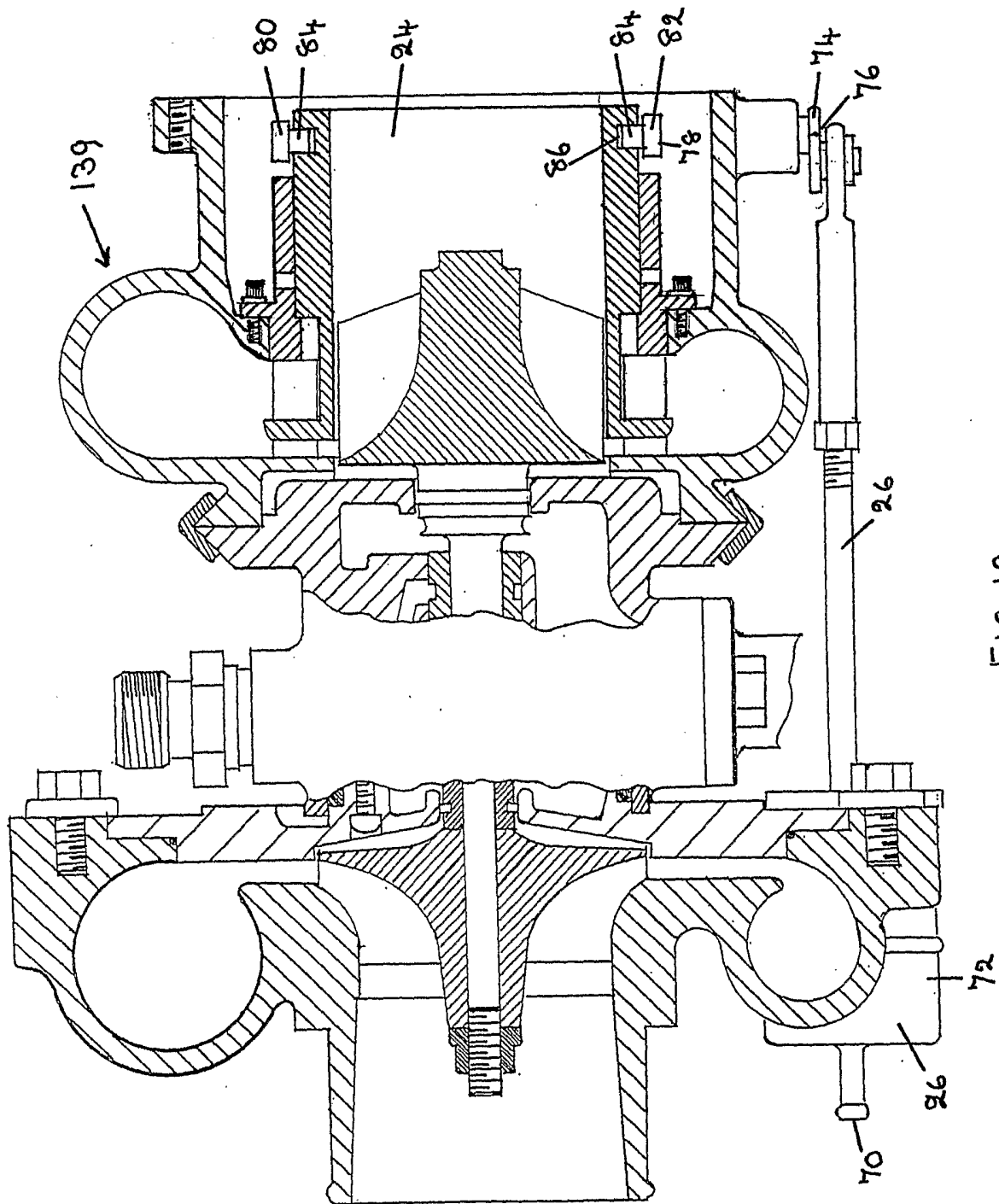

FIG 19.

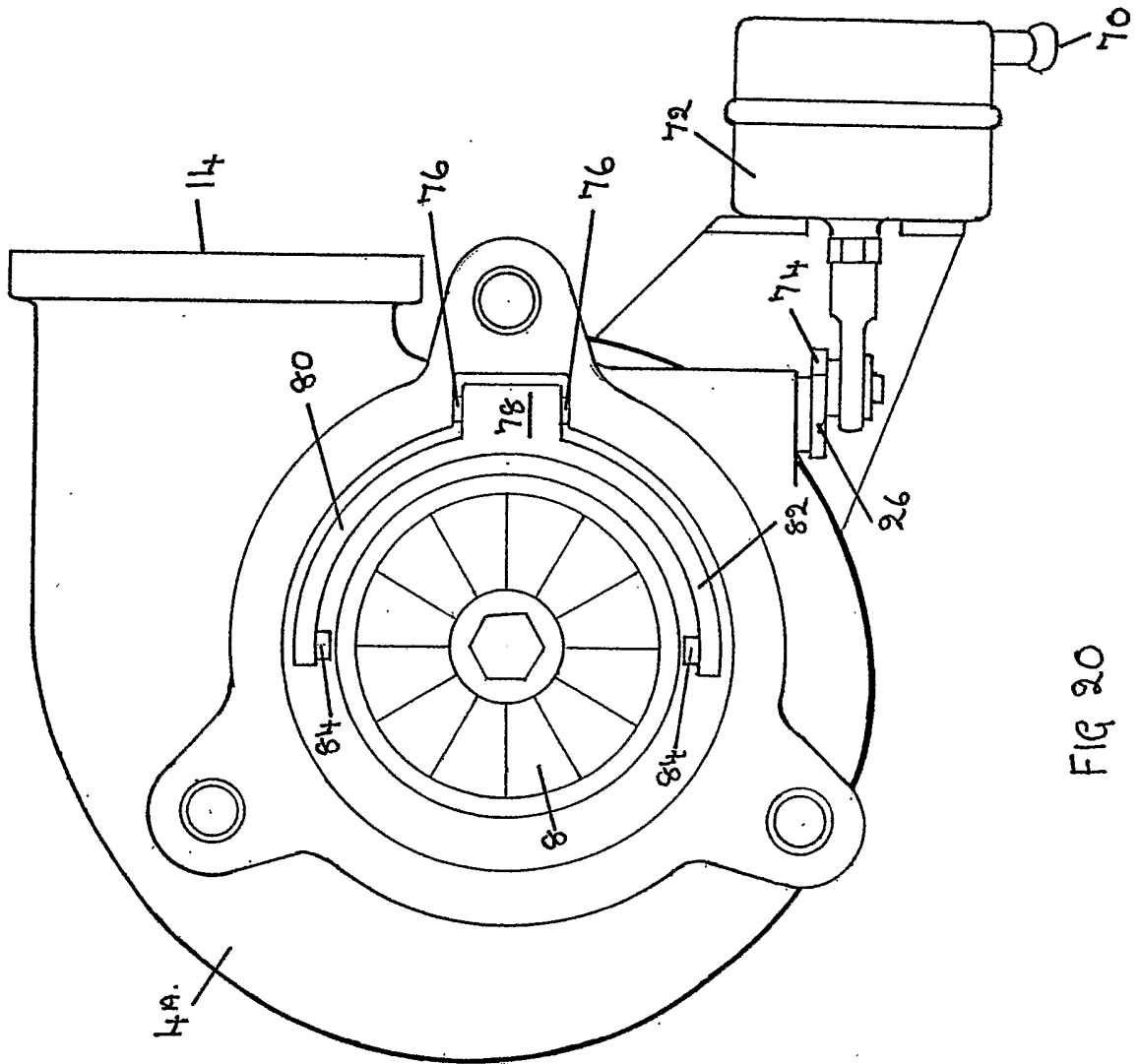

FIG 20

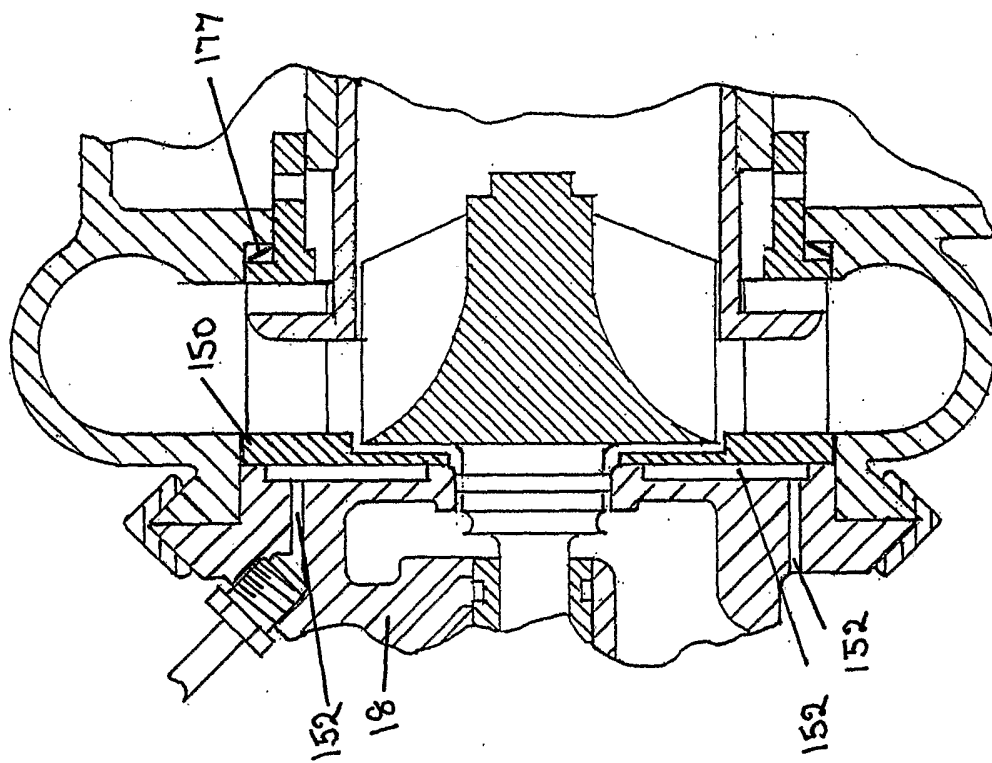

FIG 21

INTERNATIONAL SEARCH REPORT

Internat	Application No
PCT/...	03/04961

A. CLASSIFICATION OF SUBJECT MATTER
 IPC 7 F01D17/10 F01D17/14

According to International Patent Classification (IPC) or to both national classification and IPC

B. FIELDS SEARCHED

Minimum documentation searched (classification system followed by classification symbols)
 IPC 7 F02C F01D

Documentation searched other than minimum documentation to the extent that such documents are included in the fields searched

Electronic data base consulted during the international search (name of data base and, where practical, search terms used)

EPO-Internal

C. DOCUMENTS CONSIDERED TO BE RELEVANT

Category °	Citation of document, with indication, where appropriate, of the relevant passages	Relevant to claim No.
X Y	US 5 855 117 A (SCHADE MARCO ET AL) 5 January 1999 (1999-01-05) abstract; figures column 2, line 10 - line 24 column 3, line 31 -column 4, line 34 ---	1,12,30 2-8,10, 21-29
X	DE 199 24 228 A (3K WARNER TURBOSYSTEMS GMBH) 7 December 2000 (2000-12-07) abstract; figures ---	1,2,6,8, 21,22, 25,30
Y A	EP 0 678 657 A (LEAVESLEY MALCOLM GEORGE) 25 October 1995 (1995-10-25) abstract; claims; figures 7-20 column 2, line 46 -column 3, line 35 --- -/--	6,8,29 30

Further documents are listed in the continuation of box C.

Patent family members are listed in annex.

° Special categories of cited documents :

- *A* document defining the general state of the art which is not considered to be of particular relevance
- *E* earlier document but published on or after the international filing date
- *L* document which may throw doubts on priority claim(s) or which is cited to establish the publication date of another citation or other special reason (as specified)
- *O* document referring to an oral disclosure, use, exhibition or other means
- *P* document published prior to the international filing date but later than the priority date claimed

- *T* later document published after the international filing date or priority date and not in conflict with the application but cited to understand the principle or theory underlying the invention
- *X* document of particular relevance; the claimed invention cannot be considered novel or cannot be considered to involve an inventive step when the document is taken alone
- *Y* document of particular relevance; the claimed invention cannot be considered to involve an inventive step when the document is combined with one or more other such documents, such combination being obvious to a person skilled in the art.
- *&* document member of the same patent family

Date of the actual completion of the international search

2 March 2004

Date of mailing of the international search report

08/03/2004

Name and mailing address of the ISA

European Patent Office, P.B. 5818 Patentlaan 2
 NL - 2280 HV Rijswijk
 Tel. (+31-70) 340-2040, Tx. 31 651 epo nl,
 Fax: (+31-70) 340-3016

Authorized officer

de Rooij, M

INTERNATIONAL SEARCH REPORT

Internat. Application No.
PCT/GB J3/04961

C.(Continuation) DOCUMENTS CONSIDERED TO BE RELEVANT		
Category *	Citation of document, with indication, where appropriate, of the relevant passages	Relevant to claim No.
Y	GB 2 271 814 A (LEAVESLEY MALCOLM GEORGE) 27 April 1994 (1994-04-27)	27
A	abstract; figures 1-3 page 5, line 1 -page 8, line 19 ----	6,8,30
P,Y	WO 03 023194 A (LEAVESLEY MALCOLM GEORGE) 20 March 2003 (2003-03-20) the whole document ----	2-5,7, 10, 21-26,28
A	WO 02 44527 A (ESPASA OLIVIER ;HONEYWELL GARRETT SA (FR); LOMBARD ALAIN RENE (FR)) 6 June 2002 (2002-06-06) claims; figures 1-4 ----	2,6,8, 10,21, 22,24, 25,30
A	EP 0 884 453 A (HOLSET ENGINEERING CO) 16 December 1998 (1998-12-16) the whole document -----	1-30

INTERNATIONAL SEARCH REPORT

Internat	Application No
PCT/GB	03/04961

Patent document cited in search report		Publication date	Patent family member(s)	Publication date
US 5855117	A	05-01-1999	DE 19651498 C1	16-04-1998
			FR 2756867 A1	12-06-1998
			GB 2320294 A ,B	17-06-1998
			IT RM970758 A1	11-06-1998
DE 19924228	A	07-12-2000	DE 19924228 A1	07-12-2000
			EP 1180198 A1	20-02-2002
			JP 2003522310 T	22-07-2003
			WO 0073630 A1	07-12-2000
EP 0678657	A	25-10-1995	EP 0678657 A2	25-10-1995
			AT 135440 T	15-03-1996
			AT 173794 T	15-12-1998
			AU 3693089 A	12-12-1989
			DE 68925977 D1	18-04-1996
			DE 68925977 T2	24-10-1996
			DE 68928865 D1	07-01-1999
			DE 68928865 T2	01-07-1999
			EP 0442884 A1	28-08-1991
			WO 8911583 A1	30-11-1989
			GB 2236806 A ,B	17-04-1991
GB 2271814	A	27-04-1994	NONE	
WO 03023194	A	20-03-2003	WO 03023194 A1	20-03-2003
WO 0244527	A	06-06-2002	WO 0244527 A1	06-06-2002
			AU 2181201 A	11-06-2002
			CA 2423755 A1	06-06-2002
			EP 1337739 A1	27-08-2003
			HU 0302896 A2	29-12-2003
EP 0884453	A	16-12-1998	GB 2326198 A	16-12-1998
			DE 69809130 D1	12-12-2002
			DE 69809130 T2	17-07-2003
			EP 0884453 A1	16-12-1998
			JP 11072008 A	16-03-1999
			US 5868552 A	09-02-1999
			US 5941684 A	24-08-1999