

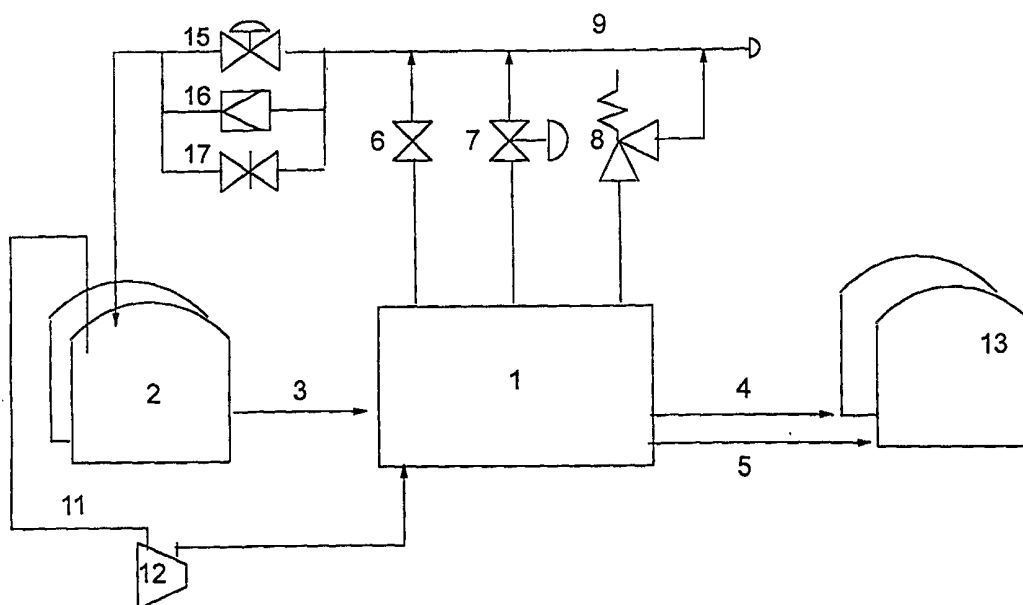

## INTERNATIONAL APPLICATION PUBLISHED UNDER THE PATENT COOPERATION TREATY (PCT)

(51) International Patent Classification <sup>6</sup> : <b>F17C 13/12, F25J 1/00</b>	<b>A1</b>	(11) International Publication Number: <b>WO 99/54658</b> (43) International Publication Date: 28 October 1999 (28.10.99)
<p>(21) International Application Number: PCT/NO99/00123</p> <p>(22) International Filing Date: 16 April 1999 (16.04.99)</p> <p>(30) Priority Data: 19981734 17 April 1998 (17.04.98) NO</p> <p>(71) Applicant (for all designated States except US): NORSK HYDRO ASA [NO/NO]; N-0240 Oslo (NO).</p> <p>(72) Inventors; and (75) Inventors/Applicants (for US only): OVERÅ, Sverre, Johannesen [NO/NO]; Aspeggaugveien 10 A, N-0376 Oslo (NO). SALATER, Per [NO/NO]; Maridalsveien 64-6, N-0458 Oslo (NO).</p> <p>(74) Agent: HOFSETH, Svein; Norsk Hydro ASA, N-0240 Oslo (NO).</p>	<p>(81) Designated States: AL, AM, AT, AU, AZ, BA, BB, BG, BR, BY, CA, CH, CN, CU, CZ, DE, DK, EE, ES, FI, GB, GD, GE, GH, GM, HR, HU, ID, IL, IN, IS, JP, KE, KG, KP, KR, KZ, LC, LK, LR, LS, LT, LU, LV, MD, MG, MK, MN, MW, MX, NO, NZ, PL, PT, RO, RU, SD, SE, SG, SI, SK, SL, TJ, TM, TR, TT, UA, UG, US, UZ, VN, YU, ZW, ARIPO patent (GH, GM, KE, LS, MW, SD, SL, SZ, UG, ZW), Eurasian patent (AM, AZ, BY, KG, KZ, MD, RU, TJ, TM), European patent (AT, BE, CH, CY, DE, DK, ES, FI, FR, GB, GR, IE, IT, LU, MC, NL, PT, SE), OAPI patent (BF, BJ, CF, CG, CI, CM, GA, GN, GW, ML, MR, NE, SN, TD, TG).</p> <p><b>Published</b> With international search report.</p>	

(54) Title: PROCESS PLANT



## (57) Abstract

A process plant (1) for handling combustibles fluids, for example an oil production plant in which gaseous hydrocarbons are separated from oil and in which surplus gases or residual gases from uncontrolled build-ups of gas pressure in the process escape through process or safety valves in the plant and are conducted to a collection line (9). The surplus or residual gases are conducted via the collection line (9) to one or more low-pressure stores (2) and a connection line or return line (11, 3) is arranged from the store(s) (2) to the process or another treatment unit for processing the returned or collected fluid. The low-pressure store(s) can expediently comprise the crude oil or raw product store (2) of the process plant upstream of the process plant.

**FOR THE PURPOSES OF INFORMATION ONLY**

Codes used to identify States party to the PCT on the front pages of pamphlets publishing international applications under the PCT.

AL	Albania	ES	Spain	LS	Lesotho	SI	Slovenia
AM	Armenia	FI	Finland	LT	Lithuania	SK	Slovakia
AT	Austria	FR	France	LU	Luxembourg	SN	Senegal
AU	Australia	GA	Gabon	LV	Latvia	SZ	Swaziland
AZ	Azerbaijan	GB	United Kingdom	MC	Monaco	TD	Chad
BA	Bosnia and Herzegovina	GE	Georgia	MD	Republic of Moldova	TG	Togo
BB	Barbados	GH	Ghana	MG	Madagascar	TJ	Tajikistan
BE	Belgium	GN	Guinea	MK	The former Yugoslav Republic of Macedonia	TM	Turkmenistan
BF	Burkina Faso	GR	Greece			TR	Turkey
BG	Bulgaria	HU	Hungary	ML	Mali	TT	Trinidad and Tobago
BJ	Benin	IE	Ireland	MN	Mongolia	UA	Ukraine
BR	Brazil	IL	Israel	MR	Mauritania	UG	Uganda
BY	Belarus	IS	Iceland	MW	Malawi	US	United States of America
CA	Canada	IT	Italy	MX	Mexico	UZ	Uzbekistan
CF	Central African Republic	JP	Japan	NE	Niger	VN	Viet Nam
CG	Congo	KE	Kenya	NL	Netherlands	YU	Yugoslavia
CH	Switzerland	KG	Kyrgyzstan	NO	Norway	ZW	Zimbabwe
CI	Côte d'Ivoire	KP	Democratic People's Republic of Korea	NZ	New Zealand		
CM	Cameroon			PL	Poland		
CN	China	KR	Republic of Korea	PT	Portugal		
CU	Cuba	KZ	Kazakstan	RO	Romania		
CZ	Czech Republic	LC	Saint Lucia	RU	Russian Federation		
DE	Germany	LI	Liechtenstein	SD	Sudan		
DK	Denmark	LK	Sri Lanka	SE	Sweden		
EE	Estonia	LR	Liberia	SG	Singapore		

### Process plant

The present invention relates to a process plant for handling combustible fluids, for example an oil production plant in which gaseous hydrocarbons are separated from oil and in which surplus gases or residual gases from uncontrolled build-ups of gas pressure in the process escape through process or safety valves in the process plant and are conducted to a collection line.

It should be stressed that the expression process plant means not only plants for oil production in which hydrocarbon gases are separated from oil, but also refining plants and all types of equipment or plant in which combustible fluids are formed which must be handled optimally in terms of safety, finance and the environment.

In a process plant, for example a plant for the production of oil, there will normally be a large number of separators, compressors and/or other process equipment which are connected, in the process pipe line system, with valves, pressure regulators, temperature regulators and other components which, in given situations, may fail and lead to leaks, uncontrolled build-up of pressure, etc. The plant therefore has integral safety systems in the form of pressure control valves, safety valves and blow down valves which are connected to and will conduct surplus or residual fluids to a collection line for further transport to a flare for burning or emission into the atmosphere. In connection with flare burning, a combustion gas is usually added to the collection line continuously to ensure that a minimum flame is maintained in the flare. In connection with emission into the atmosphere without burning, an inert gas is usually added to prevent explosion.

British patent application no. 2.066.936 describes a refining plant for oil in which surplus gases in the form of hydrocarbons are recovered. The surplus gases are diverted from a flare line system and condensed in one or more stages by compression and cooling. The condensate is returned to the process. The residual gas, however, is conducted to a flare tower and burned.

East German patent specification no. 266.006 mentions a plant for combining combustible gases from several sources with different compositions in two main streams. The gases are combined using a computer which regulates the mixture on the basis of measurements of the calorific value of the gases. The gases are burned in a flare tower.

Moreover, Norwegian patent no. 177161 describes a solution for recovering surplus gas from an oil/gas treatment plant in which the surplus gas is collected in a collection line and recovered while gas which escapes in an emergency situation in connection with an abnormal increase in pressure (blow out) is conducted to a branch line for burning in a flare tower.

For all of the above known solutions, flares are used to burn all or part of the surplus gases or residual gases from the process plant. However, the use of a flare entails several disadvantages:

- The construction of the flare (flare tower) in itself is very expensive and will account for a not inconsiderable part of the overall costs of a process plant.
- Burning or emitting the surplus gases represents an environmental problem as CO<sub>2</sub> and hydrocarbon gases will, among other things, contribute to the greenhouse effect.
- The surplus gases or fluids are valuable in themselves and represent a direct financial loss when burned or emitted into the environment.

The present invention describes a device in connection with a process plant in which the stated disadvantages have been eliminated, i.e. in which the flare has been removed and all surplus gases and residual gases are dealt with and recycled.

The present invention is characterised in that the surplus or residual gases are conducted via a collection line to one or more low-pressure stores and that a connection line or return line is arranged from the store's gas area to the process or another treatment unit for the processing of the gas.

Claims 2-3 define advantageous features of the invention.

The present invention will be described in the following in further detail by means of examples and with reference to the attached drawings, where

Fig. 1 shows a simplified process diagram for a traditional process plant with a flare tower.

Fig. 2 shows a simplified process diagram for a process plant in accordance with the present invention without a flare tower.

Fig. 1 shows, as stated, a simplified process diagram of a traditional process plant, for example an oil production plant, in which a flare tower is used to burn the surplus gases. The raw product or crude oil is added to the process 1 from one or more low-pressure crude oil stores 2 via a line 3. The process itself may comprise several process stages with compressors and condensers (not shown) and is designed to separate gaseous hydrocarbons from the oil and transfer them as processed products, for example via lines 4, 5, to an appropriate product store 13.

A process plant like this will, as stated in the introduction, contain equipment and components, for example valves, pressure regulators and temperature regulators, which may fail and lead to leaks and build-ups of pressure. The plant will, therefore, be fitted with blow down valves (BDV), pressure control valves (PV) and pressure safety valves (PSV) 6, 7, 8, which are designed to allow fluid (gas) to escape in

connection with a shutdown and when unforeseen leaks or build-ups of pressure occur. These fluids are collected in a collection line 9 and conducted to a flare tower 10 for burning or emission into the atmosphere. In the latter case, inert gas is also added from an inert gas source (not shown) via line 14.

Fig. 2 shows a simplified process diagram of the solution in accordance with the present invention. The process is the same as in the example shown in Fig. 1 and described above but the flare tower has been eliminated by the fluid which is collected in the collection line 9 being returned to the low-pressure crude oil store 2 upstream of the process plant.

Surplus gases which are collected in the store 2 can expediently be returned to the process as gas for reuse via line 11. If the conditions are present, some of the gas will condense in the low-pressure store 2. This condensed gas and any liquid from the fluid can expediently be returned to the process via the raw product line 3. In order to create lower pressure and thus increased capacity in the store 2, a fan or compressor 12 can also be arranged in connection with the return line 11. It should be noted that the present invention will require a relatively large store volume to be able to work within fixed safety margins. Such a volume will usually exist at all major crude oil plants.

However, it should also be noted that the present invention as it is described in the claims is not restricted to a solution in which the surplus gases or fluids have to be conducted to the low-pressure product store. It is possible to establish a separate store volume, for example a separate tank to which the surplus gases are conducted. Moreover, the collected gas or fluid (liquid) does not have to be returned to the process but can be conducted to another separate treatment unit (not shown). Moreover, a control valve 15 should be arranged in connection with the collection line 9 in order to isolate the low-pressure store 2 from the process when the plant is not in operation. Moreover, surplus pressure protection 17 should be arranged in parallel with the control valve 15 in case the latter fails to open. A manual stop valve (diverter

valve) 17 should be used to allow maintenance of the control valve 15 and the surplus pressure protection 17.

The present invention describes a solution in connection with a process plant which has a number of advantages compared with the known solutions:

- The use of a flare tower with associated equipment is completely eliminated and the investment costs in connection with the construction of the process plant and the maintenance costs are therefore considerably less.
- By eliminating the use of a flare, emissions of environmentally hazardous hydrocarbon gases, CO<sub>2</sub> and NO<sub>x</sub> gases are avoided. At the same time, major savings are achieved as there will be no need to add gas to the pilot flare and as the surplus gases are returned to the process and "reused".
- As the construction of a flare tower is not necessary, the visually unattractive structure of the flare tower is also avoided. Moreover, the unattractive flare, the high noise level and the smoke which are associated with the use of a flare are also avoided.
- Moreover, the present invention offers an improvement in safety, among other things because the use of an open flame is eliminated and the relief of surplus pressure built up will be shorter?.

6  
Claims

1. Process plant (1) for handling combustible fluids, for example an oil production plant in which gaseous hydrocarbons are separated from oil and in which surplus gases or residual gases from uncontrolled build-ups of gas pressure in the process escape through process or safety valves in the plant and are conducted to a collection line (9).  
c h a r a c t e r i s e d i n t h a t  
the surplus or residual gases are conducted via the collection line (9) to one or more low-pressure stores (2) and that a connection line or return line (11, 3) is arranged from the store(s) (2) to the process or another treatment unit for processing the returned or collected fluid.
2. Process plant according to claim 1,  
c h a r a c t e r i s e d i n t h a t  
the low-pressure store(s) comprise(s) the crude oil or raw product store (2) of the process plant upstream of the process plant.
3. Process plant according to claim 1,  
c h a r a c t e r i s e d i n t h a t  
the return line (11) is connected to the gas area of the raw product store and that any condensed gas and liquid from the fluid which is added to the store (2) via the collection line (9) is returned to the process via the raw product line (3).
4. Process plant according to claim 3,  
c h a r a c t e r i s e d i n t h a t  
a fan or compressor (12) is arranged in connection with the return line (11).

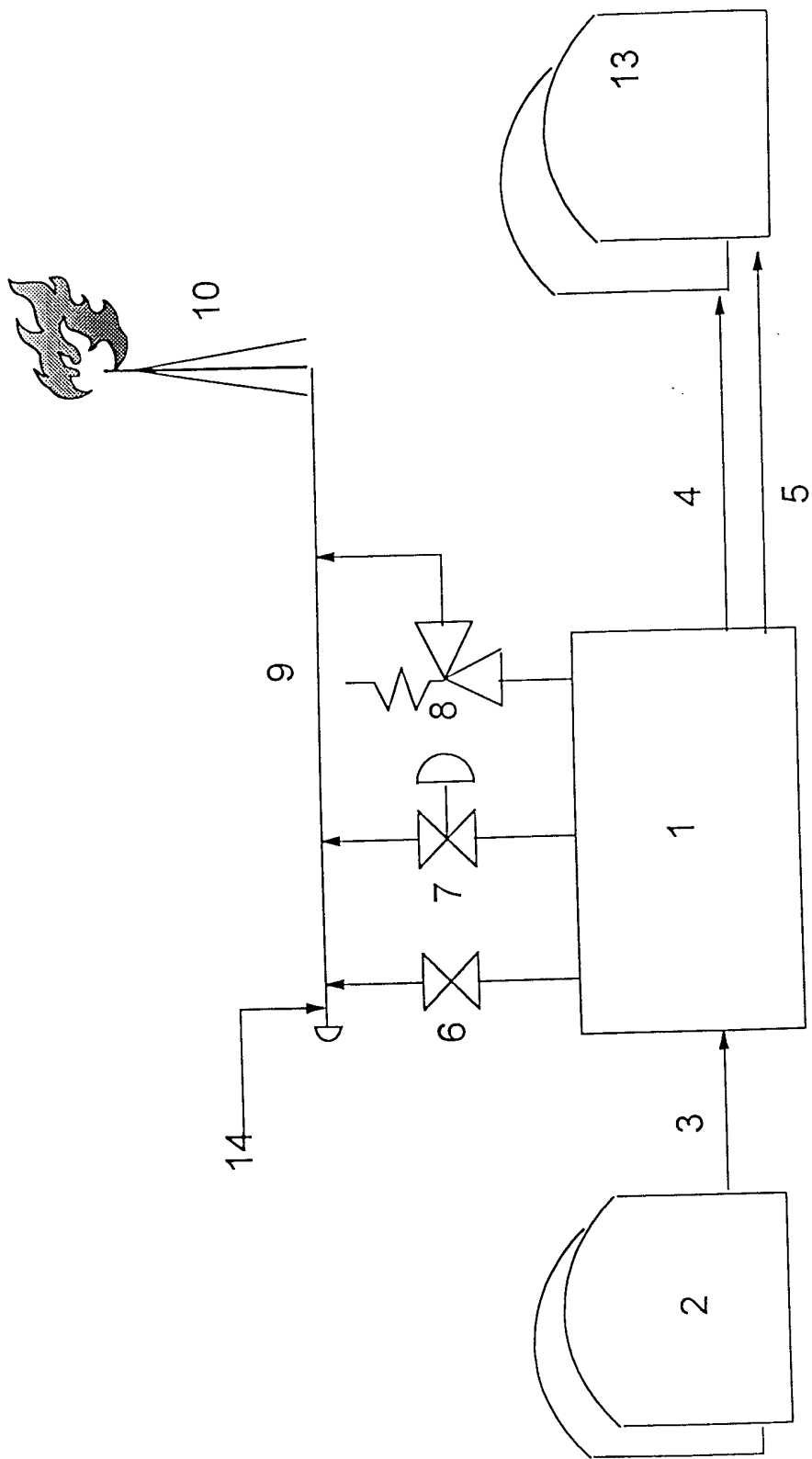

Fig.1

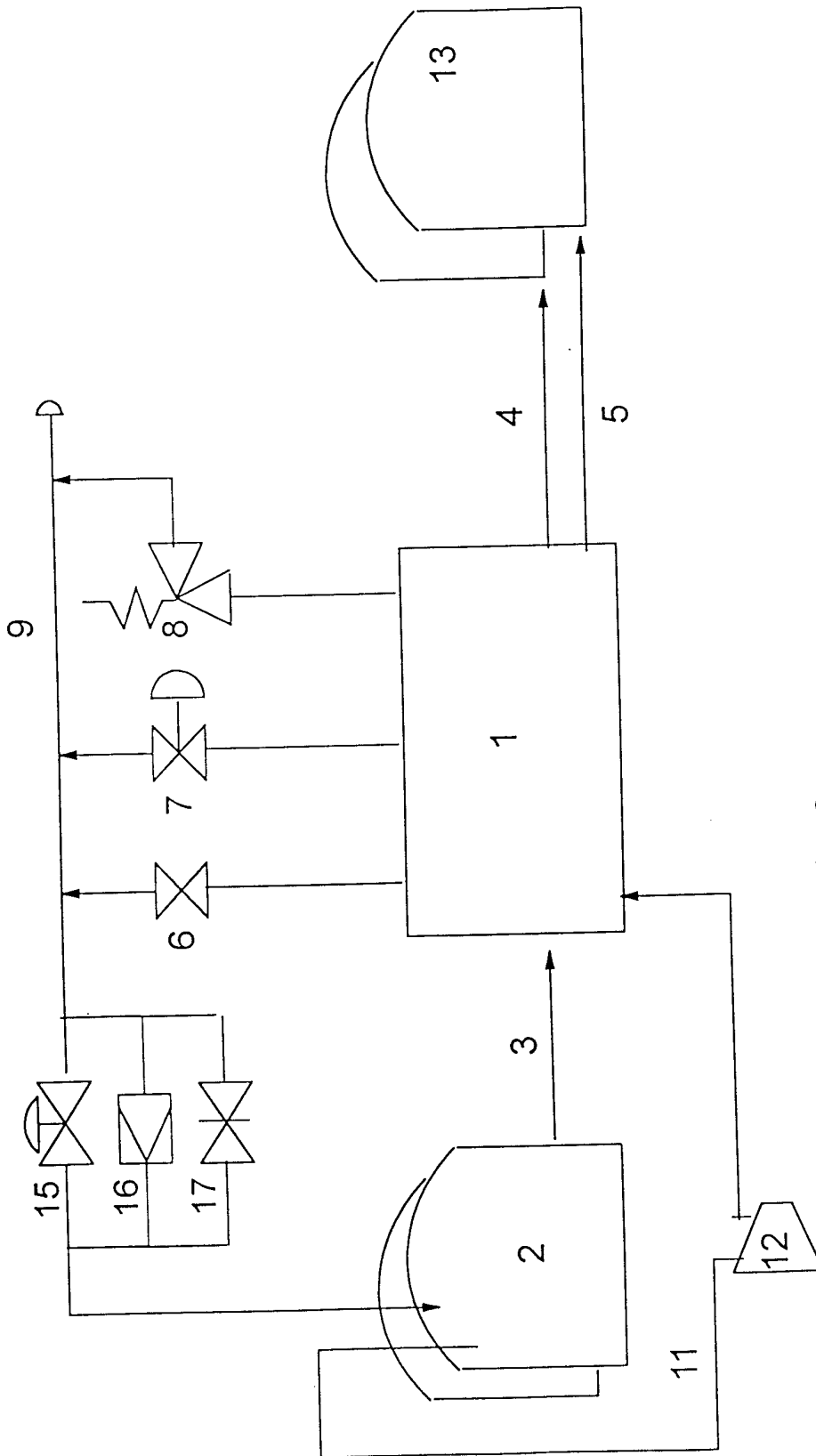

Fig. 2

## INTERNATIONAL SEARCH REPORT

International application No.

PCT/NO 99/00123

## A. CLASSIFICATION OF SUBJECT MATTER

IPC6: F17C 13/12, F25J 1/00

According to International Patent Classification (IPC) or to both national classification and IPC

## B. FIELDS SEARCHED

Minimum documentation searched (classification system followed by classification symbols)

IPC6: F17C, F25J

Documentation searched other than minimum documentation to the extent that such documents are included in the fields searched

SE,DK,FI,NO classes as above

Electronic data base consulted during the international search (name of data base and, where practicable, search terms used)

EPODOC, WPI

## C. DOCUMENTS CONSIDERED TO BE RELEVANT

Category*	Citation of document, with indication, where appropriate, of the relevant passages	Relevant to claim No.
X	WO 9425541 A1 (DEN NORSKE STATS OLJESELSKAP A.S.), 10 November 1994 (10.11.94), page 7, line 14 - line 23  -- -----	1-4

 Further documents are listed in the continuation of Box C.
  See patent family annex.

* Special categories of cited documents:	"T" later document published after the international filing date or priority date and not in conflict with the application but cited to understand the principle or theory underlying the invention
"A" document defining the general state of the art which is not considered to be of particular relevance	"X" document of particular relevance: the claimed invention cannot be considered novel or cannot be considered to involve an inventive step when the document is taken alone
"E" earlier document but published on or after the international filing date	"Y" document of particular relevance: the claimed invention cannot be considered to involve an inventive step when the document is combined with one or more other such documents, such combination being obvious to a person skilled in the art
"L" document which may throw doubts on priority claim(s) or which is cited to establish the publication date of another citation or other special reason (as specified)	"&" document member of the same patent family
"O" document referring to an oral disclosure, use, exhibition or other means	
"P" document published prior to the international filing date but later than the priority date claimed	

Date of the actual completion of the international search <b>17 June 1999</b>	Date of mailing of the international search report <b>08 -07- 1999</b>
Name and mailing address of the ISA/ Swedish Patent Office Box 5055, S-102 42 STOCKHOLM Facsimile No. +46 8 666 02 86	Authorized officer <b>Jan Carlerud/MP</b> Telephone No. +46 8 782 25 00

