

Sept. 2, 1958

C. A. BAUMAN ET AL

2,850,561

ELECTRIC FENCE SUPPORT

Filed June 7, 1955

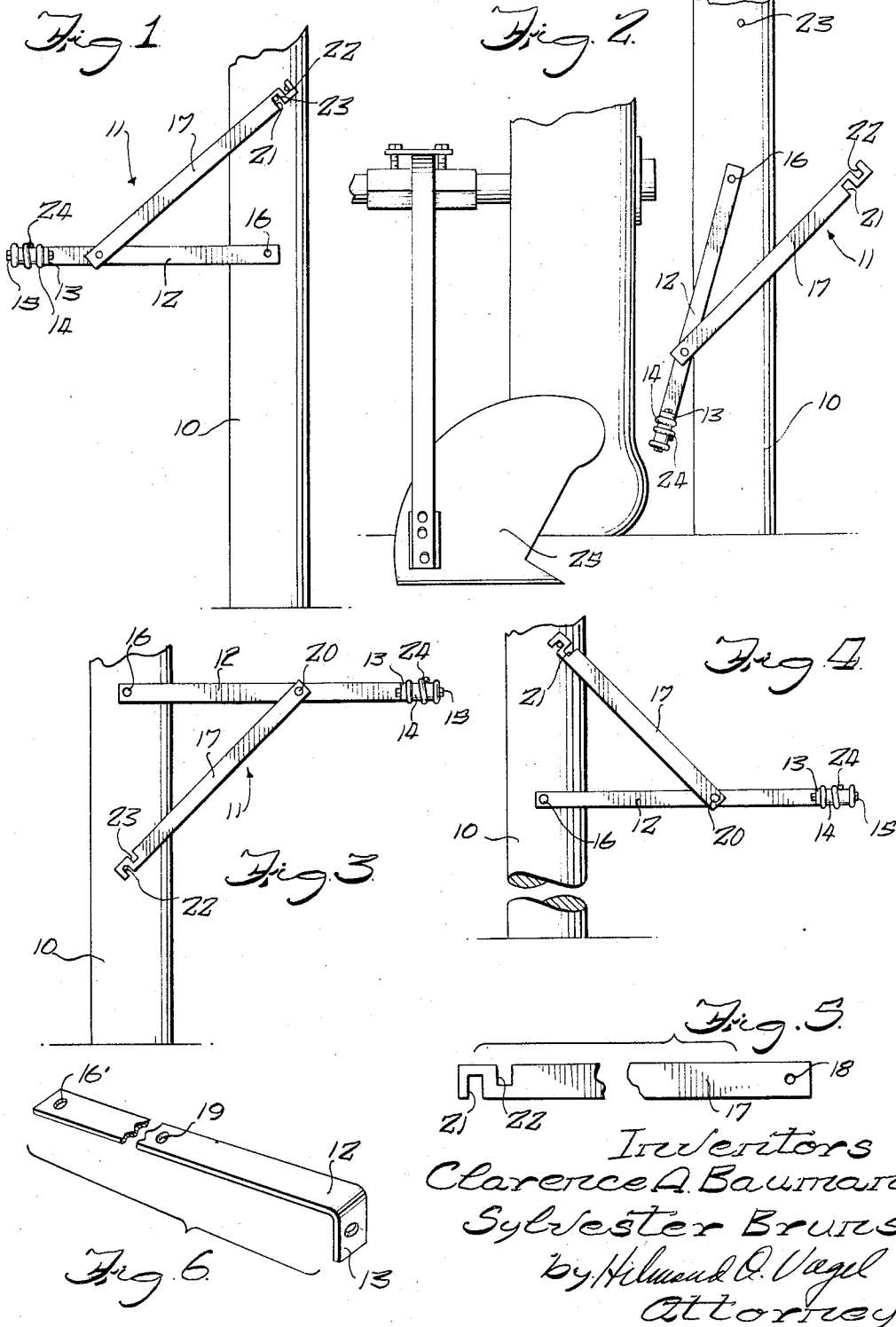

Inventors
Clarence A. Bauman
Sylvester Brunns
by Hilman D. Vogel
Attorney

1

2,850,561

ELECTRIC FENCE SUPPORT

Clarence A. Bauman, Pontiac, and Sylvester Bruns,
Graymont, Ill.

Application June 7, 1955, Serial No. 513,878

1 Claim. (Cl. 174-161)

This invention relates to a support for electric wire fences. More particularly this invention relates to a collapsible support of a type used in connection with supporting intermittently charged electric fence wire.

Various types of supporting devices have been developed in the past for supporting the wire which is the component of electric fencing. Electric fencing generally consists of a wire which is strung along the fence posts of a pasture or portion of land which is to be fenced, this electric wire being suitably intermittently charged with electricity to maintain stock within the area which is thusly fenced. Numerous supporting devices for the fence wire have been developed but generally these have been relatively expensive and difficult to apply. Furthermore, permanent supporting devices for such electric fences have made it extremely difficult for the farmer to plow or otherwise work in close proximity to the edge of the field which is generally defined by the various fence posts which support the wire. It is a prime object of this invention therefore to provide an improved supporting device for supporting electric fence wire.

Another object is to provide an improved supporting device for electric fence wire, the said device being readily collapsible from a normal operating position to thereby permit the farmer to disconnect the support and to collapse the same to an out-of-the-way position so that he can readily maneuver his equipment adjacent the fence post for plowing or conducting other farm chores.

A still further object is to provide an improved relatively simple supporting device for electric wire fences, the device being inexpensive and quickly assembled with a suitable post, the said device also being readily disconnectable so that it can be stored in an out-of-the-way position for a period of time which necessitates the working of equipment close to the fence structure.

These and other objects will become more readily apparent from a reading of the specification when examined in connection with the accompanying drawing.

In the drawing:

Figure 1 is a side elevational view of a permanent fence post having a collapsible improved electric wire fence support connected thereto;

Figure 2 is a view of an electric wire fence support shown in Figure 1, the said support being shown in a collapsed position while certain farm equipment is working close adjacent to the said support;

Figure 3 is a view similar to Figure 1, showing a supporting device for electric wire fences positioned opposite to that shown in Figure 1;

Figure 4 is a side elevational view similar to Figure 3 showing the wire fence support in a modified position;

Figure 5 is a detail view of a brace structure; and

Figure 6 is a detail view in perspective of a supporting arm for a wire fence support.

As indicated in Figures 1 through 4, a post 10 is generally firmly supported within the ground. The post

2

10 is of conventional construction generally used in connection with fences and a plurality of these posts may be placed along the margin of the field which is sought to be enclosed. An electric fence support is generally designated by the reference character 11. The fence support 11 comprises a normally horizontally extending arm 12 having at one end a right angle flange 13 on which an insulator 14 of conventional construction is positioned by means of a bolt 15. A nail or suitable screw 16 is placed through a hole 16' in the arm 12 and extends into the post 10 for hingedly mounting the said arm 12 with respect to the post 10.

A brace 17, also well shown in Figure 5, is provided with a hole 18 which is placed in registry with a hole 19 formed in the arm 12. A rivet 20 extends through the holes 18 and 19 to suitably connect the brace 17 to the arm 12 in relative hinging relation. The brace 17 is further provided at one end with slots 21 and 22, these slots having open ends opening outwardly on opposite sides of the brace 17. The slots 21 and 22 extend relatively transversely with respect to the brace 17 and in substantially parallel relation. A nail or other suitable fastening member which projects from the post 10 is securely fastened to the said post, the same fastening member 23 being adapted to be engaged by the slots 21 and 22 as best shown in Figures 1 through 4.

An electric fence wire 24 may be suitably supported on the insulator 14. It is, of course, understood that a plurality of the fence supports 11 are provided and that the farmer can very simply set these in position by nailing the arm 16 onto the fence post 10 and by placing another nail 23 either below the nail 16 or above the nail 16 as shown in Figures 3 and 4. Thus by the driving of two nails or screws the electric fence support 11 is placed in position. The nail 16 permits the arm 12 to hinge onto the out-of-the-way position shown in Figure 2 by simply unhooking the slot 21 from the nail 23 whereupon collapse of the fence support occurs. Thus as indicated in Figure 2 the support 11 is placed in an out-of-the-way position and a plow or other farm equipment device may be utilized to work closely adjacent to the post 10. This permits the farmer to work his field to the maximum utmost efficiency since he can quickly disconnect the supports while he is working adjacent the fence line.

As shown in Figures 3 and 4 the braces 17 may be connected either above or below the arm 12 whichever is desired. Furthermore, either of the slots 21 or 22 may be utilized. The slots 21 and 22 also permit a certain amount of vertical adjustment of the arm 12 depending on whichever one is utilized in connection with the fastening member or nail 23. As shown in Figure 2, the farmer can easily move the support to a collapsed position when working to the post with an implement like a wheeled plow 25.

Thus a relatively simple though effective fence support has been disclosed. The economy of this type of support is believed to be self-evident because of the quick disconnectable feature of the fence support the farmer can very quickly place the support in an out-of-the-way position which will permit him to work closely adjacent to the fence line and thus realize maximum utility of his acreage. Furthermore, by placing the support in the position shown in Figures 1 and 4, mowing and other projects can be accomplished without the necessity of collapsing the support. Thus the object of the invention has been fully achieved and it must be understood that changes and modifications may be made which do not depart from the spirit of the invention as disclosed or the scope thereof as defined in the appended claim.

What is claimed is:

An electric fence wire support adapted to be connected to an upright post comprising; a normally horizontal supporting arm, means pivotally connecting one end of said supporting arm to an upright post, an insulating member connected to an opposite end of said arm, said insulating member being adapted to carry an intermittently charged electric fence wire, a normally diagonally extending brace, means pivotally connecting one end of said brace to said arm substantially adjacent said insulating member, said brace having a first open end slot adjacent an opposite end thereof, said first slot opening outwardly on one side of said brace, said brace including a second open end slot adjacent said first slot, said second slot opening outwardly on an opposite side of said brace, said slots extending in substantially parallel relative relation, said arm being swingable about its pivotal connection from one side of the post to the other side, with the brace being diagonally positioned so that one slot has its open

end facing generally downwardly and the other slot has its open end facing generally upwardly, whereby a securing member projecting outwardly from said post engages one of said slots, the slot so engaged in each case being the slot which has its open end facing downwardly, the securing member maintaining the brace and arm in the normal position, said brace being quickly disconnectable from said post by moving said brace upwardly to disengage one slot from the securing member to permit swinging of the arm and a wire supported thereby to an out-of-the-way position.

References Cited in the file of this patent

UNITED STATES PATENTS

1,138,702	Varney	May 11, 1915
1,371,256	Michaelson	Mar. 15, 1921
1,743,168	Thomason et al.	Jan. 14, 1930
2,485,288	Homann	Oct. 18, 1949