

E. T. ALLEN.
BURIAL VAULT.

APPLICATION FILED JUNE 13, 1903.

NO MODEL.

2 SHEETS—SHEET 1.

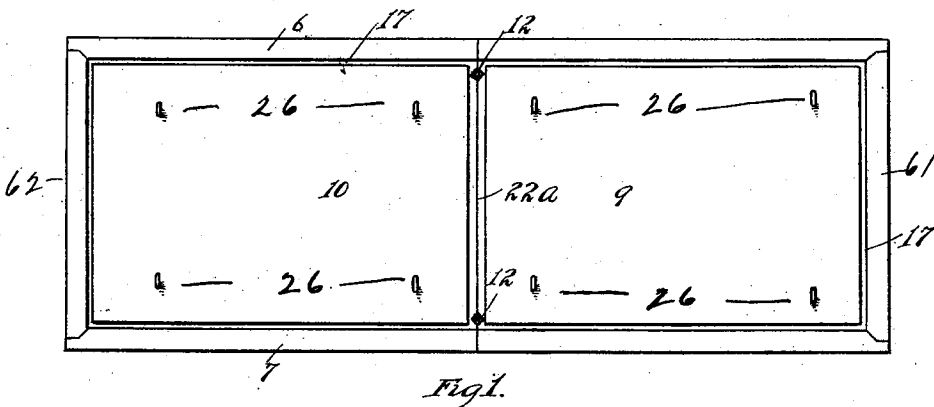
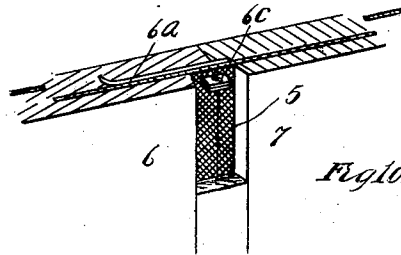
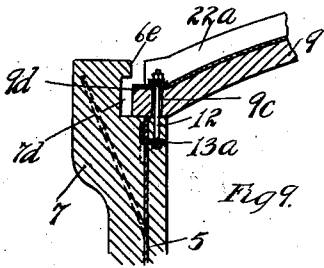
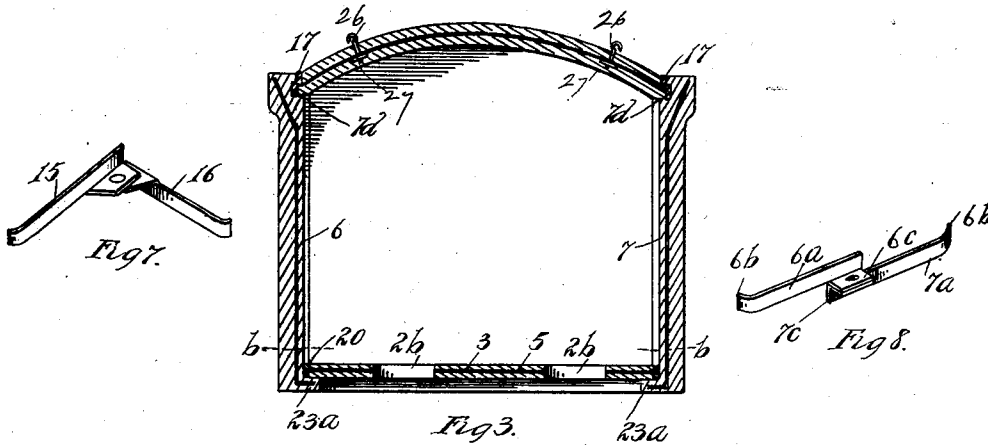

WITNESSES
J. G. Massey
Lotta Lee Hayton.

INVENTOR
Edwin J. Allen
 By *Parker & Burton*
 Attorneys.

E. T. ALLEN.
BURIAL VAULT.

APPLICATION FILED JUNE 13, 1903.

NO MODEL.

2 SHEETS—SHEET 2.

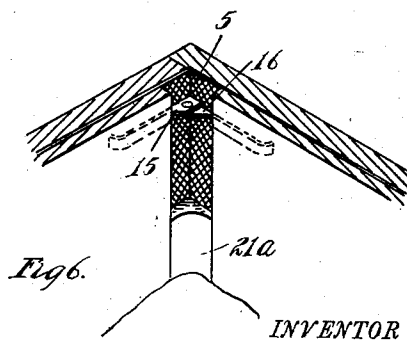
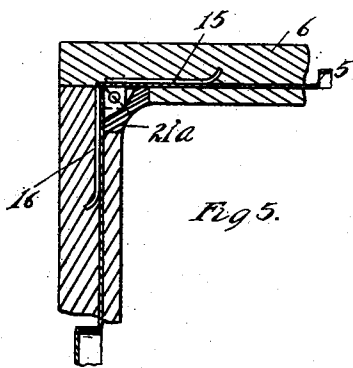
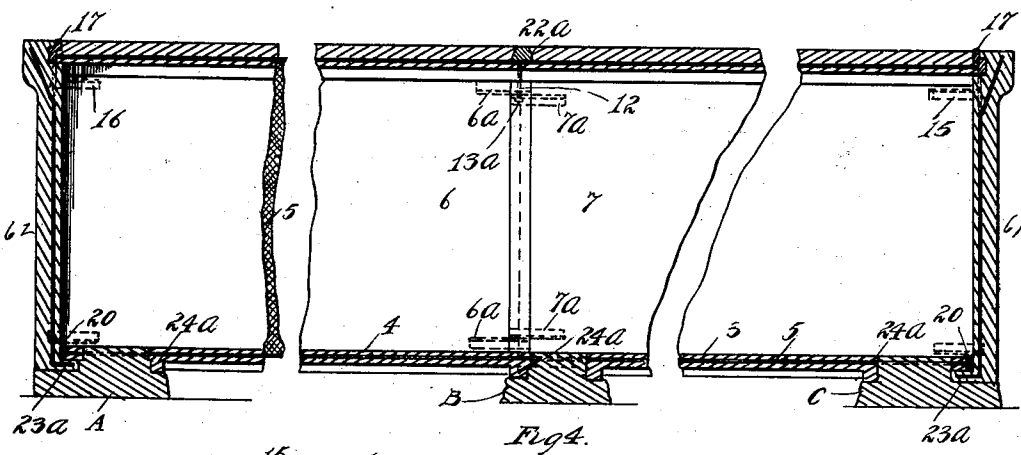
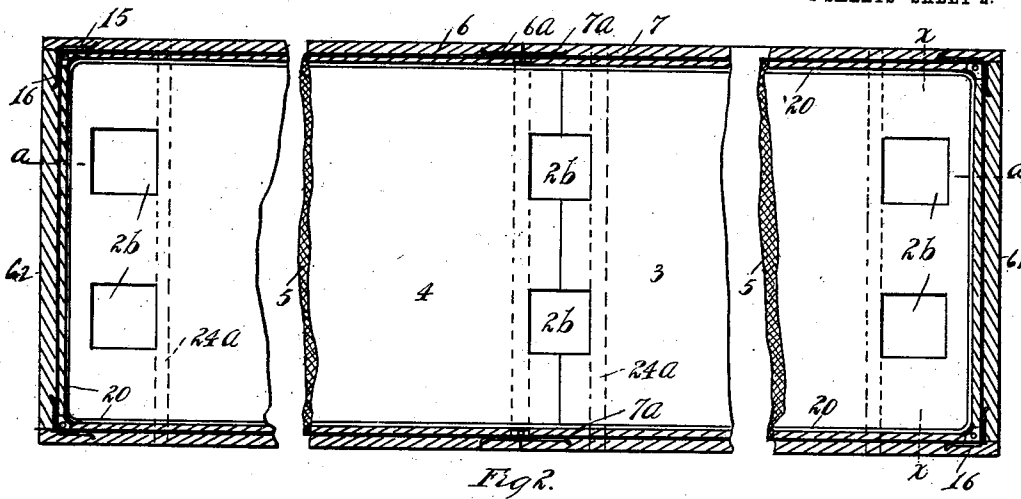

WITNESSES
J. W. Mearns
Lotta Lee Houghton.

INVENTOR
Edwin T. Allen
 By *Parker V. Burton*
 Attorneys.

UNITED STATES PATENT OFFICE.

EDWIN T. ALLEN, OF DETROIT, MICHIGAN.

BURIAL-VAULT.

SPECIFICATION forming part of Letters Patent No. 755,986, dated March 29, 1904.

Application filed June 13, 1903. Serial No. 161,260. (No model.)

To all whom it may concern:

Be it known that I, EDWIN T. ALLEN, a citizen of the United States, residing at Detroit, county of Wayne, State of Michigan, have invented a certain new and useful Improvement in Burial-Vaults; and I declare the following to be a full, clear, and exact description of the invention, such as will enable others skilled in the art to which it pertains to make and use the same, reference being had to the accompanying drawings, which form a part of this specification.

This invention relates to burial-vaults, and has for its object an improved case for the interment of the dead.

The object of the invention is to produce a secure strong water and air tight as well as a burglar-proof vault of sufficient size to receive the coffin and in effect constitute a sealed monolithic structure.

In the drawings, Figure 1 is a plan of the cover of the vault as seen from the outside. Fig. 2 is a longitudinal section at the line *b b* of Fig. 3. Fig. 3 is a cross-section at line *x x* of Fig. 2. Fig. 4 is a vertical longitudinal section at line *a a* of Fig. 2. Fig. 5 is a horizontal sectional detail of a corner. Fig. 6 is a perspective of a corner. Fig. 7 is a detail of the connecting-irons at a corner. Fig. 8 is a detail of connection of the irons at the meeting end of side slabs. Fig. 9 is a detail showing the joint between the cover and side. Fig. 10 is a perspective showing the joint at meeting ends of the side slabs.

The vault is made of slab-like parts for convenience of transportation, and these are assembled and secured together at the place of use. There are several slab-like pieces, each of which is composed of artificial stone made on a metal mesh. The slabs are arranged to be assembled into case form and to be secured in their assembled position by bolts or pins which are entirely within the slabs and are entirely covered and concealed by a sealing of material similar to that of which the case is constructed.

A, B, and C, Fig. 4, indicate three blocks of artificial stone which are formed by grouting with cement or concrete through the holes 2^b in the bottom slabs, Figs. 2, 3, and 4. These

blocks are made after all parts have been assembled, excepting the cover. The spaces for the blocks A, B, and C are made in the earth before placing the bottom in position and entered under the sides and ends as far as may seem necessary. It is preferable that the bottom be made in two slabs 3 and 4 of unequal length, making the joint between them at one side of the middle line across the case. The bottom slabs have ribs 24^a molded along the bottom, two or more to each slab, Figs. 2 and 4. These ribs are of substantially the same thickness as the flanges 23^a, Figs. 3 and 4, which are molded along the lower edges of both the end and side slabs and are clearly shown. The purpose of the above-mentioned ribs is to add strength to the bottom and to confine the grouting A, B, and C, Fig. 4. The bottom slabs 3 and 4 are made with metal embedded therein, preferably expanded metal, (indicated at 5, Fig. 2,) and are sealed in position by pouring onto joints 20, Figs. 2, 3, and 4, liquid cement and then troweling down.

The sides 6 and 7, Fig. 4, are built with metal embedded therein which is of the same character as that used in the bottom slabs and are preferably made in two slabs of equal length and are connected together by two or more overlapping bars of iron, (shown in detail in Fig. 8,) which are embedded in the sides 6 and 7 in such a manner as to leave the lugs 6^c and 7^c of the irons 6^a and 7^a extending through the metal mesh so that they will just pass each other when the side slabs are butted together, thereby bringing the bolt or rivet holes in the two lugs directly into register, and the bolt or rivet is passed through both irons. The extreme ends of irons 6^a and 7^a are turned up, as at 6^b, so as to prevent them loosening from the cement. The stud-bolt 12 used in the top joint 13^a is of sufficient length to pass through irons embedded in the parts of the cover at their joints and projects far enough for washer and nut; but the end of the bolt is entirely below the top surface of the cover. The side slabs 6 and 7, Fig. 4, are also provided at their ends with two or more overlapping irons, (shown in detail in Fig. 7,) with lugs that project through the mesh of metal, as described for middle joints, but made to

connect with corresponding irons placed in the end slabs hereinafter described. Each of the side pieces 6 and 7 is provided at its upper edge with a rabbet 7^d, on which the edges 5 of the top slabs 9 and 10 rest, and over the rabbet is an overhang 6^e, that projects inward to register with the outer edge 9^d of the top slab, thus forming a perfect seal when poured full of liquid cement and troweled down. At 10 the extreme bottom edge of the slabs 6 and 7 there is a return-flange 23^a, Fig. 3, on which the bottom slabs 3 and 4 rest, thereby preventing the weight of the coffin from breaking the bottom loose from the sides.

15 The end slabs 61 62 are each made in one piece, built on embedded metal of the same character as that used in the bottom and sides. There are at least two overlapping bars of iron 15 and 16, Fig. 5, at either side 20 embedded in cement at such position as to just engage corresponding irons built in sides 6 and 7, thereby making the bolt or pin holes of the irons register to receive a binding bolt or pin. The top edge of each slab is arched 25 so as to conform to the shape of covers and is provided with a rabbet across its entire top edge of the same shape and form as that along the sides. Along the bottom edge the sides and ends have a return-flange 23^a, Figs. 3 and 30 4. The meeting corners of these flanges are mitered.

The top slabs are preferably two in number of equal length, built arched to conform to the shape of the top edge of ends, and built on embedded 35 foundation of metal of the same character as that used in the foundation of the sides and bottom. Said metal is bent to the required curve of cover. The cover is bolted to the sides at its joint by means of a stud-bolt 40 12, Fig. 9, which is secured as before described and is held by a lock-nut above and below, detail Figs. 8 and 9. The bolt is long enough to pass through hole 9^c, which is formed by notching to make one-half the hole in each top slab 45 at joint. The bolt projects far enough through the foundation metal of the top slabs 9 and 10 to allow for a large-size thin washer and nut. The nut is below the finished surface of the cover as it is finally completed by filling the 50 rabbet, Figs. 4 and 9, which runs across the end of each top slab, and these when the slabs

are assembled form a groove 22^a, Figs. 1 and 4. This groove 22^a, as well as the joint 17, Figs. 3 and 4, are afterward grouted full of cement and troweled down smooth. Screw-hooks 26 55 are temporarily inserted in the top and engage in holding nuts 27, that are embedded under the mesh of metal through which the ends of the screw-hooks pass to engage the nuts. After the vault has been assembled and sealed 60 the screw-hooks are withdrawn and the holes filled with cement.

Figs. 5, 6, and 10 of the drawings show the corners and joints in an incomplete state. In the finished vault all the corners and joints are 65 filled with cement suitably molded to place, and all irons and parts of irons used to bind the structure together are entirely covered.

What I claim is—

1. In a burial-vault, in combination with side 70 and end pieces, provided with inturned bottom flanges, and with means for securing the several pieces together, a foundation-slab built underneath the bottom and projecting therethrough, substantially as described. 75

2. In a burial-vault, a bottom slab therefor provided with openings and a grouting below the said bottom projecting into said openings, substantially as described.

3. In a burial-vault, the combination of slabs 80 of artificial stone, a metal mesh incorporated in each slab, a tie-iron inserted in the slab external to the mesh, said tie-irons provided with lugs extending through the metal mesh and arranged to overlap a corresponding lug on a 85 plate embedded in an adjacent slab, substantially as described.

4. In a burial-vault, in combination with side and end pieces locked together and provided with an inturned flange along the bottom, a 90 bottom slab resting on said flanges and grouting of cement arranged across underneath the bottom and engaging through openings in the bottom, the openings being filled by the cement, substantially as described. 95

In testimony whereof I sign this specification in the presence of two witnesses.

EDWIN T. ALLEN.

Witnesses:

CHARLES F. BURTON,
MAY E. KOTT.