

(No Model.)

2 Sheets—Sheet 1.

E. T. & E. H. MARBLE.

MECHANISM FOR DOUBLING WEBS OF FABRIC LONGITUDINALLY.

No. 523,363.

Patented July 24, 1894.

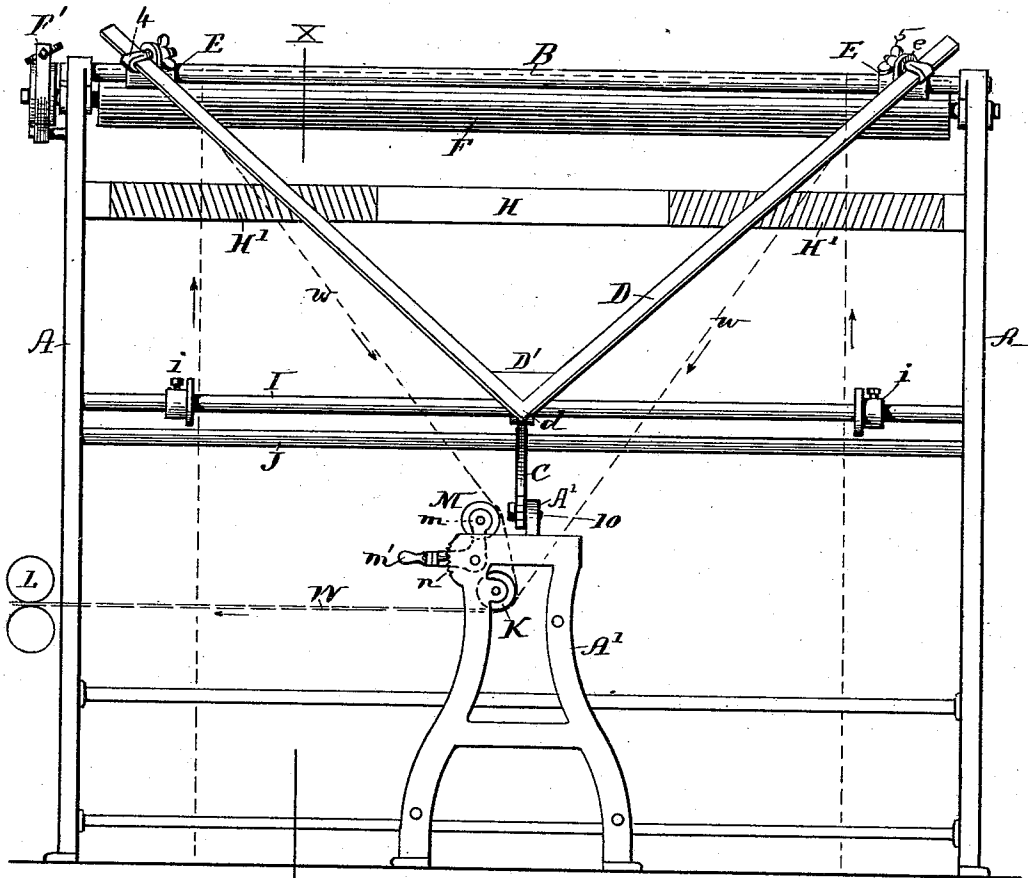

FIG. 1

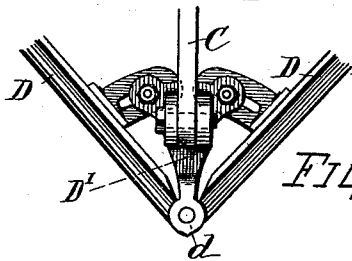

FIG. 2

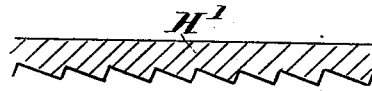

FIG. 3

WITNESSES.

*Ella P. Blenus.*  
*Simon E. King*

INVENTORS.

*Edwin T. Marble*  
*Edwin H. Marble*  
 By *Chas. H. Burleigh*  
 Attorney

(No Model.)

2 Sheets—Sheet 2.

E. T. & E. H. MARBLE.

MECHANISM FOR DOUBLING WEBS OF FABRIC LONGITUDINALLY.

No. 523,363.

Patented July 24, 1894.

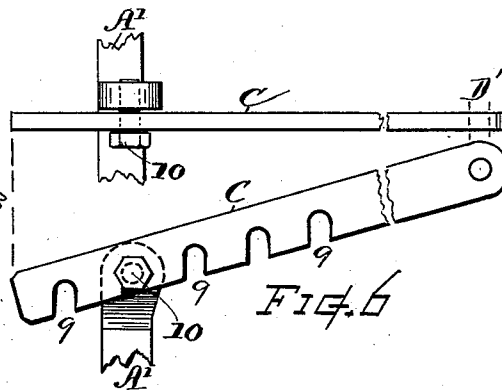
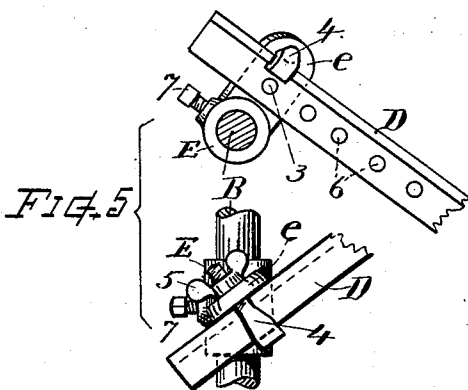
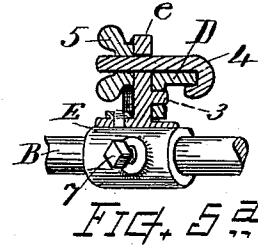
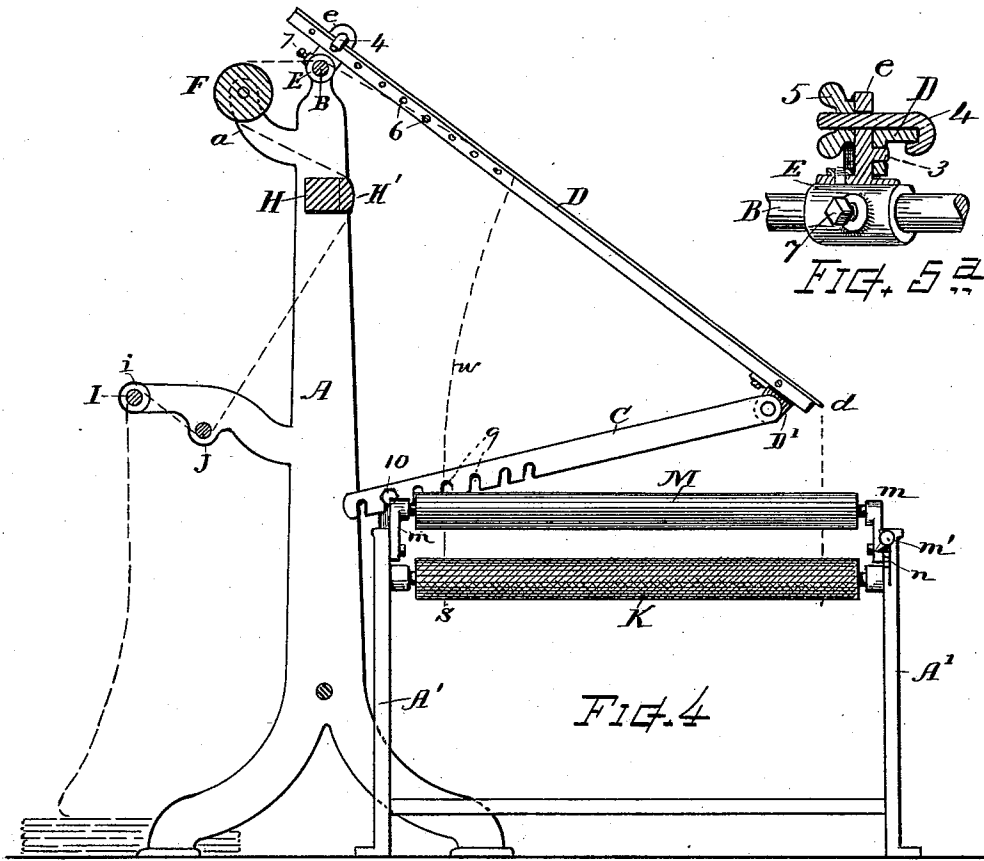

WITNESSES

*Ella P. Blenus*  
*Simon E. Kuea*

INVENTORS.

*Edwin T. Marble*  
*Edwin H. Marble*  
 By *Chas. H. Burling*  
*Attorney*

# UNITED STATES PATENT OFFICE.

EDWIN T. MARBLE AND EDWIN H. MARBLE, OF WORCESTER,  
MASSACHUSETTS.

MECHANISM FOR DOUBLING WEBS OF FABRIC LONGITUDINALLY.

**SPECIFICATION** forming part of Letters Patent No. 523,363, dated July 24, 1894.

Application filed December 23, 1893. Serial No. 494,516. (No model.)

*To all whom it may concern:*

Be it known that we, EDWIN T. MARBLE and EDWIN H. MARBLE, citizens of the United States, residing at Worcester, in the county of Worcester and State of Massachusetts, have  
5 invented a new and useful Improvement in Mechanisms for Doubling Webs of Fabric Longitudinally, of which the following, together with the accompanying drawings, is a  
10 specification, sufficiently full, clear, and exact to enable persons skilled in the art to which this invention appertains to make and use the same.

Our present invention relates to an improved construction and organization of mechanism for doubling webs of cloth or similar fabrics longitudinally, or edge to edge, as the fabric is continuously drawn forward through  
15 the machine; also, to the improved combination and arrangement of devices for spreading and smoothing the fabric as it passes to the doubling frame: the object of our invention being to render the doubling mechanism conveniently adjustable in a way and  
20 manner that will more perfectly adapt the mechanism to the condition and requirements of various kinds, qualities and weights of goods; for varying the tension at the respective sides of the folded fabric, and for properly doubling  
25 different widths of fabric.

Another object is to provide for the more efficient and satisfactory spreading and smoothing of the fabric as it passes to the doubling frame.

35 These objects we attain by mechanisms such as hereinafter explained and illustrated in the drawings, wherein—

Figure 1 is an elevation view of our improved mechanism. Fig. 2 is a bottom view  
40 of the vertex of the duplicator angle, showing the hinging of the brace-bar thereto. Fig. 3 is a sectional view showing a portion of the spreader-plate. Fig. 4 is a vertical section of the machine at line X X Fig. 1. Fig. 5 shows  
45 side and plan views of the attachment for securing and adjusting the upper end of the duplicator in connection with its support. Fig. 5<sup>a</sup> is a sectional view of the same, and Fig. 6 shows top and plan of the duplicator

brace and illustrates the manner of connecting and adjusting said brace.

Our improvements are more especially designed for use in connection with edge-stitching mechanism of the character described in Letters Patent No. 489,590, but are applicable  
55 to other machines wherein it is required to fold the fabric in similar manner longitudinally, or edge to edge.

The mechanism to which the fabric is carried after being doubled is not herein shown,  
60 as it forms no part of our present invention and may be of any suitable kind or structure.

In general construction our present apparatus comprises a tall frame or pair of standards, supporting between them the roll, bars  
65 and devices for guiding, spreading, or smoothing out the fabric; and a lower frame standing transversely to the plane of the spreading appliances; which lower frame supports the fold-laying roll, or guide beneath which  
70 the doubling fabric passes. Upon the upper part of said tall frame the broad end of a V-shaped duplicator or angular fold-forming frame is adjustably supported, disposed in  
75 position downwardly inclined from the top-bar toward the point or vertex and capable of varied inclination. Said duplicator is sustained at proper degree of inclination for attaining the most efficient action by means of  
80 an adjustably connected brace-bar hinged or suitably attached at or near the vertex or point of the duplicator, and supported at its other end in a manner that affords convenient adjustment to meet the conditions and  
85 requirements of different kinds, qualities and widths of fabric.

The particular features of our invention are hereinafter more definitely specified.

Referring to parts, A A' denote the supporting frames.

B indicates a top-bar or shaft mounted in bearings at the top of the frames A, and free to rock or move therein.

D denotes the duplicator for throwing the fabric into doubled or longitudinally folded  
90 form; said duplicator being formed of two bars connected together at their lower ends, at the vertex *d*, by a plate or hinge piece D',

(see Figs. 2 and 4,) and having their upper ends respectively connected with the top-bar B by attachments E that afford facility for ready adjustment in directions longitudinally of the bars.

The attachment E is preferably made as shown, (see Figs. 5 and 5<sup>a</sup>) and consists of a sleeve arranged upon and adjustable longitudinally on the bar B, and having an upwardly projecting flange or ear *e* inclined or adaptable to correspond to the angle of the duplicator D, and provided with a stud or pin 3 in the face thereof, against which said bar is clamped by a grip-bolt 4 and thumb-nut 5; the bar of the duplicator D being provided with a series of holes or recesses 6 for the reception of the stud 3 which prevents longitudinal slip of the bar when adjusted. The sleeve is provided with a set-screw 7 for confining it at any position on the top-bar B.

The vertex of the duplicator is supported by a central brace-bar C, one end of which is hinged to the plate D' and its other end is fitted with a series of recesses 9 that latch onto or engage with a stud 10 supported in the frame A' (see Figs. 1, 4 and 6). The available working length of the brace can be varied by placing its different notches or recesses 9 on the stud 10; and the vertex *d* of the duplicator D thereby raised or depressed; or, if supplemented by adjustment at the attachment E, carried in or out horizontally. The stud 10 is preferably made as a screw-bolt so that by screwing it into the ear A' of the frame it will clamp the bar C firmly against said ear. Under ordinary conditions, however, the brace-bar is simply latched onto the stud and can readily be lifted off and shifted when adjustment is desired.

F indicates a rotatable friction or drag-roll, mounted in suitable bearings *a* near the top of the frame A, parallel with the top-bar B, and provided on its end or journal with an adjustable friction-brake F' whereby the degree of frictional drag can be regulated.

H indicates a stationary beam supported upon and extending across the space between the uprights of frames A, parallel with and below the top-bar B and drag-roll F, and provided, near its ends, with spreader-plates H' having their faces formed into a series of diagonal outwardly inclined ribs or corrugations (see Figs. 1 and 3) that serve for spreading the fabric laterally toward the right and left as it is drawn over the face of the beam.

I and J indicate the horizontal guide-bars in the breast of the frame; preferably at a height of about four feet, more or less, from the floor. The bar I is as usual provided with edge-guiding collars *i*.

The fold-laying guide, or rough-faced roll K, beneath which the folded fabric passes as it is drawn from the angular duplicator, is arranged in well known manner. By means of said roll the two plies are laid together, selvage to selvage, to be delivered horizontally, as at W, or advanced to such mechanism as

may be employed for any further operation. The fabric can be drawn forward or advanced by feed-rolls L or any suitable well known means such as ordinarily employed in machinery of this class.

M indicates a bar or roller located between the duplicator angle and the guide-roll K and journaled on swinging arms or suitable bearings *m m* that afford backward and forward adjustment of said roller toward or from the central vertical plane of the duplicator. The purpose and operation of this roller is to give a degree of tension on the upper fold of fabric sufficient to equalize the tension on the under fold due to its passing outside, or on a larger circle about the roll K. The adjustment of the roll M permits the variation required, for controlling the slackness of upper fold when doubling fabrics of different weights or thickness; thereby rendering the mechanism more efficient and successfully operative for doubling a variety of fabrics. A latch lever *m'* and recessed arc *n*, or other means, is employed for adjusting and retaining the roll M.

In the operation the cloth or fabric passes over the bar I beneath the bar J, thence about the face of the spreader-beam H and over the drag-roll F and top-bar B to the downwardly inclined duplicator D whereby it is directed into folded form, and from thence down to and under the guide-roll K; from which it is carried forward in doubled condition to such place, or mechanism, as may in any instance be desired. In its passage the fabric is folded at the vertex *d* and its edges brought together from the divergent sides of the duplicator, as indicated by the dotted lines at *w*.

By making the bars D of the duplicator adjustable in connection with their supports, and the brace-bar adjustable in connection with its support in the manner described, we provide a mechanism that is readily adapted by such adjustments to the doubling of either wide or narrow fabrics, without changing the position or lines at which the selvage edges run, this being accomplished by extending or shortening the projection of the duplicator D over the roll K. Adjustment of the duplicator D at its heel or supported end is effected by loosening the nut 5 and bolt 4 sufficiently to release the recess 6 in the bar from the stud 3, and then bringing the bar to the position required, engaging the stud in the recess 6 and re-tightening the bolt and thumb-nut. The vertex of the duplicator D can also be raised or depressed by adjustment of the brace-bar C, thus varying the inclination of the plane of the duplicator so as to give more or less tension at either side to the folding fabric, and to accommodate the peculiarities in folding of different qualities and weights of fabrics. This feature is of practical importance and advantage in the successful doubling of a variety of fabrics.

By constructing and arranging the spreader-beam, guiding bars and drag-roll as shown

and combining the same with the V shaped duplicator, as described, we produce a mechanism whereby the web of fabric is extended and freed from wrinkles in a very efficient and practical manner and delivered for doubling in a manner to give a true and perfect fold.

The sides of the duplicator D may, in some instances, be non-adjustably connected to the plate D', as in Fig. 1, in lieu of being hinged at the vertex *d* and made rigid by the adjustable attachment, as shown by Fig. 2.

What we claim, and desire to secure by Letters Patent, is—

1. In a machine for doubling fabrics longitudinally, the combination, substantially as described, of the rocking support, the triangular duplicator having converging side-bars, their inner ends joined with a point-plate and their outer ends connected with said rocking-support, attaching devices therefor that afford longitudinal and transverse adjustment of said side-bars, the center-brace sustaining the vertex of said duplicator, one end of said brace hinged to said point-plate, its other end fitted with a series of recesses or notches, and a stud fixed on the frame for engaging said recesses; whereby said center-brace is connected with its support to afford instant detachment thereof for adjustment of the duplicator, for the purpose set forth.

2. In a fabric doubling mechanism, the V-shaped duplicator, and a center brace hinged thereto, each of the side-bars of said duplicator and said brace being provided with facili-

ties for their longitudinal independent adjustment in connection with their supports; whereby said duplicator is adapted for variation in its extension and also in its position of inclination, for the purpose set forth.

3. The combination, substantially as described, with the duplicator, its side bars being fitted with series of holes or recesses near their outer ends, and the top-bar over which the fabric is delivered to said duplicator, of the bar-clamping attachment adjustable on said top-bar and provided with an ear-plate for receiving said side-bar and carrying a stud that engages the recess therein, the grip-bolt that retains the bar to said ear-plate, and the adjustable supporting brace connected with said duplicator, for the purposes set forth.

4. The combination, with the V-shaped duplicator, and the guide-roll to which the fabric passes from the inclined sides of said duplicator; of a roll or bar M disposed between said duplicator and guide-roll, and mounted in bearings that are adjustable toward and from a vertical plane central to the duplicator, and means for effecting and maintaining the adjustment of the same, for the purpose set forth.

Witness our hands this 19th day of December, A. D. 1893.

EDWIN T. MARBLE.  
EDWIN H. MARBLE.

Witnesses:

CHAS. H. BURLEIGH,  
ELLA P. BLENUS.