

(19) World Intellectual Property Organization
International Bureau



(43) International Publication Date
30 January 2003 (30.01.2003)

PCT

(10) International Publication Number
WO 03/007879 A2

- (51) International Patent Classification⁷: **A61K** 3610 Winterfield Run, Fort Wayne, IN 46804 (US).
SCHWARTZ, Herbert, Eugene [US/US]; 11702 Pennat Run, Fort Wayne, IN 46845 (US).
- (21) International Application Number: PCT/US02/22411
- (22) International Filing Date: 15 July 2002 (15.07.2002) (74) Agent: **COFFEY, William, R.**; Barnes & Thornburg, 11 South Meridian Street, Indianapolis, IN 46204 (US).
- (25) Filing Language: English (81) Designated States (*national*): AE, AG, AL, AM, AT, AU, AZ, BA, BB, BG, BR, BY, BZ, CA, CH, CN, CO, CR, CU, CZ, DE, DK, DM, DZ, EC, EE, ES, FI, GB, GD, GE, GH, GM, HR, HU, ID, IL, IN, IS, JP, KE, KG, KP, KR, KZ, LC, LK, LR, LS, LT, LU, LV, MA, MD, MG, MK, MN, MW, MX, MZ, NO, NZ, OM, PH, PL, PT, RO, RU, SD, SE, SG, SI, SK, SL, TJ, TM, TN, TR, TT, TZ, UA, UG, US, UZ, VN, YU, ZA, ZM, ZW.
- (26) Publication Language: English (84) Designated States (*regional*): ARIPO patent (GH, GM, KE, LS, MW, MZ, SD, SL, SZ, TZ, UG, ZM, ZW), Eurasian patent (AM, AZ, BY, KG, KZ, MD, RU, TJ, TM), European patent (AT, BE, BG, CH, CY, CZ, DE, DK, EE, ES, FI, FR, GB, GR, IE, IT, LU, MC, NL, PT, SE, SK, TR), OAPI patent (BF, BJ, CF, CG, CI, CM, GA, GN, GQ, GW, ML, MR, NE, SN, TD, TG).
- (30) Priority Data:
60/305,786 16 July 2001 (16.07.2001) US
60/388,724 14 June 2002 (14.06.2002) US
- (71) Applicant (*for all designated States except US*): **DEPUY PRODUCTS, INC.** [US/US]; 700 Orthopaedic Drive, Warsaw, IN 46581 (US).
- (72) Inventors; and (75) Inventors/Applicants (*for US only*): **PLOUHAR, Pamela, Lynn** [US/US]; 17411 Battles Road, South Bend, IN 46614 (US). **MALAVIYA, Prasanna** [IN/US];

[Continued on next page]

(54) Title: CARTILAGE REPAIR AND REGENERATION SCAFFOLD AND METHOD

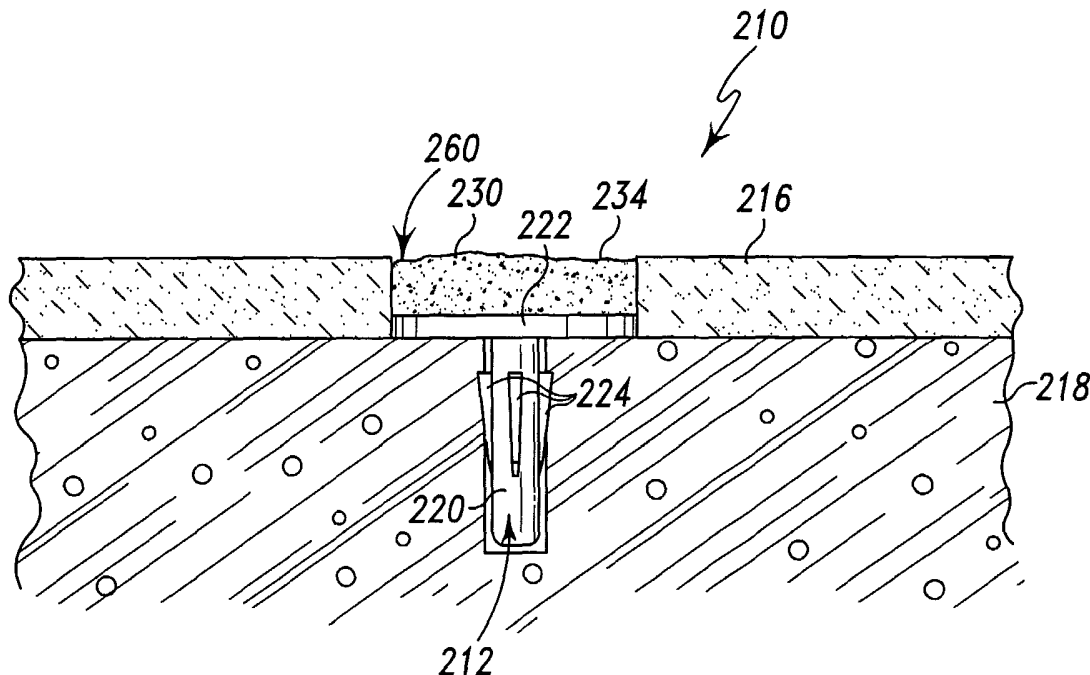

(57) Abstract: A method for the repair of a cartilaginous tissue defect and a cartilage repair device (20, 210) are disclosed. In the method for the repair of a cartilaginous tissue defect (14), a device (20, 210) comprising a synthetic polymer (230) is implanted into a space (16) subsequent to removal of the defect (14), and a biological lubricant is administered at the site of the defect (14). The device (20, 210) comprises a synthetic polymer (230) and a biological lubricant (234).



WO 03/007879 A2



Published:

— *without international search report and to be republished upon receipt of that report*

For two-letter codes and other abbreviations, refer to the "Guidance Notes on Codes and Abbreviations" appearing at the beginning of each regular issue of the PCT Gazette.

CARTILAGE REPAIR AND REGENERATION SCAFFOLD AND METHOD

CROSS REFERENCE TO RELATED APPLICATIONS

Cross reference is made to co-pending U.S. patent applications Serial
5 No. XX/XXX,XXX entitled "Meniscus Regeneration Device and Method" (Attorney
Docket No. 265280-71141, DEP-745); Serial No. XX/XXX,XXX entitled "Devices
from Naturally Occurring Biologically Derived Materials" (Attorney Docket No.
265280-71142, DEP-748); Serial No. XX/XXX,XXX entitled "Cartilage Repair
Apparatus and Method" (Attorney Docket No. 265280-71143, DEP-749); Serial No.
10 XX/XXX,XXX entitled "Unitary Surgical Device and Method" (Attorney Docket No.
DEP-750); Serial No. XX/XXX,XXX entitled "Hybrid Biologic/Synthetic Porous
Extracellular Matrix Scaffolds" (Attorney Docket No. 265280-71144, DEP-751);
Serial No. XX/XXX,XXX entitled "Cartilage Repair and Regeneration Device and
Method" (Attorney Docket No. 265280-71145, DEP-752); Serial No. XX/XXX,XXX
15 entitled "Porous Extracellular Matrix Scaffold and Method" (Attorney Docket No.
265280-71146, DEP-747); and Serial No. XX/XXX,XXX entitled "Porous Delivery
Scaffold and Method" (Attorney Docket No. 265280-71207, DEP-762), each of
which is assigned to the same assignee as the present application, each of which is
filed concurrently herewith, and each of which is hereby incorporated by reference.
20 Cross reference is also made to U.S. Patent Application Serial No. 10/172,347 entitled
"Hybrid Biologic-Synthetic Bioabsorbable Scaffolds" which was filed on June 14,
2002, which is assigned to the same assignee as the present application, and which is
hereby incorporated by reference.

25 BACKGROUND OF THE INVENTION

Articular cartilage is a type of hyaline cartilage that lines the surfaces
of the opposing bones in a diarthrodial joint (e.g., knee, hip, shoulder, etc.). Articular
cartilage provides a near-frictionless articulation between the bones, while also
functioning to absorb and transmit the compressive and shear forces encountered in
30 the joint. Further, since the tissue associated with articular cartilage is aneural, these
load absorbing and transmitting functions occur in a painless fashion in a healthy
joint.

-2-

Fibrocartilage is found in diarthrodial joints, symphyseal joints, intervertebral discs, articular discs, as inclusions in certain tendons that wrap around a pulley, and at insertion sites of ligaments and tendons into bone. Made of a mixture of collagen type I and type II fibers, fibrocartilage can also be damaged, causing pain in the affected joint. It is understood for purposes of this application that the term “cartilage” includes articular cartilage and fibrocartilage.

When cartilage tissue is no longer healthy it can cause debilitating pain in the joint. For example, articular cartilage health can be affected by disease, aging, or trauma, all of which primarily involve a breakdown of the matrix consisting of a dense network of proteoglycan aggregates, collagen fibers, and other smaller matrix proteins. Tissue cells are unable to induce an adequate healing response because they are unable to migrate, being enclosed in lacunae surrounded by a dense matrix. Further, since the tissue is avascular, initiation of healing by circulating cells is limited. Similarly, damage or degeneration of knee fibrocartilage i.e., the menisci, is a common occurrence. A damaged or degenerated meniscus has little ability to heal or repair itself because the pathology frequently occurs in the avascular part of the tissue.

Several articular cartilage repair strategies have been attempted in the past. These include surgical techniques such as microfracturing or performing abrasion arthroplasty on the bone bed to gain vascular access, and hence, stimulate extrinsic repair in the defective region. The long-term outcome of these techniques, however, has been known to result in mechanically inferior fibrocartilagenous tissue.

Another surgical technique is mosaicplasty or osteochondral autograft transfer system (OATS). In this case, cylindrical plugs of healthy articular cartilage from a low-load bearing region of the knee are taken and transplanted into the defective region. This technique, however, can result in excessive donor-site morbidity and associated pain. Additionally, surgeons have reported that the gaps between the round transplants are frequently filled with fibrocartilage which can eventually erode away, thus potentially compromising the integrity of repair throughout the affected area.

The only FDA-approved cartilage treatment product in the market involves autologous chondrocyte implantation (CartiCel™). Autologous chondrocyte implantation involves performing an initial biopsy of healthy cartilage from the

-3-

patient, isolating the cells from the tissue, expanding the cells in vitro by passaging them in culture, and then reintroducing the cells into the defective area. The cells are retained within the defect by applying a periosteal tissue patch over the defect, suturing the edges of the patch to the host tissue, and then sealing with fibrin glue.

5 The efficacy of this expensive procedure, however, has recently been put into question by studies that have shown that only a few of the injected cells are retained within the defect and that they may not significantly contribute to the repair process. The healing observed is similar to that observed with microfracture or abrasion of the bone bed, suggesting that it is the preparation of the bone bed and not the introduction
10 of the cells that facilitates the healing process.

Tissue engineering strategies for healing cartilage are being investigated by several academic and commercial teams and show some promise. One approach primarily involves using a biocompatible biologic or synthetic scaffold to deliver cells or stimulants to the defect site. The scaffold material can be a purified
15 biologic polymer in the form of a porous scaffold or a gel (purified collagens, glycoproteins, proteoglycans, polysaccharides, or the like in various combinations) or porous scaffolds of synthetic biodegradable polymers (PLA, PGA, PDS, PCL, or the like, in various combinations). Several challenges remain with this approach, however. Some of these challenges include retention of the active stimulant at the
20 defect site, inability to control the rate of release of the stimulant (resulting in tissue necrosis due to overdose), and cytotoxicity of the cells due to the degradation by-products of the synthetic polymers.

In another technique, various collagen scaffolds have been used to provide a scaffold for repair and regeneration of damaged cartilage tissue. U.S.
25 Patent No. 6,042,610 to ReGen Biologics, hereby incorporated by reference, discloses the use of a device to regenerate meniscal fibrocartilage. The disclosed device comprises a bioabsorbable material made at least in part from purified collagen and glycosaminoglycans (GAG). Purified collagen and glycosaminoglycans are co-lyophilized to create a foam and then cross-linked to form the device. The device can
30 be used to provide augmentation for a damaged meniscus. Related U.S. Patents Nos. 5,735,903, 5,479,033, 5,306,311, 5,007,934, and 4,880,429 also disclose a meniscal augmentation device for establishing a scaffold adapted for ingrowth of meniscal fibrochondrocyts.

-4-

It is also known to use naturally occurring extracellular matrices (ECMs) to provide a scaffold for tissue repair and regeneration. One such ECM is small intestine submucosa (SIS). SIS has been described as a natural biomaterial used to repair, support, and stabilize a wide variety of anatomical defects and traumatic injuries. See, for example, Cook® Online New Release provided by Cook Biotech at “www.cookgroup.com”. The SIS material is reported to be a naturally occurring collagenous matrix derived from porcine small intestinal submucosa that models the qualities of its host when implanted in human soft tissues. Further, it is taught that the SIS material provides a natural matrix with a three-dimensional structure and biochemical composition that attracts host cells and supports tissue remodeling. SIS products, such as Oasis material and Surgisis material, are commercially available from Cook Biotech, Bloomington, IN.

An SIS product referred to as RESTORE Orthobiologic Implant is available from DePuy Orthopaedics, Inc. in Warsaw, Indiana. The DePuy product is described for use during rotator cuff surgery, and is provided as a resorbable framework that allows the rotator cuff tendon to regenerate itself. The RESTORE Implant is derived from porcine small intestine submucosa that has been cleaned, disinfected, and sterilized. Small intestine submucosa (SIS) has been described as a naturally occurring ECM composed primarily of collagenous proteins. Other biological molecules, such as growth factors, glycosaminoglycans, etc., have also been identified in SIS. See Hodde et al., *Tissue Eng.* 2(3): 209-217 (1996); Voytik-Harbin et al., *J. Cell Biochem.*, 67:478-491 (1997); McPherson and Badylak, *Tissue Eng.*, 4(1): 75-83 (1998); Hodde et al., *Endothelium*, 8(1):11-24 (2001); Hodde and Hiles, *Wounds*, 13(5): 195-201 (2001); Hurst and Bonner, *J. Biomater. Sci. Polym. Ed.*, 12(11) 1267-1279 (2001); Hodde et al., *Biomaterial*, 23(8): 1841-1848 (2002); and Hodde, *Tissue Eng.*, 8(2): 295-308 (2002), all of which are incorporated by reference herein. During seven years of preclinical testing in animals, there were no incidences of infection transmission from the implant to the host, and the RESTORE Implant has not decreased the systemic activity of the immune system. See Allman et al., *Transplant*, 17(11): 1631-1640 (2001); Allman et al., *Tissue Eng.*, 8(1): 53-62 (2002).

While small intestine submucosa is available, other sources of submucosa are known to be effective for tissue remodeling. These sources include,

-5-

but are not limited to, stomach, bladder, alimentary, respiratory, or genital submucosa, or liver basement membrane. See, e.g., U.S. Patents Nos. 6,171,344, 6,099,567, and 5,554,389, hereby incorporated by reference. Further, while SIS is most often porcine derived, it is known that these various submucosa materials may be derived from non-porcine sources, including bovine and ovine sources. Additionally, other collagenous matrices are known, for example lamina propria and stratum compactum.

It is also known to promote cartilage growth using glycosaminoglycans (GAG), such as hyaluronic acid (HA), dermatan sulfate, heparan sulfate, chondroitin sulfates, keratin sulfate, etc. See, e.g., U.S. Patents Nos. 6,251,876 and 6,288,043, hereby incorporated by reference. GAGs are naturally found mostly in the extracellular matrix and on the cell surface as proteoglycans. These macromolecules are secreted by cells and play a role in both signal transduction and storage of some growth factors. In addition to the biological functions, the viscoelastic properties of GAGs provide a mechanical function by providing lubrication within a joint, to decrease friction. Hyaluronic acid is a natural component of the extracellular matrix of most cartilage tissues. HA is a linear polymer made up of repeating GAG disaccharide units of D-glucuronic acid and N-acetylglycosamine in $\beta(1-3)$ and $\beta(1-4)$ linkages. Illustratively HA can have a molecular weight ranging from about 300,000 kDa to about 6,000,000 kDa and can be uncrosslinked, naturally crosslinked, or crosslinked using mechanical, chemical, or enzymatic methods. The effect of treating extrasynovial tendons with HA and chemically modified HA has also been studied with reference to tendon gliding resistance and tendon adhesions to surrounding tissue after repair. Momose, Amadio, Sun, Chunfeng Zhao, Zobitz, Harrington and An, "Surface Modification of Extrasynovial Tendon by Chemically Modified Hyaluronic Acid Coating," J. Biomed. Mater. Res. 59: 219-224 (2002).

SUMMARY OF THE INVENTION

It has been found that the combination of a biocompatible scaffold and HA produces a synergistic effect. Healing rates and/or quality of healing is better than the healing expected from additive effects of the scaffold or HA alone. Moreover, it has been found that retention of HA at the defect site is not problematic and co-administration of the scaffold and HA does not require HA to be cross-linked to the scaffold material. Thus, the present invention provides methods for the repair

-6-

of damaged or diseased cartilaginous tissue, wherein a biocompatible scaffold and HA are co-administered to the cartilaginous tissue defect.

In addition to HA, GAGs such as dermatan sulfate, heparan sulfate, chondroitin sulfate, and keratan sulfate are also expected to be usable with the present invention. As used herein, "biological lubricant" is used to identify the
5 aforementioned materials and others such as synovial fluid and components thereof, including mucinous glycoproteins (for example lubricin), tribonectins, articular cartilage superficial zone proteins, surface-active phospholipids, and lubricating glycoproteins I, II; vitronectin; and rooster comb hyaluronate (e.g., commercially
10 available HEALON®, (Pharmacia Corporation, Peapack, New Jersey), for example, and mixtures thereof. Such materials serve both a biological and a mechanical function: they play a biological role in directly and indirectly influencing cellular behavior by being involved in signal transduction alone or in conjunction with other extracellular matrix components such as growth factors, glycoproteins, collagens etc.,
15 and a mechanical role in providing lubrication. Thus, the use of the expression "biological lubricant" is intended to encompass materials that provide some biological function (influencing cellular behavior) and some mechanical function (lubrication).

It is believed that some commercially available biological lubricants can be used in the practice of the present invention. Examples of such commercially
20 available lubricants include: ARTHREASE™ high molecular weight sodium hyaluronate, available in Europe from DePuy Orthopaedics, Inc. of Warsaw, Indiana; SYNVISIC® Hylan G-F 20, manufactured by Biomatrix, Inc., of Ridgefield, New Jersey, and distributed by Wyeth-Ayerst Pharmaceuticals of Philadelphia, Pennsylvania; and HYLAGAN® sodium hyaluronate, available from Sanofi-
25 Synthelabo, Inc., of New York, New York. The expressions "HA", "GAG", and "biological lubricant" are intended to encompass these materials. It should be understood that there may be other salts of hyaluronic acid that may be used in the present invention, and the expressions "HA", "GAG", and "biological lubricant" should be understood to encompass such salts.

30 The three-dimensional biologic or synthetic scaffolds may be provided in the form of a fibrous non-woven or foam material. The scaffold preferably has interconnecting pores or voids to facilitate the transport of nutrients and/or invasion of cells into the scaffold. The interconnected voids range in size, for example, from

-7-

about 20 to 400 microns, illustratively 50 to 250 microns, depending on the application. The range of the void size in the construct can be manipulated by changing process steps during construct fabrication. See Serial No. XX/XXX,XXX entitled "Porous Delivery Scaffold and Method" (Attorney Docket No. 265280-5 71207, DEP-762), already incorporated by reference. The foam optionally may be formed around a reinforcing material, for example, a knitted mesh or an ECM layer. See U.S. Patent Application Serial No. 10/172,347 entitled "Hybrid Biologic-Synthetic Bioabsorbable Scaffolds" which was filed on June 14, 2002, already incorporated by reference. The fibers used to make the scaffold can be made of any 10 biocompatible material, including bioabsorbable materials such as polylactic acid (PLA), polyglycolic acid (PGA), polycaprolactone (PCL), polydioxanone (PDO), trimethylene carbonate (TMC), polyvinyl alcohol (PVA), copolymers or blends thereof, or combinations of synthetic and biologic polymers. See also, Serial No. XX/XXX,XXX entitled "Hybrid Biologic/Synthetic Porous Extracellular Matrix 15 Scaffolds" (Attorney Docket No. 265280-71144, DEP-751). The biologic polymers may comprise ECM, particularly comminuted ECM. In an exemplary embodiment, the fibers that comprise scaffold are formed of a polylactic acid and polyglycolic acid copolymer at a 95:5 mole ratio.

In one embodiment of the present invention, a method is provided 20 wherein the scaffold material is implanted into the defect. The biological lubricant, which can be a GAG or HA for example, is administered separately, either at the time of surgery or via injection subsequent to closure of the incision. Optionally, a series of additional injections may be administered over a period of time. In either case, the injection may be made intra-articularly.

25 In another embodiment, a method is provided wherein the scaffold material and the biological lubricant are administered to the defect together. The scaffold material may be saturated with the biological lubricant at the time of surgery. Alternatively, the scaffold material may be saturated with the biological lubricant at the time of manufacture, and may be packaged together. Optionally, a series of 30 additional injections may be administered in this method as well.

In still another embodiment, an implantable device is provided comprising a scaffold material saturated with a biological lubricant.

-8-

BRIEF DESCRIPTION OF THE DRAWINGS

Fig. 1 is a diagrammatical view showing a tibial platform with a typical meniscus structure on the platform and a portion of the meniscus removed for illustration purposes, the tibia platform being below the condyles of the femur;

5 Fig. 2 is a view looking down at the tibial platform and showing diagrammatically the insertion of a scaffold to replace the portion of the meniscus removed;

Fig. 3 shows the inserted scaffold in a position to be attached to the portions of the meniscus remaining after the injured portion is removed;

10 Fig. 4 is a sectional view taken from Fig. 3 along the lines 4-4;

Fig. 5 is a perspective view showing an open wedge-shaped device comprising an upper panel and a lower panel angularly separated to define an apex portion and a base portion;

15 Fig. 6 shows a wedge shaped device prior to folding with a pocket shown in imaginary lines formed in the device;

Fig. 7 shows a further step in the process in making the device shown in Fig. 6 to produce a filled, wedge-shaped device;

Fig. 8 is a top view of a ECM device used for the repair of a meniscal defect and having barbs for attachment;

20 Fig. 9 is a top view of a device similar to that shown in Fig. 1, except having sutures for attachment;

Fig. 10 is a perspective, partially cut-away view of a meniscus with the device of Fig. 1 inserted into the meniscus;

25 Fig. 11 is a cross sectional view of a cartilage repair device implanted in subchondral bone, note that the anchor is shown in elevation rather than cross section for clarity of description; and

Fig. 12 is a cross sectional view of a cartilage repair device which uses an alternative embodiment of an anchor.

30 DETAILED DESCRIPTION

While the invention is susceptible to various modifications and alternative forms, specific embodiments thereof have been shown by way of example in the drawings and will herein be described in detail. It should be understood,

however, that there is no intent to limit the invention to the particular forms disclosed, but on the contrary, the intention is to cover all modifications, equivalents, and alternatives falling within the spirit and scope of the invention as defined by the appended claims.

5 Referring to Fig. 1, it will be seen that a tibial platform 10 below the condyles 12 of a knee support a meniscus 11 from which an illustrative defective portion 14 is removed to leave a wedge-shaped space 16. In the removal process, the surgeon will often leave an outer rim 18 of the meniscus. The meniscus provides a large surface of articulation between the otherwise incongruent surfaces of the tibia
10 platform or plateau and the femur condyles (such indicated at 12). The meniscus serves to reduce contact stresses and wear in the knee joint.

The portion 14 removed from the structure shown in Fig. 1 includes a portion of the original meniscus which was within the avascular zone, particularly the radially inner portion, and may include a portion of the original meniscus which was
15 within the vascular zone.

Fig. 2 shows how a scaffold device 20 may illustratively be inserted into the space 16 to be against the outer rim 18. This illustrative scaffold 20 is shown in Figs. 3 and 4 in position filling the space 16 and against the rim 18 left by the surgeon. Fig. 4 shows the scaffold as comprising an upper cover or upper panel 22
20 and a lower cover or lower panel 24. These panels 22, 24, which may illustratively be angularly related, will define an internal space 26 between the covers. Internal space 26 optionally may be filled with a biological material, a biological structure, or a synthetic structure providing a framework for regeneration of the meniscus into the space 16. Illustratively, panels 22, 24 may be made from woven or nonwoven mats of
25 synthetic polymer or synthetic/biologic polymers. Alternatively, scaffold 20 may be constructed by forming the synthetic or synthetic/biologic polymers in a mold, or by sculpting a block of the polymer into the proper shape.

The scaffolds may comprise synthetic polymers such as polylactic acid (PLA), polyglycolic acid (PGA), polycaprolactone (PCL), polydioxanone (PDO),
30 trimethylene carbonate (TMC), polyvinyl alcohol (PVA), and copolymers and blends thereof. The synthetic polymers may be provided as textiles with woven, knitted, warped knitted, nonwoven, braided, and foamed structures, and illustratively may be imbedded in ECM material, as in copending U.S. Patent Application Serial No.

-10-

10/172,347 entitled "Hybrid Biologic-Synthetic Bioabsorbable Scaffolds" which was filed on June 14, 2002, or may be provided as foams with or without ECM materials, as in copending U.S. Patent Application Serial No. XX/XXX,XXX entitled "Hybrid Biologic/Synthetic Porous Extracellular Matrix Scaffolds" (Attorney Docket No. 5 265280-71144, DEP-751). Thus, the scaffold may be made of biocompatible polymers, with or without a biologic component, and may be provided in a variety of woven, knitted, nonwoven, braided formed, or molded, or other configurations.

Scaffold 20 may be inserted, for example, in arthroscopic surgery through portals provided in the outer anterior surface of the knee opening into the 10 knee cavity between the condyles 12 and the tibial platform 10. However, any surgical procedure to insert a device into damaged cartilage is within the scope of the present invention. Illustratively, the upper cover 22 of the scaffold 20 may serve as a bearing surface for the condyle 12 disposed thereabove and be subjected to the compression and stress forces involved in articulation of the knee. The condyle will 15 move upon the upper surface of the cover 22.

Turning to Figs. 5, 6 and 7, it will be seen that an illustrative device is somewhat diagrammatically illustrated. The illustrative device 30 includes an upper panel 32 and a lower panel 34 defining a wedge-shaped device having a base portion 36 and an apex portion 38. Fig. 6 suggests that the device may include a formed 20 wedge-shaped cavity 39 (illustrated in phantom) and that the device may be folded about a fold line 40 to provide a device such as indicated at 42 in Fig. 7. While the Fig. 5 device 30 suggests an open wedge-shaped design, the device 42 in Fig. 7 suggests that, between the upper and lower panels 32, 34 a mass of biological material may be disposed. In Fig. 6, a plurality of tacks 44 are shown attached to one of the 25 two panels of the device to be used for securing the device to surrounding tissue in the knee. The panels 32, 34 may be trimmed to the desired wedge shape.

Referring now to Figs. 8-10, there are shown scaffolds similar to those shown in Figs. 6-7, except that device 100 need not be wedge shaped. Scaffold 100 comprises panels 102 and 104, with a pillow 106 of biological or synthetic material 30 shaped to fill the void in meniscus 111 left after a partial menisectomy, as illustrated in Fig. 1. The pillow is placed between panels 102 and 104. In the illustrative embodiment, pillow 106 is smaller than panels 102 and 104, and wing portions 105 of panels 102 and 104 extend beyond pillow 106.

-11-

As shown in Fig. 8, scaffold 100 may be provided with barbed darts 112 extending from wings 105. A needle or similar device would be used to push the barbed darts 112 into or through the meniscus to secure scaffold 100 to the meniscus. Barbed darts may be made of any biocompatible material sufficiently rigid to secure scaffold 100 to the meniscus. Barbed darts 112 may be provided integrally with scaffold 100 or may be added by the surgeon prior to insertion of the device.

The scaffold 100 illustrated in Fig. 9 is similar to the scaffold shown in Fig. 8, except that instead of barbed darts, the scaffold of Fig. 9 is provided with sutures 113. The scaffold of Fig. 9 may be affixed to the meniscus in a manner similar to that of the scaffold of Fig. 8. A needle or similar device would be used to push the sutures 113 through the meniscus. As illustrated in Fig. 10, the sutures may be tied together on the outside of the meniscus to form knots 120 that secure scaffold 100 in place.

While in the various embodiments discussed herein, tacks and sutures have been shown for anchoring the devices, it will be appreciated that the devices may be anchored by any other method at the choice of the surgeon.

Figs. 11 and 12 illustrate several scaffolds that can be used in conjunction with a biological lubricant for cartilage repair. Referring now to Fig. 11, a cartilage repair device 210 is provided for repairing damaged or diseased cartilage. The device 210 includes an anchor 212 which is anchored or otherwise positioned in an opening formed in both a section of native cartilage 216 and the underlying subchondral bone 218. The anchor 212 is configured to be secured in an area from which damaged, diseased, or destroyed native cartilage and possibly bone have been removed. The anchor 212 includes an elongated central body portion 220 and a head portion 222. The body portion 220 extends downwardly from a lower surface of the head portion 222. As shown in Fig. 11, the body portion 220 may have a number of barbs 224 extending therefrom for engaging the sidewalls of the opening formed in the bone 218. In the illustrative embodiment described herein, the barbs 224 extend radially outwardly and are inclined slightly toward the head portion 222 of the anchor 212.

The cartilage repair device 210 also includes a plug 226. The plug 226 is secured to the anchor 212. Specifically, the plug 226 is secured to the upper surface of the head portion 222 of the anchor 212. The plug 226 allows for

-12-

communication across the removed portion (i.e., the portion of the native cartilage 216 from which the damaged or diseased cartilage has been removed) and the adjacent healthy cartilage. As such, the plug 226 functions as a chondrogenic growth-supporting matrix for promoting a positive cellular response in an effort to achieve articular cartilage regeneration.

The anchor 212 of the cartilage repair device 210 may be constructed of numerous types of synthetic or naturally occurring materials. For example, the anchor 212 may be constructed with a bioabsorbable polymer. Examples of such polymers include: polyesters of [alpha]-hydroxycarboxylic acids, such as poly(L-lactide) (PLLA), polyglycolide (PGA); poly-p-dioxanone (PDS); polycaprolactone (PCL); and any other bioresorbable and biocompatible polymer, co-polymer or mixture of polymers or co-polymers that are commonly used in the construction of prosthetic implants. Moreover, the anchor 212 may be constructed with a naturally occurring material such as a naturally occurring ECM (e.g., SIS). In such a case, the head portion 222 and body portion 220 of the anchor 212 may be configured as monolithic structures formed from naturally occurring ECM which is cured to be rigid and hardened to facilitate attachment to the bone 218. As such, it should be appreciated that the ECM material from which the anchor 212 is fabricated is cured to produce a structure which possesses the necessary hardness and toughness to allow the anchor 212 to be driven into bone tissue (i.e., the subchondral bone 218). See U.S. Patent Application Serial No. XX/XXX,XXX entitled "Devices from Naturally Occurring Biologically Derived Materials" (Attorney Docket No. 265280-71142, DEP-748), already incorporated by reference. It should be understood that the material selected for the anchor 212 may also comprise mixtures or composites of materials. For example, the anchor 212 could comprise both a polymer and ECM material.

As mentioned above, the plug 226, which is fixed to the anchor 212, functions as a chondrogenic growth-supporting matrix for promoting vascular invasion and cellular proliferation in an effort to achieve articular cartilage regeneration. A central body 230 of the plug 226 is configured as a porous structure of biodegradable material. When anchored to a defective area of cartilage, cells can migrate into and proliferate within the plug 226, biodegrade the plug 226 while, at the same time, synthesize new and healthy tissue to heal the defective area. The plug 226

-13-

may be made out of a nonwoven or foam scaffold of synthetic or synthetic/biologic fibers with the desired porosity and material density. Specifically, the material density and/or porosity of the plug 226 may be varied to control cell migration and proliferation. The cells can migrate from adjacent tissue or from synovial fluid. The fibers from which the plug 226 is constructed also may be formed to have a structural rigidity sufficient to withstand the compression and shear stress to which the cartilage 216 is subjected. As such, the porous material from which the plug 226 is constructed should have the structural rigidity necessary to bear the forces associated with the other bone.

One particularly useful material for fabricating the plug 226 is a porous scaffold or "foam" composed of synthetic fibers or a combination of synthetic fibers and naturally occurring ECM. Both the material density and the pore size of the foam plug 226 may be varied to fit the needs of a given plug design. Such foams may be fabricated by lyophilizing (i.e., freeze-drying) the fibers suspended in water. The material density and pore size of the resultant foam may be varied by controlling, among other things, the rate of freezing of the fiber suspension and/or the amount of water or moisture content in the fiber suspension at the on-set of the freezing process. See U.S. Patent Application Serial No. XX/XXX,XXX entitled "Cartilage Repair Apparatus and Method" (Attorney Docket 265280-71143, DEP-7490 and Serial No. XX/XXX,XXX entitled "Porous Extracellular Matrix Scaffold and Method" (Attorney Docket 265280-71146, DEP-747), already incorporated by reference.

Referring now to Fig. 12, there is shown another embodiment of a cartilage repair device (hereinafter referred to with reference numeral 410). The cartilage repair device 410 is somewhat similar to the cartilage repair device 210. As such, the same reference numerals are used in Fig. 12 to identify components which have previously been discussed, with additional discussion thereof being unwarranted. The cartilage repair device 410 includes an anchor 412 which is used in lieu of the anchor 212 described in regard to Fig. 11. In particular, in the embodiment shown in Fig. 12, the plug 226 is positioned in an osteochondral defect 414 without the use of a bottom-mounted anchor (i.e., the anchor 212 of Fig. 11). Similarly to as described above, the plug 226 is constructed out of synthetic fibers or a combination of synthetic fibers and naturally occurring ECM (e.g., SIS) having a desired porosity and material density.

-14-

The plug 226 is retained in the hole formed in the cartilage 216 and protected from *in vivo* forces by an annular shaped anchor 412. The anchor 412 may be provided in many different configurations which allow it to be press fit or otherwise anchored into the subchondral bone 218. For example, as shown in Fig. 12, the anchor 412 may be “bottle cap”-shaped so as to allow the anchor 412 to be press fit or otherwise secured into an annular groove 416 formed in the subchondral bone 218. The groove may be formed and the anchor may be shaped as described and shown in Patent Cooperation Treaty publication WO 01/39694 A2, published 7 June 2001 entitled “Fixation Technology”, the complete disclosure of which is incorporated by reference herein. Alternatively, the anchor 412 may be mechanically secured to the subchondral bone 218 by use of adhesive or other types of anchoring structures (e.g., barbs).

The anchor 412 of the cartilage repair device 410 may be constructed from numerous types of synthetic or naturally occurring materials. For example, the anchor 212 may be constructed with a bioabsorbable polymer such as PLLA, PGA, PDS, PCL, or any other such bioabsorbable polymer which is commonly used in the construction of prosthetic implants. Moreover, the anchor 412 may be constructed from a naturally occurring material such as a naturally occurring ECM (e.g., SIS) that is cured or otherwise fabricated to be rigid and hardened to facilitate attachment to the bone in the same manner as described above in regard to the anchor 212 and/or the plug 226 of Fig. 11.

The biological lubricant, illustratively a GAG or HA for example, is administered separately, either at the time of surgery or via injection subsequent to closure of the incision. Optionally, a series of additional injections may be administered over a period of time. In either case, the injection may be made intra-articularly. Alternatively, the scaffold can be saturated with the biological lubricant. In another embodiment, the biological lubricant can be crosslinked to the scaffold structure. As shown in Fig. 11, the biological lubricant 234 is applied to the surface of the plug 226.

It is expected that the teachings of the present invention may also be advantageously combined with the teachings of the following U.S. Patent Applications filed concurrently herewith and which are incorporated by reference herein: Serial No. XX/XXX,XXX entitled “Devices from Naturally Occurring

Biologically Derived Materials” (Attorney Docket No. 265280-71142, DEP-748); Serial No. XX/XXX,XXX entitled “Unitary Surgical Device and Method” (Attorney Docket No. DEP-750); and Serial No. XX/XXX,XXX entitled “Porous Extracellular Matrix Scaffold and Method” (Attorney Docket No. 265280-71146, DEP-747). It is
5 expected that the materials and devices disclosed in those patent applications can be used in the present invention.

Similarly, it is expected that other materials may be combined with the biological lubricant or with the scaffold. For example, bioactive agents, biologically derived agents, cells, biocompatible inorganic material and/or combinations thereof
10 may be mixed with the scaffold material or biological lubricant.

“Bioactive agents” include one or more of the following: chemotactic agents; therapeutic agents (e.g., antibiotics, steroidal and non-steroidal analgesics and anti-inflammatories, anti-rejection agents such as immunosuppressants and anti-cancer drugs); various proteins (e.g., short chain peptides, bone morphogenic proteins,
15 glycoprotein and lipoprotein); cell attachment mediators; biologically active ligands; integrin binding sequence; ligands; various growth and/or differentiation agents (e.g., epidermal growth factor, IGF-I, IGF-II, TGF- β I-III, growth and differentiation factors, vascular endothelial growth factors, fibroblast growth factors, platelet derived growth factors, insulin derived growth factor and transforming growth factors,
20 parathyroid hormone, parathyroid hormone related peptide, bFGF; TGF β superfamily factors; BMP-2; BMP-4; BMP-6; BMP-12; sonic hedgehog; GDF5; GDF6; GDF8; PDGF); small molecules that affect the upregulation of specific growth factors; tenascin-C; hyaluronic acid; chondroitin sulfate; fibronectin; decorin; thromboelastin; thrombin-derived peptides; heparin-binding domains; heparin; heparan sulfate; DNA
25 fragments; and DNA plasmids. If other such substances have therapeutic value in the orthopaedic field, it is anticipated that at least some of these substances will have use in the present invention, and such substances should be included in the meaning of “bioactive agent” and “bioactive agents” unless expressly limited otherwise.

“Biologically derived agents” include one or more of the following:
30 bone (autograft, allograft, and xenograft) and derivatives of bone; cartilage (autograft, allograft, and xenograft), including, for example, meniscal tissue, and derivatives; ligament (autograft, allograft, and xenograft) and derivatives; derivatives of intestinal tissue (autograft, allograft, and xenograft), including for example submucosa;

-16-

derivatives of stomach tissue (autograft, allograft, and xenograft), including for example submucosa; derivatives of bladder tissue (autograft, allograft, and xenograft), including for example submucosa; derivatives of alimentary tissue (autograft, allograft, and xenograft), including for example submucosa; derivatives of respiratory tissue (autograft, allograft, and xenograft), including for example submucosa; derivatives of genital tissue (autograft, allograft, and xenograft), including for example submucosa; derivatives of liver tissue (autograft, allograft, and xenograft), including for example liver basement membrane; derivatives of skin tissue; platelet rich plasma (PRP), platelet poor plasma, bone marrow aspirate, demineralized bone matrix, insulin derived growth factor, whole blood, fibrin and blood clot. Purified ECM and other collagen sources are also intended to be included within “biologically derived agents.” If other such substances have therapeutic value in the orthopaedic field, it is anticipated that at least some of these substances will have use in the present invention, and such substances should be included in the meaning of “biologically derived agent” and “biologically derived agents” unless expressly limited otherwise.

“Biologically derived agents” also include bioremodelable collagenous tissue matrices. The expressions “bioremodelable collagenous tissue matrix” and “naturally occurring bioremodelable collagenous tissue matrix” include matrices derived from native tissue selected from the group consisting of skin, artery, vein, pericardium, heart valve, dura mater, ligament, bone, cartilage, bladder, liver, stomach, fascia and intestine, tendon, whatever the source. Although “naturally occurring bioremodelable collagenous tissue matrix” is intended to refer to matrix material that has been cleaned, processed, sterilized, and optionally cross-linked, it is not within the definition of a naturally occurring bioremodelable collagenous tissue matrix to purify the natural fibers and reform a matrix material from purified natural fibers. The term “bioremodelable collagenous tissue matrices” includes “extracellular matrices” within its definition.

“Cells” include one or more of the following: chondrocytes; fibrochondrocytes; osteocytes; osteoblasts; osteoclasts; synoviocytes; bone marrow cells; mesenchymal cells; stromal cells; stem cells; embryonic stem cells; precursor cells derived from adipose tissue; peripheral blood progenitor cells; stem cells isolated from adult tissue; genetically transformed cells; a combination of chondrocytes and

other cells; a combination of osteocytes and other cells; a combination of synoviocytes and other cells; a combination of bone marrow cells and other cells; a combination of mesenchymal cells and other cells; a combination of stromal cells and other cells; a combination of stem cells and other cells; a combination of embryonic stem cells and other cells; a combination of precursor cells isolated from adult tissue and other cells; a combination of peripheral blood progenitor cells and other cells; a combination of stem cells isolated from adult tissue and other cells; and a combination of genetically transformed cells and other cells. If other cells are found to have therapeutic value in the orthopaedic field, it is anticipated that at least some of these cells will have use in the present invention, and such cells should be included within the meaning of "cell" and "cells" unless expressly limited otherwise. Illustratively, in one example of embodiments that are to be seeded with living cells such as chondrocytes, a sterilized implant may be subsequently seeded with living cells and packaged in an appropriate medium for the cell type used. For example, a cell culture medium comprising Dulbecco's Modified Eagles Medium (DMEM) can be used with standard additives such as non-essential amino acids, glucose, ascorbic acid, sodium pyruvate, fungicides, antibiotics, etc., in concentrations deemed appropriate for cell type, shipping conditions, etc.

"Biocompatible inorganic materials" include materials such as hydroxyapatite, all calcium phosphates, alpha-tricalcium phosphate, beta-tricalcium phosphate, calcium carbonate, barium carbonate, calcium sulfate, barium sulfate, polymorphs of calcium phosphate, sintered and non-sintered ceramic particles, and combinations of such materials. If other such substances have therapeutic value in the orthopaedic field, it is anticipated that at least some of these substances will have use in the present invention, and such substances should be included in the meaning of "biocompatible inorganic material" and "biocompatible inorganic materials" unless expressly limited otherwise.

It is expected that various combinations of bioactive agents, biologically derived agents, cells, biological lubricants, biocompatible inorganic materials, biocompatible polymers can be used with the scaffolds and methods of the present invention.

-18-

It is expected that standard disinfection and sterilization techniques may be used with the products of the present invention.

EXAMPLE 1

5 A defect in goat articular cartilage was repaired with a device as illustrated in Fig. 11. HA was applied post-operatively after repairing the defect with a synthetic scaffold according to Fig. 11. When compared to cartilage defects repaired without HA, the tissue repaired with both the device and HA appeared to be more mature, with a whiter, more hyaline-like appearance. Also, the repaired tissue
10 that is treated with both the device and HA showed evidence of less severe degradative changes than is seen in the non-HA treated animals.

 Although the examples all relate to use of HA, it is expected that other biological lubricants will provide similar benefits. It should be understood that the nature of the biological lubricant and the means of administering the biological
15 lubricant can affect the quality of lubrication provided and can also affect the biological effects observed. For example, although a biological lubricant such as HA can be cross-linked to the matrix and still provide adequate lubrication, some GAG sulfates (e.g., chondroitin sulfate) can be expected to be less effective, or ineffective, as a lubricant if cross-linked or co-lyophilized with the underlying matrix, yet still be
20 used for its biological effects. For some biological lubricants, it will be desirable to provide the biological lubricant in a fluidized form to maximize lubrication. In addition, different materials identified as falling within the definition of biological lubricants can be expected to have different efficacies as lubricants and different biological efficacies. Of the identified biological lubricants, those sharing properties
25 (e.g., viscosity) similar to those of HA may provide greater clinical benefit as lubricants. Of the identified biological lubricants, those decreasing the coefficient of friction between the implant and healthy cartilage, compared to the case without the lubricant, are expected to be beneficial, and particularly those biological lubricants providing a reduced coefficient of friction for an extended period time. Other of the
30 identified biological lubricants may provide greater clinical benefit as biologic agents. It should also be understood that materials identified as biological lubricants and the means of administering the material may be combined in various ways to take

-19-

advantage of the properties of each and to maximize the clinical benefits of administering the various materials.

Although the invention has been described in detail with reference to certain preferred embodiments, variations and modifications exist within the scope
5 and spirit of the invention as described and defined in the following claims.

-20-

CLAIMS:

1. A method for the repair of a cartilagenous tissue defect comprising the steps of
5 implanting a scaffold into the defect, and
 administering a biological lubricant to the defect, wherein the biological lubricant is not cross-linked to the scaffold.
2. The method of claim 1, wherein the implanting step and administering step take place during a single surgical procedure.
- 10 3. The method of claim 2, further comprising an additional post-operative administration of biological lubricant to the defect.
4. The method of claim 1, wherein the biological lubricant comprises a GAG.
5. The method of claim 1, wherein the biological lubricant is
15 selected from the group consisting of: hyaluronic acid; a salt of hyaluronic acid; sodium hyaluronate; dermatan sulfate; heparan sulfate; chondroitin sulfate; keratan sulfate; synovial fluid; a component of synovial fluid; vitronectin; and rooster comb hyaluronate.
6. The method of claim 1, further comprising the step of
20 closing an incision site created to implant the scaffold, and
 wherein the administering step is subsequent to the closing step, and the biological lubricant is administered to the defect via injection in the area of the defect.
7. The method of claim 1, wherein the defect is in the knee and
25 the biological lubricant is administered by injection into the knee joint cavity.
8. The method of claim 1, wherein the biological lubricant is administered to the defect by saturating the scaffold with a biological lubricant solution prior to implantation.
9. The method of claim 1, wherein the scaffold is provided pre
30 saturated with biological lubricant.
10. The method of claim 2, further comprising the step of

-21-

providing a series of additional biological lubricant injections to the area of the defect subsequent to the surgical procedure.

11. The method of claim 10, wherein the defect is in the knee joint and the injections are into the knee joint cavity.

5 12. The method of claim 10, wherein the series of additional biological lubricant injections comprises a first additional biological lubricant injection two weeks subsequent to the surgical procedure and a second additional biological lubricant injection four weeks subsequent to the surgical procedure.

10 13. The method of claim 1, wherein the defect is in a meniscus and implanting step is a surgical procedure comprising performing a partial menisectomy to create a space, placing the scaffold into the space, and fixing the scaffold to surrounding meniscal tissue.

15 14. The method of claim 1, wherein the scaffold comprises a synthetic polymer.

15 15. The method of claim 14, wherein the synthetic polymer has a structure selected from the group consisting of woven, knitted, warped knitted, nonwoven, braided, and foamed.

20 16. The method of claim 14, wherein the synthetic polymer is selected from the group consisting of PLA, PGA, PCL, PDO, TMC, PVA, copolymers thereof, and blends thereof.

17. The method of claim 14, wherein the scaffold further comprises an extracellular matrix.

25 18. The method of claim 1, wherein the device further comprises at least one additional substance selected from the group consisting of: a bioactive agent; a biologically derived substance; cells; and a biocompatible inorganic material.

30 19. A method for the repair of a cartilaginous tissue defect comprising the steps of implanting a scaffold comprising a synthetic polymer into the defect, and administering a GAG to the defect, wherein the GAG is not crosslinked to the scaffold.

-22-

20. The method of claim 19, wherein the GAG is not crosslinked to the scaffold.
21. The method of claim 20, wherein the implanting step and administering step take place during a single surgical procedure.
- 5 22. The method of claim 21, further comprising an additional post-operative administration of a biological lubricant to the defect.
23. The method of claim 22, wherein the biological lubricant of the additional post-operative administration comprises the GAG.
24. The method of claim 23, wherein the GAG comprises HA.
- 10 25. The method of claim 20, further comprising the step of closing an incision site created to implant the scaffold, and wherein the administering step is subsequent to the closing step, and the GAG is administered to the defect via injection in the area of the defect.
26. The method of claim 25, wherein the defect is in the knee and the injection is into the knee joint cavity.
- 15 27. The method of claim 20, wherein the biological lubricant is administered to the defect by saturating the scaffold with a biological lubricant solution prior to implantation.
28. The method of claim 20, wherein the scaffold is provided pre-saturated with biological lubricant.
- 20 29. The method of claim 19, further comprising a series of post-operative biological lubricant injections wherein the series of post-operative biological lubricant injections comprises a first post-operative lubricant injection two weeks subsequent to the surgical procedure and a second post-operative biological lubricant injection four weeks subsequent to the surgical procedure.
- 25 30. The method of claim 19, wherein the defect is in a meniscus and implanting step comprises
- performing a partial menisectomy to create a space,
placing the scaffold into the space, and
- 30 fixing the scaffold to surrounding meniscal tissue.
31. The method of claim 19, wherein the GAG is HA.
32. The method of claim 19, wherein the GAG is crosslinked to the scaffold.

-23-

33. The method of claim 19, wherein the scaffold consists essentially of the synthetic polymer.
34. A cartilage repair device comprising a synthetic polymer scaffold and a biological lubricant applied to the polymer.
- 5 35. The cartilage repair device of claim 34, wherein the biological lubricant comprises a solution.
36. The cartilage repair device of claim 34, wherein the biological lubricant solution comprises a GAG.
37. The cartilage repair device of claim 36, wherein the biological
10 lubricant solution comprises HA.
38. The cartilage repair device of claim 37, wherein the HA is a high molecular weight sodium hyaluronate.
39. The cartilage repair device of claim 34, wherein the device further comprises a biologic component.
- 15 40. The cartilage repair device of claim 39, wherein the biologic component comprises an ECM.
41. The cartilage repair device of claim 40, wherein the ECM matrix comprises tissue derived from a source selected from the group consisting of: vertebrate small intestine submucosa; vertebrate liver basement membrane; vertebrate
20 bladder submucosa; vertebrate stomach submucosa; vertebrate alimentary tissue; vertebrate respiratory tissue; and vertebrate genital tissue.
42. The cartilage repair device of claim 34, further comprising an additional material selected from the group consisting of: a bioactive agent; a biologically derived substance; and cells.
- 25 43. The cartilage repair device of claim 34 wherein the synthetic polymer scaffold comprises a plug configured to be positioned in an opening formed in damaged cartilage.
44. The cartilage repair device of claim 43 wherein the plug is secured to an anchor.
- 30 45. The cartilage repair device of claim 43 further comprising an anchor configured to secure the plug in the opening.
46. A method of making a cartilage repair device comprising: providing a scaffold;

-24-

providing a biological lubricant in liquid form; and
wetting the scaffold with the liquid biological lubricant to form a wet
implant.

5 47. The method of claim 46, further comprising packaging the wet
implant and terminally sterilizing the packaged wet implant.

48. The method of claim 46, further comprising drying the wet
implant, packaging the dry implant and terminally sterilizing the packaged dry
implant.

10 49. The method of claim 46, wherein the scaffold comprises a
synthetic polymer.

50. The method of claim 49, wherein the scaffold further comprises
a naturally occurring extracellular matrix.

15 51. The method of claim 46, further comprising incorporating into
the wet implant a material selected from the group consisting of: a bioactive agent; a
biologically derived substance; and cells.

1/5

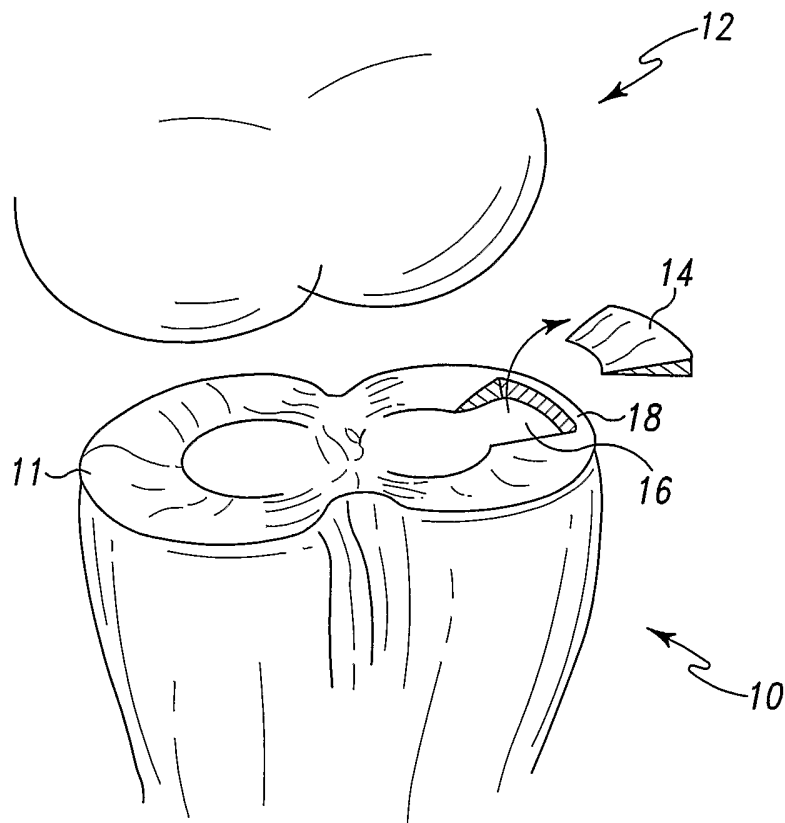

Fig. 1

2/5

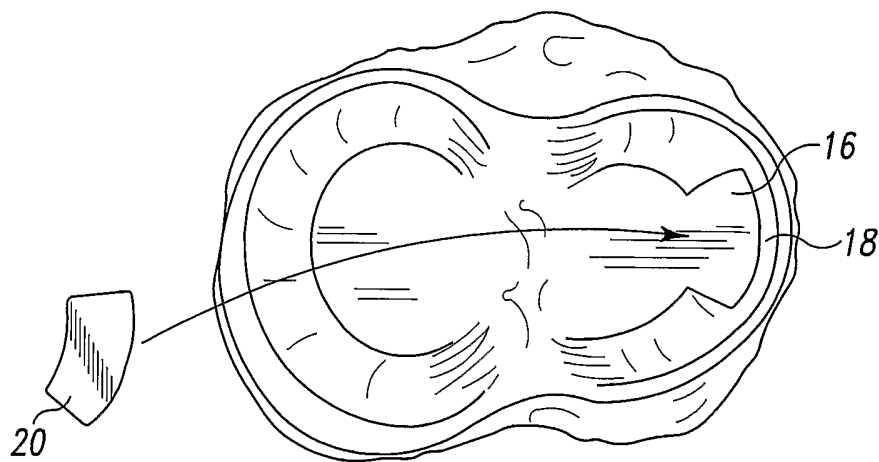

Fig. 2

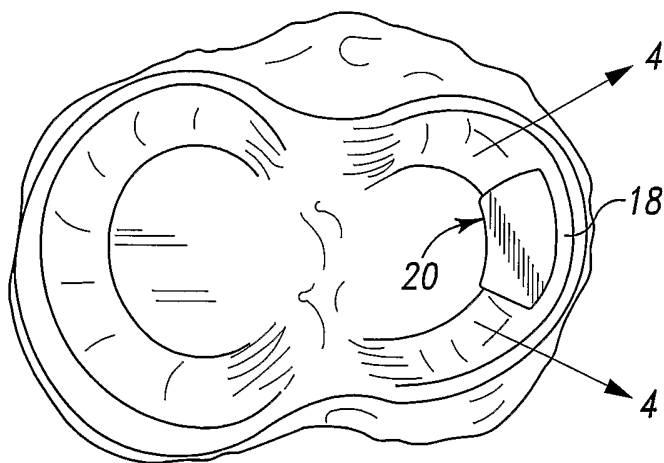

Fig. 3

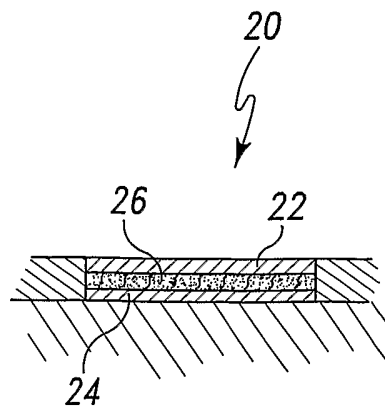

Fig. 4

3/5

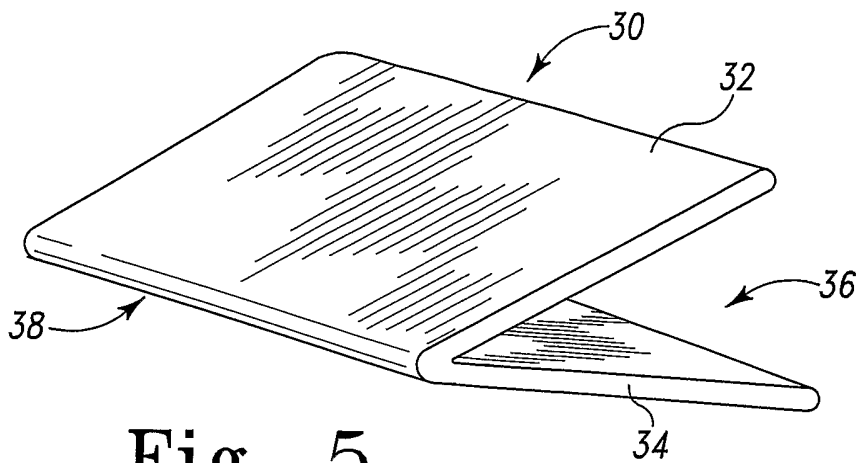

Fig. 5

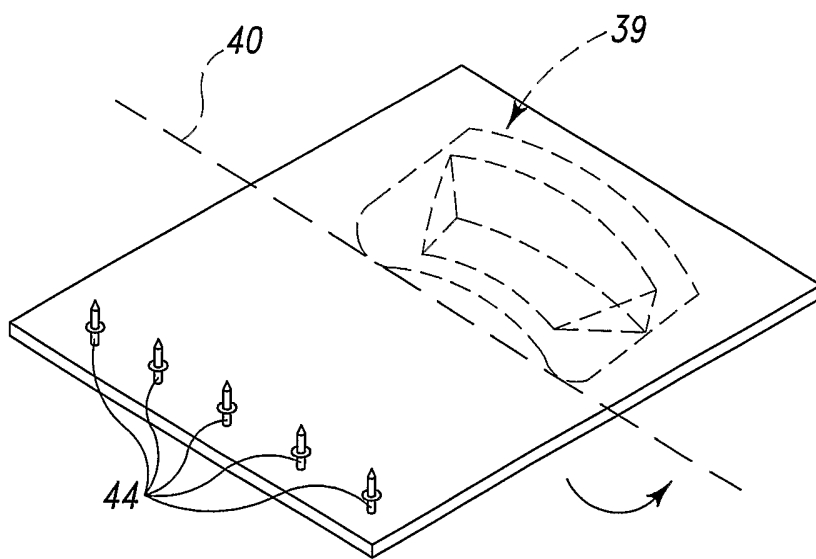

Fig. 6

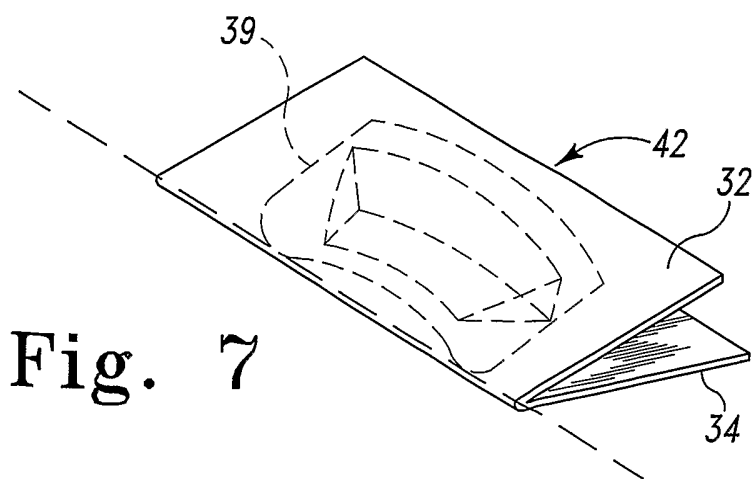

Fig. 7

4/5

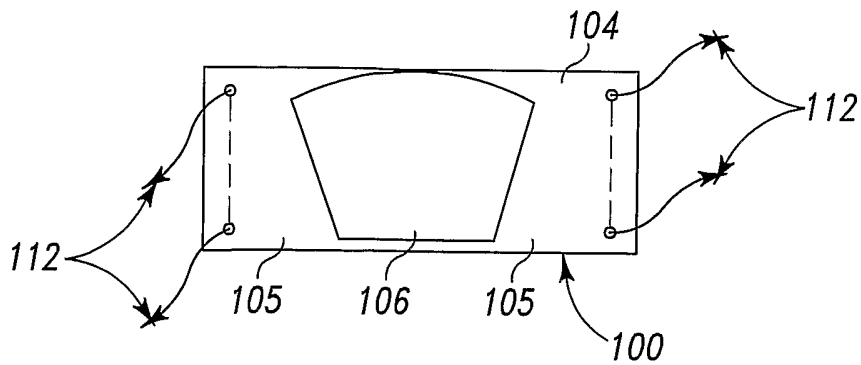

Fig. 8

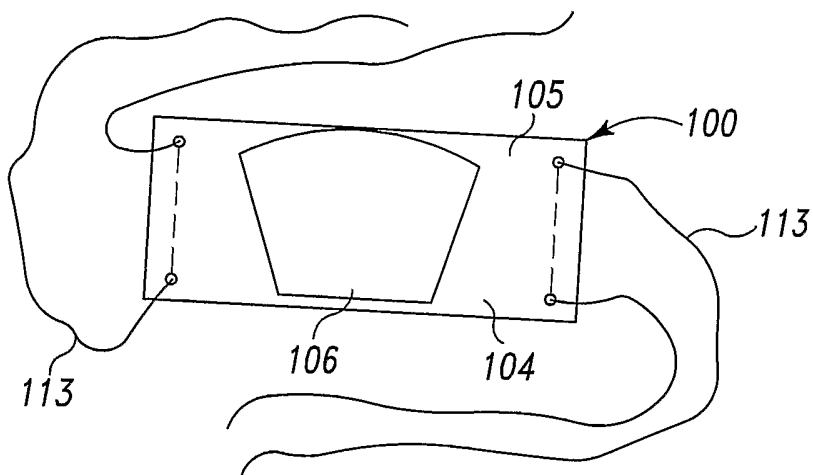

Fig. 9

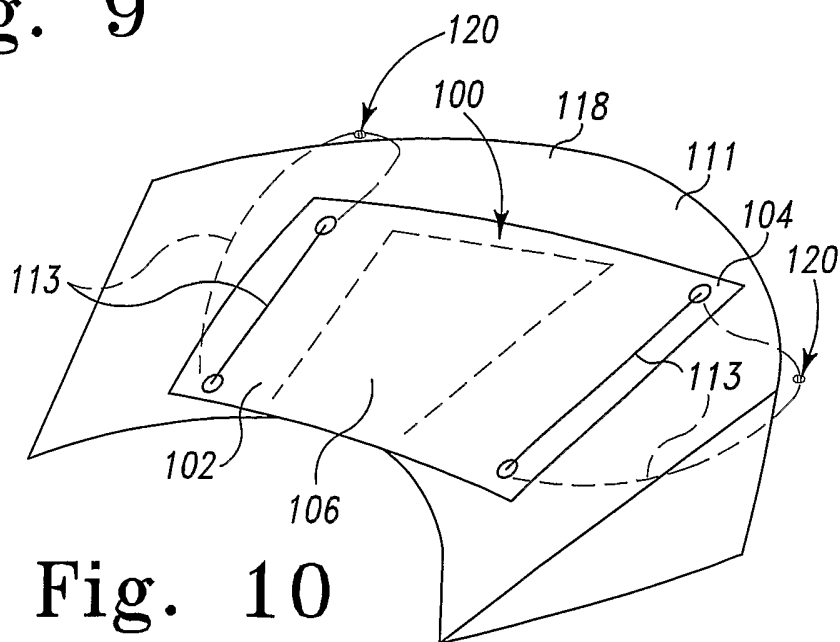

Fig. 10

5/5

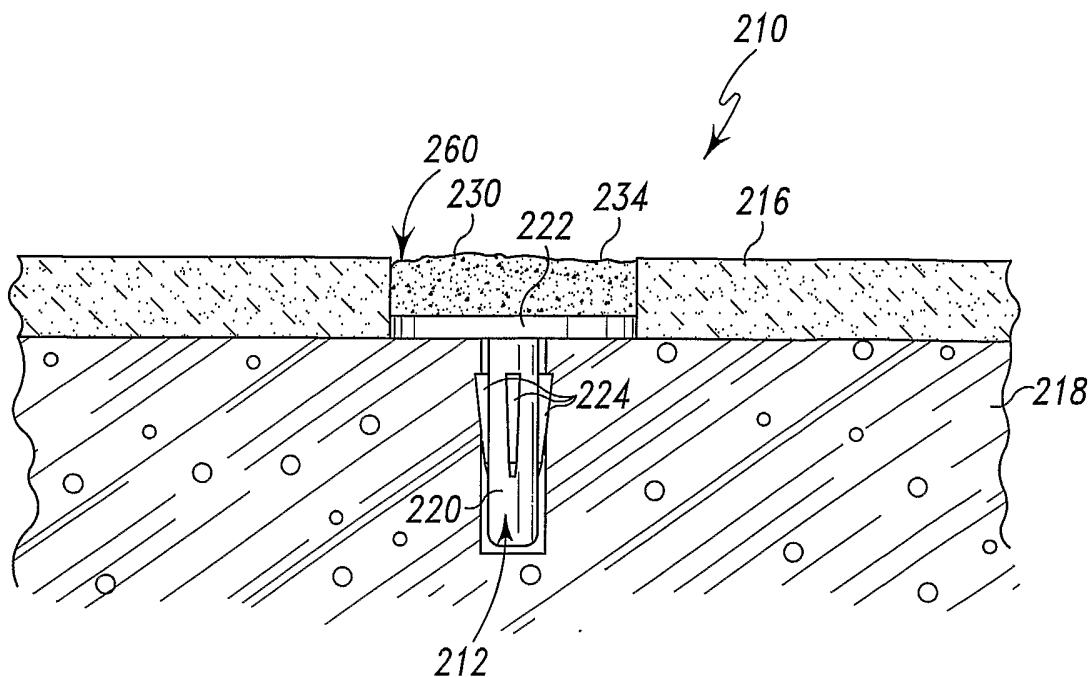

Fig. 11

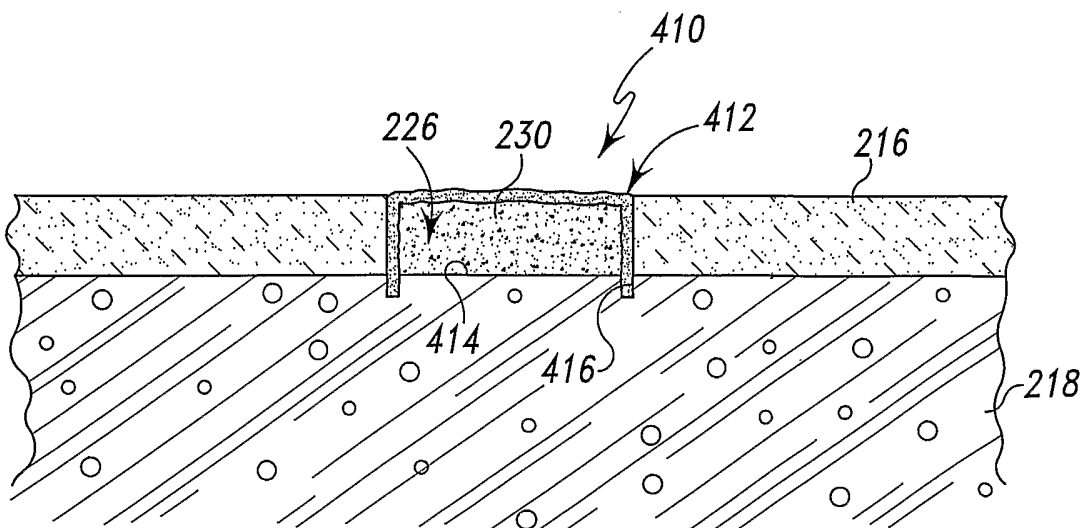

Fig. 12