

M. P. SCHENCK.  
ELECTRIC GOVERNOR.

No. 522,920.

Patented July 10, 1894.

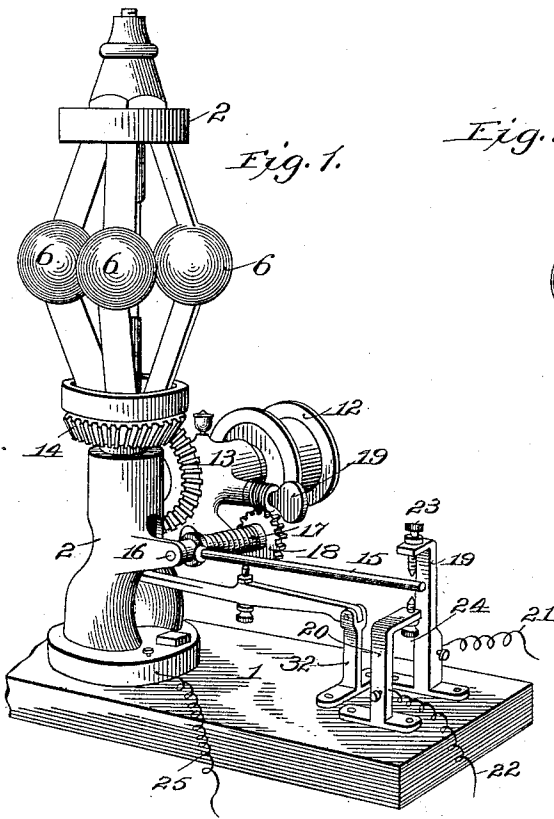

Fig. 1.

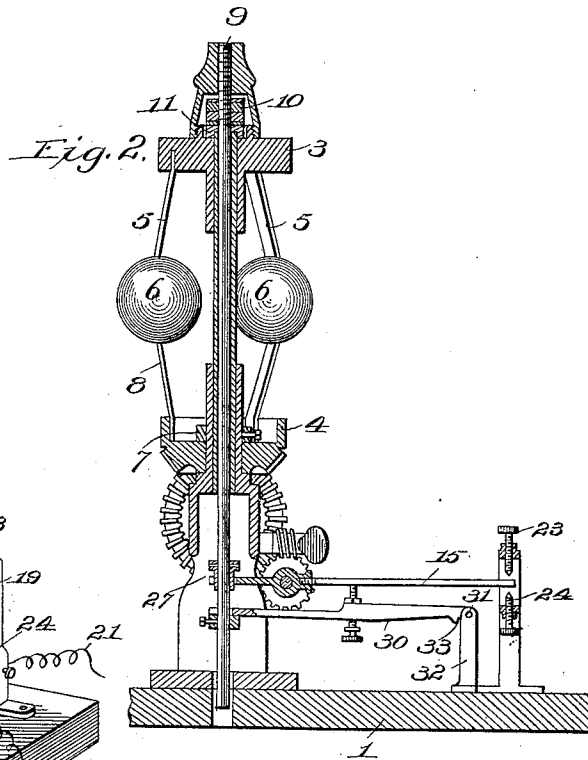

Fig. 2.

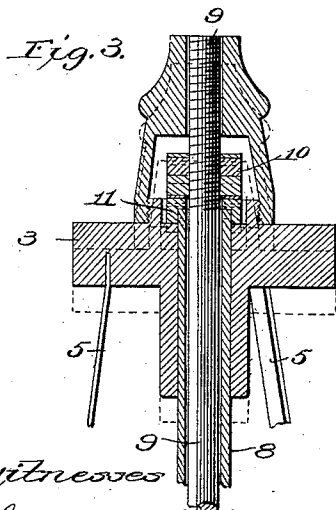

Fig. 3.

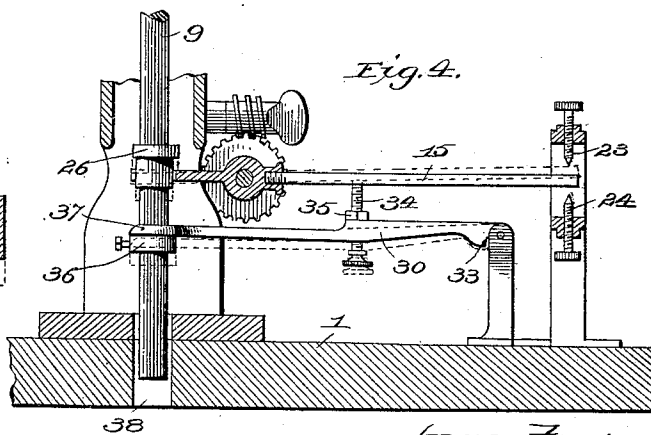

Fig. 4.

witnesses  
 Harry D. Robur.  
 Geo. E. Cruise.

Inventor:  
 Marcus P. Schenck.  
 By Knight Bros.  
 Atty's.

(No Model.)

2 Sheets—Sheet 2.

M. P. SCHENCK.  
ELECTRIC GOVERNOR.

No. 522,920.

Patented July 10, 1894.

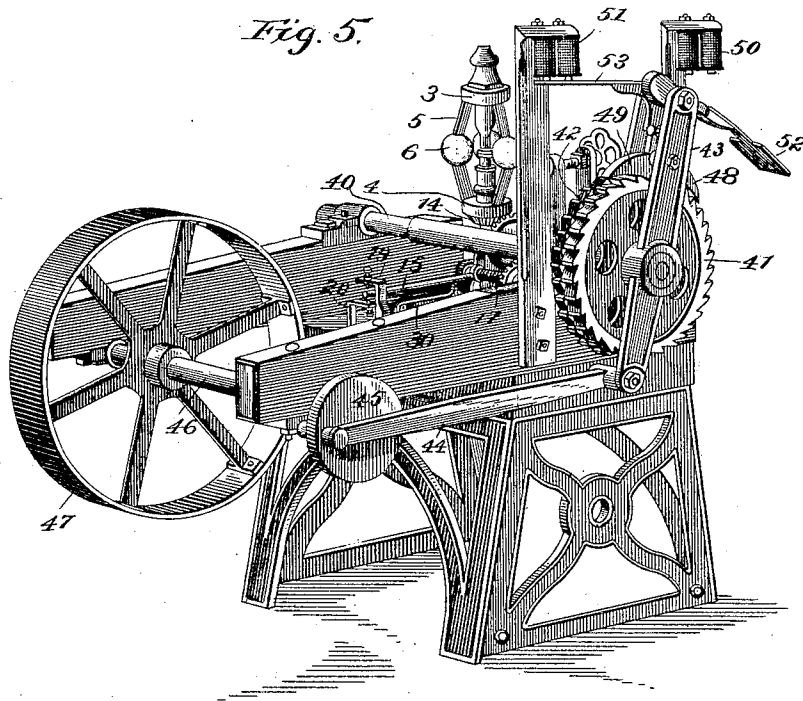

Witnesses:

*Chas. F. Miller.*  
*Geo. E. Conner.*

Inventor:  
*Marcus P. Schenck.*

By *Knights Bros.*  
Attys.

# UNITED STATES PATENT OFFICE.

MARCUS P. SCHENCK, OF SPRINGFIELD, MASSACHUSETTS.

## ELECTRIC GOVERNOR.

SPECIFICATION forming part of Letters Patent No. 522,920, dated July 10, 1894.

Application filed November 21, 1893. Serial No. 491,568. (No model.)

*To all whom it may concern:*

Be it known that I, MARCUS P. SCHENCK, a citizen of the United States, residing at Springfield, in the county of Hampden and State of Massachusetts, have invented a certain new and useful Improvement in Electric Governors, of which the following specification, taken in connection with the accompanying drawings, is a full, clear, and exact description.

My invention relates to that class of electro-mechanical governors for water wheels or other motors in which a constantly operating mechanism is thrown into gear with the valve or gate of a water wheel or other motor by suitable electro-magnetic devices which are under the control of a centrifugal governor, whereby the increase or diminution of power is automatically effected to meet the varying demands upon the motor and keep it at a practically constant speed. A prominent example of this class of governors is found in Patent No. 380,817, granted April 10, 1888, to Frank E. Prichard. The device set forth in this patent comprises essentially a rotatable shaft which is geared to and adapted to control the valve or gate which regulates the supply of water or other fluid to the motor, a ratchet wheel keyed to said shaft, an oscillating bar which is geared to the main power shaft of the motor and kept constantly oscillating thereby, a pair of pawls carried by the oscillating bar above the ratchet wheel and adapted to engage therewith, and an electro-magnetic controlling device under the influence of the variations in speed of a centrifugal governor which is also geared to the main power shaft of the motor, whereby the pawls on the oscillating bar are independently thrown into engagement with the ratchet wheel for effecting the increase or diminution in the supply of water or other fluid to the motor. The electro-mechanical device which is under the influence of the centrifugal governor, and which controls the action of the pawls, comprises an independent electro-magnet for throwing each pawl into gear with the ratchet wheel, two open electric circuits embracing the independent magnets, a vertically moving rod embraced by the centrifugal governor, and a pivoted arm engaged by the vertical rod of the governor and constituting a part of both of the electric circuits

and adapted to complete either circuit under the influence of the governor.

In the above-described governor, the pivoted arm is supported in neutral position when the governor is running at normal speed, so as not to affect the valve-operating mechanism; but, should the speed of the governor slow up, the pivoted arm will be moved to complete the circuit of the magnet which throws the pawl into engagement for increasing the supply of water or other fluid, or, should the speed become too great, the arm is moved in the other direction for completing the circuit of the other magnet and diminishing the supply.

The speed of a motor can be kept practically the same with the above-described governor under ordinary circumstances, but there is one very serious objection to its use. If, while the motor is running at full speed, the band which communicates motion from the main shaft to the governor pulley, should break or slip off the pulley, it will be seen that the main motor will continue to run, while the governor will gradually diminish its speed and stop and thereby move the pivoted arm into position to complete the circuit for increasing the supply of water. The constantly increasing supply of water to the motor then causes it to constantly increase in speed until it is liable to run beyond control, break the machinery and result in other serious trouble. In view of this danger, it is very desirable that the water should be either entirely shut off or that the supply should remain the same, in case of an accident to the belt which runs the centrifugal governor; and it is the object of my present invention to provide means for accomplishing this desired result.

To this end my invention consists essentially of a suitable attachment combined with an electric governor substantially as above described, which can be adjusted to retain the normal supply of water, or shut the water off entirely when the belt of the governor breaks or drops off the pulley.

In order that my invention may be fully understood I will first describe the same with reference to the accompanying drawings and afterward particularly point out the novelty in the annexed claims.

Figure 1 is a front perspective view of an electric governor embodying my improvements and representing the governor running at normal speed. Fig. 2 is a sectional elevation of the same representing the governor at a standstill. Figs. 3 and 4 are enlarged detail sectional elevations of parts of Fig. 2. Fig. 5 is a front perspective view of the electrically-controlled valve-operating mechanism.

Mounted upon a suitable base 1 is the centrifugal governor, which comprises the standard 2, the upper and lower rings 3, 4, which are connected by the springs 5 which support the balls 6, a collar 7 for confining the lower ring 4 on its bearing, a tube 8 which passes through the rings 3 and 4 for supporting them in the same vertical line, and a vertically movable adjustable rod 9, which moves with the upper movable ring 3 of the governor and actuates the electric controlling device. The rod 9 is screw-threaded at its upper end for the reception of the nuts 10, whereby its position can be adjusted. Embracing the upper end of the tube 8 and surrounding the rod 9 is a flanged washer 11, which serves to support the rod centrally in the tube 8.

12 is the pulley on the horizontal shaft of the governor, which has keyed to its opposite end the gear wheel 13 which meshes with the integral gear wheel 14 of the lower ring 4. The pulley 12 receives its motion from the main power shaft of the motor, and thereby operates the governor.

15 is an oscillatory arm, pivotally supported upon a rod at 16 which is journaled in suitable brackets extending from the standard 2 of the governor, and provided with a torsional spring 17, one end of which engages the arm 15, while the other end engages the gear wheel 18 which is keyed to the rod 16.

19 is a hand-operated worm, which is journaled in a suitable bearing on the governor standard 2, and geared with the gear wheel 18, so that the tension of the spring 17 can be regulated to exert any desired pressure on the arm 15. The purpose of this will appear presently.

19 and 20 are binding posts to which the circuit wires 21 and 22 are respectively attached.

23 and 24 are contact screws adjustably supported in said binding posts 19 and 20 respectively.

25 is a circuit wire having electrical connection with the standard 2 of the governor, and from it to the arm 15. Thus it will be seen that the complete circuit can be made through wire 25, standard 2, arm 15 and binding post 19 and wire 21 or binding post 20 and wire 22, by simply moving the arm 15 into contact with either of the contact screws 23 or 24. The wires 21 and 22 connect respectively with the magnets controlling the turning on and shutting off of the water, while the wire 25 connects with both of said magnets and a

suitable battery; the magnets controlling the valve-operating device, in a manner substantially as above described.

26 is a collar fixed to the rod 9 at such a point as to engage the end 27 of the arm 15, when the speed of the governor is normal, and thereby hold the arm 15 between the contact points 23 and 24 in opposition to the tendency of the spring 17 which forces the outer end of the arm downward. If the speed becomes above normal, the rod 9 will move farther down, and cause the end of the rod 15 to come in contact with the contact screw 23 and thereby close the circuit which excites the magnet having control over the pawl which effects the shutting off of some of the water.

30 is a lever pivotally supported at 31 to a post 32, and formed with a shoulder 33 which engages the post and prevents the arm from falling lower than the horizontal position.

34 is an adjustable screw having a clamping nut 35. The lever 30 is supported directly under the oscillatory arm so that the screw 34 can come in contact with said arm for the purpose presently to be explained.

36 is an adjustable collar secured to the rod 9 and adapted to come in contact with the bifurcated end 37 of the lever 30. The rod 9 passes freely through an opening 38 in the base 1.

40 is a rotatable shaft geared to and adapted to control the valve or gate which regulates the supply of water or other fluid to the motor. The manner of gearing the shaft and gate is not shown.

41 and 42 are oppositely arranged ratchet wheels keyed to the shaft 40.

43 is an oscillating bar loosely mounted on the end of the shaft 40, and kept constantly oscillating by means of a pitman 44, and eccentric 45 which gears it to the constantly rotating shaft 46 provided with the pulley 47. The pulley 47 is geared to the main power shaft by a suitable belt.

48 and 49 are a pair of pawls carried by the oscillating bar 43 above the oppositely arranged ratchet wheels 41 and 42 and adapted to engage therewith.

50 and 51 are electro-magnets. 52 and 53 are armature levers properly connected to the pawls 48 and 49 respectively so as to control their positions. When either of the electro-magnets 50 and 51 is energized by an electric current, the corresponding armature 52 or 53 is attracted and held by the magnet and the pawl 48 or 49 thereby held into engagement with the ratchet wheel 41 or 42 so that the oscillation of the bar 43 will impart a rotary motion to the shaft 40 either forward or backward according to which electro-magnet is energized.

The valve-operating mechanism and the arrangement of magnets for controlling the supply of water or other power to the motor may be of any approved construction, but I prefer

to employ a device substantially as described above.

My attachment may be employed in combination with any governor using the centrifugal governor, valve controller, and electric devices.

The operation may be described as follows:—

When the motor and governor are running at normal speed the arm 15 will be supported in neutral position between the contact screws 23 and 24 by reason of the downward pressure of the collar 26 on the end 27 of the arm 15 being evenly balanced against the pressure of the spring 17. This will be clearly understood as it is the common operation of this class of electric governors. While the governor is running at this normal speed, the arm 30 rests in horizontal position, because the rod 9 is in its lowered position and the collar 36 cannot come in contact with the end 37 of said lever. Should the speed of the motor increase from any cause, the downward pressure on the rod 9 will overbalance the pressure of the spring 17 and the rod 15 will be moved in contact with the screw 23 for completing the circuit through the magnet which effects the cutting off of some of the power. If the speed gets below normal, the pressure of the spring 17 will overbalance, and cause the arm 15 to come in contact with the lower screw 24 and increase the supply of power. If, however, the band breaks or otherwise slips off of the pulley 12, so that the governor will come to a standstill, while the motor runs on, the rod 15 will be raised to its uppermost position which will bring the collar 36 in contact with the lever 30 and raise said lever on its pivot until the screw 34 supports the arm 15 against the pressure of spring 17. This will prevent the arm 15 from being forced down against the contact point 24, which would cause the turning on of a greater amount of power. The screw 34 can be adjusted so as to hold the arm 15 in neutral position between the screws 23 and 24, as shown in Figs. 2 and 4 of the drawings, or, if it is desired to have the water completely shut off when the governor band breaks or slips off, the screw 34 can be readily adjusted to a higher position so that the rod 15 will be forced up into contact with the screw 23 as indicated in dotted lines in Fig.

4. This will result in the shutting off of the entire head of water and stopping the motor.

The value of my improved attachment will be clear from the above description.

Having thus described my invention, the following is what I claim as new therein and desire to secure by Letters Patent:

1. In an electric governor, the combination of suitable valve-operating mechanism, electro-magnets controlling said valve-operating mechanism, open circuits including said electro-magnets and having contact points at the points of opening, an oscillatory arm constituting a common part of both circuits and adapted to complete either circuit by coming in contact with the proper contact point, a centrifugal governor having a vertically movable rod, a lever pivotally supported beneath the oscillatory arm and provided with an adjustable screw which is adapted to engage said oscillatory arm, and a collar on the vertically movable rod of the governor which is adapted to engage said pivoted lever, substantially as and for the purposes set forth.

2. In an electric governor, the combination of suitable valve-operating mechanism, electro-magnets controlling said valve-operating mechanism, open circuits including said electro-magnets and having contact points at the points of opening, an oscillatory arm constituting a common part of both circuits and adapted to complete either circuit, a centrifugal governor having a vertically movable rod which moves downward as the governor expands with increased speed and upward as the governor contracts with decreased speed, a collar on said rod adapted to engage the end of the oscillatory arm, a suitable spring adapted to oppose the pressure of the movable rod on the oscillatory arm, a lever pivoted beneath the oscillatory arm and provided with an adjusting screw which is adapted to engage said oscillatory arm, and a collar on said vertically movable rod which is adapted to engage said pivoted lever, substantially as and for the purposes set forth.

MARCUS P. SCHENCK.

Witnesses:

J. G. DUNNING,  
H. O. PEASE.