

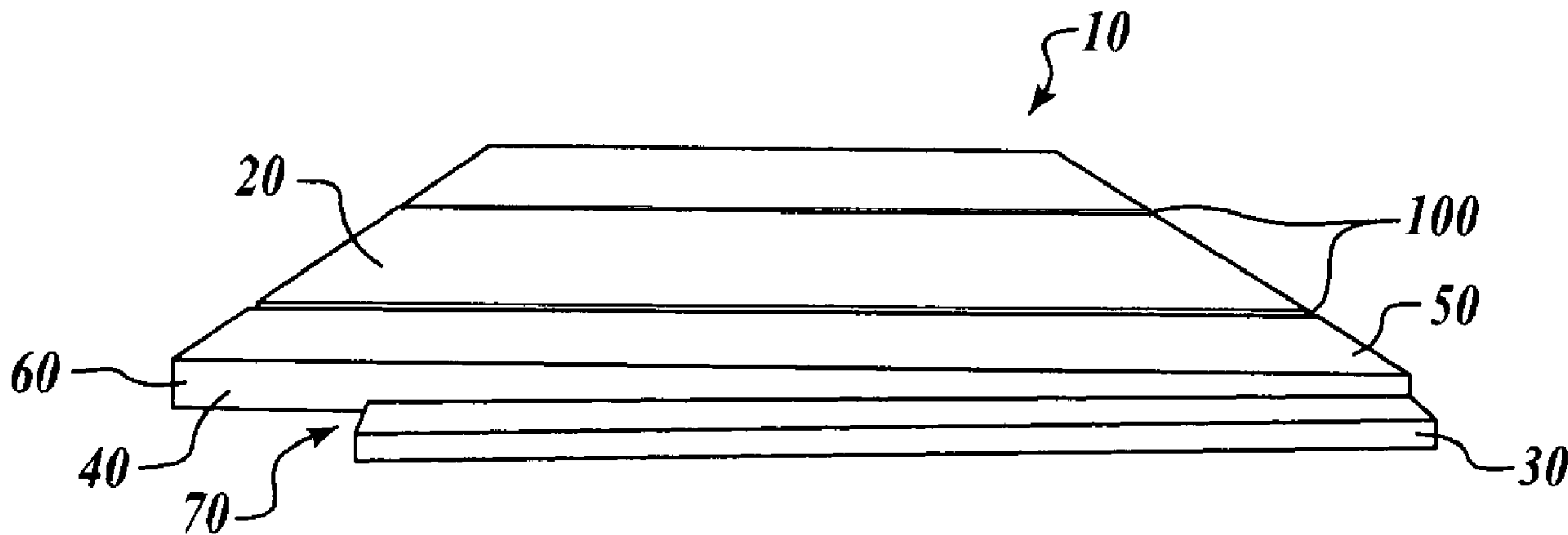

(22) Date de dépôt/Filing Date: 2004/01/22
 (41) Mise à la disp. pub./Open to Public Insp.: 2004/07/23
 (45) Date de délivrance/Issue Date: 2007/09/11
 (30) Priorité/Priority: 2003/01/23 (US60/442,381)

(51) Cl.Int./Int.Cl. *E04D 1/00* (2006.01),
D06N 5/00 (2006.01)
 (72) Inventeurs/Inventors:
GABBARD, BRIAN C., US;
RUTLEDGE, MARK J., US
 (73) Propriétaire/Owner:
SHAKERTOWN 1992, INC., US
 (74) Agent: SMART & BIGGAR

(54) Titre : PANNEAU DE BARDEAUX
 (54) Title: SHINGLE PANEL



(57) **Abrégé/Abstract:**

The shingle panel includes at least one shingle having a first edge, a second edge, a third edge and a fourth edge and at least one backing affixed to the shingle with corresponding first, second, third and fourth edges. The first edge of the backing is substantially aligned with the first edge of the shingle, the second edge of the backing is offset the second edge of the shingle, the third edge of the backing is offset the third edge of the shingle and the fourth edge of the backing is offset the fourth edge of the shingle. The shingle panel may be tapered and include parallel grooves in the shingle and breathing grooves in the backing. The method for manufacturing the shingle panel includes pressing multiple backings on either side of a shingle board and separating the shingle board to produce multiple shingle panels.

SHINGLE PANEL

ABSTRACT OF THE DISCLOSURE

The shingle panel includes at least one shingle having a first edge, a second edge, a third edge and a fourth edge and at least one backing affixed to the shingle with
5 corresponding first, second, third and fourth edges. The first edge of the backing is substantially aligned with the first edge of the shingle, the second edge of the backing is offset the second edge of the shingle, the third edge of the backing is offset the third edge of the shingle and the fourth edge of the backing is offset the fourth edge of the shingle. The shingle panel may be tapered and include parallel grooves in the shingle and
10 breathing grooves in the backing. The method for manufacturing the shingle panel includes pressing multiple backings on either side of a shingle board and separating the shingle board to produce multiple shingle panels.

SHINGLE PANEL

FIELD OF THE INVENTION

This invention relates generally to exterior residential or commercial siding.

5

BACKGROUND OF THE INVENTION

Traditional residential or commercial siding is made of various materials in a variety of shapes and is installed in different ways. A classic siding includes wood-based shingles affixed independently to the side of a building. To improve installation efficiency, multiple shingles can be joined together to form pre-made shingle panels, for example 3-course shingle panels. 3-course shingle panels provide three pre-made rows of shingle panels, allowing an installer to affix multiple shingles in much less time. However, 3-course shingle panels result in significant waste during installation.

10

SUMMARY OF THE INVENTION

Illustrative embodiments of the invention include a shingle panel and method for making the same. The shingle panel includes at least one shingle having a first edge, a second edge, a third edge and a fourth edge, wherein the first edge is substantially opposite the second edge and the third edge is substantially opposite the fourth edge and at least one backing affixed to the shingle, the backing having a first edge, a second edge, a third edge and a fourth edge, wherein the first edge is substantially opposite the second edge and the third edge is substantially opposite the fourth edge. The first edge of the backing is substantially aligned with the first edge of the shingle, the second edge of the backing is offset the second edge of the shingle, the third edge of the backing is offset the third edge of the shingle and the fourth edge of the backing is offset the fourth edge of the shingle.

20

In an alternative embodiment, the shingle of the shingle panel has a thickness and the thickness is tapered from the second edge to the first edge of the shingle.

25

In yet an alternative embodiment, the shingle of the shingle panel has at least one groove extending substantially between the first and second edges of the shingle.

In an alternative embodiment, the backing of the shingle panel includes at least one breathing groove substantially parallel with the third and fourth edges of the backing and extending from the first edge of the backing.

In accordance with another illustrative embodiment of the present invention, there is provided a method for manufacturing a shingle panel. The method includes affixing a first backing to a first side of at least one shingle board having first and second sides, wherein the first side of the shingle board is substantially opposite the second side of the shingle board. A second backing is affixed to the second side of the shingle board. The shingle board affixed between the first and second backings is separated to produce at least one shingle panel. The resultant shingle panel includes at least one shingle associated with the first or second backing, the shingle having a first edge, a second edge, a third edge and a fourth edge, wherein the first edge is substantially opposite the second edge and the third edge is substantially opposite the fourth edge. The associated first or second backing has a first edge, a second edge, a third edge and a fourth edge, wherein the first edge is substantially opposite the second edge and the third edge is substantially opposite the fourth edge. The first edge of the associated first or second backing is substantially aligned with the first edge of the shingle. An offset is produced in the second edge of the associated first or second backing relative to the second edge of the shingle. Additional offsets are produced in at least one of the third and fourth edges of the associated first or second backing.

In an alternative embodiment, the first and second backings are compression pressed to the shingle and allowed to cure for a predetermined period of time.

In yet an alternative embodiment, the shingle has a thickness and the shingle board is separated between the affixed first and second backings at an angle relative to the first and second backings to produce a taper from the second to the first edges of the shingle.

In an alternative embodiment, a breathing groove is produced substantially parallel with the third and fourth edges of the backing in at least one of the first and second backings, and the breathing groove extends from the first edge of the backing.

An illustrative embodiment of the invention is also directed to a method for installing a shingle panel system on a building exterior. A first shingle panel is affixed to the building exterior. The first shingle panel includes at least one shingle having a first edge, a second edge, a third edge and a fourth edge, wherein the first edge is substantially opposite the second edge and the third edge is substantially opposite the fourth edge, a backing affixed to the shingle, the backing having a first edge, a second edge, a third edge and a fourth edge, wherein the first edge is substantially opposite the second edge and the third edge is substantially opposite the fourth edge, and wherein the first edge of the backing is substantially aligned with the first edge of the shingle, the second edge of the backing is offset the second edge of the shingle, the third edge of the backing is offset the third edge of the shingle and the fourth edge of the backing is offset the fourth edge of the shingle.

A second shingle panel is then affixed to the building exterior, the second shingle panel including at least one shingle having a first edge, a second edge, a third edge and a fourth edge, wherein the first edge is substantially opposite the second edge and the third edge is substantially opposite the fourth edge, a backing affixed to the shingle, the backing having a first edge, a second edge, a third edge and a fourth edge, wherein the first edge is substantially opposite the second edge and the third edge is substantially opposite the fourth edge, and wherein the first edge of the backing is substantially aligned with the first edge of the shingle, the second edge of the backing is offset the second edge of the shingle, the third edge of the backing is offset the third edge of the shingle and the fourth edge of the backing is offset the fourth edge of the shingle.

The first shingle panel is affixed to the building exterior along the first edge of the shingle of the first shingle panel. The second shingle panel is affixed to the building exterior along the first edge of the shingle of the second shingle panel. The second shingle panel is positioned relative the first shingle panel such that the first edge of the first and second shingle panels are substantially aligned, the third edge of a second shingle panel substantially abuts the fourth edge of the first shingle panel, and the offset of the third

edge of the second shingle panel interlocks with the offset of the fourth edge of the first shingle panel.

In an alternative embodiment, a third shingle panel is affixed to the building exterior, the third shingle panel including at least one shingle having a first edge, a second edge, a third edge and a fourth edge, wherein the first edge is substantially opposite the second edge and the third edge is substantially opposite the fourth edge, a backing affixed to the shingle, the backing having a first edge, a second edge, a third edge and a fourth edge, wherein the first edge is substantially opposite the second edge and the third edge is substantially opposite the fourth edge, and wherein the first edge of the backing is substantially aligned with the first edge of the shingle, the second edge of the backing is offset the second edge of the shingle, the third edge of the backing is offset the third edge of the shingle and the fourth edge of the backing is offset the fourth edge of the shingle. The third shingle panel is affixed to the building exterior along the first edge of the shingle of the third shingle panel. The third shingle panel is positioned relative the first and second shingle panels such that the second edge of the third shingle panel is aligned with the first edge of the first and second shingle panels such that the second edge of the third shingle panel overlaps the first edge of the first and second shingle panels substantially to the offset of the backing along the second edge of the third shingle panel.

As will be readily appreciated from the foregoing summary, the invention provides a more efficient and cost-effective shingle siding system.

BRIEF DESCRIPTION OF THE DRAWINGS

The preferred and alternative embodiments of the present invention are described in detail below with reference to the following drawings.

FIGURE 1 is an illustration showing a front view of the preferred embodiment of the present invention;

FIGURE 2 is an illustration showing a back view of the preferred embodiment of the present invention;

FIGURE 3 is an illustration showing a side view of the preferred embodiment of the present invention;

FIGURE 4 is an illustration showing multiple shingle panels of the present invention in interlocking fashion;

5 FIGURE 5 is an illustration showing a front view of the preferred embodiment of the present invention including keyway joints;

FIGURE 6 is an illustration showing a back view of the preferred embodiment of the present invention including keyway joints;

10 FIGURE 7 is an illustration showing a perspective side view of the preferred embodiment of the present invention including keyway joints;

FIGURE 8 is an illustration showing a front view of the preferred embodiment of the present invention having an even-butt line together with a tight contemporary joint;

FIGURE 9 is an illustration showing a front view of the preferred embodiment of the present invention having a staggered-butt line together with keyway joints;

15 FIGURE 10 is an illustration showing a perspective side view of a shingle board having a keyway joint notch;

FIGURE 11 is an illustration showing a side view of a shingle panel "sandwich" made in accordance with a preferred embodiment of the present invention prior to being cut into shingle panels; and

20 FIGURE 12 is a flowchart describing a preferred method of manufacturing a shingle panel in accordance with the present invention.

DESCRIPTION OF THE PRESENT INVENTION

As shown with reference to the accompanying drawings and photographs, the present invention is directed to an improved shingle panel and method for creating the same that provides superior benefits over traditional shingle panels. As shown in 25 FIGURES 1-3, and with further reference to FIGURES 5-7, the preferred embodiment of the present shingle panel 10 consists of one or more Western Red cedar shingles 20 held together by a 3-layer plywood backing 30 that is glued or otherwise affixed to each

shingle 20. The backing 30 preferably extends fully from a first edge 50 of the shingle 20 the majority of the way to a second edge 60 of the shingle, thereby providing support for the shingle. The backing 30 preferably terminates short of the second edge 60 of the shingle to provide an alignment line 70. This alignment line is used during installation to
5 vertically align shingle panels. The alignment line also facilitates the overlap of vertically adjacent shingle panels, which in turn allows blind/concealed nailing of the shingle panels.

In the preferred embodiment, the backing 30 is staggered to provide overlocking end joints 80 and corresponding recessed end joints 90. This allowed multiple
10 horizontally adjacent shingle panels to be seamlessly interconnected to provide closely abutting shingles. This also avoids exposed portions of the paper normally applied behind the siding.

In the preferred embodiment, each shingle is cut in a tapered fashion (see FIGURE 3) to provide for a thick butt 40 at the second end 60 of each shingle 20. This
15 provides an enhanced visual depth to the installed shingle panel, creating an improved "shadow-line." Alternatively, each shingle may be cut in a non-tapered fashion (not shown). As illustrated with reference to FIGURES 1, 5 and 7, the shingle panel may be formed using shingles having keyway joints 100. Keyway joints are grooves cut along the surface of the shingle facing away from the house or other exterior to which the shingle
20 panel is applied. The keyway joints provide texturing for the shingle to further enhance the appearance of the building surface, as well as a way to hide or reduce visibility of manufacture seam lines between adjoined shingles. The keyway joints are preferably cut along the vertical line of the shingle, The keyway joint may be cut to a uniform depth along the shingle. Alternatively, the keyway joint may be cut unevenly so as to produce a
25 tapered depth of the joint between edge 50 and edge 60 of the shingle.

In an alternative embodiment, the shingle panel may be formed without a keyway joint, instead having a tight contemporary joint between shingles (FIGURE 8). Likewise, the preferred embodiment is shown using shingles arranged with an even-butt

configuration. Alternatively, the shingle panel may be formed with shingles of varying lengths, creating a staggered-butt line configuration (FIGURE 9).

In an alternative embodiment, as shown with reference to FIGURES 2 and 6, breathing grooves 110 are notched into one or more locations along the backing 30 of the shingle panel, preferably along first edge 50 of one or more shingles 20. When the shingle panels are installed on the exterior of a building, breathing grooves allow moisture and air to flow vertically behind the shingle panels down the side of the building. This facilitates removing moisture from behind the siding, thereby reducing the possibility of accelerated weathering and deterioration of the shingle panels, the siding paper typically applied between the shingle panels and the exterior of the building, and the building surface.

Various material alternatives to cedar for the shingles 20 and plywood for the backing 30 may be used. Examples of alternative shingle material include Eastern White Cedar, Alaskan Yellow Cedar (Cyprus), Southern Yellow Pine, Fir, Spruce, or any other wood or other material suitable for exterior siding. The shingles can be unfinished, primed or finished. Shingles may be finished using any one of a number of finishes, for example, semi-transparent oil stain in colors such as Pasadena Green, Beach Grey, Redwood and Natural Beige. The shingles are preferably finished with an application useful to reduce or eliminate UV rays. Examples of alternative backing material include plywood of different layers, particle board, or any other wood or other material suitable for supporting shingles in the context of exterior siding.

As shown with reference to FIGURES 1 and 4, multiple shingle panels 10 are preferably installed in an interlocking and overlapping fashion. Specifically, in the horizontal direction, the recessed end joint 90 of a shingle panel 10 interlocks with the overlapping end joint 80 of an adjacent shingle panel. In the vertical direction, shingle panels are preferably nailed, stapled or otherwise affixed to the building side by placing nails (or their equivalent) through the shingle and backing near the first edge 50 of the shingles. The alignment line 70 of a subsequently installed vertically adjacent shingle panel is positioned to abut the first edge 50 of the previously installed shingle panel such

that the thick butt 40 at the second end 60 of the shingle overlaps the first end 50 of the previously installed shingle, thereby hiding the affixation nail.

The preferred method of manufacturing shingle panels 10 of the present invention is described with reference to FIGURES 10 and 11 and the flowchart shown in 5 FIGURE 12. A shingle panel 10 is preferably manufactured by sandwiching a finished shingle board 120 between two plywood backings 140. A shingle board is finished through a trimming, sanding and cutting process to produce a shingle board of the desired size and shape. If a keyway joint configuration is desired, each shingle board is notched along one edge. In this example, the shingle board 120 includes a keyway joint notch 130 10 so that the finished shingle panel 10 will include a keyway joint 100.

The preferred method of manufacturing a shingle panel is more fully described with reference to FIGURE 12, At block 200, a plurality of finished shingle boards are placed adjacent to each other. At blocks 202 and 204, glue or other bonding material, preferable PVA (poly vinyl acetate), is placed along the side 150 of the two plywood 15 backing pieces facing the shingle board 120. A full gluing process is preferably used rather than a beading or combination beading and staple process. In the preferred embodiment, at blocks 206 and 208, the configuration is compression pressed together for twenty minutes and allowed to cure 24 hours at 55 degrees.

After the combination of shingle boards and two backing pieces is cured, one of 20 several additional steps may occur, in varying order depending on manufacturing preference. At decision block 210, a determination is made whether one or more overlocking end joints 80 or corresponding recessed end joints 90 are desired. If overlocking end joints or recessed end joints are desired, the logic proceeds to block 212, where desired overlocking end joints 80 or corresponding recessed end joints 90 are cut 25 into the shingle panel 10, preferably using a router. If overlocking end joints or recessed end joints are not desired, the logic proceeds from decision block 210 to decision block 214.

At decision block 214, a determination is made whether breathing grooves 110 are desired. If breathing grooves are desired, the logic proceeds to block 216, where breathing grooves are cut into the backings 140. If breathing grooves are not desired, the logic proceeds from decision block 214 to decision block 218.

5 At decision block 218, a determination is made whether tapered shingles are desired. If tapered shingles are desired, the logic proceeds to block 220, where the combination of shingle boards and two backing pieces is cut into two separate panels along the direction of arrow 160 of FIGURE 11 at an angle to produce two separate panels having tapered shingles. This is preferably accomplished using a band saw. If
10 tapered shingles are not desired, the logic proceeds from decision block 218 to block 222. At block 222, the combination of shingle boards and two backing pieces is cut into two separate panels along the direction of arrow 160 of FIGURE 11 along an even line, with no angel, to produce two separate shingle panels that are not tapered.

The shingle panels may be sized to predetermined lengths at various stages during
15 the manufacturing process by cutting the shingle panels, preferably using a band saw. While the preferred embodiment of the invention has been illustrated and described, as noted above, many changes can be made without departing from the spirit and scope of the invention. Shingle panels of various widths (having different reveals) and lengths are contemplated. As noted above, various materials may be used for the components without
20 departing from the scope of the invention. Also, while the preferred method of manufacturing the shingle panels has been described, variations of this method may be employed to produce the same or similar results. For example, a different bonding agent may be used, provided it is workable to bond the materials chosen for the shingles and backing. The precise length of compression pressing or curing time and temperature may
25 be varied, particularly if a different bonding agent is used. Different types of saws may be used to make the noted cuts for the shingle panel, and the steps of cutting the edges and other notches in the shingle panel may be performed in different order. For example, the order in which decision blocks 210, 214 and 218 occur may be varied. Accordingly, the

scope of the invention is not limited by the disclosure of the preferred embodiment. Instead, the invention should be determined entirely by reference to the claims that follow.

THE EMBODIMENTS OF THE INVENTION IN WHICH AN EXCLUSIVE PROPERTY OR PRIVILEGE IS CLAIMED ARE DEFINED AS FOLLOWS:

1. A method for manufacturing a shingle panel, comprising:

5

affixing a first backing to a first side of at least one shingle board having first and second sides, wherein the first side of the shingle board is substantially opposite the second side of the shingle board;

10

affixing a second backing to the second side of the shingle board;

15

separating the shingle board between the affixed first and second backings to produce at least one shingle panel comprising at least one shingle associated with the first or second backing, the shingle having a first edge, a second edge, a third edge and a fourth edge, wherein the first edge is substantially opposite the second edge and the third edge is substantially opposite the fourth edge, the associated first or second backing having a first edge, a second edge, a third edge and a fourth edge, wherein the first edge is substantially opposite the second edge and the third edge is substantially opposite the fourth edge, and wherein the first edge of the associated first or second backing is substantially aligned with the first edge of the shingle;

20

producing an offset in the second edge of the first or second backing relative to the second edge of the shingle; and

25

producing an offset in at least one of the third and fourth edges of the first or second backing.

30

2. The method of claim 1, wherein the distance between the first and second edges of at least one of the first and second backings is less than the distance between the first and second edges of the shingle.

3. The method of claim 1, wherein the distance between the third and fourth edges of at least one of the first and second backings is less than the distance between the third and fourth edges of the shingle.
- 5 4. The method of claim 1, wherein the first and second backings are affixed to the shingle by glue.
5. The method of claim 4, wherein the first and second backings are compression pressed to the shingle.
- 10 6. The method of claim 5, wherein the first and second backings compression pressed to the shingle are allowed to cure for a predetermined period of time.
7. The method of claim 1, wherein the shingle has a thickness, and further comprising, if a tapered shingle panel is desired, separating the shingle board between the affixed
15 first and second backings at an angle relative to the first and second backings.
8. The method of claim 1, comprising if a breathing groove is desired, producing at least one breathing groove substantially parallel with the third and fourth edges of the
20 backing in at least one of the first and second backings.
9. The method of claim 8, wherein the at least one breathing groove extends from the first edge of the backing.
- 25 10. The method of claim 1, wherein producing an offset in at least one of the third and fourth edges of the associated first or second backing comprises:

producing an offset in the third edge of the first backing relative to the third edge of the shingle; and

30 producing an offset in the fourth edge of the first backing relative to the fourth edge of the shingle.

1/6

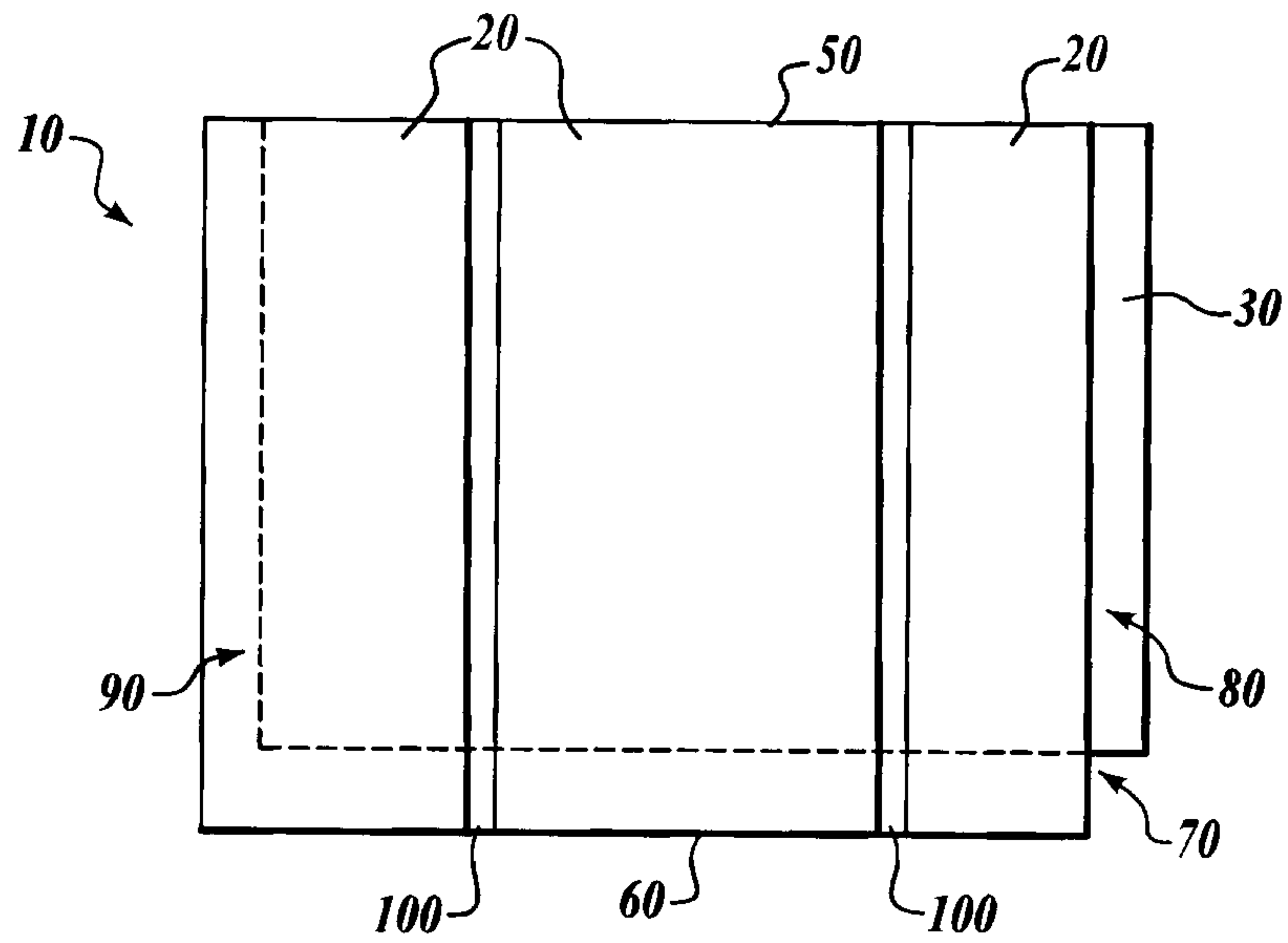

Fig. 1

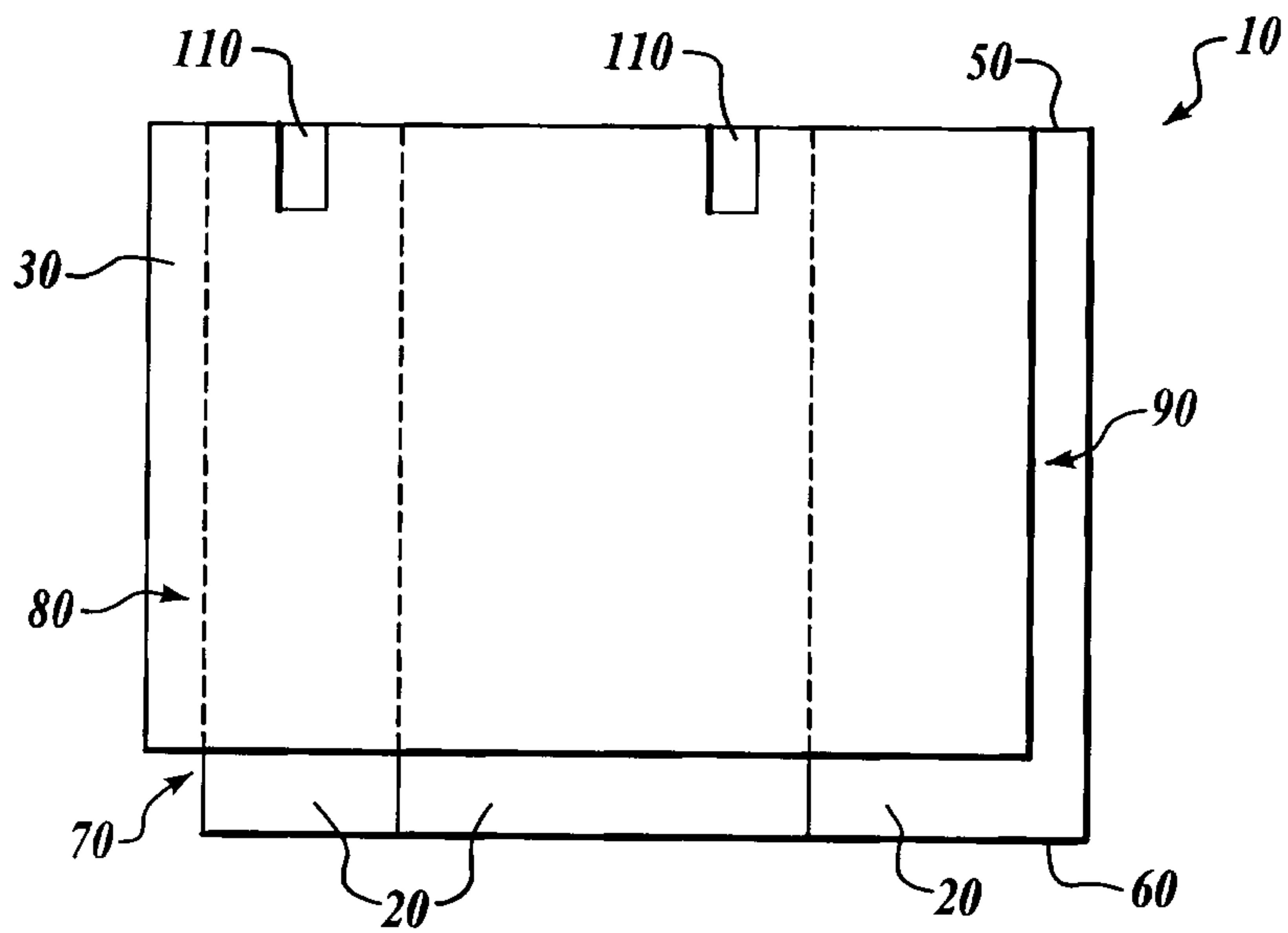

Fig. 2

2/6

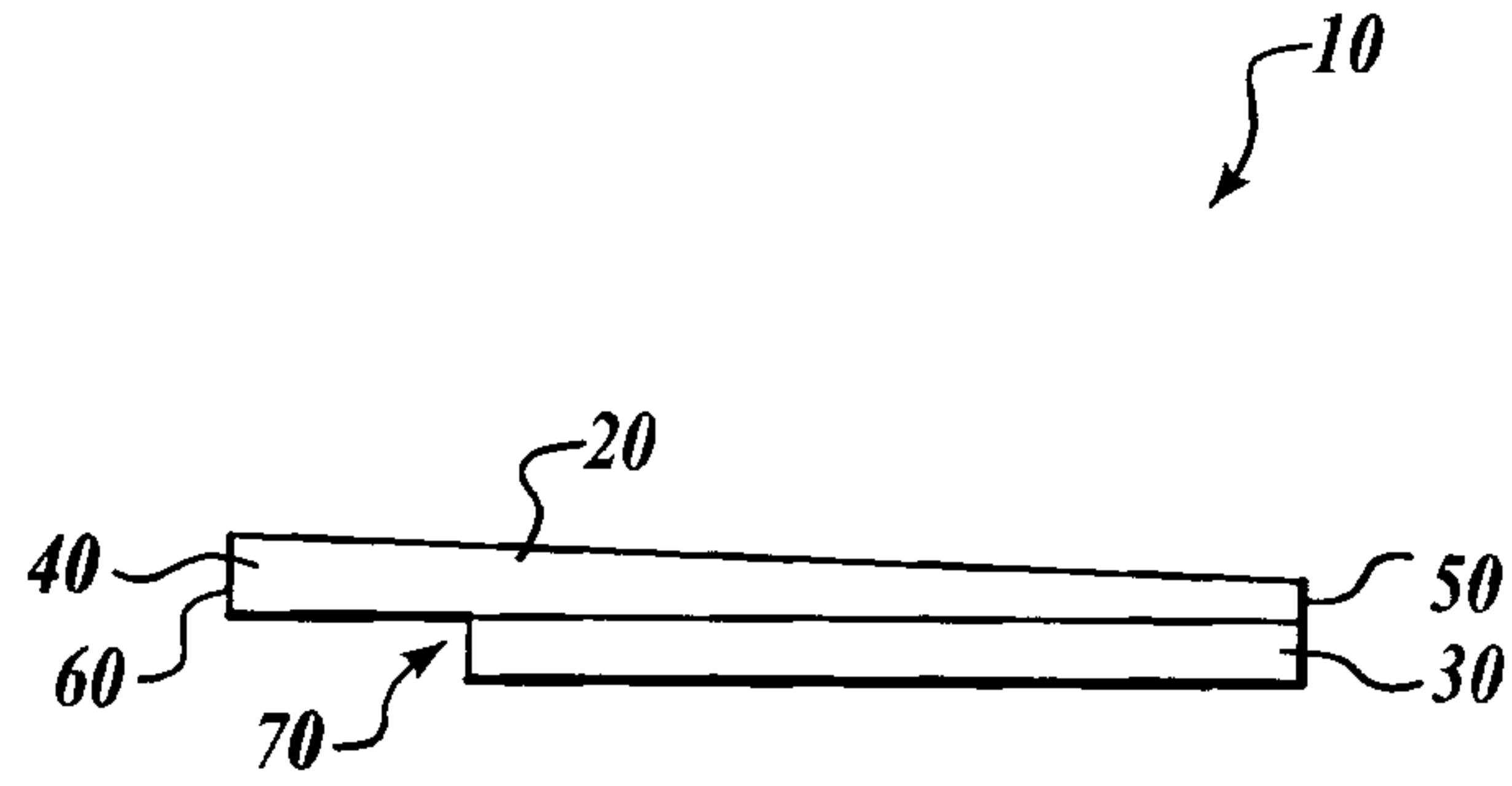

Fig. 3

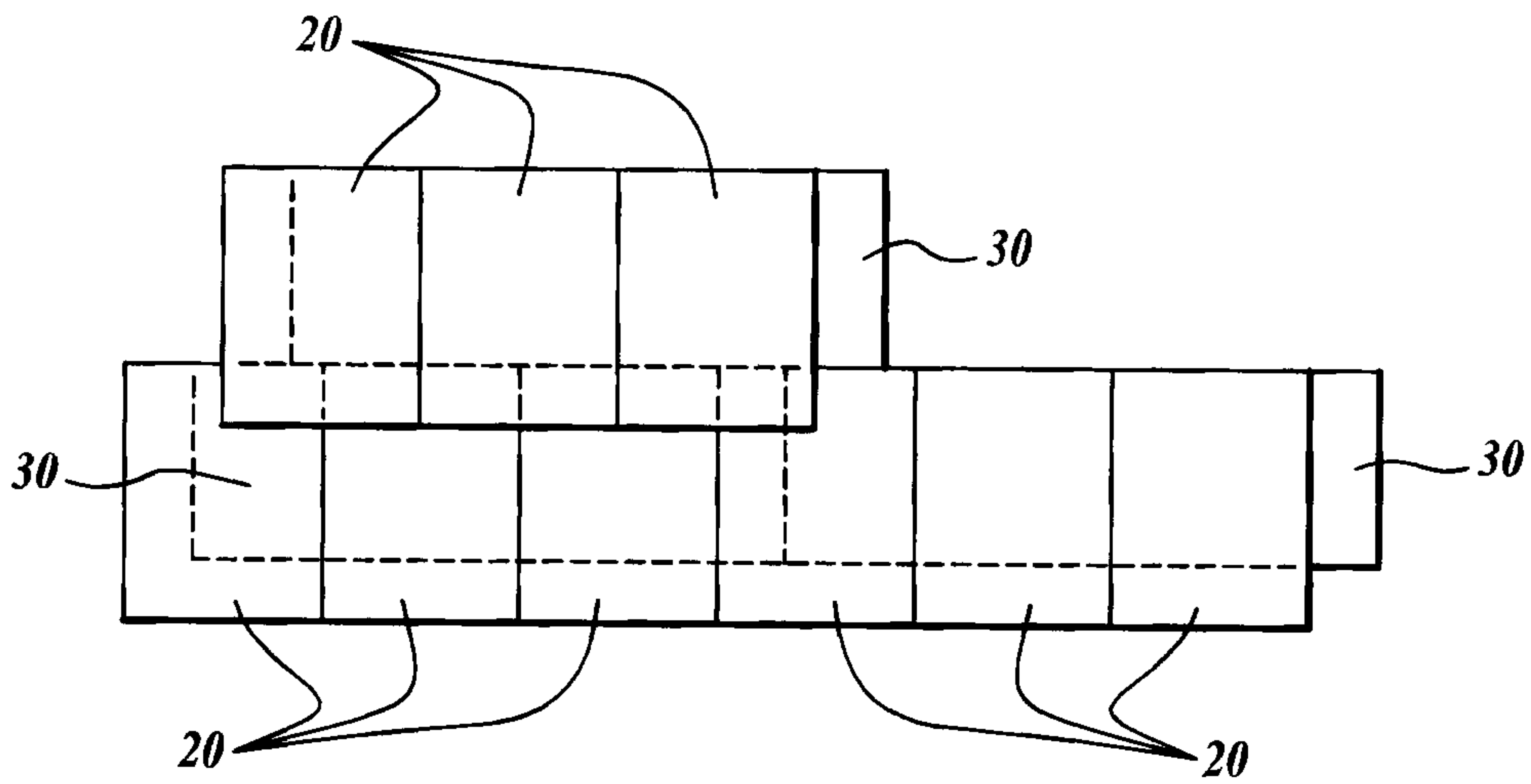

Fig. 4

3/6

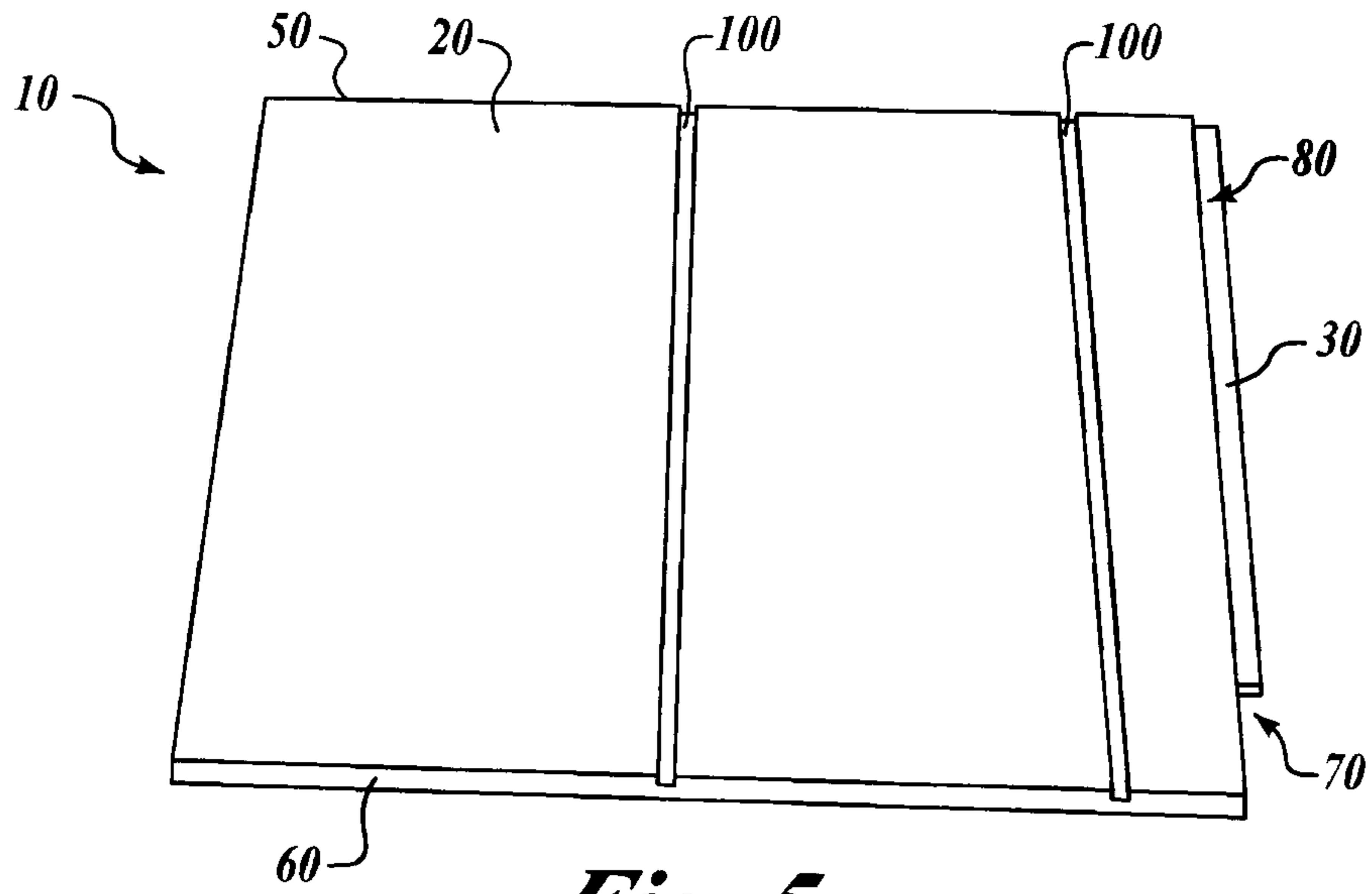

Fig. 5

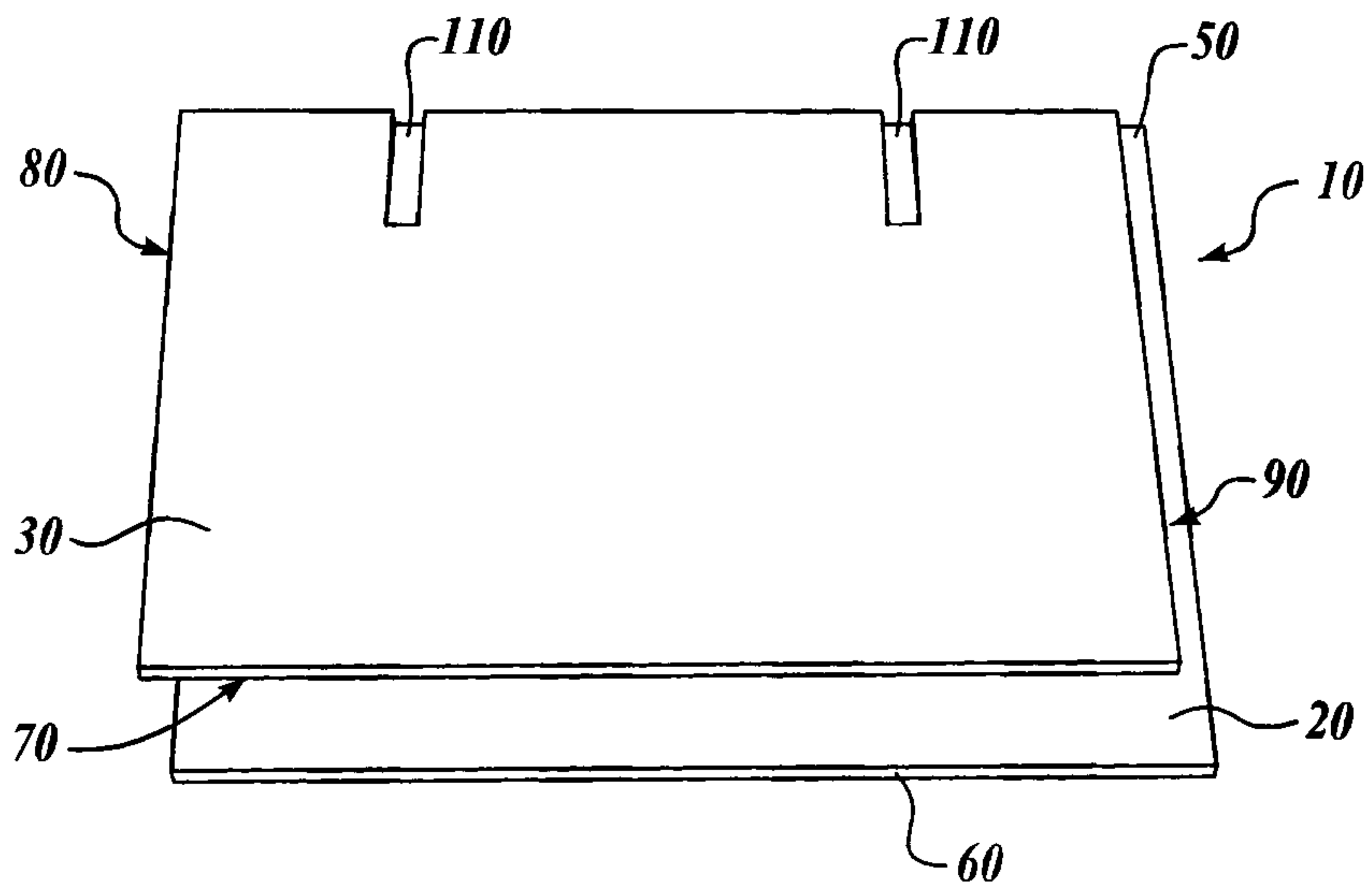

Fig. 6

4/6

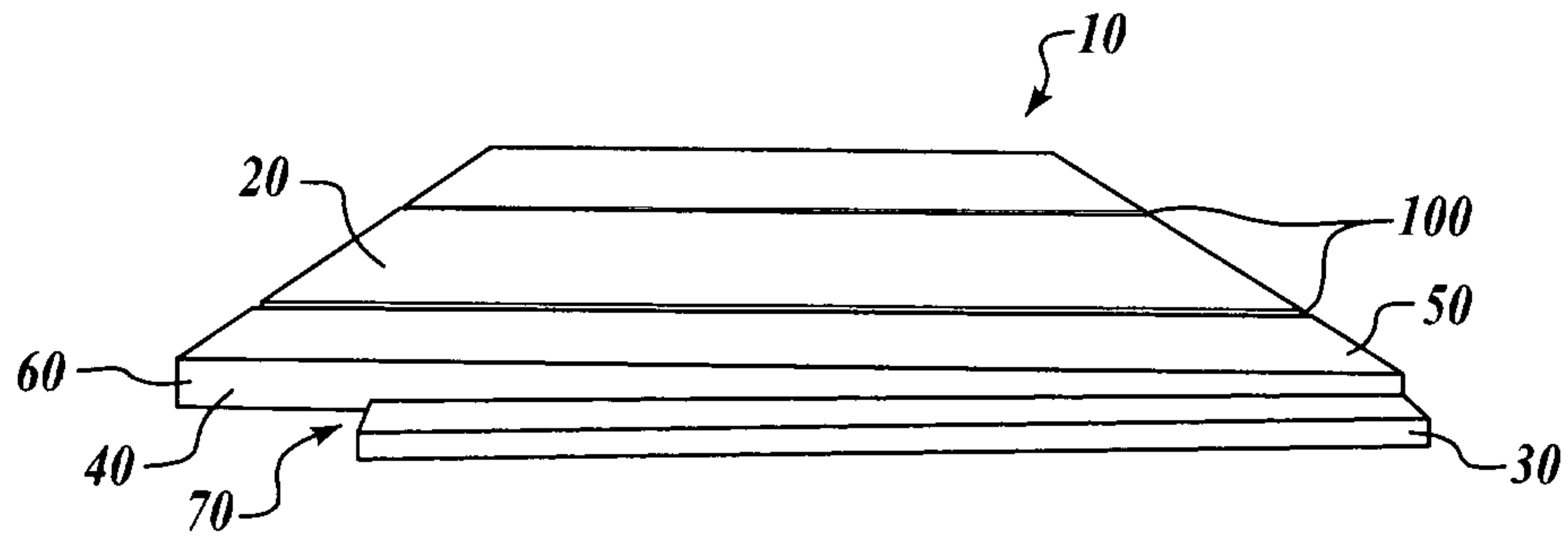

Fig. 7

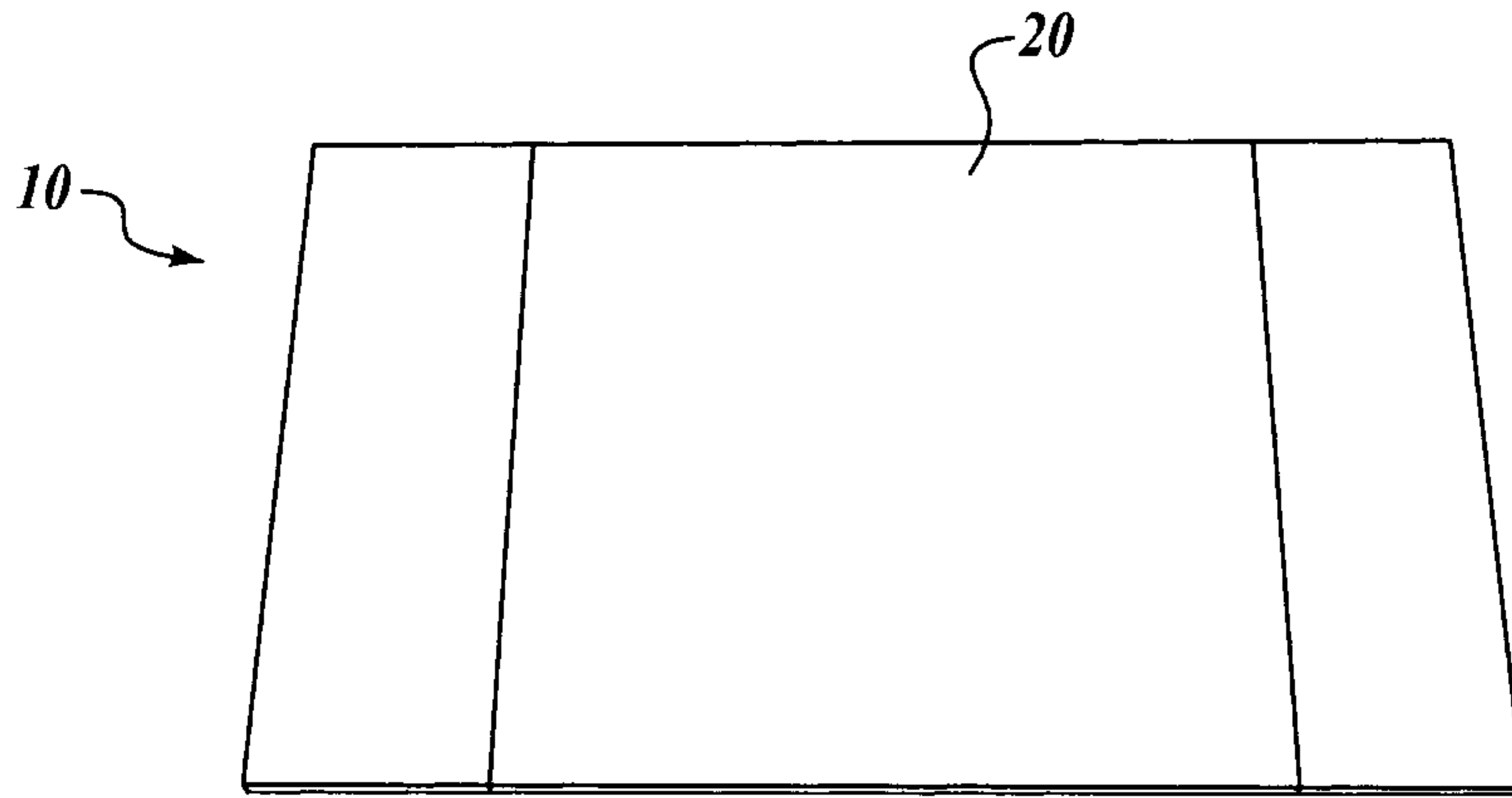

Fig. 8

5/6

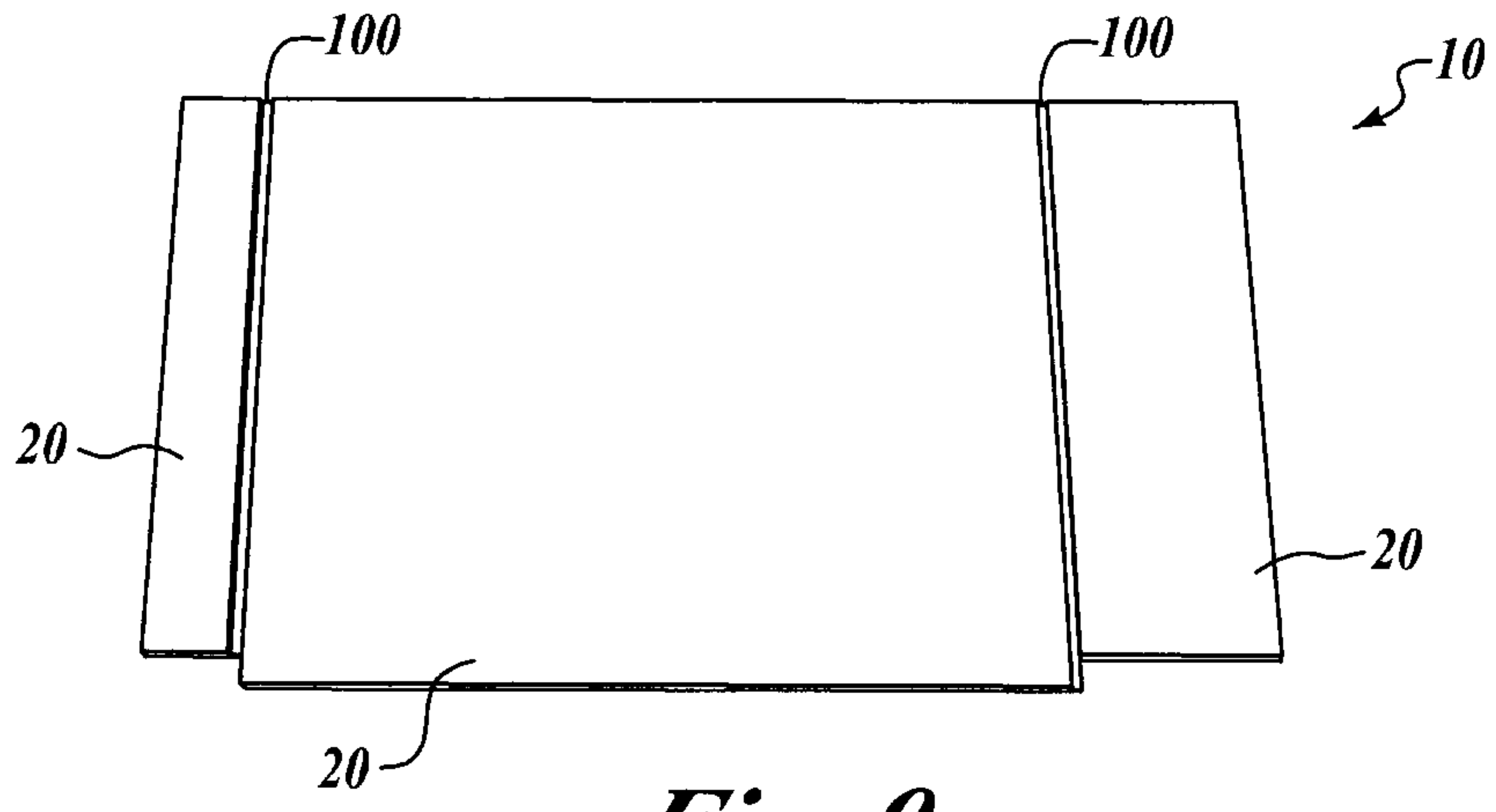

Fig. 9

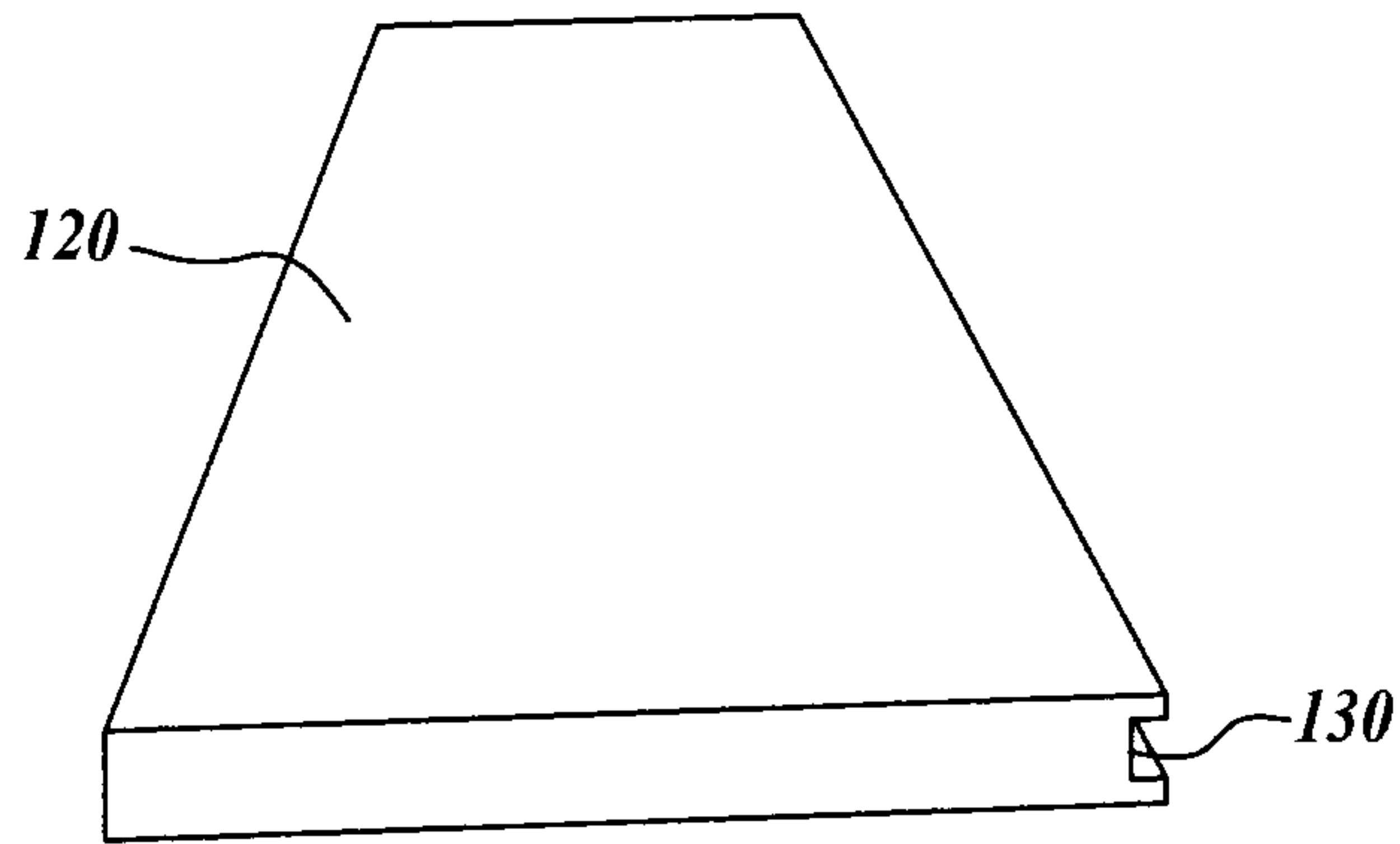

Fig. 10

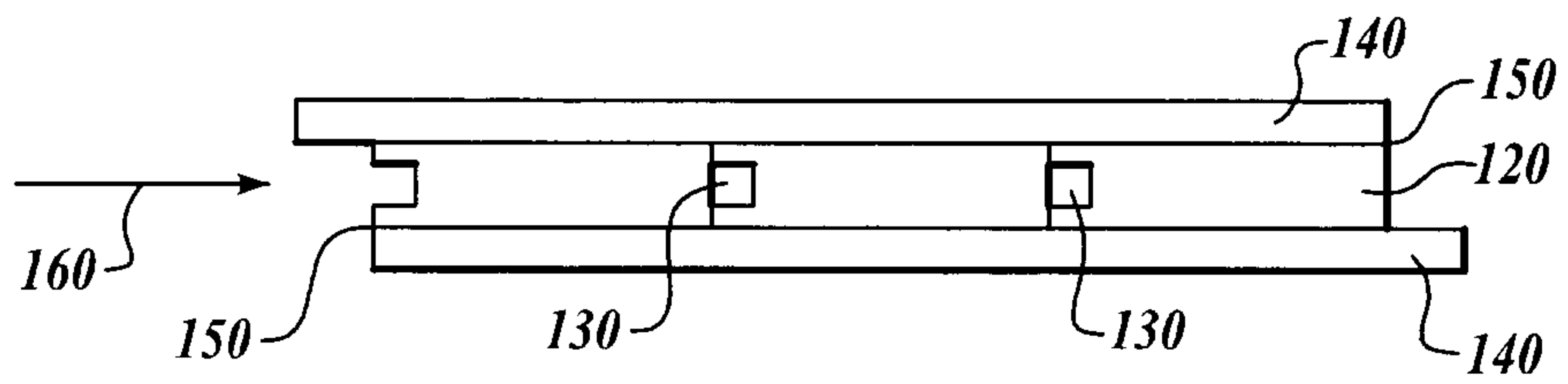
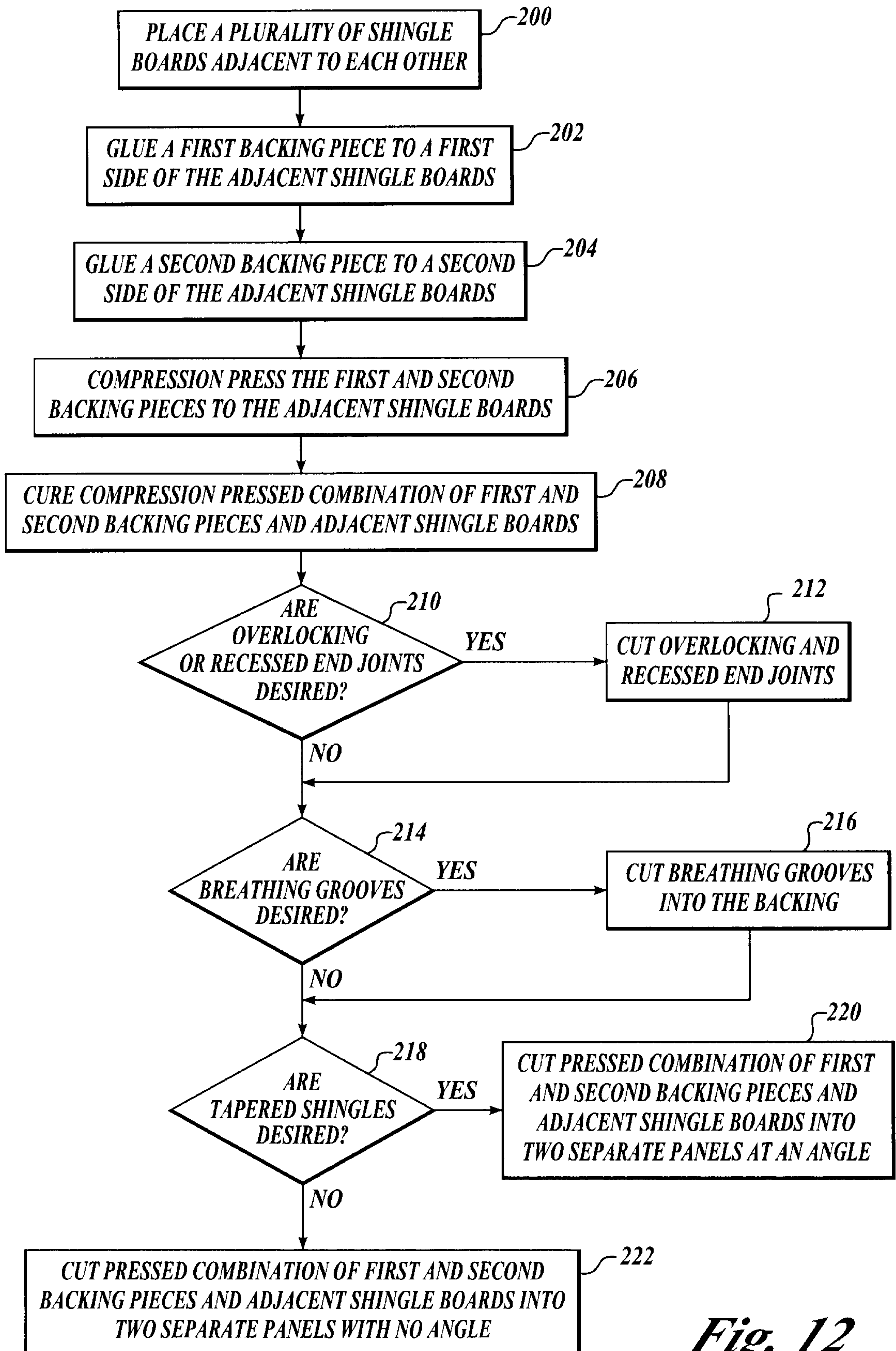

Fig. 11

6/6

*Fig. 12*

